

1. DESCRIPTION

These four-bit magnitude comparators perform comparison of straight binary and straight BCD(8-4-2-1) codes. Three fully decoded decisions about two 4-bit word (A,B) are made and externally available at three outputs. These devices are fully expandable to any number of bits without external gates. Words of greater length may be compared by connecting comparators in cascade. The $A > B$, $A < B$, and $A = B$ outputs of a stage handling less-significant bits are connected to the corresponding $A > B$, $A < B$, and $A = B$ inputs of the next stage handling more-significant bits. The stage handling the least-significant bits must have a high-level voltage applied to the $A = B$ input. The cascading paths of the 74LS85 are implemented with only a two-gate-level delay to reduce overall comparison times for long words. An alternate method of cascading which further reduces the comparison time is shown in the typical application data.

2. PIN CONFIGURATIONS

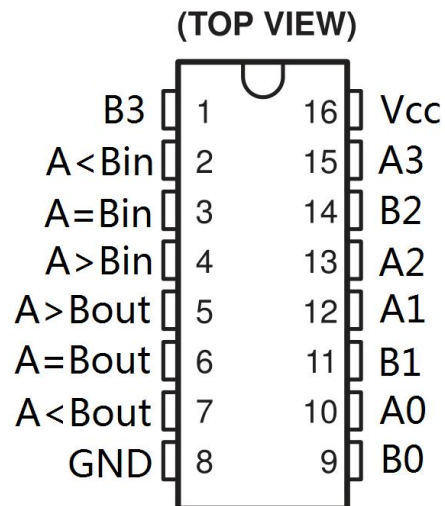

3. LOGIC DIAGRAMS

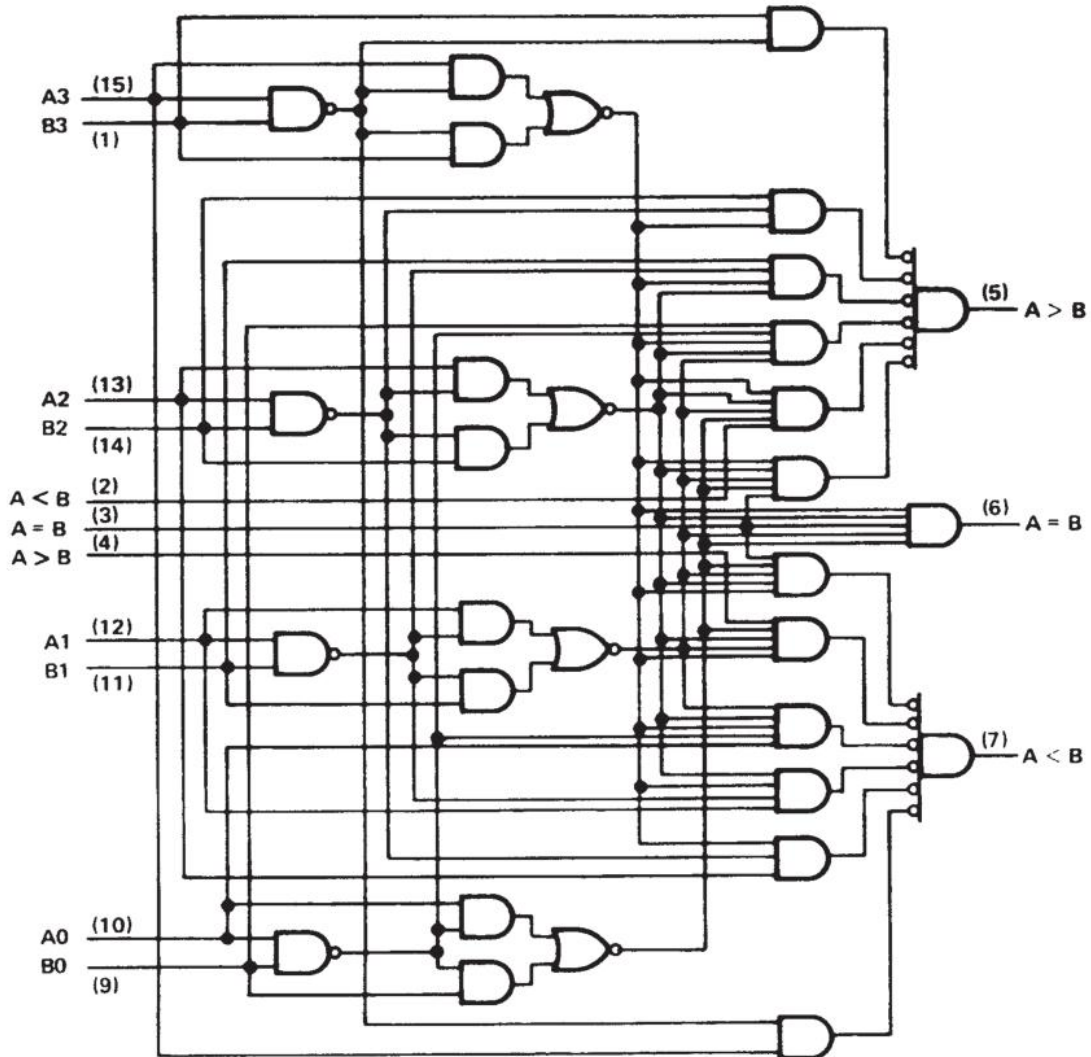

4. LOGIC SYMBOL

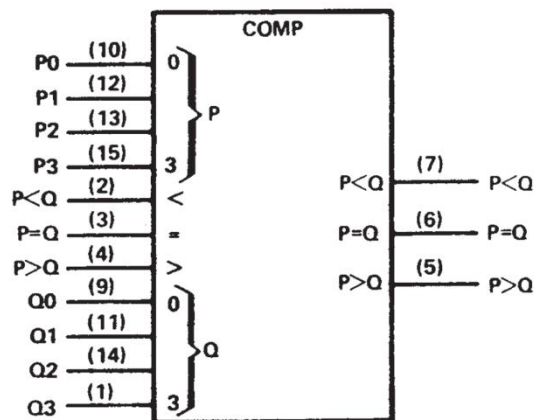

5. SCHEMATICS OF INPUTS AND OUTPUTS

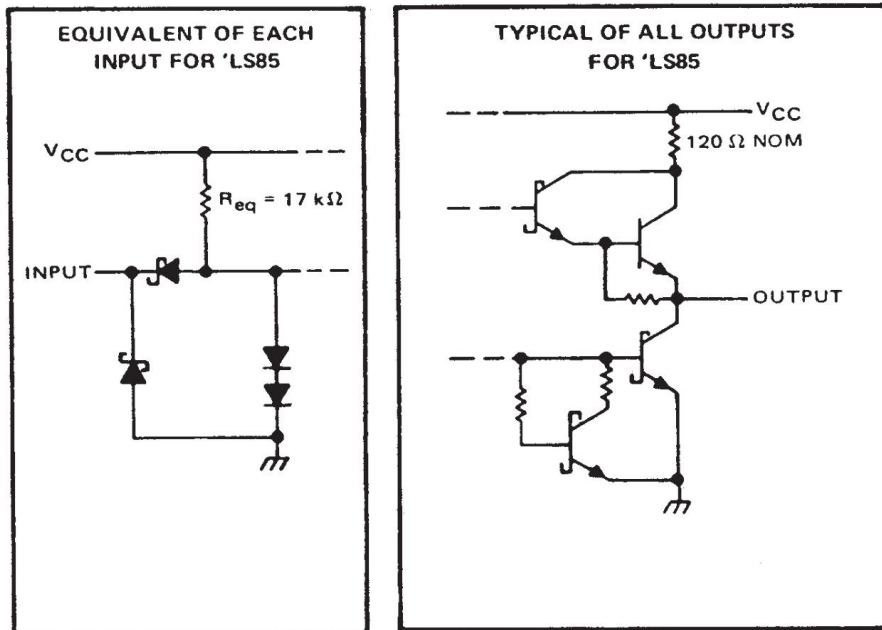

6. ABSOLUTE MAXIMUM RATINGS OVER OPERATING FREE-AIR TEMPERATURE RANGE (UNLESS OTHERWISE NOTES)

Supply voltage, V_{CC}	7V
Input voltage, V_I : 74LS85.....	7V
Operating free-air temperature range: DIP package.....	0°C to 70°C
Storage temperature range, T_{stg}	-65°C to 150°C

† Stresses beyond those listed under "absolute maximum ratings" may cause permanent damage to the device. These are stress ratings only, and functional operation of the device at these or any other conditions beyond those indicated under "recommended operating conditions" is not implied. Exposure to absolute-maximum-rated conditions for extended periods may affect device reliability.

7. RECOMMENDED OPERATING CONDITIONS

		74LS85			UNIT
		MIN	NOM	MAX	
V _{CC}	Supply voltage	4.75	5	5.25	V
I _{OH}	High-level output current			-400	μA
I _{OL}	Low-level output current			8	mA
T _A	Operating free-air temperature	0		70	°C

8. ELECTRICAL CHARACTERISTICS OVER RECOMMENDED OPERATING FREE-AIR RANGE (UNLESS OTHERWISE NOTED)

PARAMETER		TEST CONDITIONS [†]	74LS85			UNIT
			MIN	TYP [‡]	MAX	
V _{IH}	High-level input voltage		2			V
V _{IL}	Low-level input voltage				0.8	V
V _{IK}	Input clamp voltage	V _{CC} = MIN, I _I = -18 mA			-1.5	V
V _{OH}	High-level output voltage	V _{CC} = MIN, V _{IL} = 0.8 V, V _{IH} = 2 V, I _{OH} = -400 μA	2.7	3.4		V
V _{OL}	Low-level output voltage	V _{CC} = MIN, V _{IH} = 2 V, V _{IL} = V _{IL} MAX	I _{OL} = 4 mA	0.25	0.4	V
			I _{OL} = 8 mA	0.35	0.5	
I _I	Input current at maximum input voltage	A < B, A > B inputs			0.1	mA
		all other inputs	V _{CC} = MAX, V _I = 7 V		0.3	
I _{IH}	High-level input current	A < B, A > B inputs	V _{CC} = MAX, V _I = 2.7 V		20	μA
		all other inputs			60	
I _{IL}	Low-level input current	A < B, A > B inputs	V _{CC} = MAX, V _I = 0.4 V		-0.4	mA
		all other inputs			-1.2	
I _{OS}	Short-circuit output current [§]	V _{CC} = MAX	-20		-100	mA
I _{CC}	Supply current	V _{CC} = MAX, Output open, All inputs at 4.5V		10.4	20	mA

[†] For conditions shown as MIN or MAX, use the appropriate value specified under recommended operating conditions.

[‡] All typical values are at V_{CC} = 5 V, T_A = 25°C.

[§] Not more than one output should be shorted at a time.

9. SWITCHING CHARACTERISTICS, VCC = 5 V, TA = 25°C

switching characteristics, VCC = 5 V, TA = 25°C

PARAMETER†	FROM (INPUT)	TO OUTPUT	NUMBER OF GATE LEVELS	TEST CONDITIONS	MIN	TYP	MAX	UNIT
t _{PLH}	Any A or B data input	A<B,A>B	1	C _L = 15 pF, R _L = 2 kΩ	14			ns
			2		19			
		3	24 36					
		4	27 45					
t _{PHL}	Any A or B data input	A<B,A>B	1		11			ns
			2		15			
		3	20 30					
		4	23 45					
t _{PLH}	A<B or A=B	A>B	1		14 22			ns
t _{PHL}	A<B or A=B	A>B	1		11 17			ns
t _{PLH}	A=B	A=B	2	13 20			ns	
t _{PHL}	A=B	A=B	2	13 26			ns	
t _{PLH}	A<B or A=B	A<B	1	14 22				
t _{PHL}	A<B or A=B	A<B	1	11 17				

† t_{PLH} = propagation delay time, low-to-high-level output
t_{PHL} = propagation delay time, high-to-low-level output

10. ORDERING INFORMATION

Ordering Information

Part Number	Device Marking	Package Type	Body size (mm)	Temperature (°C)	MSL	Transport Media	Package Quantity
XD74LS85	XD74LS85	DIP16	19.05 * 6.35	-0 to 70	MSL3	Tube 25	1000

11. DIMENSIONAL DRAWINGS

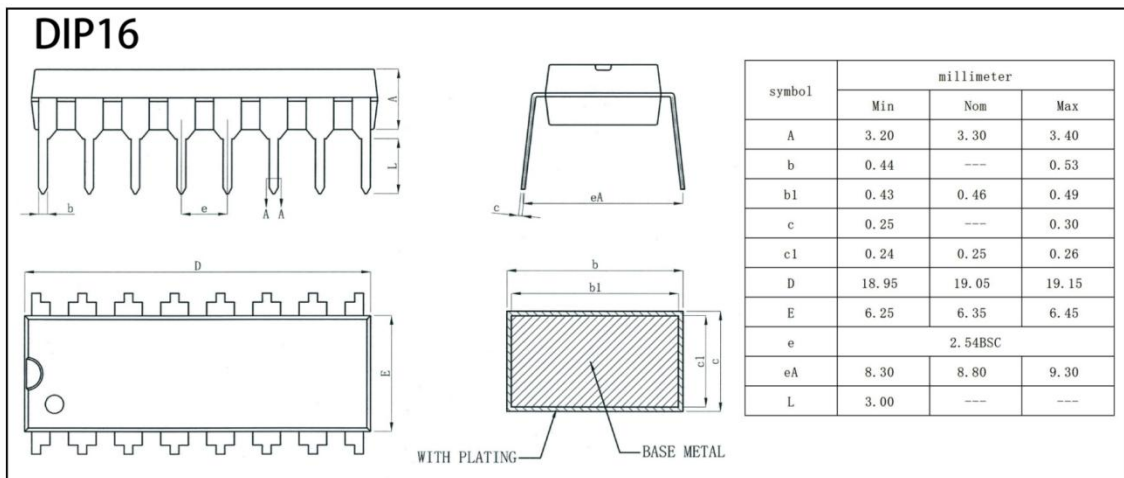

[if you need help contact us. Xinluda reserves the right to change the above information without prior notice]