



UNIU-NE Technology CO., LTD

浙江宇力微新能源科技有限公司



U2103/6 Data Sheet

V 1.1

版权归浙江宇力微新能源科技有限公司

High Current IO+/- 0.5/0.8A HALF-BRIDGE DRIVER

General Description

The U2103/U2106 Fully operated to +600V is high voltage, high speed power MOSFET and IGBT driver with dependent high and low side referenced output channels.

The logic input is compatible with standard CMOS or LSTTL output, down to 3.3V logic. The output drivers feature a high pulse current buffer stage designed for minimum driver cross-conduction. The floating channel can be used to drive an N-channel power MOSFET or IGBT in the high side configuration which operates up to 600 volts.

Product Summary

V _{OFFSET}	600V max
I _{O+/-}	0.5A / 0.8A
V _{OUT}	9V ~ 21V
ton/off (typ.)	680/320 & 120/260ns
Deadtime (typ.)	560 & 50ns
Work Tem	-40 ~ 150 °C

Products Information

Base Part Number	Package Type	Standard OUT		V _{OFFSET}	Logic Control
		IO+	IO-		
U2103	SOP8	0.5A	0.8A	600V	HIN & $\overline{\text{LIN}}$
U2106	SOP8	0.5A	0.8A	600V	HIN & LIN

Key Features

- Floating channel designed for bootstrap operation
- Fully operational to +600V
- Tolerant to negative transient voltage dV/dt immune
- Gate drive supply range from 9 to 21V
- Undervoltage lockout
- 3.3V, 5V and 15V input logic compatible
- Cross-conduction prevention logic
- Matched propagation delay for both channels

Applications

- Home appliances
- Industrial applications and drives
- Motor drivers
- DC- AC Converter, PMDC and PMAC motors
- Induction heating
- HVAC

Packages

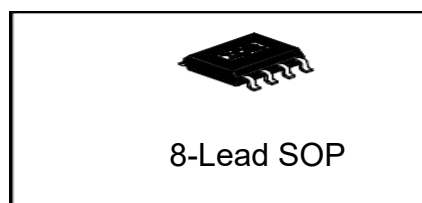

Pin Assignments

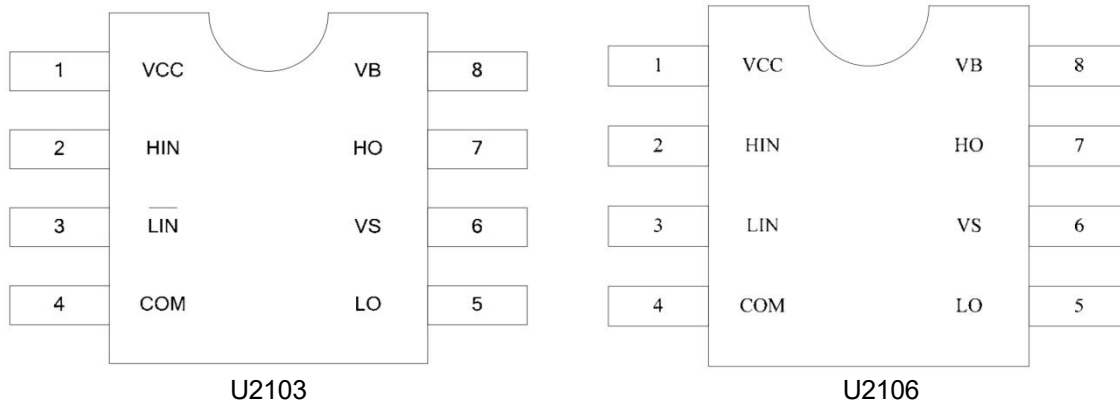

Pin Function

Number	Symbol	Description
1	VCC	Low side and logic fixed supply
2	HIN	Logic input for high side gate driver outputs (HO), in phase
3	LIN	Logic input for low side gate driver outputs (LO), in phase
	$\overline{\text{LIN}}$	Logic input for low side gate driver outputs (LO), out of phase
4	COM	Low side return
5	LO	Low side gate drive output
6	VS	High side floating supply return
7	HO	High side gate drive output
8	VB	High side floating supply

Typical Connection

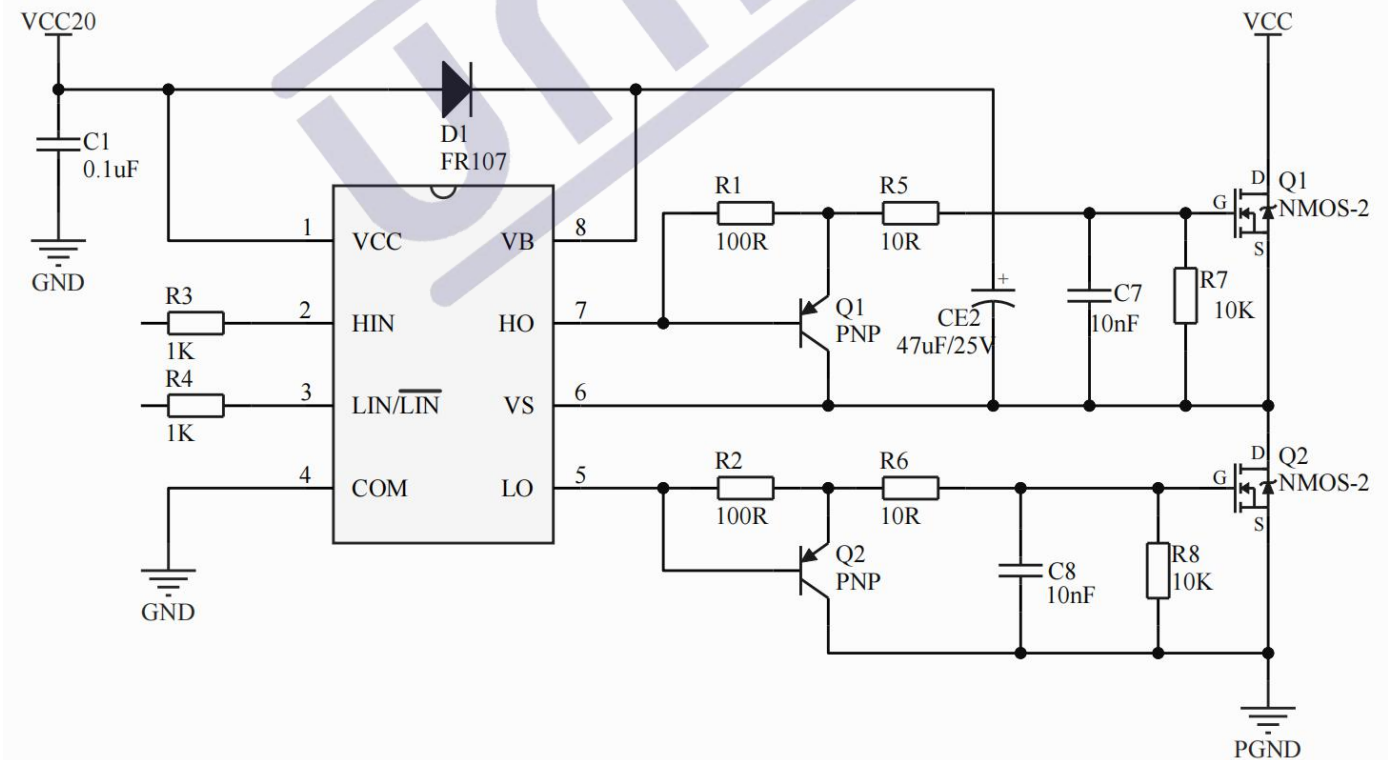
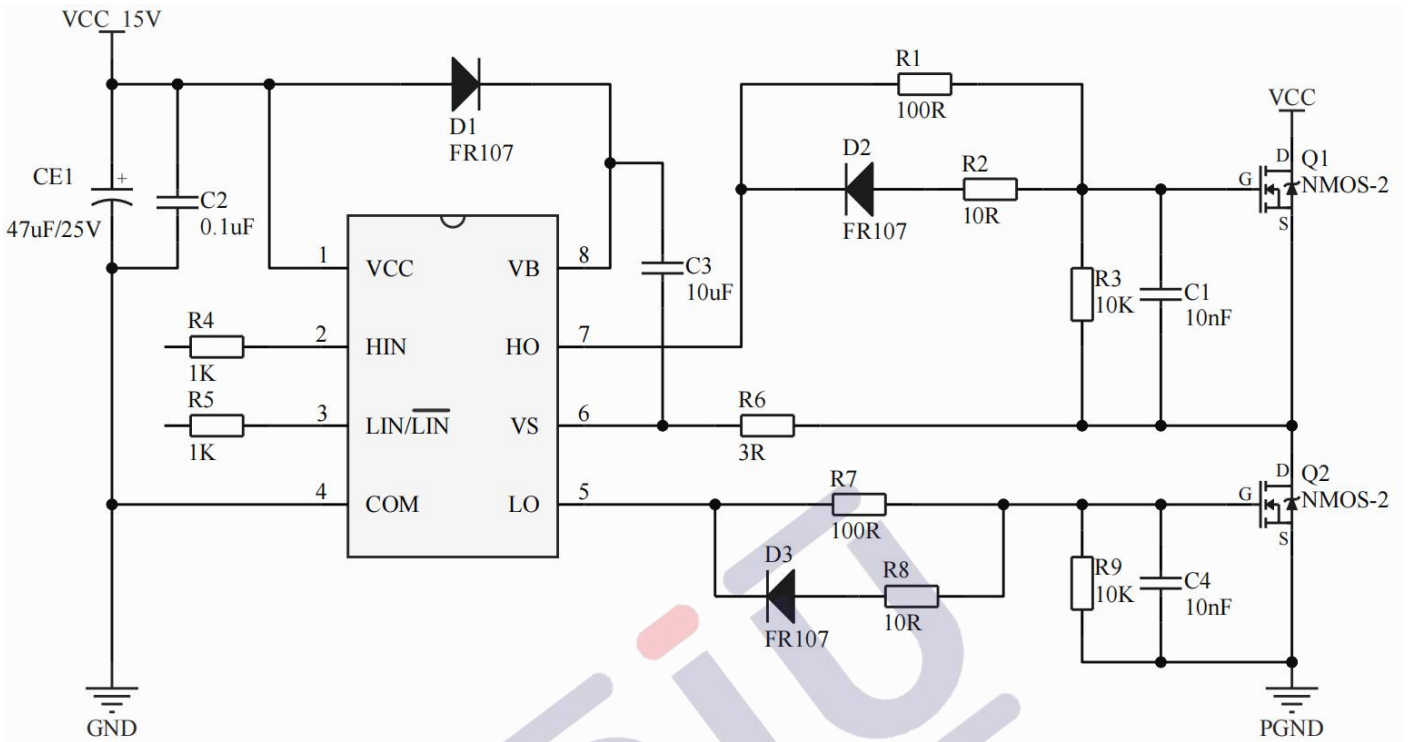

Much Big POWER application

Absolute Maximum Ratings

Absolute maximum ratings indicate sustained limits beyond which damage to the device may occur. All voltage parameters are absolute voltages referenced to COM. The thermal resistance and power dissipation ratings are measured under board mounted and still air conditions.

Symbol	Definition	Min.	Max.	Units
VB	High side floating absolute voltage	-0.3	625	V
VS	High side floating supply offset voltage	VB-25	VB+0.3	
VHO	High side floating output voltage	VS-0.3	VB+0.3	
VLO	Low side output voltage	-0.3	Vcc+0.3	
Vcc	Low side and logic fixed supply voltage	-0.3	25	
VIN	Logic input voltage (HIN & LIN)	-0.3	Vcc+0.3	
dVS/dt	Allowable offset supply voltage transient	—	55	V/ns
P _D	Package power dissipation @ TA ≤ +25°C	—	0.625	W
RthJA	Thermal resistance, junction to ambient	—	200	°C/W
TJ	Junction temperature	-35	150	°C
TS	Storage temperature	-55	150	
TL	Lead temperature (soldering, 10 seconds)	—	300	

Recommended Operating Conditions

The Input/Output logic timing diagram is shown in Figure 1. For proper operation the device should be used within the recommended conditions. The VS offset rating is tested with all supplies biased at 15V differential.

Symbol	Definition	Min.	Max.	Units
VB	High side floating supply absolute voltage	VS + 9	VS + 21	V
VS	High side floating supply offset voltage	-6(Note1)	600	
VHO	High side floating output voltage	VS	VB	
VLO	Low side output voltage	0	VCC	
VCC	Low side and logic fixed supply voltage	9.0	21	
VIN	Logic input voltage (HIN&LIN)	0	VCC	
TA	Ambient temperature	-40	125	°C

Note1: Logic operational for VS of -6 to +600V. Logic state held for VS of -6V to -VBS.

Electrical Characteristic

$V_{CC} = V_{BS} = V_{BIAS} = 15V$, $C_L = 1000pF$, $T_A = 25^\circ C$, unless otherwise specified.

Symbol	Definition		Min.	Typ.	Max.	Units	Test Conditions
tr	Turn-on rise time		—	72	120	ns	
tf	Turn-off fall time		—	15	45		
ton	Turn-on propagation delay	U2103	—	680	800		VS = 0V
		U2106	—	320	380		
toff	Turn-off propagation delay	U2103	—	120	150		VS = 400V
		U2106	—	260	300		
DT	Deadtime, LS turn-off to HS turn-on & HS turn-on to LS turn-off	U2103	—	560	—		
		U2106	—	50	—		
MT	Delay matching, HS & LS turn-on/off		—	—	70		

Electrical Characteristic

$V_{CC} = V_{BS} = V_{BIAS} = 15V$, $T_A = 25^\circ C$, unless otherwise specified.

Symbol	Definition	Min.	Typ.	Max.	Units	Test Conditions
Low Side Power Supply Characteristics						
V_{CCUV+}	VCC supply undervoltage positive going threshold (U2103)	7.7	8.5	9.3	V	
V_{CCUV-}	VCC supply undervoltage negative going threshold (U2103)	7.1	7.9	8.7		
V_{CCHYS}	VCC supply under-voltage lockout hysteresis (U2103)	0.4	0.6	—		
V_{CCUV+}	VCC supply undervoltage positive going threshold (U2106)	7.7	8.5	9.3		
V_{CCUV-}	VCC supply undervoltage negative going threshold (U2106)	7.1	7.9	8.7		
V_{CCHYS}	VCC supply under-voltage lockout hysteresis (U2106)	0.4	0.6	—		
High Side Floating Power Supply Characteristics						
V_{BSUV+}	VBS supply undervoltage positive going threshold (U2103)	7.6	8.4	9.2	V	
V_{BSUV-}	VBS supply undervoltage negative going threshold (U2103)	7.0	7.8	8.6		
V_{BSUVHS}	High side VBS supply under-voltage lockout hysteresis6 (U2103)	0.4	0.6	—		
V_{BSUV+}	VBS supply undervoltage positive going threshold (U2106)	7.6	8.4	9.2		
V_{BSUV-}	VBS supply undervoltage negative going threshold (U2106)	7.0	7.8	8.6		
V_{BSUVHS}	High side VBS supply under-voltage lockout hysteresis6 (U2106)	0.4	0.6	—		

IQCC	Quiescent VCC supply current	—	300	500	uA	$V_{IN} = 0V$ or $5V$
IQBS	Quiescent VBS supply current	—	100	200		$V_{IN} = 0V$ or $5V$
ILK	Offset supply leakage current	—	—	3		$V_B = V_S = 400V$
V_{IH}	Logic "1" (HO) & Logic "0" (LO) input voltage	3	—	—	V	$V_{CC} = 10V$ to $20V$
V_{IL}	Logic "0" (HO) & Logic "1" (LO) input voltage	—	—	0.8		$V_{CC} = 10V$ to $20V$
IIN+	Logic "1" input bias current	—	3	10	uA	$V_{IN} = 5V$ $L_{IN} = 0V$
IIN-	Logic "0" input bias current	—	—	1		$V_{IN} = 5V$ $L_{IN} = 0V$
VOH	High level output voltage, $V_{BIAS} - V_O$	—	—	100	mV	$I_o = 0A$
VOL	Low level output voltage, V_O	—	—	100		$I_o = 0A$
IO+	Output high short circuit pulsed current	—	500	—	mA	$V_O = 0V$, $V_{IN} = V_{IH}$ $PW \leq 10 \mu s$
IO-	Output low short circuit pulsed current	—	800	—		$V_O = 15V$, $V_{IN} = V_{IL}$ $PW \leq 10 \mu s$

Block Diagram

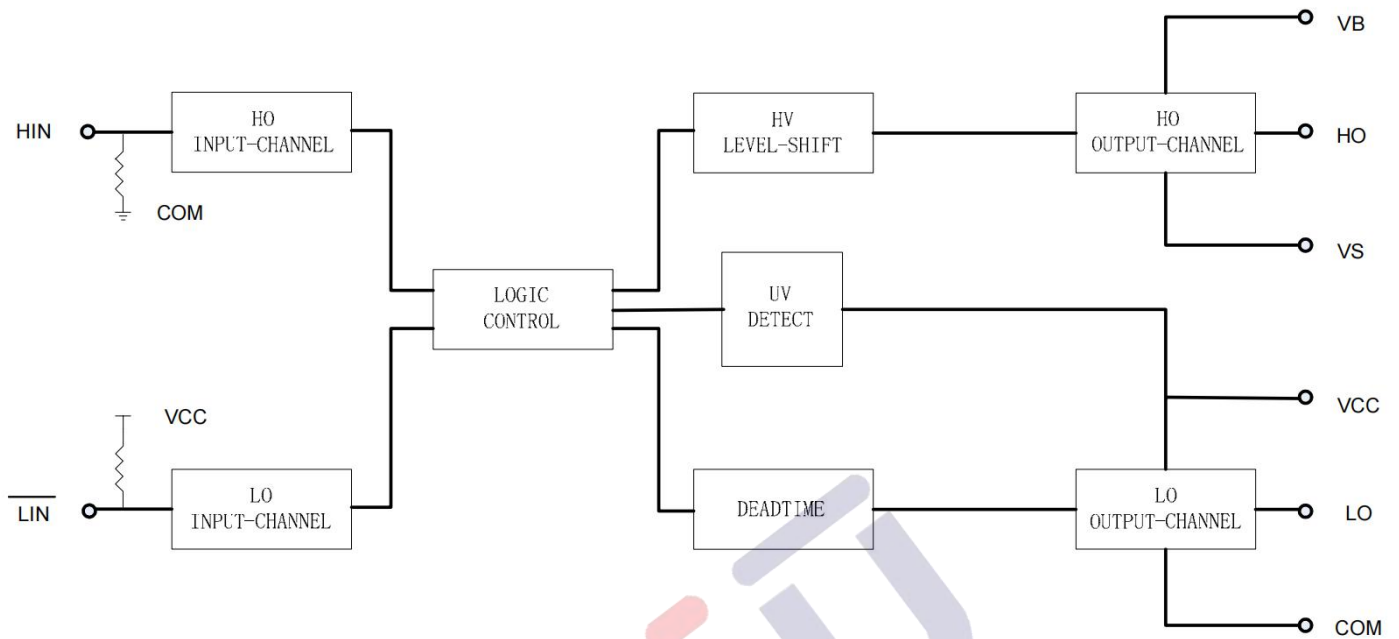

U2103

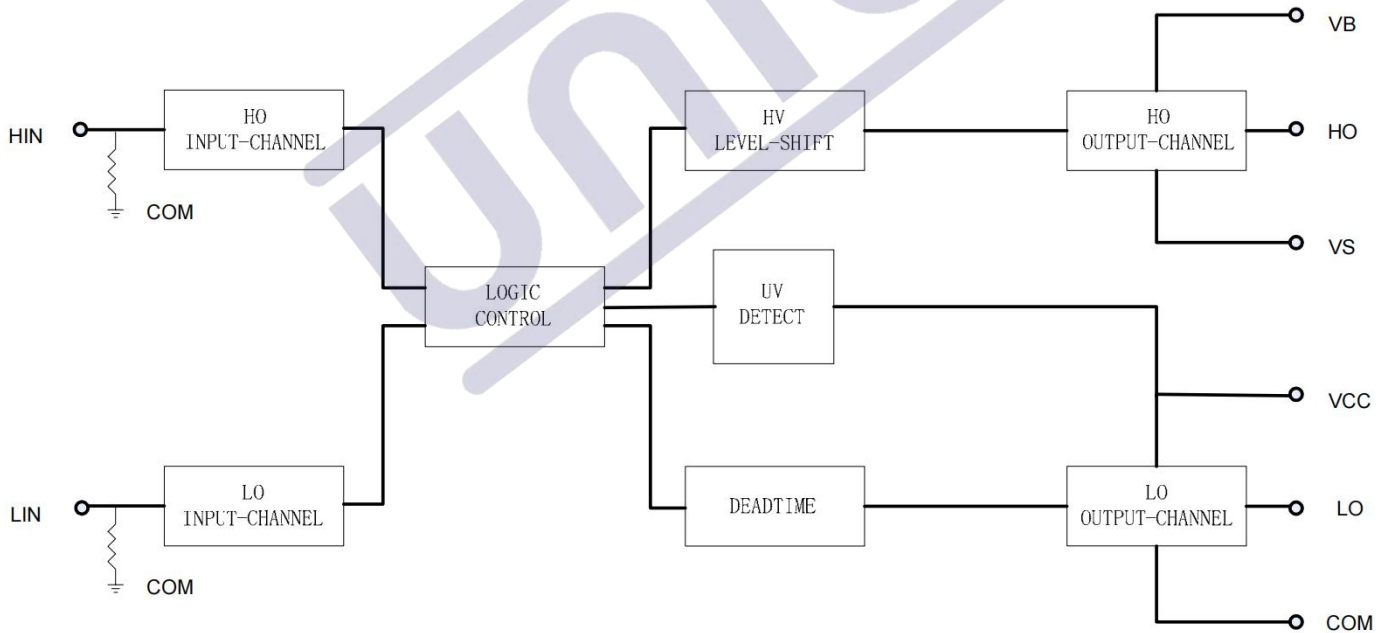

U2106

Time waveform

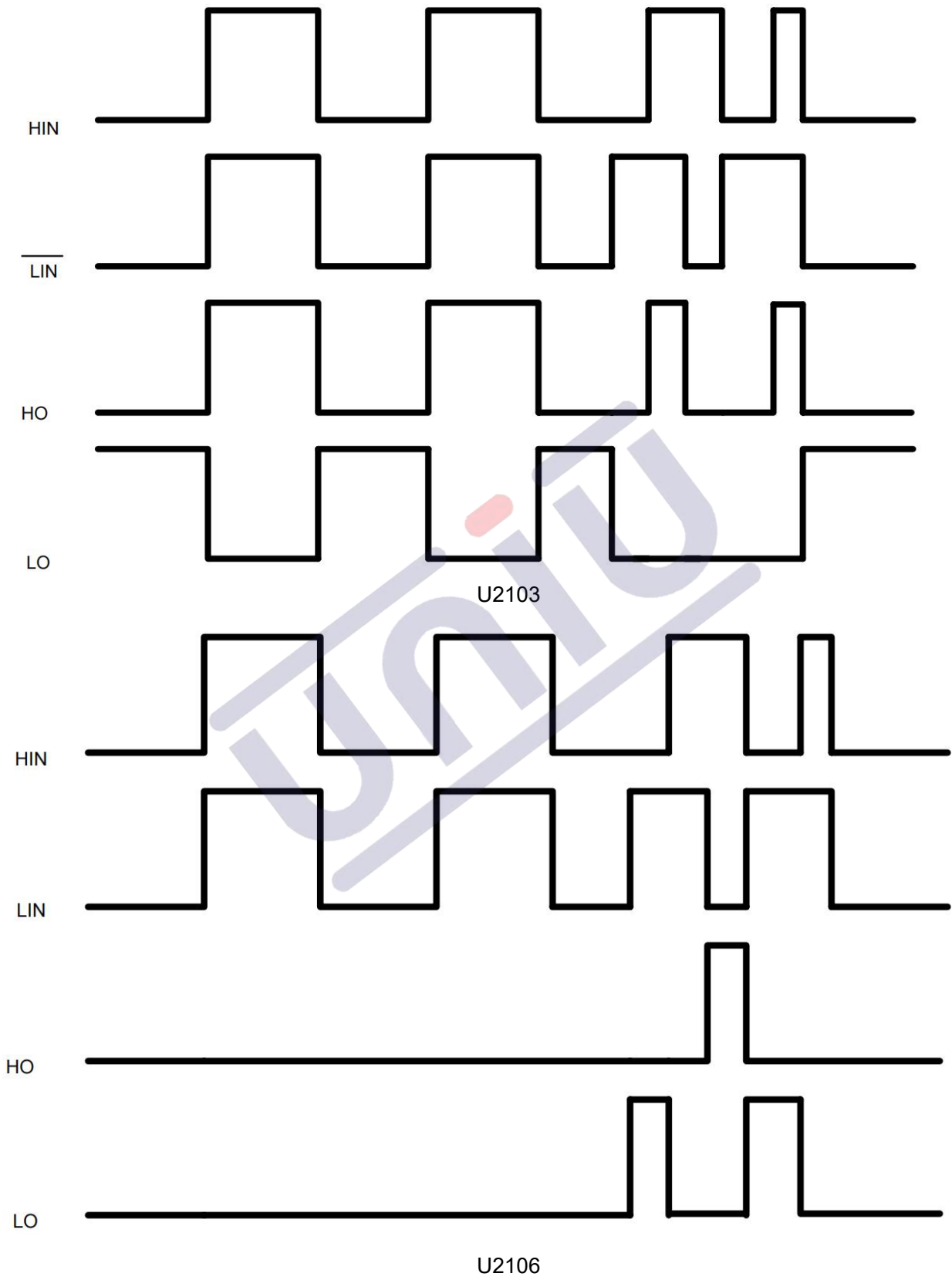

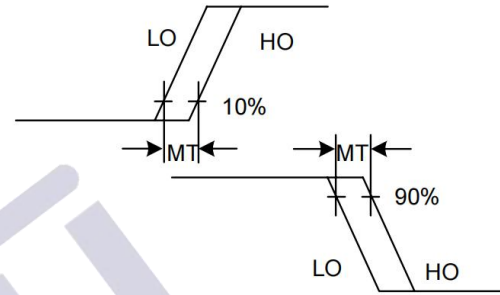
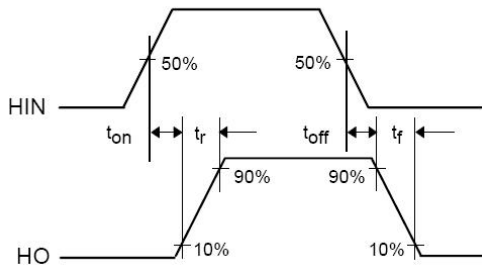
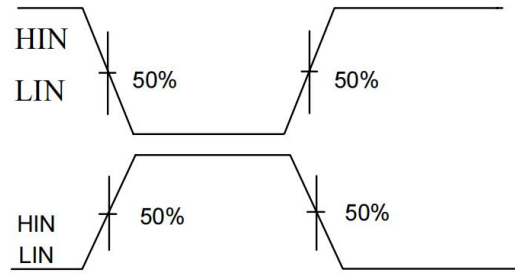
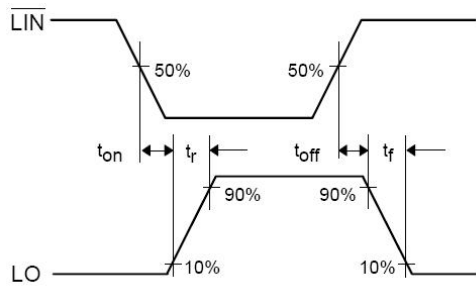

Switching Time Waveform Definitions

Delay matching time Definitions

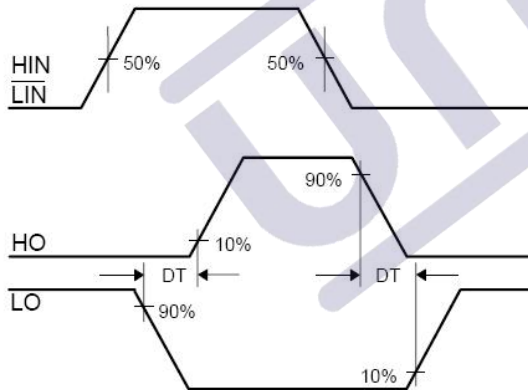

Deadtime Waveform Definitions

Packaging information

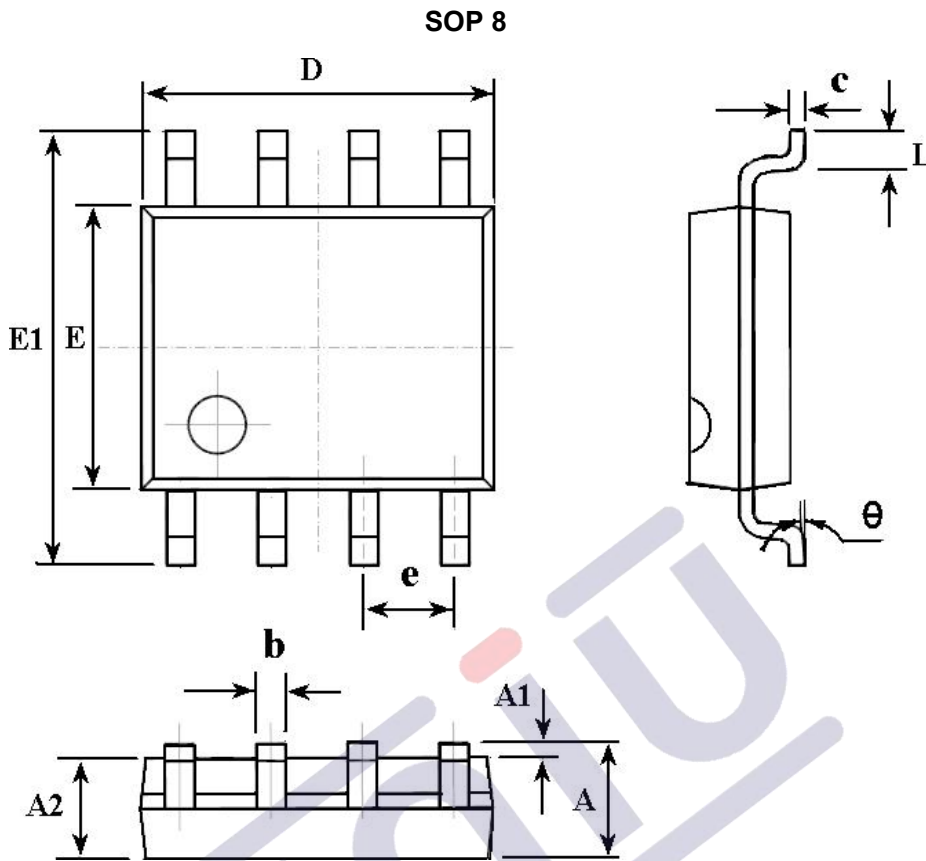

Symbol	Dimensions In Millimeters	
	Min	Max
A	1.350	1.750
A1	0.100	0.250
A2	1.350	1.550
b	0.330	0.510
c	0.170	0.250
D	4.700	5.100
E	3.800	4.000
E1	5.800	6.200
e	1.270(BSC)	
L	0.400	1.270
θ	0°	8°

Tape & Reel 8-lead SOP

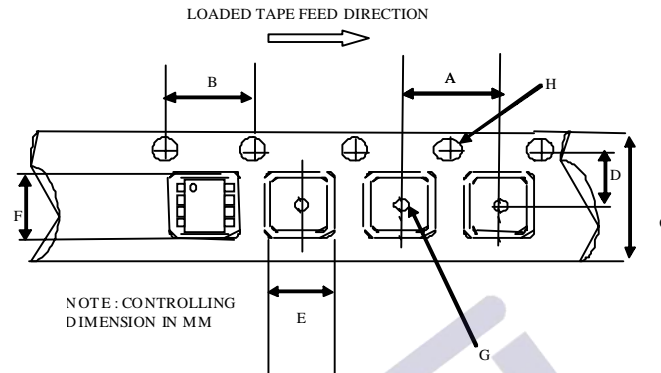

CARRIER TAPE DIMENSION FOR 8SOP

Code	Metric		Imperial	
	Min	Max	Min	Max
A	7.90	8.10	0.311	0.318
B	3.90	4.10	0.153	0.161
C	11.70	12.30	0.46	0.484
D	5.45	5.55	0.214	0.218
E	6.30	6.50	0.248	0.255
F	5.10	5.30	0.200	0.208
G	1.50	n/a	0.059	n/a
H	1.50	1.60	0.059	0.062

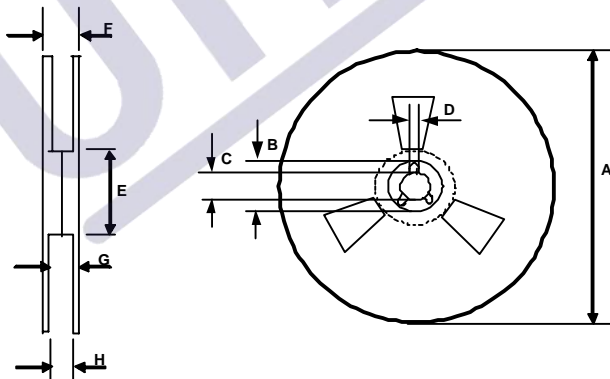

REEL DIMENSIONS FOR 8SOP

Code	Metric		Imperial	
	Min	Max	Min	Max
A	329.60	330.25	12.976	13.001
B	20.95	21.45	0.824	0.844
C	12.80	13.20	0.503	0.519
D	1.95	2.45	0.767	0.096
E	98.00	102.00	3.858	4.015
F	n/a	18.40	n/a	0.724
G	14.50	17.10	0.570	0.673
H	12.40	14.40	0.488	0.566

1.版本记录

DATE	REV.	DESCRIPTION
2018/04/19	1.0	First Release
2020/05/21	1.1	Change the package

2.免责声明

浙江宇力微新能源科技有限公司保留对本文档的更改和解释权力，不另行通知！客户在下单前应获取我司最新版本资料，并验证相关信息是否最新和完整。量产方案需使用方自行验证并自担所有批量风险责任。未经我司授权，该文件不得私自复制和修改。产品不断提升，以追求高品质、稳定性强、可靠性高、环保、节能、高效为目标，我司将竭诚为客户提供性价比高的系统开发方案、技术支持等更优秀的服务。

版权所有 浙江宇力微新能源科技有限公司/绍兴宇力半导体有限公司

3.联系我们

浙江宇力微新能源科技有限公司

总部地址：绍兴市越城区斗门街道袍渎路25号中节能科创园45幢4/5楼

电话：0575-85087896（研发部）

传真：0575-88125157

E-mail: htw@uni-semic.com

无锡地址：无锡市锡山区先锋中路6号中国电子（无锡）数字芯城1#综合楼503室

电话：0510-85297939

E-mail: zh@uni-semic.com

深圳地址：深圳市宝安区西乡街道南昌社区宝源路泳辉国际商务大厦410

电话：0755-84510976

E-mail: htw@uni-semic.com