



Product Summary

Parameter	Value	Unit
V_{DS}	-30	V
$R_{DS(on)}$ (Typ)	$V_{GS} = -10V$	60
	$V_{GS} = -4.5V$	85
Q_g	10	nC

Application

- Load/Power Switching
- Interfacing Switching
- Logic Level Shift

Package and Pin Configuration

SOT-23



Circuit diagram

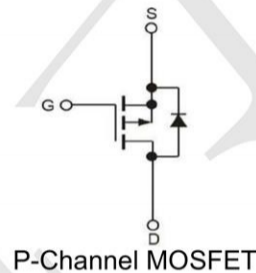

Marking:



Absolute Maximum Ratings ($T_A=25^{\circ}C$ unless otherwise noted)

Parameter	Symbol	Limit	Unit
Drain-Source Voltage	V_{DS}	-30	V
Gate-Source Voltage	V_{GS}	± 20	V
Continuous Drain Current ^(Note 1)	I_D	-3	A
Pulsed Drain Current ^(Note 2)	I_{DM}	-12	A
Continuous Source Current (Diode Conduction)	I_S	-1.7	A
Power Dissipation	P_D	$T_a = 25^{\circ}C$	1.25
		$T_a = 75^{\circ}C$	0.8
Operating Junction Temperature	T_J	+150	$^{\circ}C$
Storage Temperature Range	T_{STG}	-50 to +150	$^{\circ}C$



Thermal Performance

Parameter	Symbol	Limit	Unit
Thermal Resistance - Junction to Case	$R_{\theta JC}$	75	$^{\circ}C/W$
Thermal Resistance - Junction to Ambient	$R_{\theta JA}$	130	$^{\circ}C/W$

Electrical Characteristics ($T_J=25^{\circ}C$, unless otherwise noted)

Parameter	Conditions	Symbol	Min	Typ	Max	Unit
Static						
Drain-Source Breakdown Voltage	$V_{GS} = 0V, I_D = -250\mu A$	BV_{DSS}	-30	--	--	V
Drain-Source On-State Resistance	$V_{GS} = -10V, I_D = -3A$	$R_{DS(ON)}$	--	60	90	$m\Omega$
	$V_{GS} = -4.5V, I_D = -2A$		--	75	110	$m\Omega$
Gate Threshold Voltage	$V_{DS} = V_{GS}, I_D = -250\mu A$	$V_{GS(TH)}$	-1	--	-3	V
Zero Gate Voltage Drain Current	$V_{DS} = -30V, V_{GS} = 0V$	I_{DSS}	--	--	-1.0	μA
Gate Body Leakage	$V_{GS} = \pm 20V, V_{DS} = 0V$	I_{GSS}	--	--	± 100	nA
Forward Transconductance ^(Note 4)	$V_{DS} = -10V, I_D = -6A$	g_{fs}	--	5	--	S
Diode Forward Voltage	$I_S = -1.7V, V_{GS} = 0V$	V_{SD}			-1.2	V
Dynamic						
Total Gate Charge ^(Note 3,4)	$V_{DS} = -15V, I_D = -3A,$ $V_{GS} = -10V$	Q_g	--	10	15	nC
Gate-Source Charge ^(Note 3,4)		Q_{gs}	--	1.9	--	
Gate-Drain Charge ^(Note 3,4)		Q_{gd}	--	2	--	
Input Capacitance	$V_{DS} = -30V, V_{GS} = 0V,$ $f = 1.0MHz$	C_{iss}	--	565	--	pF
Output Capacitance		C_{oss}	--	126	--	
Reverse Transfer Capacitance		C_{rss}	--	75	--	
Switching						
Turn-On Delay Time ^(Note 3,4)	$V_{DD} = -15V, R_L = 15\Omega,$ $I_D = -1A, V_{GEN} = -10V,$ $R_G = 6\Omega$	$t_{d(on)}$	--	10	20	ns
Turn-On Rise Time ^(Note 3,4)		t_r	--	9	20	
Turn-Off Delay Time ^(Note 3,4)		$t_{d(off)}$	--	27	50	
Turn-Off Fall Time ^(Note 3,4)		t_f	--	7	16	



Typical Electrical and Thermal Characteristics

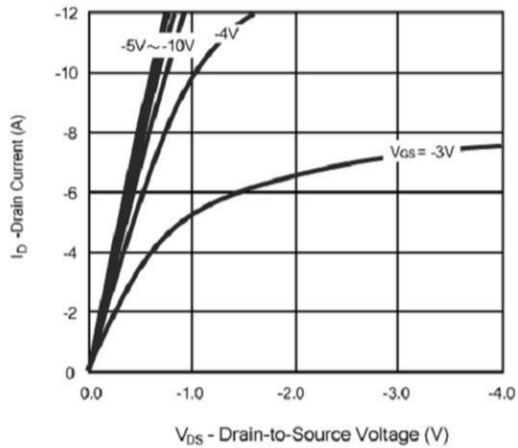

Figure 1. Output Characteristics

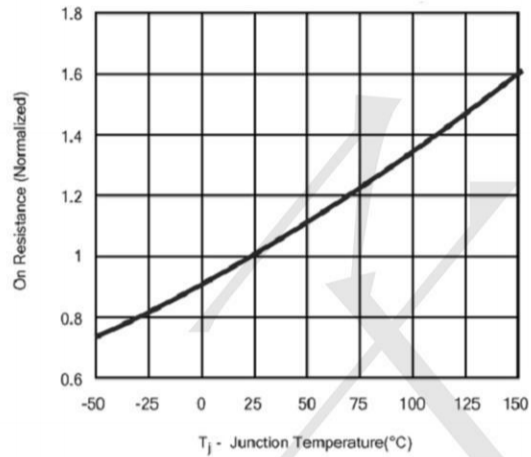

Figure 2. On-Resistance Variation with Temperature

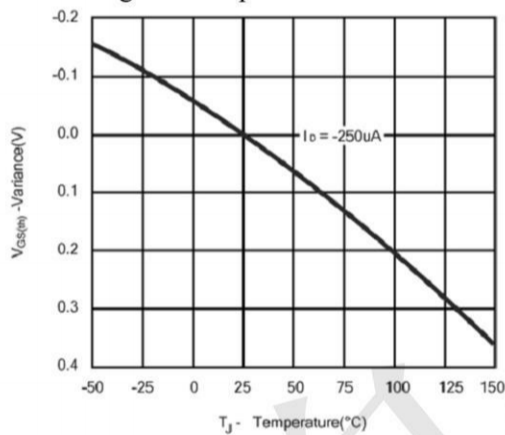

Figure 3. Gate Threshold Variation with Temperatures

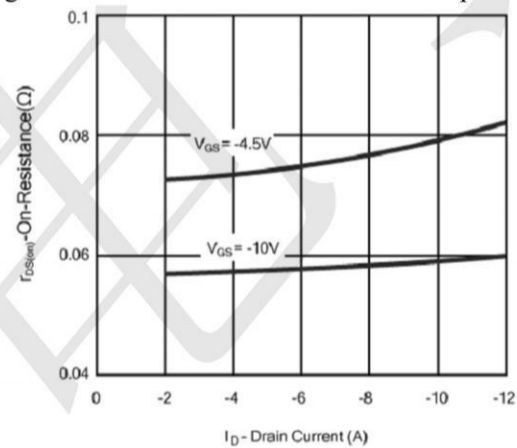

Figure 4. On-Resistance Variation with Drain Current

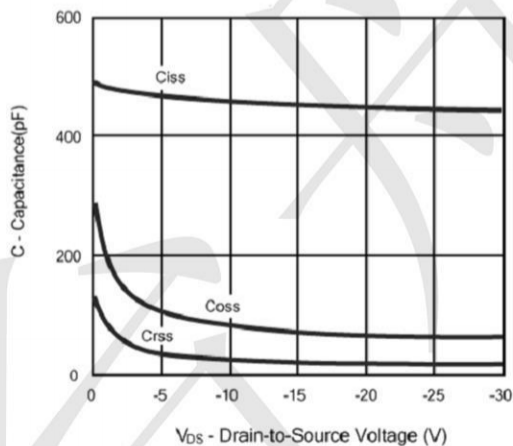

Figure 5. Capacitance Variation with Drain-source Voltage

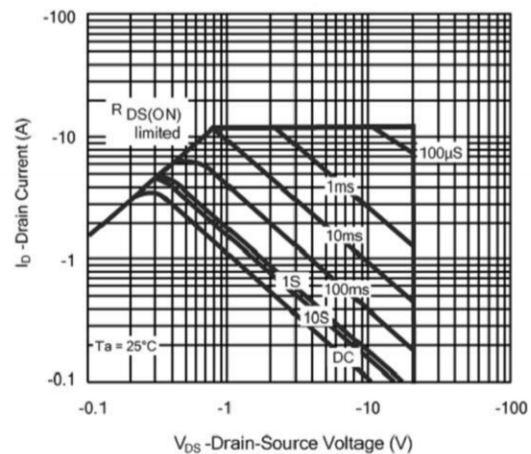
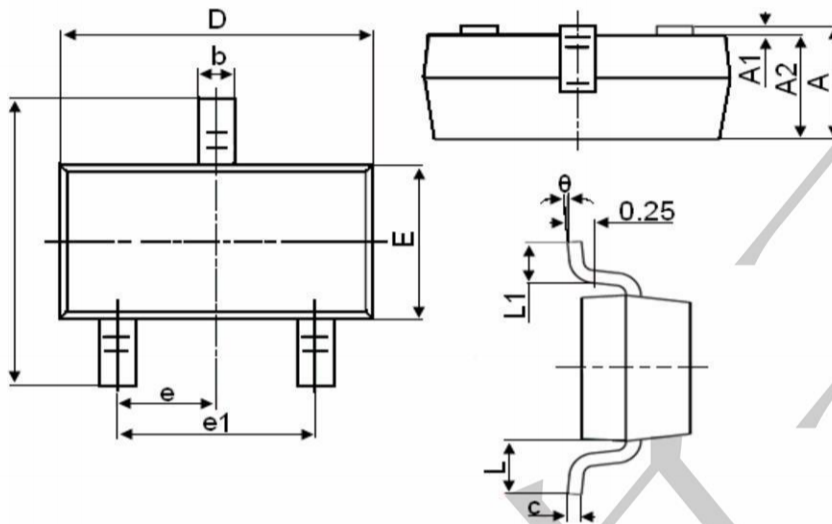

Figure 6. Maximum Safe Operating Area



SOT-23 Package Information



Symbol	Dimensions in Millimeters	
	MIN.	MAX.
A	0.900	1.150
A1	0.000	0.100
A2	0.900	1.050
b	0.300	0.500
c	0.080	0.150
D	2.800	3.000
E	1.200	1.400
E1	2.250	2.550
e	0.950TYP	
e1	1.800	2.000
L	0.550REF	
L1	0.300	0.500
θ	0°	8°