



Silicon Planar Zener Diodes

FEATURES

- Total power dissipation: Max. 500mW.
- Wide zener reverse voltage range 2.0V to 75V.
- Small plastic package suitable for surface mounted design.
- Tolerance approximately $\pm 5\%$

MECHANICAL DATA

- Case: SOD-123
- Terminals: Solderable per MIL-STD-750, Method 2026
- Approx. Weight: 16mg/0.00056oz

PINNING

PIN	DESCRIPTION
1	Cathode
2	Anode



Simplified outline SOD-123 and symbol

Absolute Maximum Ratings And Characteristics (Ta = 25 °C)

Parameter	Symbol	Value	Unit
Power Dissipation	P_{tot}	500	mW
Forward Voltage at $I_F = 10\text{ mA}$	V_F	0.9	V
Typical thermal resistance junction to ambient ⁽¹⁾	$R_{\theta JA}$	340	$^{\circ}\text{C}/\text{W}$
Operating and Storage Temperature Range	T_j, T_{stg}	-55 ~ +150	$^{\circ}\text{C}$

(1) Thermal resistance from junction to ambient at P.C.B. mounted with 2.0" X 2.0" (5 X 5 cm) copper areas pads.

Fig.1 Maximum Continuous Power Derating

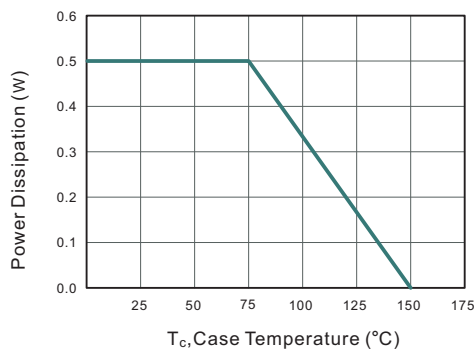
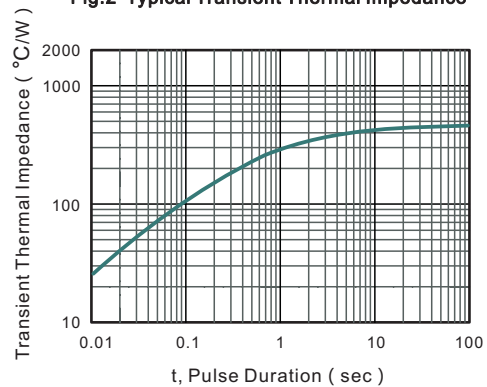

Fig.2 Typical Transient Thermal Impedance





Characteristics at Ta = 25°C

Type	Marking	Zener Voltage Range ⁽¹⁾			I _{ZT} (mA)	Dynamic Impedance Z _{ZT} (at I _{ZT}) Max (Ω)	Reverse Current	
		V _{ZT} (at I _{ZT})					I _R Max (μA)	at V _R (V)
		Min (V)	Nom (V)	Max (V)				
BZT52C2V0	4A	1.8	2.0	2.15	5	100	120	0.5
BZT52C2V2	4B	2.08	2.2	2.33	5	100	120	0.7
BZT52C2V4	4C	2.28	2.4	2.56	5	100	120	1
BZT52C2V7	4D	2.5	2.7	2.9	5	110	120	1
BZT52C3V0	4E	2.8	3.0	3.2	5	120	50	1
BZT52C3V3	4F	3.1	3.3	3.5	5	130	20	1
BZT52C3V6	4H	3.4	3.6	3.8	5	130	10	1
BZT52C3V9	4J	3.7	3.9	4.1	5	130	5	1
BZT52C4V3	4K	4	4.3	4.6	5	130	5	1
BZT52C4V7	4M	4.4	4.7	5	5	130	2	1
BZT52C5V1	4N	4.8	5.1	5.4	5	130	2	1.5
BZT52C5V6	4P	5.2	5.6	6	5	80	1	2.5
BZT52C6V2	4R	5.8	6.2	6.6	5	50	1	3
BZT52C6V8	4X	6.4	6.8	7.2	5	30	0.5	3.5
BZT52C7V5	4Y	7	7.5	7.9	5	30	0.5	4
BZT52C8V2	4Z	7.7	8.2	8.7	5	30	0.5	5
BZT52C9V1	5A	8.5	9.1	9.6	5	30	0.5	6
BZT52C10	5B	9.4	10	10.6	5	30	0.1	7
BZT52C11	5C	10.4	11	11.6	5	30	0.1	8
BZT52C12	5D	11.4	12	12.7	5	35	0.1	9
BZT52C13	5E	12.4	13	14.1	5	35	0.1	10
BZT52C15	5F	13.8	15	15.6	5	40	0.1	11
BZT52C16	5H	15.3	16	17.1	5	40	0.1	12
BZT52C18	5J	16.8	18	19.1	5	45	0.1	13
BZT52C20	5K	18.8	20	21.2	5	50	0.1	15
BZT52C22	5M	20.8	22	23.3	5	55	0.1	17
BZT52C24	5N	22.8	24	25.6	5	60	0.1	19
BZT52C27	5P	25.1	27	28.9	5	70	0.1	21
BZT52C30	5R	28	30	32	5	80	0.1	23
BZT52C33	5X	31	33	35	5	80	0.1	25
BZT52C36	5Y	34	36	38	5	90	0.1	27
BZT52C39	5Z	37	39	41	2.5	100	2	30
BZT52C43	6A	40	43	46	2.5	130	2	33
BZT52C47	6B	44	47	50	2.5	150	2	36
BZT52C51	6C	48	51	54	2.5	180	1	39
BZT52C56	6D	52	56	60	2.5	180	1	43
BZT52C62	6E	58	62	66	2.5	200	0.2	47
BZT52C68	6F	64	68	72	2.5	250	0.2	52
BZT52C75	6H	70	75	79	2.5	300	0.2	57

(1) V_{ZT} is tested with pulses (20 ms)



PACKAGE OUTLINE

Plastic surface mounted package; 2 leads

SOD-123

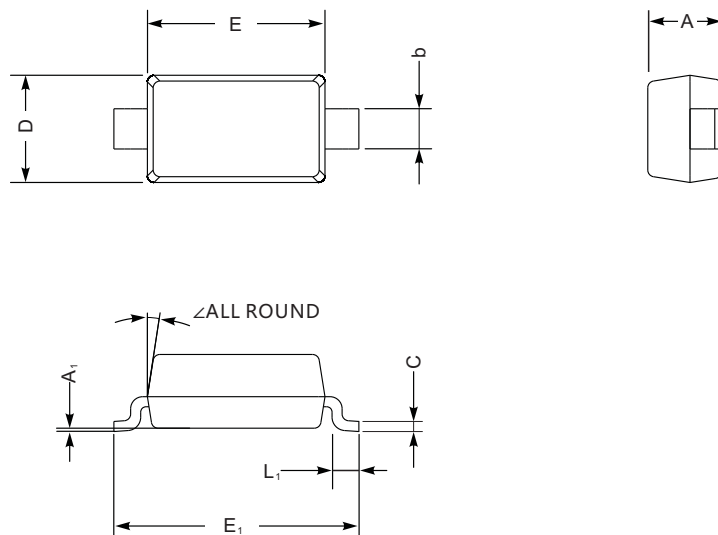

SOD-123 mechanical data

UNIT		A	C	D	E	E ₁	L ₁	b	A ₁	∠
mm	max	1.3	0.22	1.8	2.8	3.9	0.45	0.7	0.2	9°
	min	0.9	0.09	1.5	2.5	3.6	0.25	0.5	—	
mil	max	51	8.7	71	110	154	18	28	8	
	min	35	3.5	59	98	142	10	20	—	

The recommended mounting pad size

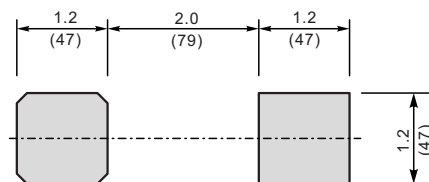

Unit: $\frac{\text{mm}}{\text{(mil)}}$