

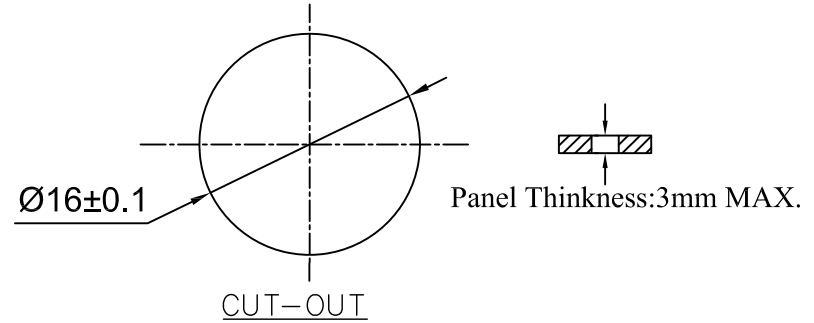

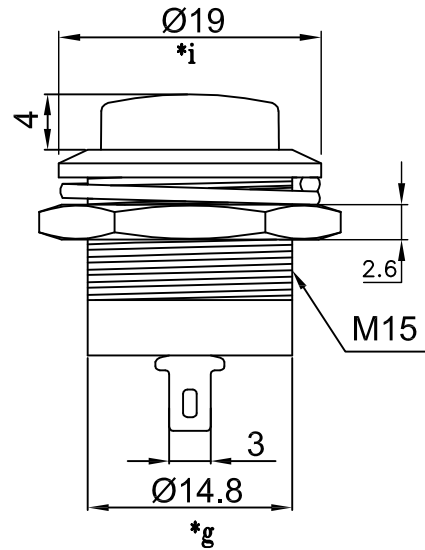

SPECIFICATION

1. Rating : AC250V 3A/AC125V 6A.
2. Contact resistance: $\leq 50m\Omega$.
3. Insulation resistance: $\geq 100M\Omega$ (DC500V).
4. Withstanding voltage: 1000VAC .
5. Operating Force: $250\pm 80gf$
6. Travel: 2.0~2.8mm
7. life test: 50000 cycles.
8. Operation temperature range: $-25^{\circ}C \sim 85^{\circ}C$.
9. Sign"* "is importance dimension.

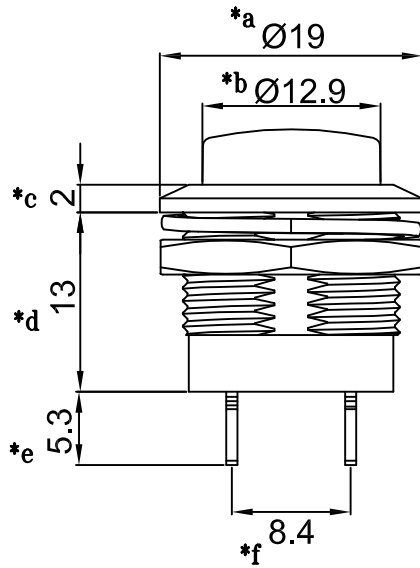

CAP COLOR (X)							
W	B	R	G	U	Y	A	O
White	Black	Red	Green	Blue	Yellow	Gray	Orange

8	WASHER	高碳钢丝	1	Ni-PLATED	TOLERANCE							
7	CONTACT	C1100	1		UNLESS SPECIFIED							
6	NUT	BRASS	1	Ni-PLATED	< 1.5:±0.1mm	ANGULAR	AO	2024. 6. 5	首次发行		YKH	
5	TERMINAL	C1100	2	Ag-PLATED	> 1.5~5.0:±0.25mm	±1°	NO	DATE	REVISIONS		BY	APPD
4	SPRING	SPRING STEEL	1		TITLE: PUSH SWITCH		UNIT : MM	ROHS	DWN			
3	CAP	ABS	1		MODEL: HY-PB02-N-R		SCALE: 1:1	COMPLIANT	CHK'D			
2	BUSHING	PA66	1	BLACK	 DONGGUANG HAOYU ELECTRONICS CO., LTD 皓宇 东莞市弘皓电子有限公司		APPD					
1	BASE	PA66	1	BLACK			PRO.AGL:  		REV :AO			
NO.	PART NAME	MATERIAL	QTY	FINISHING								