

MATERIAL AND FINISH:

Insulator: Thermoplastic, glass filled, black, UL-94V-0 rated.

Contacts (Ground): Brass, Nickel plated

Solder terminals & Contacts (L & N): Brass, Tin plated.

ELECTRICAL SPECIFICATIONS:

Rated current: 10A

Rated voltage: 250VAC



Rated current: 15A

Rated voltage: 250VAC



ENVIRONMENTAL:

Operating temperature: 105°C max.

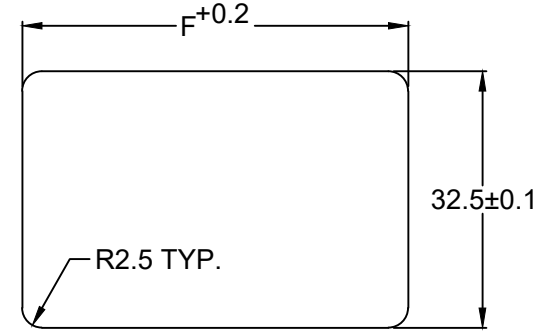
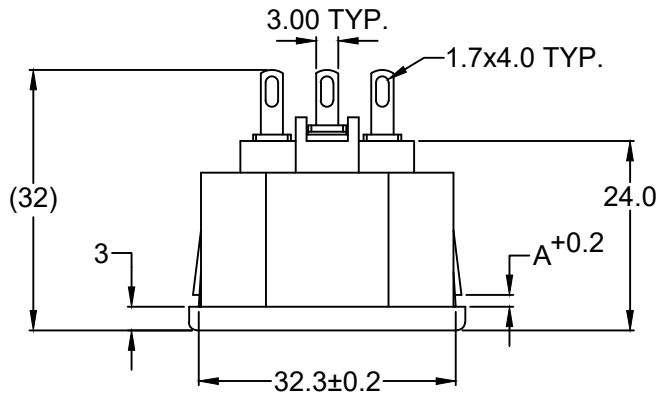

RECOMMENDED
PANEL CUTOUT

No of Port	L	E	F
2	51.2	48.0	48.3
3	75.4	72.0	72.2
4	99.6	96.0	96.2
5	123.2	120.0	120.3
6	147.2	144.0	144.4
7	171.2	168.0	168.4

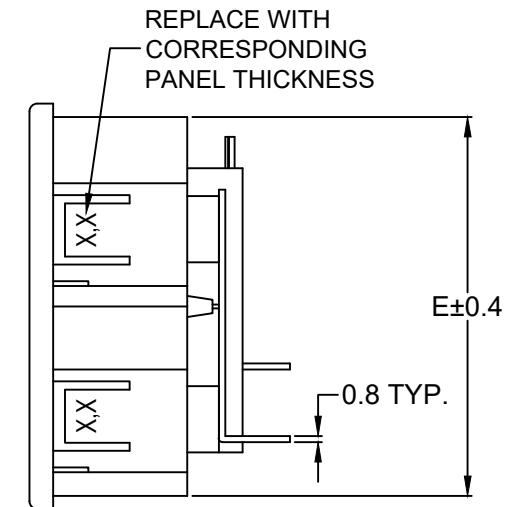
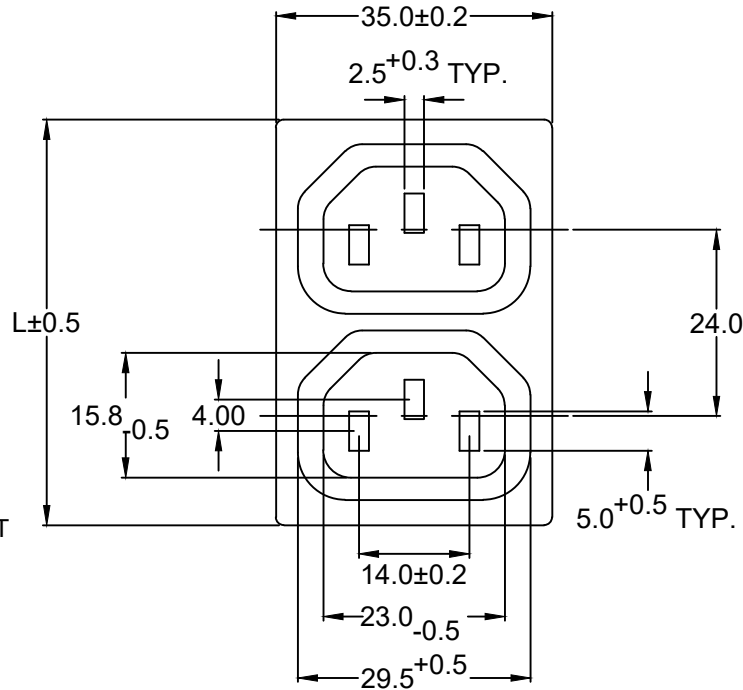

ORDERING CODE:

44R02- 121 -
 1 2

1) NO OF PORT (SEE CHART ABOVE)

2) PANEL THICKNESS

RoHS
COMPLIANT

P/N	A	MAX. PANEL THICKNESS
44R02-X121-120	1.2	1.2
44R02-X121-150	1.5	1.5
44R02-X121-250	2.5	2.5

ADDITIONAL PANEL THICKNESS
AVAILABLE ON REQUEST

TOLERANCE

UNLESS OTHERWISE SPECIFIED

X ± 1
X.X ± 0.4
X.XX ± 0.20

Power Dynamics, Inc.

Phone: 973 560-0019 Whippany, New Jersey Fax: 973 560-0076

PART: IEC 60320 C13 STRIP APPL. OUTLET; SNAP-IN,
SOLDER TERMINAL WITH 1.7x4.0 SLOT

PART #: **44R02-X121-XXX** SHEET 1 of 1

SIZE: A SCALE: NTS ALL DIMENSIONS FOR REFERENCE ONLY
DIMENSIONS ARE IN MILLIMETERS REV: G

REV	DATE	CHANGE	CHNG		CHK		APPR	
			TD	PB	TD	PB	TD	PB
A	8/6/03	UPDATED DIM. & CHART						
B	9/24/03	ADD 1.2mm PANEL THICKNESS						
C	5/27/04	REVISED & UPDATED						
D	1/24/05	CHNG CURRENT RATING, SOLDER HOLE						
E	4/13/10	ADD OPERATING TEMP.						
F	6/22/21	CRUISE CURRENT RATING WAS 20A						
G	9/20/23	FLANGE DIM. WAS 3.00						