

1. Features

- Dual Band Antenna for 2.4--2.5GHz and 4.9 – 5.9 GHz applications:[®]
Wi-Fi 802.11a/h//j/n/p/ac
- Maintains high performance on device: DFI (Designed For Integration)
- Ultra-compact ceramic solution
- SMD mounting
- Supplied on Tape and Reel

2. Description

Minuta is intended for use with 5G Wi-Fi applications. Only requires a small ground plane. Ideal for single and MIMO antenna systems.

3. Applications

- Access Points
- Portable Devices
- PC-cards
- Set-Top-Box
- Network Devices
- Wearable devices
- MIMO Systems
- IP Cameras



4. Part Number

Minuta: SRC2W006

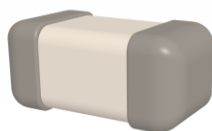

5. General Data

Product name	Minuta
Part Number	SRC2W006
Frequency	2.4-2.5GHz; 4.9-5.9GHz
Polarization	Linear
Operating temperature	-40°C to 140°C
Impedance with matching	50 Ω
Weight	< 0.015 g
Antenna type	SMD
Dimensions	1.0 x 0.5 x 0.5 (mm)
Footprint area	8.0 x 5.0 (mm)

6. RF Characteristics

	Typical performance	Conditions
Peak gain	1.60dBi	2.4 – 2.5 GHz frequency range All data measured on Antenova's evaluation PCB Part No. SRC2W006-EVB-1
Average gain	-2.50dBi	
Average efficiency	>55%	
Maximum return loss	-9.20dB	
Maximum VSWR	2.20:1	

	Typical performance	Conditions
Peak gain	4.00dBi	4.9 – 5.9 GHz frequency range All data measured on Antenova's evaluation PCB Part No. SRC2W005-EVB-1
Average gain	-2.40dBi	
Average efficiency	>50%	
Maximum return loss	-9.80dB	
Maximum VSWR	1.97:1	

7. RF Performance

7.1 Return Loss

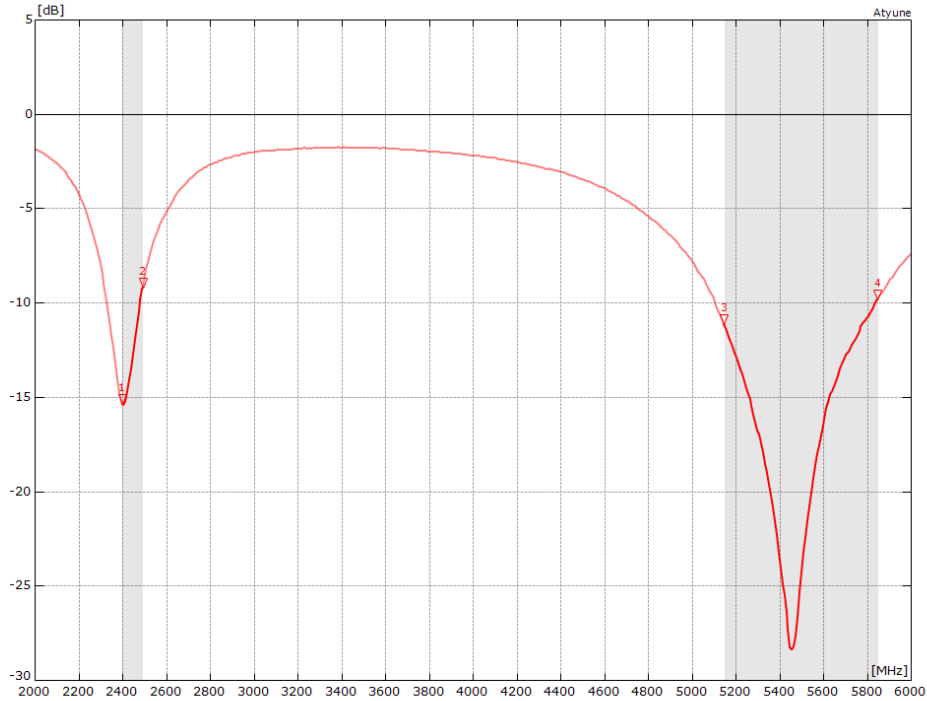

7.2 VSWR

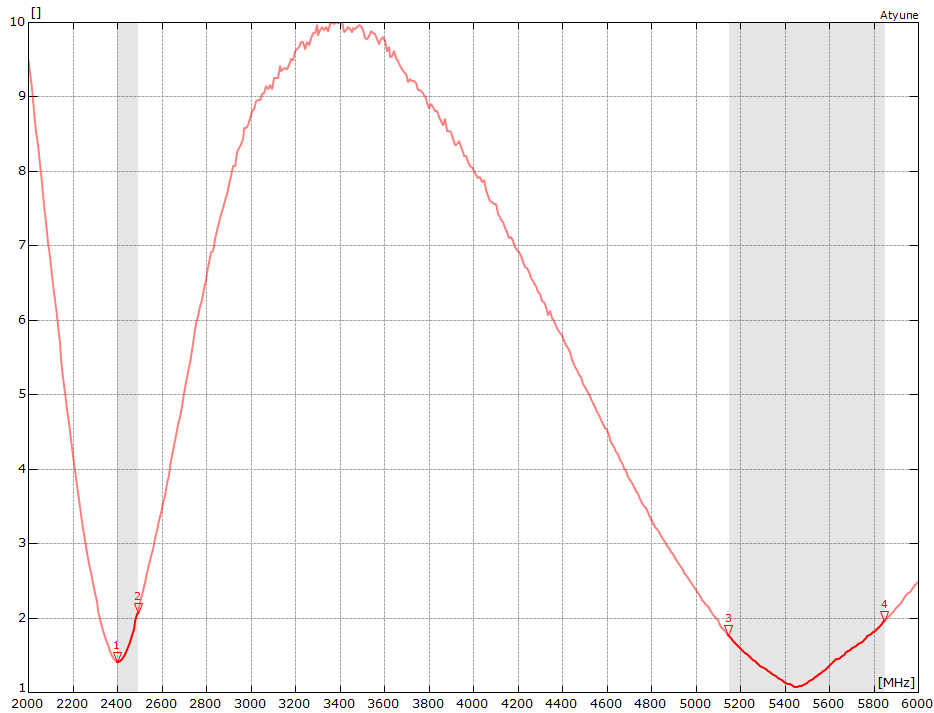

7.3 Antenna patterns

7.3.1 2400 – 2500 MHz

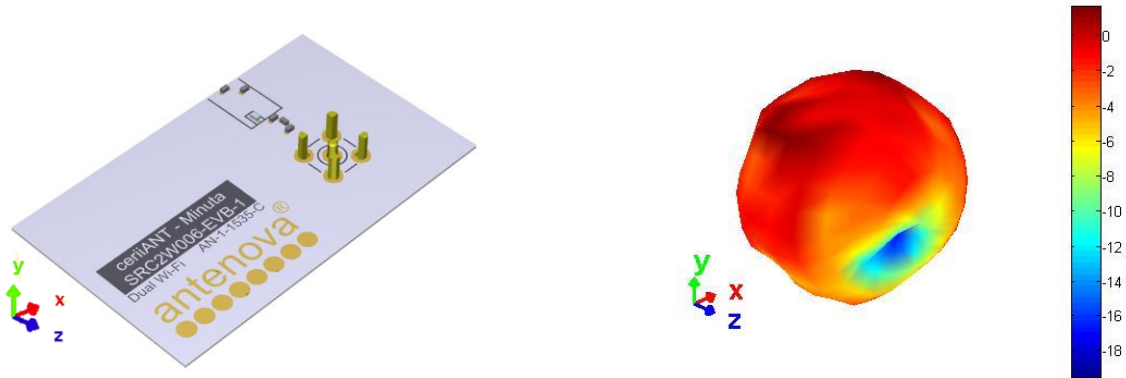

3D pattern at 2.45GHz
*Drag to rotate pattern and PCB by using Adobe Reader
(Click to Activate)*

XY

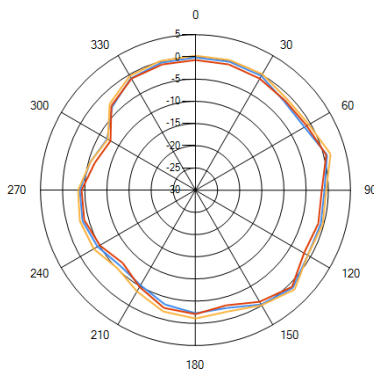

XZ

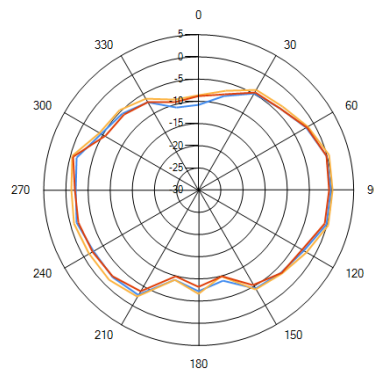

YZ

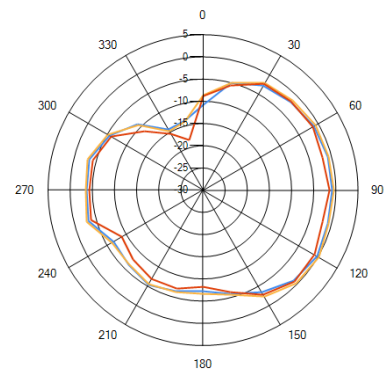

— 2.4GHz — 2.45GHz — 2.5GHz

7.3.2 4900 – 5900 MHz

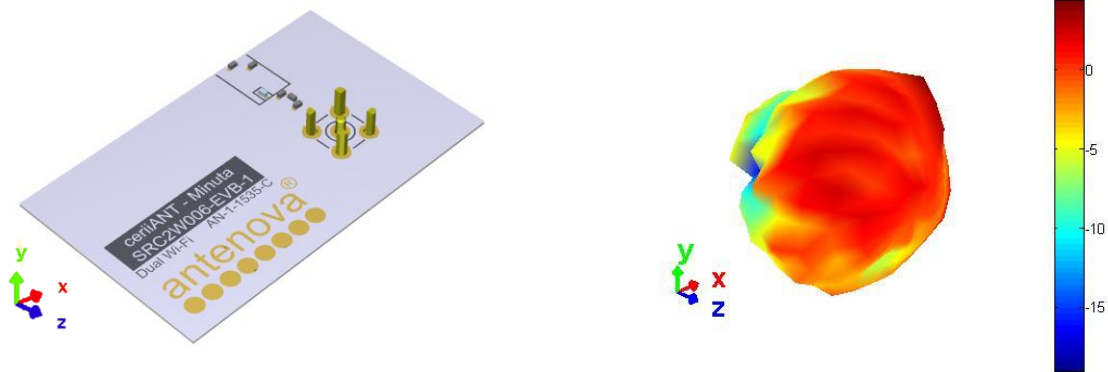

3D pattern at 5.46GHz
*Drag to rotate pattern and PCB by using Adobe Reader
(Click to Activate)*

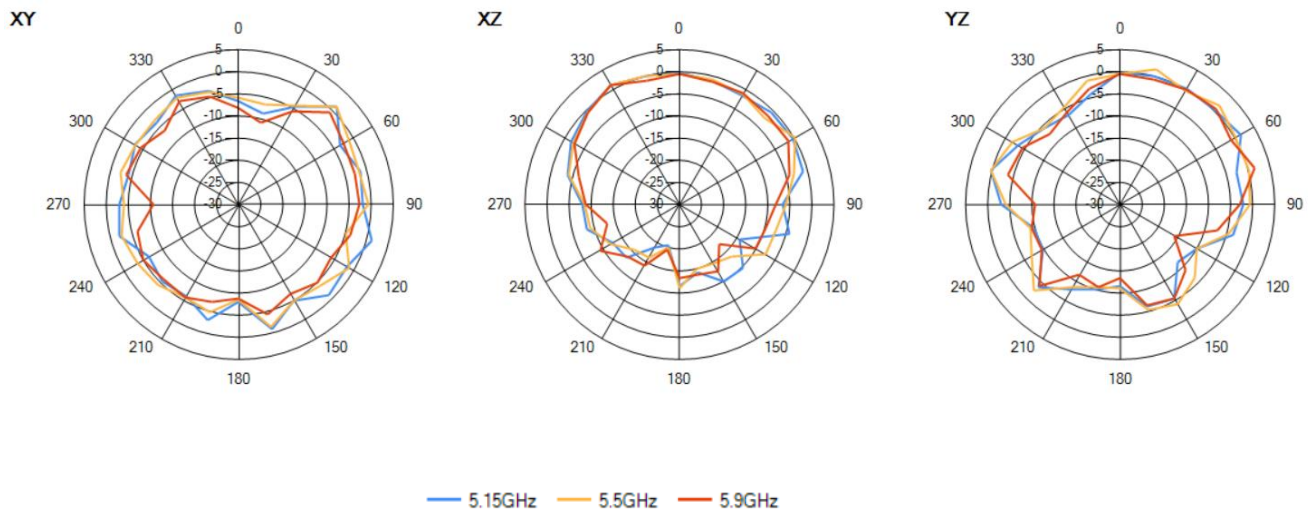

8. Antenna Dimensions

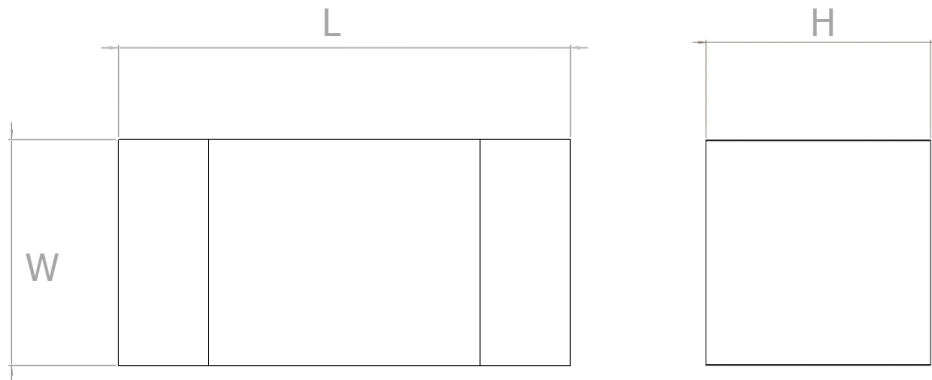

L	W	H
Length	Width	Height
1.0 ±0.1	0.5 ±0.1	0.5 ±0.1

All dimensions in mm

9.0 Antenna footprint

The recommended host PCB footprint is below.

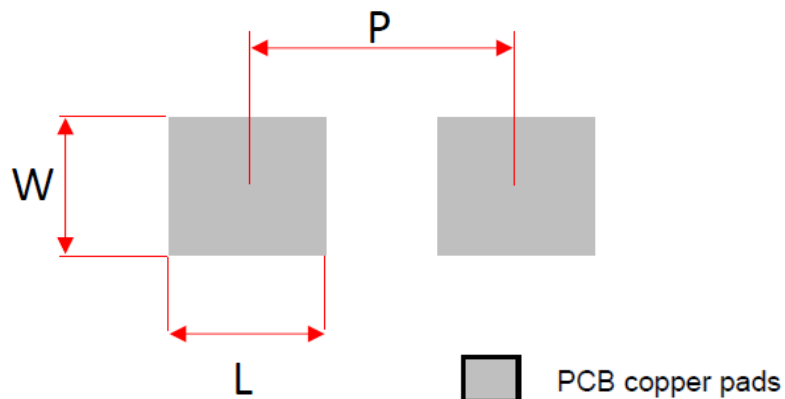

L	W	P
Length	Width	Height
0.6	0.5	1.0

All dimensions in mm

10.0 Schematic

The circuit for the antenna and the matching components is below. The RF feed connection and GND connections are critical to the function of the antenna, and must be followed as shown. This circuit can be used for the circuit capture of the host PCB.

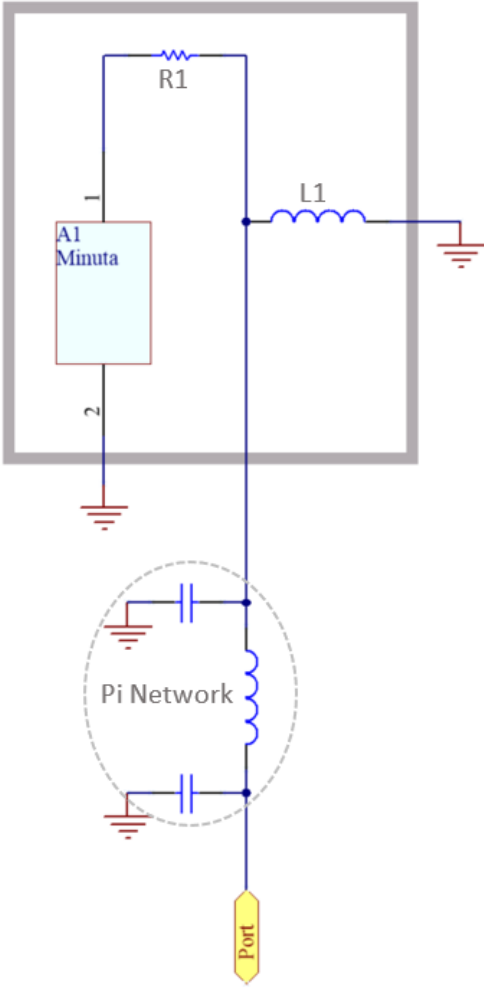

A1	Antenna (SRC2W006)
R1	Tuning Component
L1	Tuning Component

11. Electrical Interface

11.1 Transmission Line

All transmission lines should be designed to have a characteristic impedance of 50Ω.

- The length of the transmission lines should be kept to a minimum
- Any other parts of the RF system like transceivers, power amplifiers, etc, should also be designed to have an impedance of 50 Ω

Once the material for the PCB has been chosen (PCB thickness and dielectric constant), a coplanar transmission line can easily be designed using any of the commercial software packages for transmission line design. For the chosen PCB thickness, copper thickness and substrate dielectric constant, the program will calculate the appropriate transmission line width and gaps on either side of the feed.

11.2 Matching Circuit

The antenna requires a matching circuit that must be optimized for each product. The matching circuit will require up to three components and the following pad layout should be designed into the device so the correct circuit can be installed.

The Pi matching network must be placed close to the antenna feed to ensure it is more effective in tuning the antenna.

An additional tuning component is designed in to aid the tuning of the antenna. This is default not fitted.

12.0 Antenna Placement

The antenna should be placed on the longest side of the PCB. With the antenna greater than 6mm away from the PCB side edge.



12.1 Antenna Clearance

The antenna clearance area should be kept clear on all subsequent PCB layers. Only the top layer with the recommended layout traces are within this area.

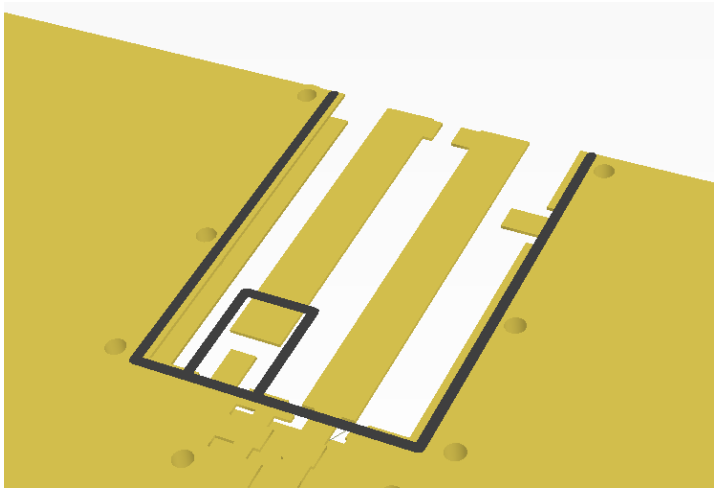

13.0 Reference Board

The reference board has been designed for evaluation of SRC2W006, and includes a SMA female connector.

SRC2W006-EVB-1 Evaluation Board

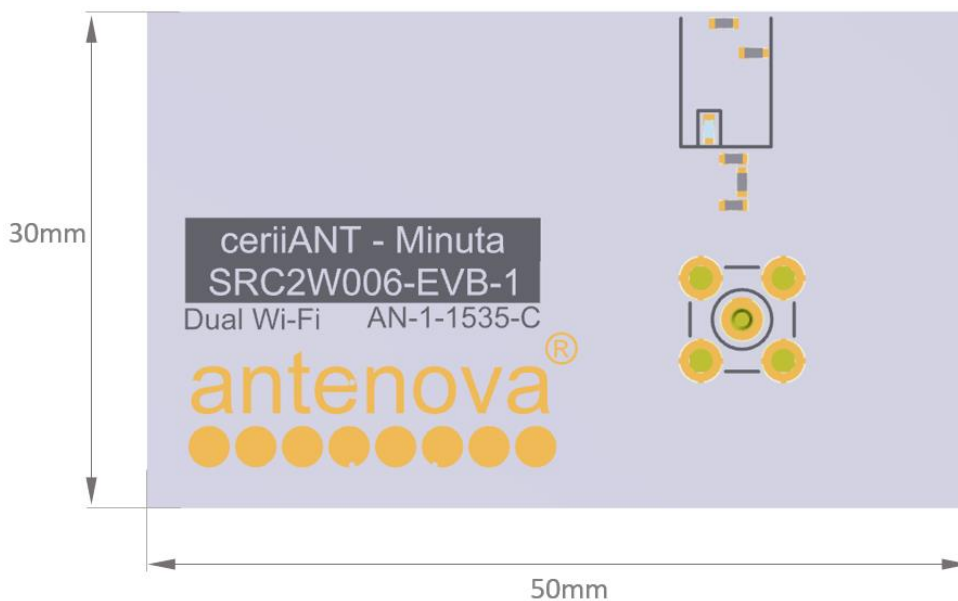

To order a reference board please see www.antenna.com.

13.1 Reference Board Matching Circuit

The reference board has been designed for evaluation purposes of SRC2W006 includes a SMA female connector.

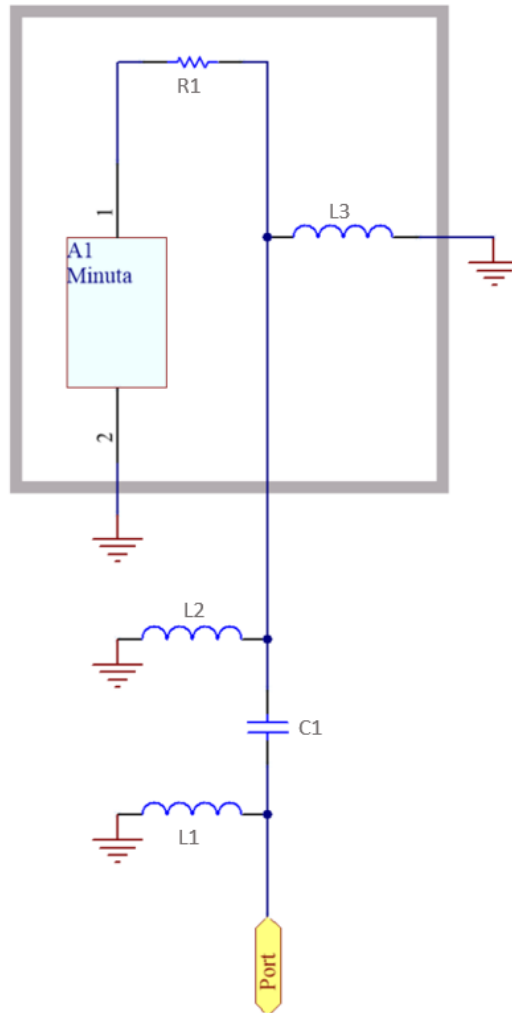

Designator	Type	Value	Description
L1	DNP	Not Fitted	Not Fitted
C1	Capacitor	56pF	Murata GJM15 series
L2	Inductor	2.7nH	Murata LQG15HN series
L3	Inductor	4.7nH	Murata LQG15HN series
R1	Capacitor	4.7pF	Murata GJM15 series

14. Soldering

This antenna is suitable for lead free soldering.

The reflow profile should be adjusted to suit the device, oven and solder paste, while observing the following conditions:

- The maximum temperature should not exceed 240 °C
- However for lead free soldering, a maximum temperature of 255 °C for no more than 20 seconds is permitted.
- The antenna should not be exposed to temperatures exceeding 120 °C more than three times during the soldering process.

15. Hazardous Material Regulation Conformance

The antenna has been tested to conform to RoHS requirements. A certificate of conformance is available from Antenova's website.

16. Packaging

16.1 Optimal Storage Conditions

Temperature	-10°C to 40°C
Humidity	Less than 75% RH
Shelf life	24 Months
Storage place	Away from corrosive gas and direct sunlight
Packaging	Reels should be stored in unopened sealed manufacturer's plastic packaging.

Note: Storage of open reels of antennas is not recommended due to possible oxidization of pads on antennas. If short term storage is necessary, then it is highly recommended that the bag containing the antenna reel is re-sealed and stored in like storage conditions as in above table.

16.2 Tape Characteristics

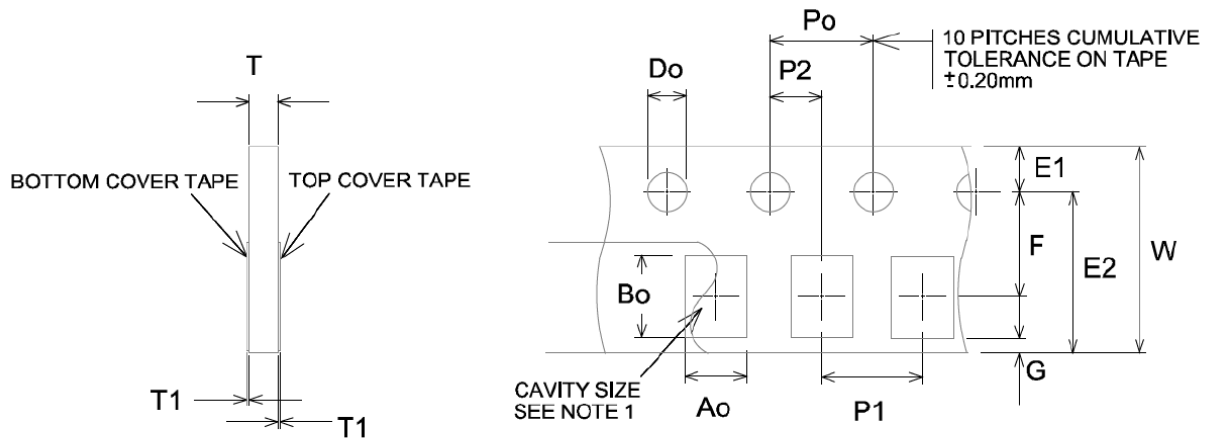

All dimensions in mm

Do	Ao	Bo	P0	P1	P2
1.50 +0.1	See note	See note	4.00 ± 0.1	4.00 ± 0.1	2.00 ± 0.05

E1	E2	W	K0	F	G
1.75 ± 0.1	6.25 ± 0.1	8.00 ± 0.3	1.40 ± 0.1	3.50 ± 0.05	0.75 min

Notes:

The cavity defined by Ao, Bo and T shall be configured to provide sufficient clearance surrounding the antenna so that:

- The component does not protrude beyond either surface of the carrier
- The component can be removed from the cavity in a vertical direction without mechanical restriction after the top cover tape has been removed
- Rotation of the component is limited to 20 degrees maximum.
- Lateral movement of the component is restricted to 0.5mm maximum.

16.3 Reel Dimensions

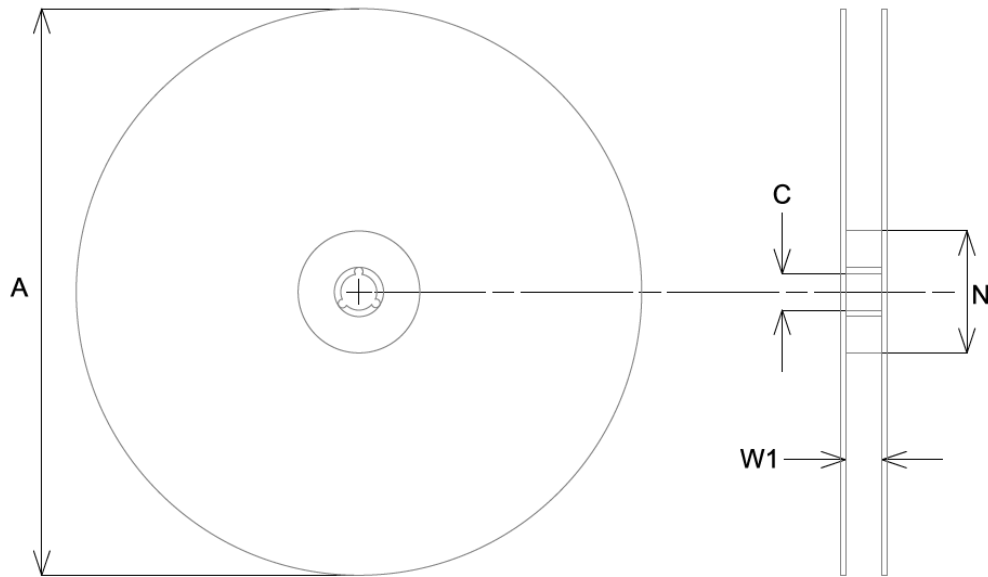

A	C	N	W1
330.0 ± 2.0	13.0 ± 0.5	60.0	8.4.0

All dimensions in mm

Quantity	Leading Space	Trailing Space
10,000 pcs / reel	16 blank holders	24 blank holders

16.4 Box Dimensions

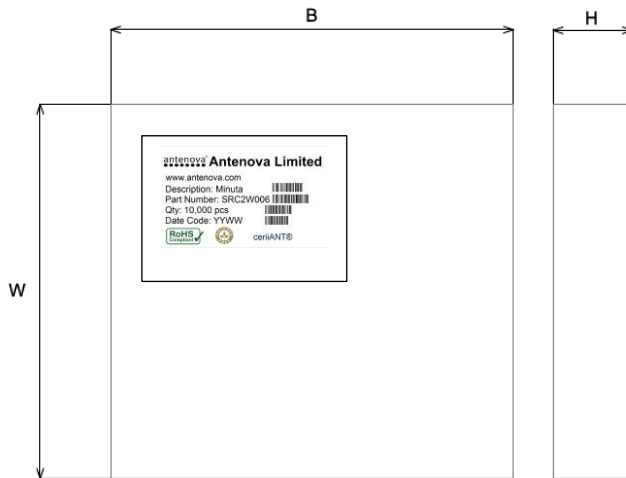

Width (W)	Breadth (B)	Thickness (H)
340mm	350mm	47mm

16.5 Bag Properties

Reels are supplied in protective plastic packaging.

16.6 Reel Label Information



Quality statements

Antenova's products conform to REACH and RoHS legislation. For our statements regarding these and other quality standards, please see www.antenova.com.



Antenna design, integration and test resources

Product designers – the details contained in this datasheet will help you to complete your embedded antenna design. Please follow our technical advice carefully to obtain optimum antenna performance.

It is our goal that every customer will create a high performing wireless product using Antenova's antennas. You will find a wealth of design resources, calculators and case studies to aid your design at our website.

Antenova's design laboratories are equipped with the latest antenna design tools and test chambers. We provide antenna design, test and technical integration services to help you complete your design and obtain certifications.

If you cannot find the antenna you require in our product range, please contact us to discuss creating a bespoke antenna to meet your requirement exactly.

Contacts

Join our online antenna design community: ask.antenova.com

Order antenna samples and evaluation boards at: www.antenova.com

Request a quotation for antennas by volume: sales@antenova.com

Global Headquarters:

**Antenova Ltd, 2nd Floor Titan Court, 3 Bishop Square,
Hatfield, AL10 9NA +44 (0) 1223 810600**

Copyright® Antenova Ltd. All Rights Reserved. Antenova®, gigaNOVA®, RADIONOVA®, the Antenova product family names and the Antenova logos are trademarks and/or registered trademarks of Antenova Ltd. Any other names and/or trademarks belong to their respective companies. The materials provided herein are believed to be reliable and correct at the time of printing. Antenova does not warrant the accuracy or completeness of the information, text, graphics or other items contained within this information. Antenova further assumes no responsibility for the use of this information, and all such information shall be entirely at the user's risk.

Antennas for Wireless Applications

Mouser Electronics

Authorized Distributor

Click to View Pricing, Inventory, Delivery & Lifecycle Information:

[Antenova:](#)

[SRC2W006](#)