

IPS1-1XX-XX-XX-D-VS-XX-XX

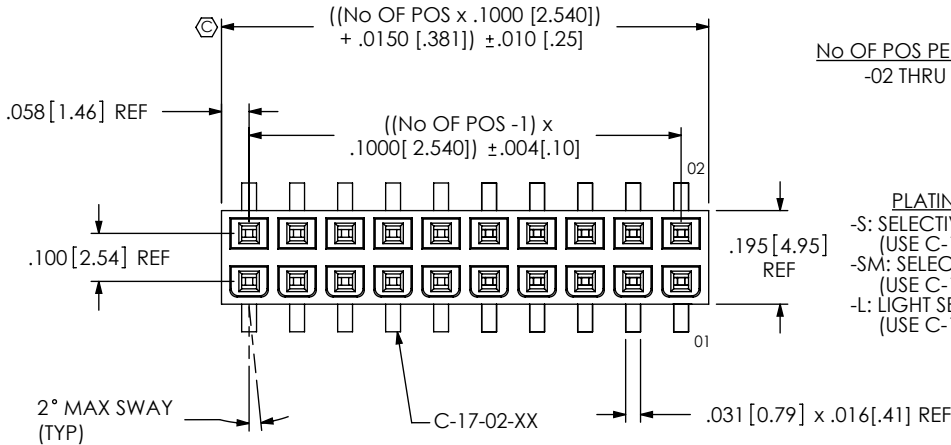

- No OF POS PER ROW**
-02 THRU -25
- LEAD STYLE**
-01
- PLATING SPECIFICATION**
-S: SELECTIVE GOLD, MATTE TIN TAIL (USE C-17-02-S)
-SM: SELECTIVE GOLD, MATTE TIN TAIL (USE C-17-02-S)
-L: LIGHT SELECTIVE GOLD, MATTE TIN TAIL (USE C-17-02-L)
- ROW SPECIFICATION**
-D: DOUBLE (USE IPS1-XX-D)
- OPTION**
-PL: POSITION #1 REMOVED (USE IPS1-XX-D-P) (SEE NOTE 11)
-K: POLYIMIDE FILM PAD [4 POS MIN] (USE K-DOT-.217-.313-.005)
-TR: TAPE & REEL PACKAGING
- OPTION**
-LC: LOCKING CLIP (USE LC-07-TM) (SEE NOTE 10)
-FL: FRICTION LOCK (USE IPS1-XX-D-FL-X) [POSITIONS -05 THRU -25]
- TAIL OPTION**
-VS: VERTICAL SURFACE MOUNT

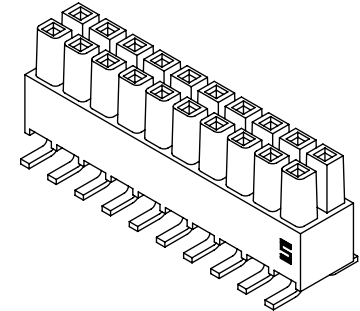

DO NOT SCALE FROM THIS PRINT

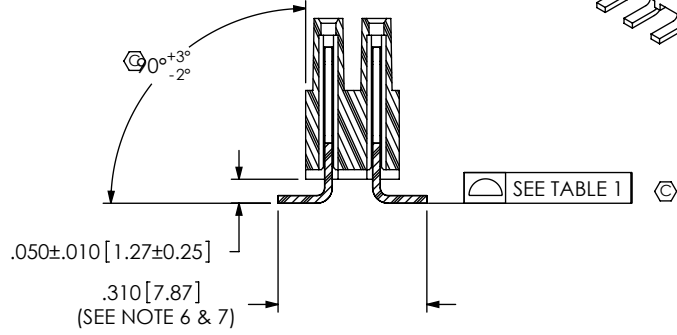
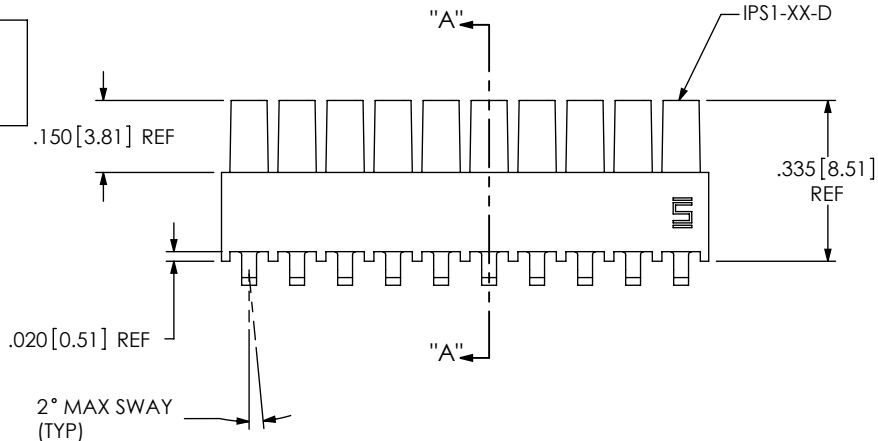

NOTES:

SECTION "A"-"A"

1. C REPRESENTS A CRITICAL DIMENSION.
2. MAXIMUM ALLOWABLE CUT FLASH: $.010 [0.25]$.
3. MINIMUM CONTACT PUSH OUT FORCE: 1.5 lbs.
4. MAXIMUM ALLOWABLE BOW: $.003 [0.08]$ INCH/INCH AFTER ASSEMBLY.
5. MAXIMUM VARIATION BETWEEN PIN ROWS: $.010 [0.25]$.
6. SHEAR TAILS TO ACHIEVE DIMENSION SHOWN.
7. SHEAR BURR ALLOWED ON TOP SIDE (MOLD SIDE) TO $.005 [0.13]$ MAX.
8. "END WALLS" AFTER CUTTING SHOULD BE $.015 + / - .003 [0.38 + / - .08]$.
9. AFTER REVISION N OF COMPONENT IPS1-XX-D-XX-X, SAMTEC LOGO TO APPEAR ON #1 POSITION.
10. DUE TO THE HIGH AMOUNT OF INSERTION FORCE NEEDED, THE -LC OPTION IS NOT COMPATIBLE WITH AUTO PLACEMENT. SAMTEC RECOMMENDS MANUAL PLACEMENT FOR ALL ASSEMBLIES WITH THE -LC OPTION.
11. FOR EXISTING CUSTOMERS ONLY, -POL CAN BE SUBSTITUTED FOR -PL.

UNLESS OTHERWISE SPECIFIED, DIMENSIONS ARE IN INCHES. TOLERANCES ARE: DECIMALS ANGLES .XX: $\pm .01 [0.3]$ $\pm 2^\circ$.XXX: $\pm .005 [0.13]$.XXXX: $\pm .0020 [0.051]$	PROPRIETARY NOTE THIS DOCUMENT CONTAINS INFORMATION CONFIDENTIAL AND PROPRIETARY TO SAMTEC, INC. AND SHALL NOT BE REPRODUCED OR TRANSFERRED TO OTHER DOCUMENTS OR DISCLOSED TO OTHERS OR USED FOR ANY PURPOSE OTHER THAN THAT WHICH IT WAS OBTAINED WITHOUT THE EXPRESSED WRITTEN CONSENT OF SAMTEC, INC.		
		520 PARK EAST BLVD. NEW ALBANY, IN 47150 PHONE: 812-944-6733 FAX: 812-948-5047 e-Mail: info@SAMTEC.com code 55322	
MATERIAL: DO NOT SCALE DRAWING SHEET SCALE: 2.5:1		DESCRIPTION: .100 DOUBLE ROW SHROUDED SOCKET ASSEMBLY	
INSULATOR: VECTRA E130i; COLOR: BLACK CONTACT: PHOS BRONZE, 510 SPRING TEMPER		DWG. NO. IPS1-1XX-XX-XX-D-VS-XX-XX	
F:\DWG\MISC\MKTG\IPS1-1XX-XX-XX-D-VS-XX-XX-MKT.SLDDRW		BY: DEAN P 10-30-2002 SHEET 1 OF 2	

POSITION	COPLANARITY
-04 THRU -10	$.005 [0.13]$
-11 THRU -25	$.006 [0.15]$

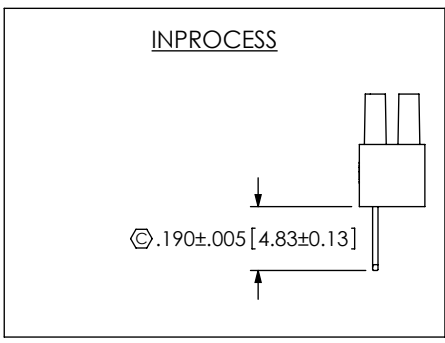
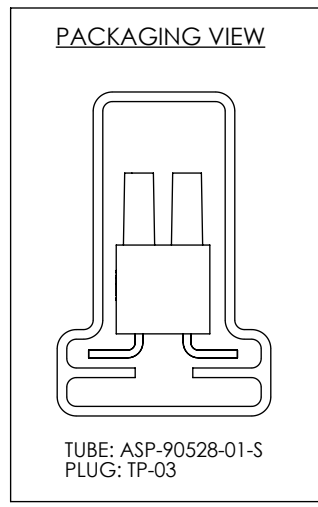

-FL: FRICTION LOCK OPTION
 IPS1-110-01-X-D-VS-FL SHOWN

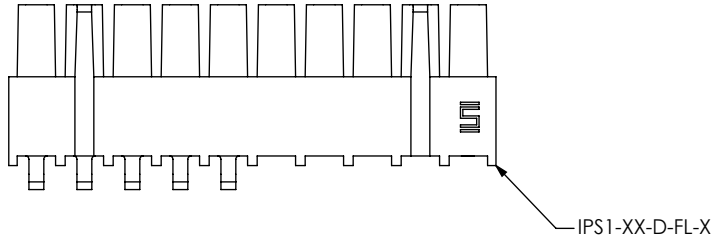

-K: POLYAMIDE FILM PAD OPTION

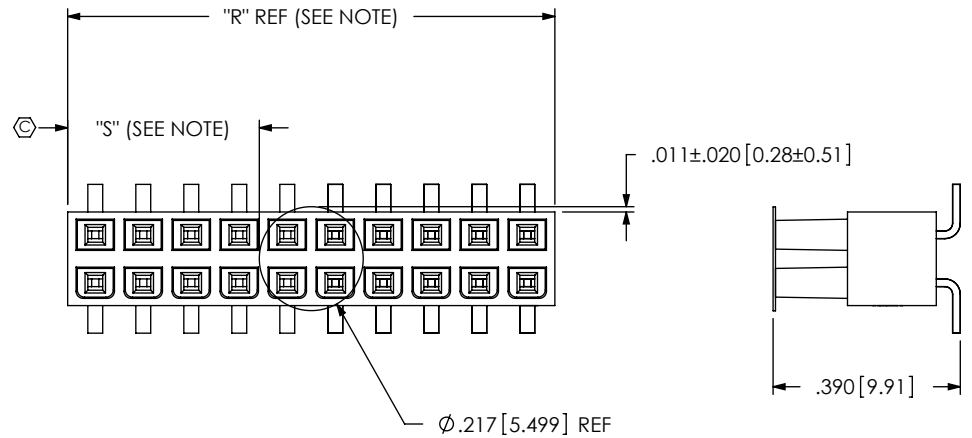

-PL: POLARIZED OPTION
 IPS1-110-01-X-D-VS-PL SHOWN

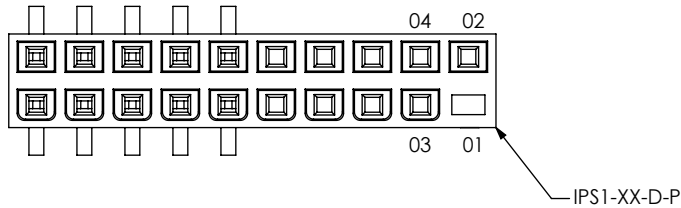

NOTE: "R" = USE MEASURED DIMENSION
 "S" = $(("R" - .2165[5.499]) / 2) \pm .020[.51]$

-LC: LOCKING CLIP OPTION
 IPS1-110-01-X-D-VS-LC-FL SHOWN

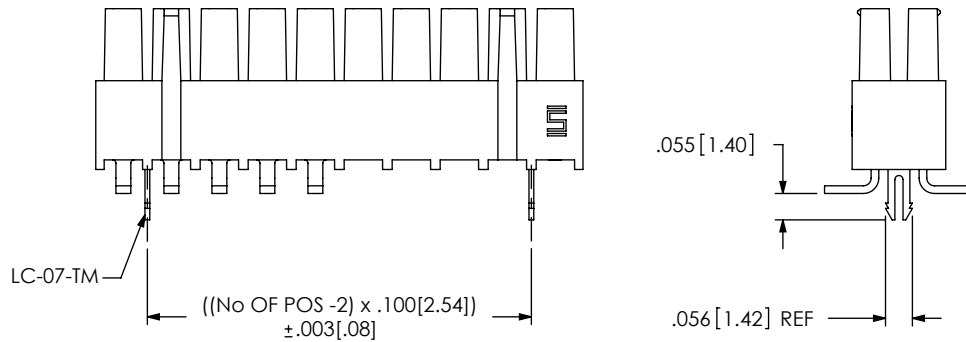

PROPRIETARY NOTE

THIS DOCUMENT CONTAINS INFORMATION CONFIDENTIAL AND PROPRIETARY TO SAMTEC, INC. AND SHALL NOT BE REPRODUCED OR TRANSFERRED TO OTHER DOCUMENTS OR DISCLOSED TO OTHERS OR USED FOR ANY PURPOSE OTHER THAN THAT WHICH IT WAS OBTAINED WITHOUT THE EXPRESSED WRITTEN CONSENT OF SAMTEC, INC.

DO NOT SCALE DRAWING

SHEET SCALE: 2.5:1



520 PARK EAST BLVD, NEW ALBANY, IN 47150
 PHONE: 812-944-6733 FAX: 812-948-5047
 e-Mail: info@SAMTEC.com code 55322

DESCRIPTION:
 .100 DOUBLE ROW SHROUDED SOCKET ASSEMBLY

DWG. NO.
IPS1-1XX-XX-XX-D-VS-XX-XX

BY: DEAN P 10-30-2002 SHEET 2 OF 2