

A PERFECT ALLIANCE.

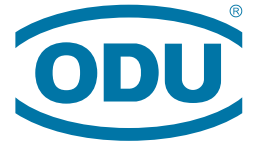

ODU MINI-SNAP[®]

Miniature circular connectors
with Push-Pull locking.

SERIES F



ODU MINI-SNAP[®] F

ODU MINI-SNAP[®] L / K / B

ODU AMC[®]

ODU MEDI-SNAP[®]

ODU MINI-SNAP[®] PC

ODU MINI-SNAP® F

FEATURES

- Quick and easy mating and locking
- Quick and easy demating
- Blind mating and demating in difficult-to-reach places
- Low space requirements on the receptacles
- Definite and secure locking conditions
- Low power requirement
- Suitable for use with robots
- Easy cleaning of the connector plug housing possible

APPLICATIONS

- Medical
- Industrial
- Test and measurement
- Military and security
- Energy
- eMobility



All shown connectors are according to IEC 61984:2008 (VDE 0627:2009); connectors without breaking capacity (COC).

ODU MINI-SNAP is UL-listed under file E110586, fulfils the demands of RoHS (2011/65/EU) and has a licence in accordance to VDE (Reg.-No. 40004941). MIL-specification: Tests carried out (see page [86](#)).

All dimensions are in mm.

Some figures are for illustrative purposes only. Subject to change without notice. Errors and omissions excepted. We reserve the right to change our products and their technical specifications at any time in the interest of technical improvement. This publication supersedes all prior publications.

This publication is also available as a PDF file that can be downloaded from www.odu-usa.com

Issue: 2018-05

Data transmission protocols

These ODU specific connectors can transmit common data transmission protocols such as CAT 5 or Ethernet, but they are not CAT- or Ethernet-standard connectors.

TABLE OF CONTENTS

Clickable page numbers

THE ODU CORPORATE GROUP	<u>4</u>
PRODUCT INFORMATION	<u>11</u>
Push-Pull connector series at a glance	<u>12</u>
Specific attributes of series F	<u>13</u>
Functional principle of the Push-Pull locking	<u>14</u>
Facts & Figures	<u>15</u>
CONFIGURATION GUIDELINE	<u>17</u>
Correct configuring – step by step	<u>19</u>
ODU MINI-SNAP® SERIES F	<u>23</u>
Summary ODU MINI-SNAP series F	<u>24</u>
The FP locking principle	<u>26</u>
Styles	<u>28</u>
Keyings	<u>42</u>
Contact inserts and PCB layouts	<u>44</u>
Cable collet system	<u>59</u>
Accessories	<u>61</u>
TOOLS, CRIMP INFORMATION, PROCESSING INSTRUCTIONS, ACCESSORIES	<u>71</u>
Crimping tools / assembly tools	<u>72</u>
Spanner wrench	<u>74</u>
Nutdriver for slotted mounting nut	<u>74</u>
Removal tools for crimp-clip-contacts	<u>75</u>
TECHNICAL INFORMATION	<u>77</u>
International protection classes acc. IEC 60529:2013 (VDE 0470-1:2014)	<u>78</u>
Principle of watertightness	<u>79</u>
Housing materials and insulator materials	<u>80</u>
Termination technologies	<u>81</u>
Conversions / AWG	<u>82</u>
Current load of turned contacts	<u>83</u>
Operating voltage	<u>84</u>
Electro magnetic compatibility (EMC)	<u>85</u>
Autoclaving	<u>86</u>
Test standard	<u>86</u>
Technical terms	<u>87</u>

A PERFECT ALLIANCE.

CREATING CONNECTIONS, BUILDING ALLIANCES, COLLABORATING INTO THE FUTURE: WHETHER TWO TECHNICAL COMPONENTS COME TOGETHER TO FORM A UNIT OR PEOPLE COME TOGETHER TO STRIVE FOR GREAT RESULTS – THE KEY IS TO ASPIRE IN ACHIEVING SUPERB RESULTS. THIS GOAL DRIVES OUR WORK. **PERFECT CONNECTIONS THAT INSPIRE AND DELIVER ON THE PROMISES.**





A PERFECT ALLIANCE.

ODU WORLDWIDE

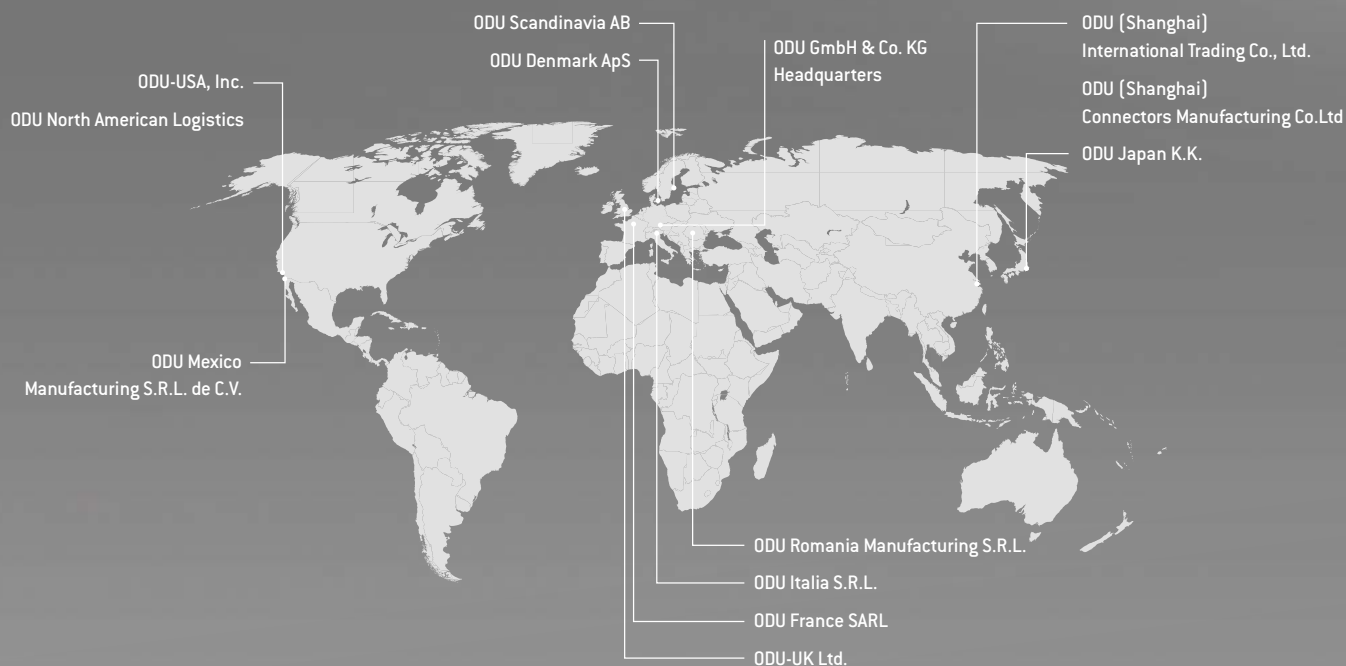

ODU GROUP OVERVIEW

- More than 75 years of experience in connector technology
- A turnover of 170 million Euro
- Over 1,900 employees worldwide
- 9 sales subsidiaries in China, Denmark, France, Germany, Italy, Japan, Sweden, the UK and the US as well as 5 production and logistics sites
- All technologies under one roof: Design and development, machine tool and special machine construction, injection, stamping, turning, surface technology, assembly and cable assembly

As of February 2018

CERTIFIED QUALITY

- DIN EN ISO 9001
- IATF 16949
- DIN EN ISO 14001
- ISO 13485
- Wide range of UL, CSA, VG and DVA licenses
- UL certified cable assembly

For a complete list of our certifications, please visit our website.

INGENIOUS IDEAS PERFECT SOLUTIONS

ODU'S PRODUCT PORTFOLIO.



COMPACT MODULAR CONNECTOR SOLUTIONS

- Application-specific hybrid interface
- For manual mating and automatic docking
- The highest packing density
- Flexible modular construction
- Multitude of data transmission modules
- Variety of locking options available
- For the transmission of signals, power, high current, high voltage, coax, high-speed data, fiber optics and other media such as air or fluid.
- Mating cycles scalable as required from 10,000 to over 100,000 (1 million)



PUSH-PULL CIRCULAR CONNECTORS

- Circular connector series in robust metal or plastic housing
- Contacts for soldering, crimping and PCB termination
- Optional selectable Push-Pull locking ensuring a secure connection at all times as well as easy to release Break-Away function
- 2 up to 55 contacts
- IP 50 to IP 69
- Autoclavable for medical applications
- Hybrid inserts for combined transmission



ELECTRICAL CONTACTS

- Versatile connector technologies
- Outstanding reliability, lifetime and durability
- Up to 1 million mating cycles
- Current-carrying capacity of up to 2,400 amperes and more
- Rugged contact systems, suitable even for harsh environments
- Economical solutions for automatic processing



A PERFECT ALLIANCE.

+ Versatile connector solutions for transmission of power, signals, data, or media – ODU never fails to offer the right interface when quality and absolute reliability are the top priorities.

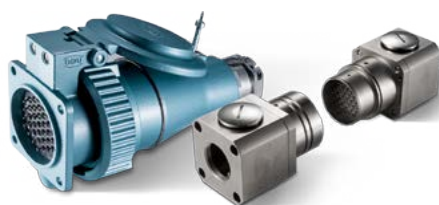

HEAVY-DUTY & DOCKING AND ROBOTIC CONNECTOR SOLUTIONS

- Extremely durable even under extreme /harsh environments
- Interference-free and secure connection, even under vibration
- Up to 500 A (higher currents upon request)
- High contact security due to the springwire technology
- High pin density due to a minimum contact diameter
- Low contact resistance



APPLICATION AND CUSTOMER-SPECIFIC SOLUTIONS

- Contacts, connectors and assemblies for the highest technical requirements as well as special applications
- First-class implementation expertise
- High level of vertical manufacturing – all competences and key technologies under one roof
- Expert advice based on mutual partnership
- Fast development and production



CABLE ASSEMBLY

- Complete systems from a single source based on years of assembly expertise
- State-of-the-art production facilities with 100% end testing, high-voltage testing, component testing and pressure testing up to 100 bar
- Cleanroom production
- Hot-melt and high-pressure injection molding
- Customer-specific labeling
- Rapid prototyping of samples

MORE THAN A CONNECTION

OUR KNOW-HOW FOR YOUR SUCCESS.

All shown connectors are according to DIN EN 61984:2009 connectors without breaking capacity (COC)!

General tolerances to DIN ISO 2768-mK		Tolerance to DIN ISO 8015		name		designation	
2013	date	2013	date	name	designation	name	designation
prep.	11.06.			Unterblum	Break-A		
app.							
norm.							

HIGH PERFORMANCE CONNECTOR TECHNOLOGY FOR DEMANDING KEY MARKETS

Customers rely on ODU technology wherever first-class, high-performance connector solutions are required. All our skills go into our products to ensure your success. In addition to the top quality, reliable stability and maximum flexibility in customer-specific requirements, our products also stand for dynamics, reliability, safety, precision, efficiency and sustainability. And they guarantee unrestricted functionality for the final product due to our high quality connectors. ODU – A PERFECT ALLIANCE.

APPLICATION-SPECIFIC SOLUTIONS

Demands that can't be pigeon-holed call for creative specialists who think outside the box. ODU offers the type of expertise that focuses solely on the specific requirements of our customers. For every development order we get, we not only perform a thorough check to make sure it's feasible, we intensively incorporate our customers in the ongoing design process. This guarantees an impressive, custom-fit final result. Our solutions are frequently based on the modifications of our products, especially for the ODU MINI-SNAP and ODU-MAC connectors.

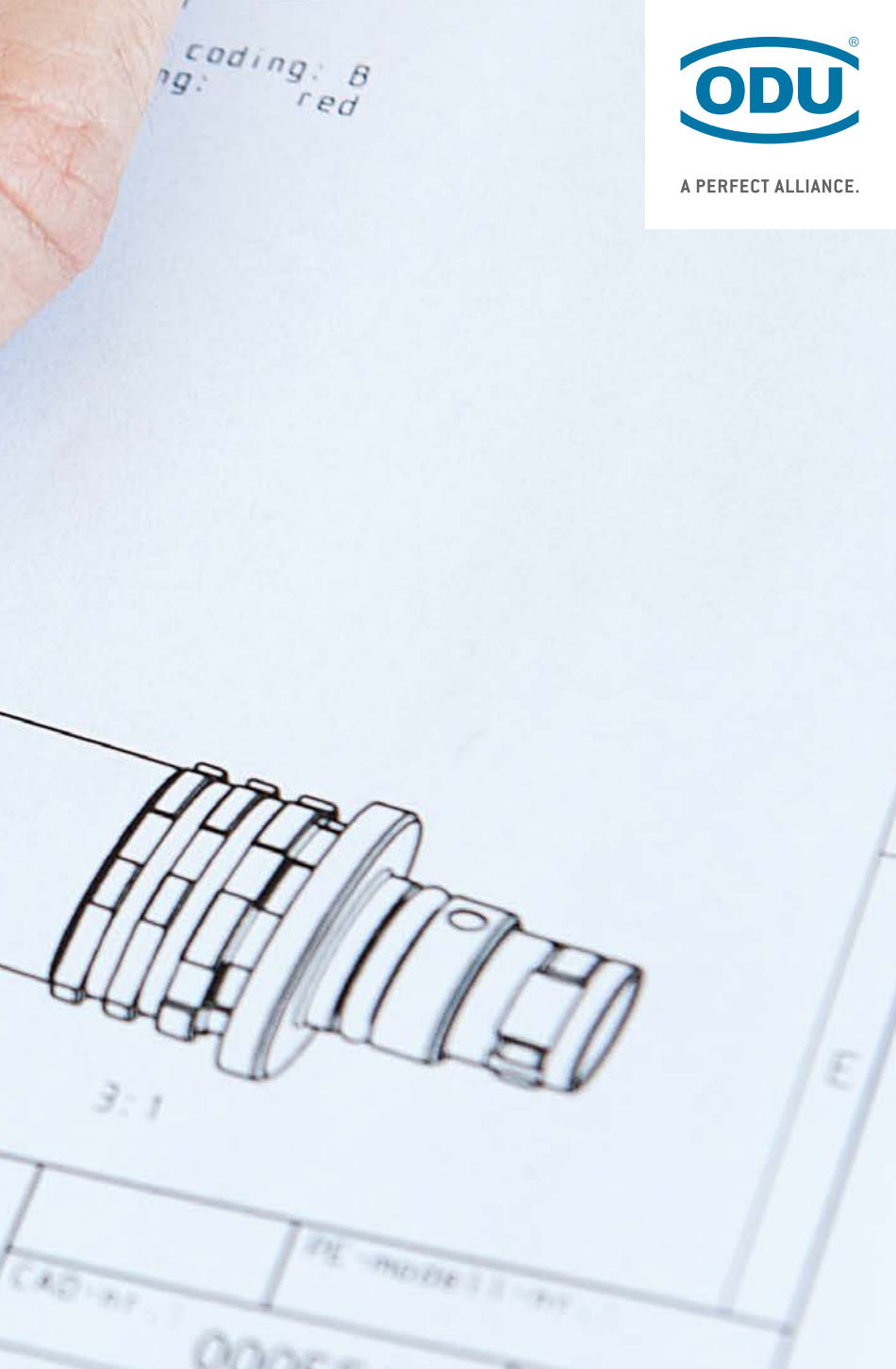

A PERFECT ALLIANCE.

MEDICAL

TEST AND MEASUREMENT

MILITARY AND SECURITY

INDUSTRIAL

ENERGY

EMOBILITY

HIGH LEVEL OF VERTICAL INTEGRATION

ODU combines all the competences and key technologies for the connector manufacturing. These include design and development, machine tool and special machine construction, injection, stamping, turning, surface technology, assembly and cable assembly and our own test laboratory.

INDIVIDUAL CABLE ASSEMBLY

Our production skills together with our cutting edge production facilities from Europe, China and the USA enable us to deliver to our customers locally tested assemblies and also global ones.



ODU MINI-SNAP®



PRODUCT INFORMATION

Push-Pull connector series at a glance	12
Specific attributes of the series F	13
Functional principle of the Push-Pull locking	14
Facts & Figures	15

THE COMPLETE SERIES OF ODU PUSH-PULL CONNECTORS AT A GLANCE

	Keying	Size	No. of possible mechanical keyings	Plug diameter in mm	Max. cable diameter in mm	Number of max. contacts	Solder	Crimp	PCB	International protection class A ¹	International protection class B ²
	Half-shell	0	3	9.4	5.0	09	•	•	•	up to IP 68	up to IP 68
		1		12	7.5	14					
		1.5		13	7.5	19					
		2		15	9.5	19					
		3		18	11.5	27					

FURTHER PRODUCTS OF THE ODU PUSH-PULL CONNECTOR SERIES:



- Versatile keying possibilities – in terms of colour and mechanical
- Low weight
- 2 to 26 contacts
- IP 50, IP 64 and IP 67
- Shielded version (BG 2) available
- Simplest assembly
- Autoclaveable / sterilisable model

- Keying over half-shell
- 2 to 27 contacts
- Low weight
- IP 50 and IP 67
- 3 sizes
- Plastic connector plug housing

- Keying over pin and groove
- 2 to 40 contacts
- 6 sizes
- IP 50 and IP 68
- Contacts for solder, crimp and PCB termination

- Keying over insulator
- 2 to 10 contacts / mixed inserts
- 3 sizes
- IP 50 and IP 68 with same outer diameter possible
- Contacts for solder, crimp and PCB termination

- Push-Pull and Break-Away version
- 3 to 55 contacts
- 6 sizes
- Watertight – IP 68
- Easy-Clean and High-Density version
- Tested acc. MIL
- Low weight (aluminium connector plug housing)

¹ International protection class in mated condition. ² International protection class in unmated condition to the end device.

CIRCULAR CONNECTORS WITH PUSH-PULL LOCKING IN METAL CONNECTOR PLUG HOUSING



ODU MINI-SNAP is the ideal self-locking circular connector for a wide range of applications. Whether used for transmitting power, signals, data or other media, this circular connector in its robust metal connector plug housing impresses customers with its exceptional quality, high reliability and ideal handling characteristics.

The Push-Pull principle reliably ensures that the connector will not come loose during application in practice: Once plugged in, the ODU MINI-SNAP locks itself into the receptacle automatically. It cannot be separated by pulling on the cable. Instead, the connector can easily be separated from the receptacle by pulling on the outer housing.

The ODU MINI-SNAP is available in a wide range of sizes and models. In addition, you can choose between three base codings.

VERSATILE CONFIGURATION OPTIONS

There are 5 sizes, 3 termination types and a great variety of various contact inserts to choose from.

THE LOCKING PRINCIPLE FOR ODU SERIES F

Push-Pull locking systems have a **highly user-friendly locking mechanism**. When the connector is mated with the receptacle, the connector's locking fingers (1) will lock into place in the receptacle and form a **dependable connection** between both parts. It **cannot be separated** by pulling on the connector's cable (2). Instead, the connector can easily be separated from the receptacle **by pulling on the outer housing (3)**. Push-pull connectors from ODU are available in 5 different standard sizes with diameters from 9.4 mm to 18 mm.

Connector in **unmated** condition.

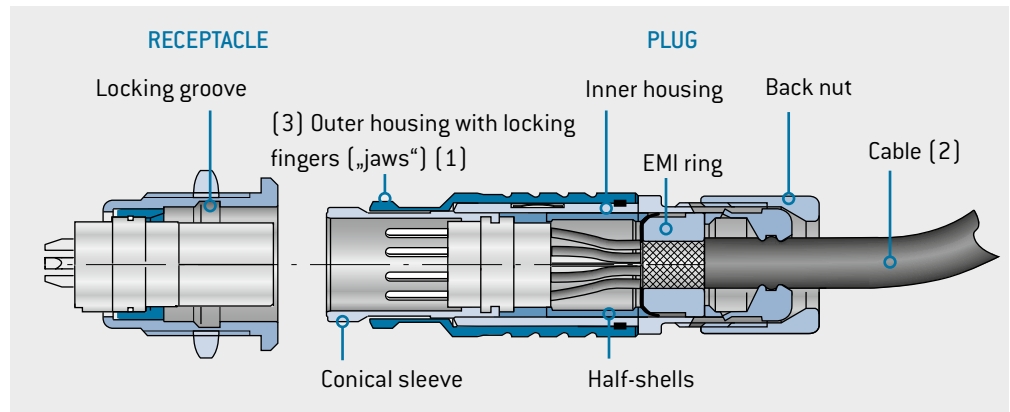

Pulling on the cable or back nut causes the locking fingers to grip harder into the locking groove in the receptacle. This prevents the connector from being disconnected.

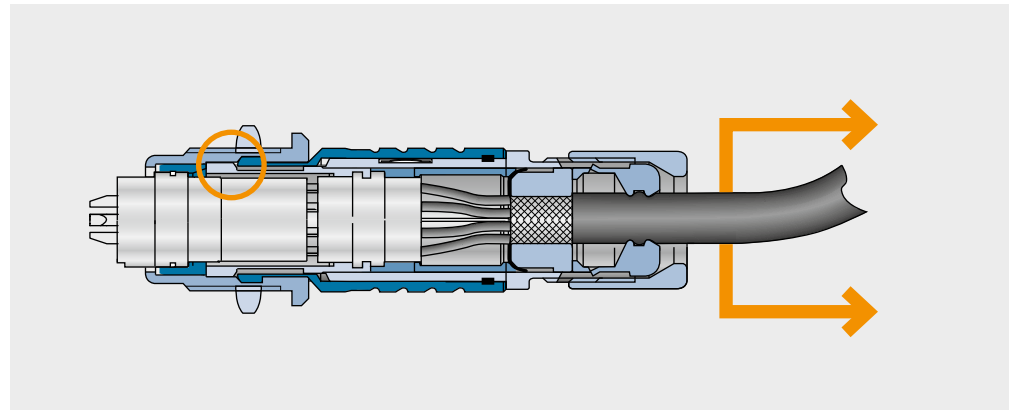

But pulling on the outer housing will cause the fingers to emerge from the locking groove, making it easy to disconnect the connector.

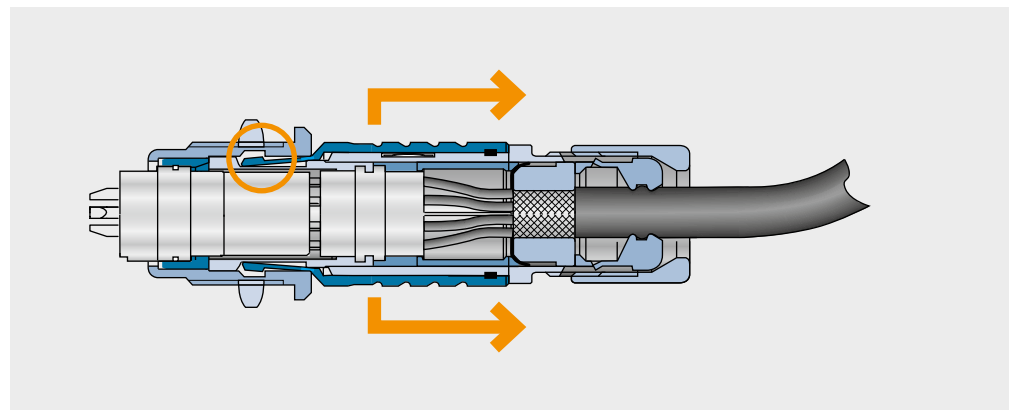

IMPORTANT ISSUES AT A GLANCE

VARIOUS SIZES

- Metal connector plug housing deliverable in 5 sizes
- Outer diameter 9.4 mm to 18 mm
- Number of contacts 2 to 27 contacts, mixed inserts
- Protection class IP 50 and IP 68 are deliverable

APPLICATIONS AND MATERIALS

The ODU MINI-SNAP uses PEEK insulator material as a standard feature. Other materials are available upon request. ODU MINI-SNAP connector plug housings are made of brass, nickel plated and then matt chrome plated. Nickel and black chrome plated connector plug housings are available upon request as special materials. The internal parts are made of nickel plated brass.

Thanks to its versatility and autoclavability, the ODU MINI-SNAP is used in a wide range of fields, such as medical, measurement and testing, military and security, industrial electronics and energy.

The temperature of ODU MINI-SNAP range under general conditions of use runs from $-40\text{ }^{\circ}\text{C}$ to $+120\text{ }^{\circ}\text{C}$, while autoclavable connectors can even be used at temperatures up to $+134\text{ }^{\circ}\text{C}$ [see page [86](#)].

TURNUED CONTACTS

Turned contacts are available in diameter 0.5 mm to 3.0 mm in the following termination types:

Solder, crimp and PCB

Mating cycles	> 5.000
Material	Brass
Plating	Ni and Au

TERMINATION TECHNOLOGIES

	Plug	Receptacle
Crimp termination ¹	•	•
Solder termination	•	•
PCB termination	•	•

¹ Crimp-clip-contacts available with diameter 0.7 mm, 0.9 mm and 1.3 mm.

STANDARD PIN CONTACTS

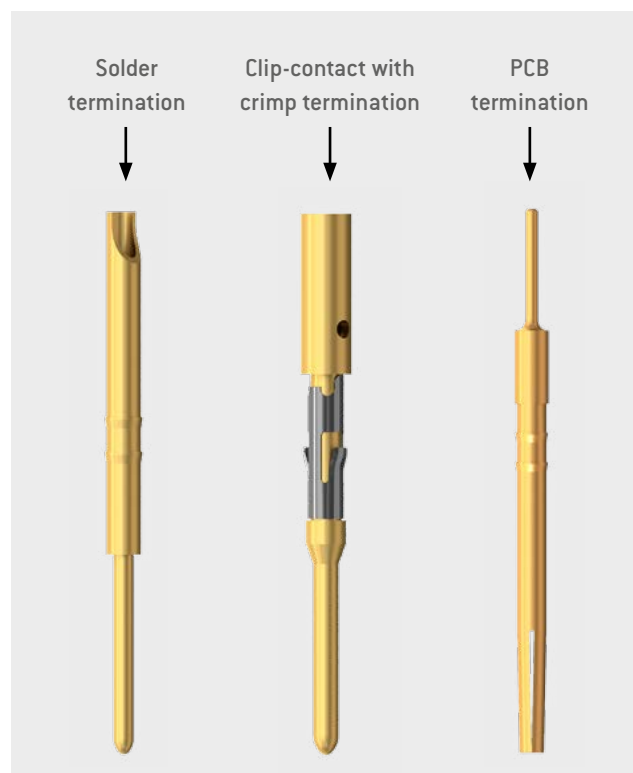

Information on diameters, terminal types and current-carrying capacity can be found after the inserts.



ODU MINI-SNAP®



CONFIGURATION

Correct configuring – step by step

BIT BY BIT TO THE PERFECT CONNECTION

ODU offers you high-quality connectors and comprehensive service for the complete assembly. From connectors to watertight potting, we provide the complete system from a single source.



SAMPLE CONFIGURATION STEP BY STEP

The perfect product for you in just a few steps. These step-by-step instructions show you how to configure your own individual product with the ODU part number key based on a sample configuration.



Connector in style 2 / size 2 / series F / keying 1 / connector plug housing Ms matt chrome plated / insulator PEEK / 16 contacts / pin (solder) Au / termination cross-section AWG 22 / cable diameter 6,5 – 7 mm / back nut for silicone cable bend relief (silicone cable bend relief has to be ordered separately)

STEP 1: SERIES (SEE POSITION 4)

1	2	3	4	5	6	7	8	9	10	11	12	13	14	15	16	17	18	19
			F		C	-	P							-			0	

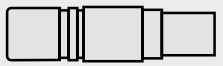
←  SERIES F

STEP 2: TYPE/STYLE (SEE POSITIONS 1, 2 AND 19)

PAGE 28 – 41

1	2	3	4	5	6	7	8	9	10	11	12	13	14	15	16	17	18	19
S	2		F		C	-	P							-			0	S

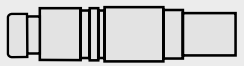
←  STYLE S 2 WITH BACK NUT FOR SILICONE CABLE BEND RELIEF

STEP 3: SIZE (SEE POSITION 3)

PAGE 28 – 41

1	2	3	4	5	6	7	8	9	10	11	12	13	14	15	16	17	18	19
S	2	2	F		C	-	P							-			0	S

←  SIZE 2

STEP 4: KEYING (SEE POSITION 5)

PAGE 42

1	2	3	4	5	6	7	8	9	10	11	12	13	14	15	16	17	18	19
S	2	2	F	1	C	-	P							-			0	S

←  KEYING 1

STEP 5: HOUSING MATERIAL (SEE POSITION 6)

PAGE 42

1	2	3	4	5	6	7	8	9	10	11	12	13	14	15	16	17	18	19
S	2	2	F	1	C	-	P							-			0	S

←  CR matt
SURFACE MATT CHROME (FURTHER ON REQUEST)

YOUR WAY TO AN INDIVIDUAL CONNECTION:

HOW TO CONFIGURE WITH THE PART NUMBER KEY

This shows you how ODU's part number key is composed. In the first part of the configuration, select the connector plug housing (such as style and size) of the connector. In the middle part of the part number key, you configure the contact insert and then the cable entry.

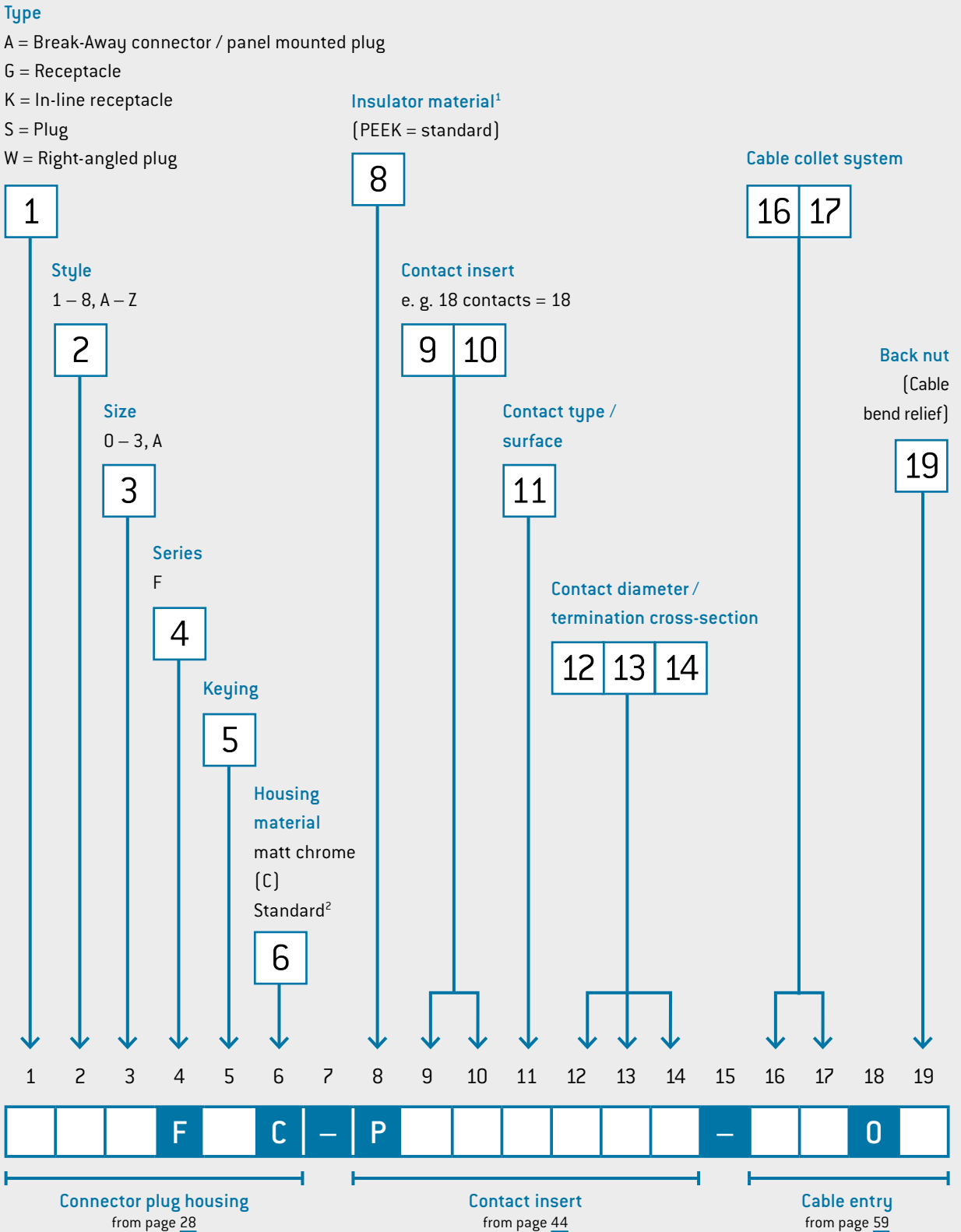

¹Other insulation materials on request. ²Black chrome plated on request.

STEP 6: INSULATOR MATERIAL (SEE POSITION 8)

1	2	3	4	5	6	7	8	9	10	11	12	13	14	15	16	17	18	19
S	2	2	F	1	C	-	P							-			0	S

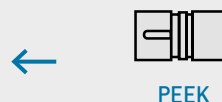

STEP 7: CONTACT INSERT (SEE POSITIONS 9 AND 10)

PAGE 44 – 55

1	2	3	4	5	6	7	8	9	10	11	12	13	14	15	16	17	18	19
S	2	2	F	1	C	-	P	1	6					-			0	S



STEP 8: CONTACT TYPE / SURFACE (SEE POSITION 11)

1	2	3	4	5	6	7	8	9	10	11	12	13	14	15	16	17	18	19
S	2	2	F	1	C	-	P	1	6	M				-			0	S



STEP 9: CONTACT DIAMETER (SEE POSITION 12)

1	2	3	4	5	6	7	8	9	10	11	12	13	14	15	16	17	18	19
S	2	2	F	1	C	-	P	1	6	M	F			-			0	S

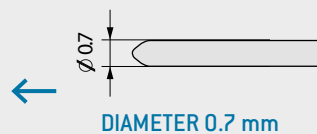

STEP 10: TERMINATION CROSS-SECTION (SEE POSITIONS 13 AND 14)

1	2	3	4	5	6	7	8	9	10	11	12	13	14	15	16	17	18	19
S	2	2	F	1	C	-	P	1	6	M	F	G	0	-			0	S

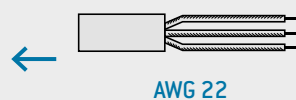

STEP 11: CABLE COLLET SYSTEM (SEE POSITIONS 16 AND 17)

1	2	3	4	5	6	7	8	9	10	11	12	13	14	15	16	17	18	19
S	2	2	F	1	C	-	P	1	6	M	F	G	0	-	7	0	0	S

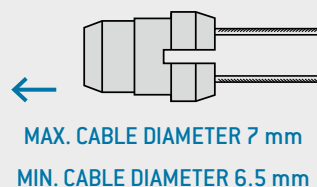



ODU MINI-SNAP®















ODU MINI-SNAP® SERIES F

Summary ODU MINI-SNAP series F	24
The FP locking principle	26
Styles	28
Keyings	42
Contact inserts and PCB layouts	44
Cable collet system	59
Accessories	61







SUMMARY ODU MINI-SNAP® SERIES F





The ODU MINI-SNAP series F with keying using a half-shell. These Push-Pull circular connectors can be configured in many different ways: a wide variety of sizes and termination types and contact inserts are available.

- Keying over half-shell
- 2 to 27 contacts / mixed inserts
- Up to 5 sizes and 3 termination types
- Choice of a multiplicity of connectors and receptacles
- Protection class IP 50 and protection class IP 68 available
- 5,000 mating cycles and more
- Contacts for solder, crimp and PCB termination

STRAIGHT PLUG		P. 28
IP 50		S 1
		S 2
IP 68		S 3
		S 4
BREAK-AWAY CONNECTOR		P. 30
IP 68		A 5
		A 6
IP 50		A 7
		A 8
PANEL MOUNTED PLUG		P. 32
IP 50		A A
IP 68		A D
SUPER SHORTY PUSH-PULL PLUG		P. 33
IP 68		S S
		A S

RIGHT-ANGLED PLUG		P. 34
IP 50		W 1
		W 2
IP 68		W 3
		W 4

RECEPTACLE		P. 38
IP 50		G 1
IP 68		G 2
		G 4
IP 50		G 5
IP 68		G 8
IP 50		G H
		G K

IN-LINE RECEPTACLE		P. 36
IP 50		K 1
		K 2
IP 68		K 3
		K 4

For assembly instructions please refer to our website: www.odu.de/downloads.

THE FP LOCKING SERIES F IN SECTIONAL VIEW

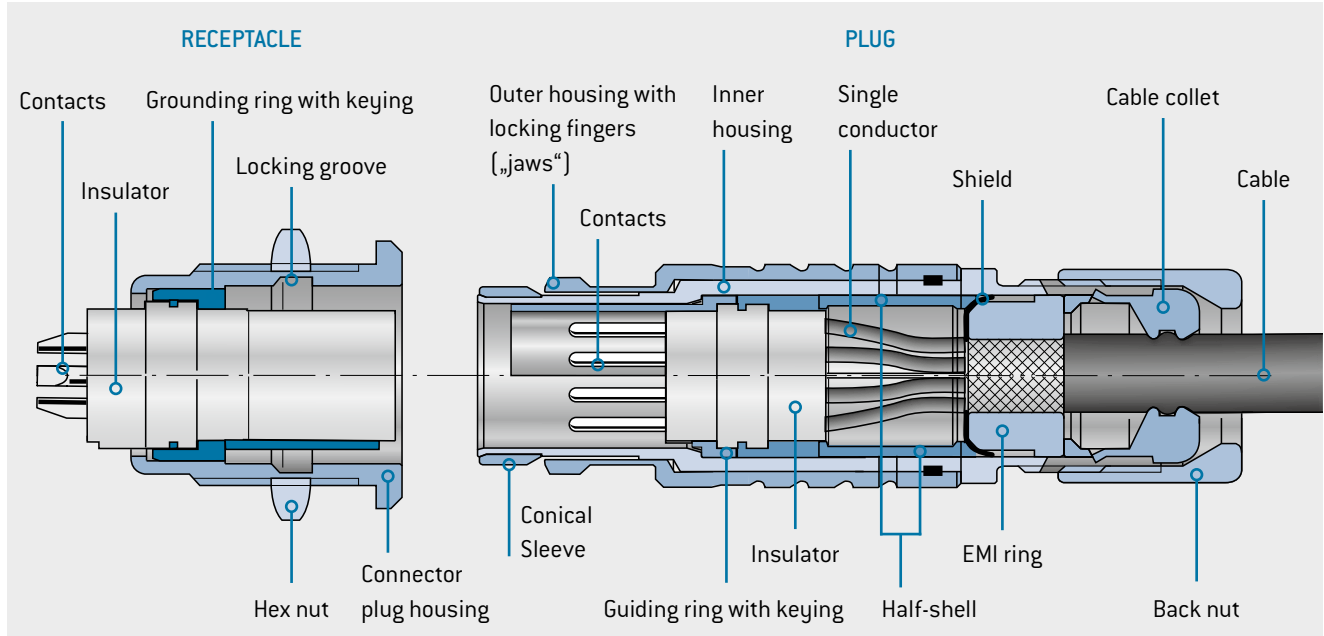

AVAILABLE SIZES

OUTER DIAMETER IN mm (PLUG)

Scale 1:1

Size

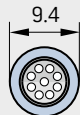

0

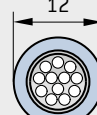

1

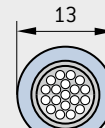

1.5 (A¹)

OUTER DIAMETER IN mm (PLUG)

Scale 1:1

Size

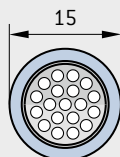

2

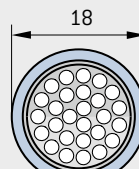

3

¹ Configuration in part number key for size 1.5.

FOR YOUR NOTES

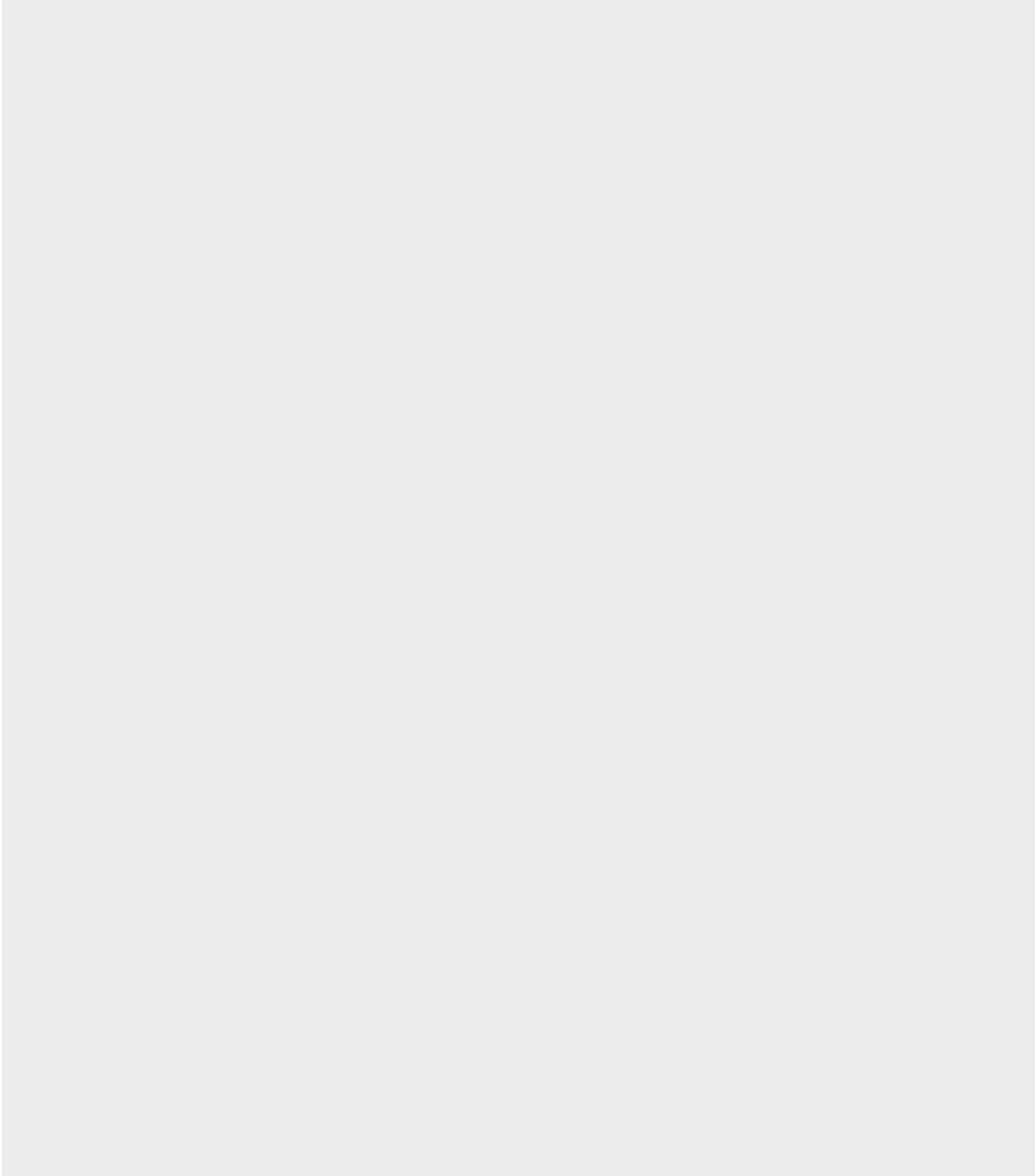

STRAIGHT PLUG



S 1 0 **STYLE: 1** **IP 50**

With standard back nut

S 2 S **STYLE: 2** **IP 50**

With back nut for cable bend relief¹

Size	L1 mm	L2 mm	D mm	SW A mm	S1 SW B mm	S2 SW B mm
0	≈ 37	≈ 27	9.4	8	7	7
1	≈ 46	≈ 35	12	10	10	10
A	≈ 48	≈ 38	13	11	12	12
2	≈ 50	≈ 38	15	13	12	13
3	≈ 59	≈ 44	18	16	15	15

TECHNICAL DATA

- Contact inserts from page 44
- Compatible with all following receptacles and in-line receptacles

0 1 A 2 3

1 2 3 4 5 6 7 8 9 10 11 12 13 14 15 16 17 18 19

F C - P - 0

¹ Please order cable bend reliefs separately, see page 65.

STRAIGHT PLUG



S 3 0 **STYLE: 3** IP 68

With standard back nut

S 4 S **STYLE: 4** IP 68

With back nut for cable bend relief¹

Size	L1 mm	L2 mm	D mm	SW A mm	S3 SW B mm	S4 SW B mm
0	≈ 40	≈ 30	9.4	8	7	7
1	≈ 49	≈ 38	12	10	10	10
A	≈ 50	≈ 40	13	11	12	12
2	≈ 53	≈ 41	15	13	12	13
3	≈ 61	≈ 46	18	16	15	15

TECHNICAL DATA

- Contact inserts from page 44
- Compatible with all following receptacles and in-line receptacles

0 1 A 2 3

1 2 3 4 5 6 7 8 9 10 11 12 13 14 15 16 17 18 19

F C - P - 0

¹ Please order cable bend reliefs separately, see page 65.

BREAK-AWAY CONNECTOR (WITHOUT LOCKING)



A 5 0 **STYLE: 5** **IP 68**

With standard back nut

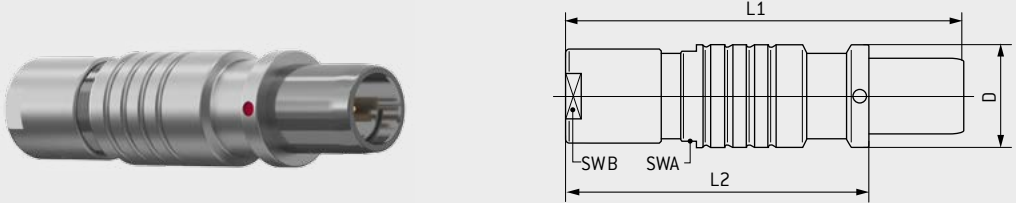

A 6 S **STYLE: 6** **IP 68**

With back nut for cable bend relief¹

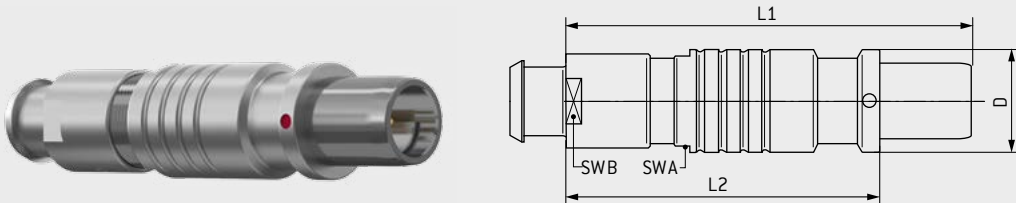

Size	L1 mm	L2 mm	D mm	SW A mm	A5 SW B mm	A6 SW B mm
1	≈ 49	≈ 38	12	10	10	10
1.5	≈ 50	≈ 40	13	11	12	12
3	≈ 61	≈ 46	18	16	15	15

TECHNICAL DATA

- Contact inserts from page 44
- Compatible with all following receptacles and in-line receptacles
- Plug can be separated by pulling on the cable

1
A
3

1 2 3 4 5 6 7 8 9 10 11 12 13 14 15 16 17 18 19

F C - P - O

¹ Please order cable bend reliefs separately, see page 65.

BREAK-AWAY CONNECTOR (WITHOUT LOCKING)

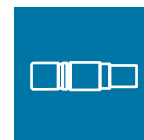

A 7 0 **STYLE: 7** **IP 50**

With standard back nut

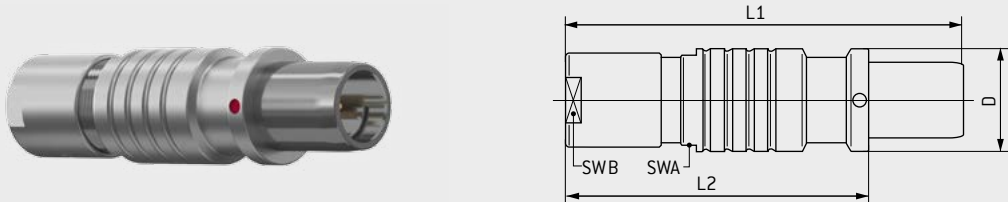

A 8 S **STYLE: 8** **IP 50**

With back nut for cable bend relief¹

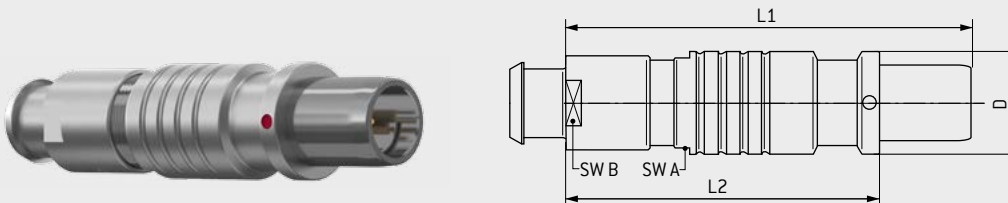

Size	L1 mm	L2 mm	D mm	SW A mm	A7 SW B mm	A8 SW B mm
0	≈ 37	≈ 27	9.4	8	7	7
1	≈ 46	≈ 35	12	10	10	10
2	≈ 50	≈ 38	15	13	12	13

TECHNICAL DATA

- Contact inserts from page 44
- Compatible with all following receptacles and in-line receptacles
- Plug can be separated by pulling on the cable

0
1
2

1 2 3 4 5 6 7 8 9 10 11 12 13 14 15 16 17 18 19

F C - P - 0

¹ Please order cable bend reliefs separately, see page 65.

PANEL MOUNTED PLUG



Suitable for creating a docking connection between 2 devices (e. g. on a charging station).

A A

STYLE: A

IP 50

With hex nut, without locking, installation from front of panel

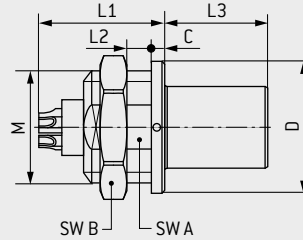

Panel cut-out

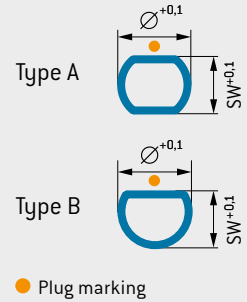

Size	L1 mm	L2 max. mm	L3 mm	C mm	D mm	SW A mm	SW B mm	M mm	Panel cut-out		
									SW mm	Ø mm	Type
0	≈ 12	≈ 4	10	1.5	10	8.2	11	9 × 0.5	8.3	9.1	A
1	≈ 15.5	≈ 4	10.8	1.5	14	11.1	14	12 × 1	11.2	12.1	B
2	≈ 17.5	≈ 3.4	12	2	18	14.1	17	15 × 1	14.2	15.1	B
3	≈ 17	≈ 5.5	15	1.2	22	15.2	19	16 × 1	15.3	16.1	B

TECHNICAL DATA

- Contact inserts from page 44
- PCB layouts see from page 45
- Compatible with all following receptacles and in-line receptacles
- IP 50 in reference to the tightness of the end device
- Anti-rotation feature

A D

STYLE: D

IP 68

With hex nut, without locking, installation from front of panel

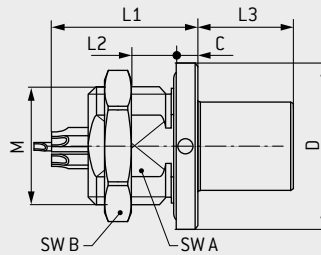

Panel cut-out

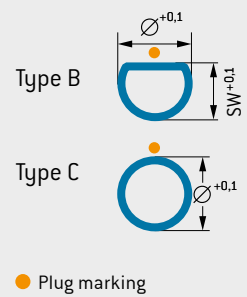

Size	L1 mm	L2 max. mm	L3 mm	C mm	D mm	SW A mm	SW B mm	M mm	Panel cut-out		
									SW mm	Ø mm	Type
0	≈ 14.5	≈ 4.5	10	3	13	–	11	9 × 0.5	–	9.1	C
1	≈ 18.5	≈ 6.5	10.8	2.5	17	11	14	12 × 1	11.1	12.1	B
2	≈ 20	≈ 7	12	3	22	15.2	19	16 × 1	15.3	16.1	B

TECHNICAL DATA

- Contact inserts from page 44
- PCB layouts see from page 45
- Compatible with all following receptacles and in-line receptacles
- IP 68 in reference to the tightness of the end device even in unmated condition
- Anti-rotation feature
- No crimp contacts possible

1 2 3 4 5 6 7 8 9 10 11 12 13 14 15 16 17 18 19

F C - P - 0 0

SUPER SHORTY PUSH-PULL PLUG



S S

STYLE: S

IP 68

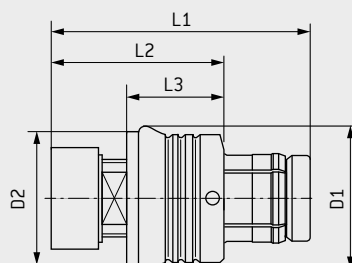

Size	L1 mm	L2 mm	L3 mm	D1 mm	D2 mm	Max. cable Ø mm
0	≈ 28	≈ 18	10.5	13	11.9	5
1	≈ 32.7	≈ 22	12.5	15	13.9	6.5
1.5	≈ 32.5	≈ 23	13	15.7	14.5	8.3
2	≈ 34.3	≈ 22.6	13	19	17.6	10
3	≈ 38.4	≈ 23.3	13.8	23.9	21.9	11.5

TECHNICAL DATA

- Contact inserts from page 44
- Compatible with all following receptacles and in-line receptacles
- Crimping of the cable shield causes strain relief
- Suitable for overmolded shield crimping

0	5	5
1	7	0
A	8	8
2	0	2
3	1	2

A S

STYLE: S

IP 68

Without locking

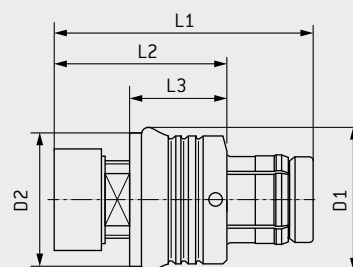

Size	L1 mm	L2 mm	L3 mm	D1 mm	D2 mm	Max. cable Ø mm
0	≈ 28	≈ 18	10.5	13	11.9	5
1	≈ 32.7	≈ 22	12.5	15	13.9	6.5
2	≈ 34.3	≈ 22.6	13	19	17.6	10

TECHNICAL DATA

- Contact inserts from page 44
- Compatible with all following receptacles and in-line receptacles
- Crimping of the cable shield causes strain relief
- Suitable for overmolded shield crimping

0	5	5
1	7	0
2	0	2

1 2 3 4 5 6 7 8 9 10 11 12 13 14 15 16 17 18 19

F C - P - O C

RIGHT-ANGLED PLUG



W 1 0 **STYLE: 1** **IP 50**

With standard back nut

W 2 S **STYLE: 2** **IP 50**

With back nut for cable bend relief¹

Size	L1 mm	L2 mm	L3 mm	C mm	D mm	SW A mm	W1 SW B mm	W2 SW B mm	SW C mm
0	33	23	≈ 25	10	9	9	7	7	8
1	37.3	26.5	≈ 28	12	11	11	10	10	10
A	1.5	39	≈ 31	14	13	12	12	12	11
2	41.6	29.5	≈ 34.5	16	14	14	12	13	13
3	50	35	≈ 41	18	17	16	15	15	16

TECHNICAL DATA

- Contact inserts from page 44
- Compatible with all following receptacles and in-line receptacles

0 1 A 2 3

1 2 3 4 5 6 7 8 9 10 11 12 13 14 15 16 17 18 19

F C - P - O

¹ Please order cable bend reliefs separately, see page 65.

RIGHT-ANGLED PLUG



W 3 0 **STYLE: 3** **IP 68**

With standard back nut

W 4 S **STYLE: 4** **IP 68**

With back nut for cable bend relief¹

Size	L1 mm	L2 mm	L3 mm	C mm	D mm	SW A mm	W3 SW B mm	W4 SW B mm	SW C mm
0	36	26	≈ 27	11.2	9	10	7	7	8
1	45.2	34.2	≈ 33	13	11	12	10	10	10
A	1.5	41.5	≈ 34.5	14.5	13	13	12	12	11
2	2	46.3	≈ 36	16	14	14	12	13	13
3	3	59.7	≈ 41	18	17	16	15	15	16

TECHNICAL DATA

- Contact inserts from page 44
- Compatible with all following receptacles and in-line receptacles

1 2 3 4 5 6 7 8 9 10 11 12 13 14 15 16 17 18 19

F C - P - O

¹ Please order cable bend reliefs separately, see page 65.

IN-LINE RECEPTACLE



Suitable for creating a cable-cable connection.

K 1

0

STYLE: 1

IP 50

With standard back nut

K 2

S

STYLE: 2

IP 50

With back nut for cable bend relief¹

Size	L1 mm	D mm	SW A mm	K1 SW B mm	K2 SW B mm
0	≈ 35	9.4	8	7	7
1	≈ 44	12	10	10	10
2	≈ 48	15	13	12	13
3	≈ 58	18	16	15	15

TECHNICAL DATA

- Contact inserts from page [44](#)

0

1

2

3

¹ Please order cable bend reliefs separately, see page [65](#).

IN-LINE RECEPTACLE

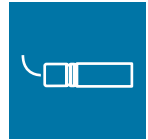

Suitable for creating a cable-cable connection.

K 3 0 **STYLE: 3** **IP 68**

With standard back nut

K 4 S **STYLE: 4** **IP 68**

With back nut for cable bend relief¹

Size	L1 mm	D mm	SW A mm	K3 SW B mm	K4 SW B mm
0	≈ 38	10	8	7	7
1	≈ 47	13	10	10	10
2	≈ 51	16	13	12	13

TECHNICAL DATA

- Contact inserts from page 44

0
1
2

1 2 3 4 5 6 7 8 9 10 11 12 13 14 15 16 17 18 19

F C - P - O

¹ Please order cable bend reliefs separately, see page 65.

RECEPTACLE



G 1

STYLE: 1 **IP 50**

Installation from front of panel

Size	L1 ¹ mm	L2 max mm	L3 ² mm	M mm	D mm	SW A mm	SW B mm	C mm	Panel cut-out		
									SW mm	Ø mm	Type
0	≈ 20	≈ 9	14.5	9 × 0.5	10	8.2	11	1.5	8.3	9.1	A
1	≈ 24	≈ 8	16.5	12 × 1	14	10	14	1.5	10.1	12.1	A
A	≈ 25	≈ 8	15.5	14 × 1	16	12	17	2	12.1	14.1	D
2	≈ 27	≈ 10	18.5	15 × 1	18	14.1	17	2	14.2	15.1	B
3	≈ 30.5	≈ 13	22.5	18 × 1	22	16.5	22	2	16.6	18.1	A

Panel cut-out

● Plug marking

- TECHNICAL DATA**
- Contact inserts from page 44
 - PCB layouts see from page 45
 - IP 50 in reference to the tightness of the end device
 - Anti-rotation feature
 - Only straight PCB contact possible

G 2

STYLE: 2 **IP 68⁴**

Installation from front of panel

Size	L1 ¹ mm	L2 ³ mm	L3 ² mm	M mm	D1 mm	D2 mm	SW A mm	SW B mm	C mm	Panel cut-out	
										Ø mm	Type
0	≈ 22.5	≈ 8	18.5	9 × 0.5	14.5	10	11	11	3	10.1	C
1	≈ 27	≈ 9	22.5	14 × 1	18	14	14	17	3	14.1	C
A	≈ 27	≈ 8	21.6	14 × 1	19	14	15	17	3.5	14.1	C
2	≈ 29.5	≈ 9	23	16 × 1	22	16	17	19	4	16.1	C
3	≈ 32	≈ 12	26.5	20 × 1	26	20	24	25	4	20.1	C

Panel cut-out

● Plug marking

- TECHNICAL DATA**
- Contact inserts from page 44
 - PCB layouts see from page 45
 - IP 68 in reference to the tightness of the end device even in unmated condition
 - Distance ring for wall-thickness adjustment see accessories see page 62
 - No crimp contacts possible
 - Only straight PCB contact possible

1 2 3 4 5 6 7 8 9 10 11 12 13 14 15 16 17 18 19

F C - P - 0 0

¹ L1 = maximum length including contact insert. ² L3 = Length of connector plug housing.
³ Minimum wall-thickness without use of distance rings. ⁴ Tight, grouted receptacle see page 79, 3. Case.

RECEPTACLE



G 4

STYLE: 4

IP 68³

Installation from front of panel, with slight installation depth

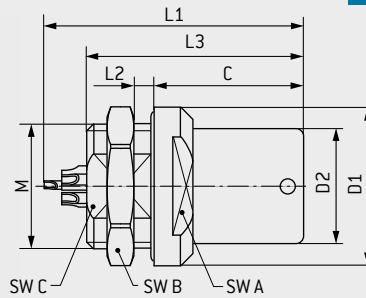

Panel cut-out

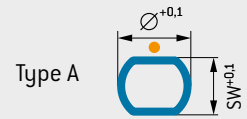

● Plug marking

Size	L1 ¹ mm	L2 max. mm	L3 ² mm	M mm	D1 mm	D2 mm	SW A mm	SW B mm	SW C mm	C mm	Panel cut-out		
											SW mm	Ø mm	Type
0	≈ 22.5	≈ 4	17.5	9 × 0.5	14.5	10.5	12	11	8.2	11	8.3	9.1	A
1	≈ 27	≈ 4	22.5	14 × 1	18	13	14	17	12	15.5	12.1	14.1	A
A	≈ 28	≈ 5	21.6	14 × 1	19	13.5	15	17	12	13.6	12.1	14.1	A
2	≈ 32	≈ 4.5	23	16 × 1	21	16	17	19	14	15.5	14.1	16.1	A

TECHNICAL DATA

- Contact inserts from page 44
- PCB layouts see from page 45
- IP 68 in reference to the tightness of the end device even in unmated condition
- Anti-rotation feature
- No crimp contacts possible
- Only straight PCB contact possible

1 2 3 4 5 6 7 8 9 10 11 12 13 14 15 16 17 18 19

F C - P - 0 0

¹ L1 = maximum length including contact insert. ² L3 = Length of connector plug housing.
³ Tight, grouted receptacle see page 79, 3. Case.

RECEPTACLE



G 5

STYLE: 5

IP 50

With continuous thread, installation from front or rear of panel with optimal distance adjustment

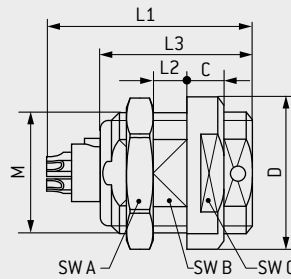

Panel cut-out

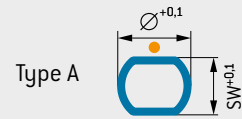

● Plug marking

Size	L1 ¹ mm	L2 max. mm	L3 ² mm	M mm	D mm	SW A mm	SW B mm	SW C mm	C mm	Panel cut-out		Type
										SW mm	∅ mm	
0	≈ 20	≈ 8	14.5	9 × 0.5	11.5	11	8	10	2.5	8.1	9.1	A
1	≈ 24	≈ 8	16.5	12 × 1	15	14	10	13	4	10.1	12.1	A
A	≈ 25	≈ 7	15.5	14 × 1	19	17	12	17	3	12.1	14.1	A
2	≈ 27	≈ 10	18.5	15 × 1	20	17	13.5	17	4	13.6	15.1	A
3	≈ 30.5	≈ 12	22.5	18 × 1	23	22	16.5	20	5	16.6	18.1	A

TECHNICAL DATA

- Contact inserts from page 44
- PCB layouts see from page 45
- IP 50 in reference to the tightness of the end device
- Anti-rotation feature
- Right-angled PCB contact possible, see page 58

G 8

STYLE: 8

IP 68³

Installation from rear of panel, with designer nut

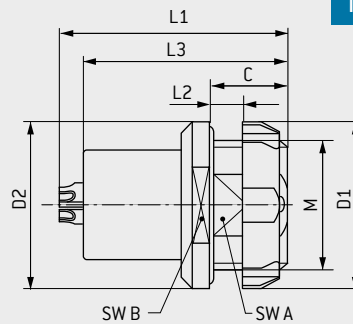

Panel cut-out

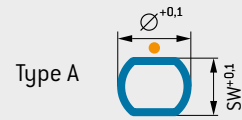

● Plug marking

Size	L1 ¹ mm	L2 max. mm	L3 ² mm	M mm	D1 mm	D2 mm	SW A mm	SW B mm	C mm	Panel cut-out		Type
										SW mm	∅ mm	
0	≈ 22.5	≈ 3.5	17	9 × 0.5	12	14	8.2	11	6.5	8.3	9.1	D
1	≈ 27.5	≈ 4	21	14 × 1	18	18	12	–	8	12.1	14.1	A
A	≈ 27	≈ 3	19.5	14 × 1	18	19	12	–	7	12.1	14.1	D
2	≈ 29.5	≈ 3	23	16 × 1	22	21	14.3	–	8	14.4	16.1	A
3	≈ 32	≈ 6	26.5	20 × 1	25	26	18	–	11	18.1	20.1	A

TECHNICAL DATA

- Contact inserts from page 44
- PCB layouts see from page 45
- IP 68 in reference to the tightness of the end device even in unmated condition
- Anti-rotation feature
- No crimp contacts possible
- Assembly wrench page 74
- Right-angled PCB contact possible, see page 58

1 2 3 4 5 6 7 8 9 10 11 12 13 14 15 16 17 18 19

F C - P - 0 0

¹ L1 = maximum length including contact insert. ² L3 = Length of connector plug housing.

RECEPTACLE



G H

STYLE: H

IP 50

Projecting receptacle with slight installation depth, installation from front of panel with optimal distance adjustment

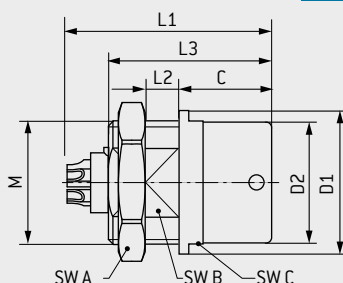

Panel cut-out

Type A

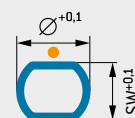

● Plug marking

Size	L1 ¹ mm	L2 max. mm	L3 ² mm	M mm	D1 mm	D2 mm	SW A mm	SW B mm	SW C mm	C mm	Panel cut-out		
											SW mm	∅ mm	Type
0	≈ 20	≈ 3	16	9 × 0.5	11	9	11	8.2	–	11	8.3	9.1	A
1	≈ 24	≈ 4.5	17.5	12 × 1	14	11.7	14	10	12	10	10.1	12.1	A
A	≈ 26	≈ 5	17	14 × 1	18	13.5	17	12	15	10	12.1	14.1	A
2	≈ 27	≈ 5.5	19.5	16 × 1	19	16	19	13.5	17	11	13.6	16.1	A

TECHNICAL DATA

- Contact inserts from page 44
- PCB layouts see from page 45
- IP 50 in reference to the tightness of the end device
- Anti-rotation feature
- Only straight PCB contact possible

G K

STYLE: K

IP 50

Installation from rear of panel, with slight installation depth

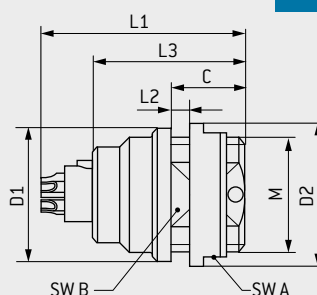

Panel cut-out

Type A

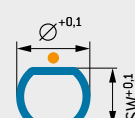

Type B

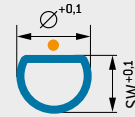

● Plug marking

Size	L1 ¹ mm	L2 max. mm	L3 ² mm	M mm	D1 mm	D2 mm	SW A mm	SW B mm	C mm	Panel cut-out		
										SW mm	∅ mm	Type
0	≈ 20	≈ 3	14.5	9 × 0.5	11	11.5	10	8	6.5	8.1	9.1	A
1	≈ 24	≈ 4	16.5	12 × 1	14	15	13	11	8	11.1	12.1	B
2	≈ 27	≈ 5	18.5	15 × 1	19	20	17	14	9	14.1	15.1	B
3	≈ 30.5	≈ 12	22.5	18 × 1	22	23	20	17.2	17	17.3	18.1	B

TECHNICAL DATA

- Contact inserts from page 44
- PCB layouts see from page 45
- IP 50 in reference to the tightness of the end device
- Anti-rotation feature
- Right-angled PCB contact possible, see page 58

1 2 3 4 5 6 7 8 9 10 11 12 13 14 15 16 17 18 19

F C - P - 0 0

¹ L1 = maximum length including contact insert. ² L3 = Length of connector plug housing.

KEYINGS

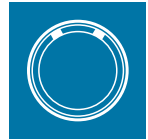

	Receptacle mating side	Plug mating side	Size				
			0	1	1.5	2	3
1			•	•	•	•	•
			•	•			
2					•	•	•
			o				
3				o			
					o	o	o

Housing material – surface	
C	Standard Cu alloy / matt chrome plated
S	On request Cu alloy / black chrome plated

Special materials and surfaces on request.

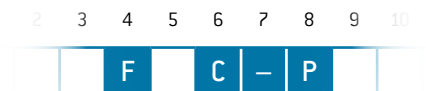

• Standard
o On request

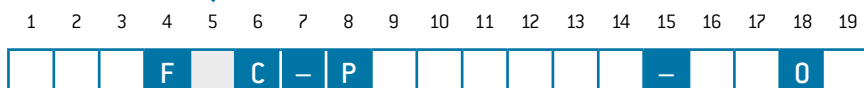
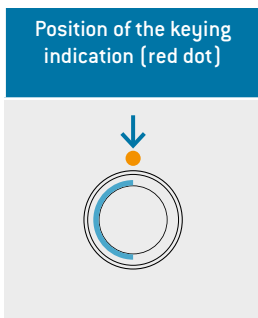

FOR YOUR NOTES

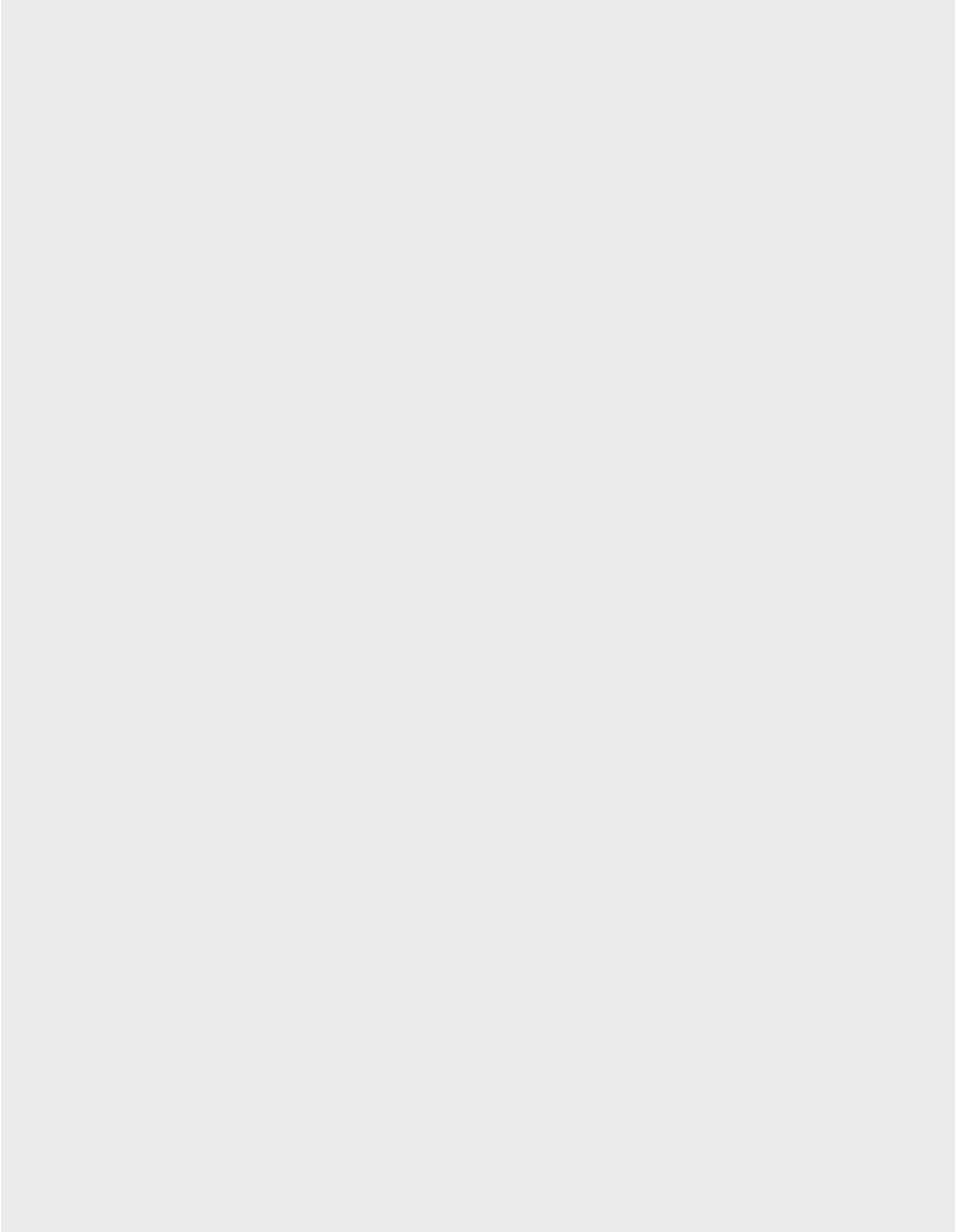

CONTACT INSERTS (SIZE 0)



Number of contacts	Contact type			Part number key			Contact diameter mm	Single contact nominal current ¹ A	Clearance and creepage distance		Test voltage ² kVeff	Nominal voltage ⁵ kVrms	Termination diameter mm	Termination cross section		View on termination area							
	Termination	Socket	Pin						Contact to contact mm	Contact to housing mm				AWG	mm ²	Pin piece	Socket piece						
0	2	Solder	L	M	J	G	0.9	7.5	1.0	0.8	1.500	0.500	0.85	22	0.38								
		PCB ⁴	Q	R	J	O			O							1.3		0.7	–	–			
0	3	Solder	L	M	J	G	0.9	7.5	0.6	0.9	1.200	0.400	0.85	22	0.38								
		PCB ⁴	Q	R	J	O			O							0.9	0.8	0.7	–	–			
0	4	Solder	L	M	F	G	0.7	7.5	0.6	0.7	0.900	0.300	0.85	22	0.38								
					F	D		O	6							0.8	0.6	26	0.15				
		Crimp ³	N	P	F	G		O	7.5							1.1	0.7	–	22–26	0.38–0.15			
					F	C		O	5									–	28–32	0.09–0.04			
		PCB ⁴	Q	R	F	O		O	6									0.5	–	–			
0	5	Solder	L	M	F	G	0.7	7.5	0.5	0.6	0.600	0.200	0.85	22	0.38								
					F	D		O	6							0.6	1.100	0.366	0.6	26	0.15		
		PCB ⁴	Q	R	F	O		O	0.9							–	–	0.5	–	–			
0	7	Solder	L	M	C	C	0.5	4	0.7	0.6	0.900	0.300	0.4	28	0.08								
		PCB ⁴	Q	R	C	O			O							0.9	–	–	0.5	–	–		
0	9	Solder	L	M	C	C	0.5	4	0.6	0.5	0.600	0.200	0.4	28	0.08								
		PCB ⁴	Q	R	C	O			O							0.7	–	–	0.5	–	–		

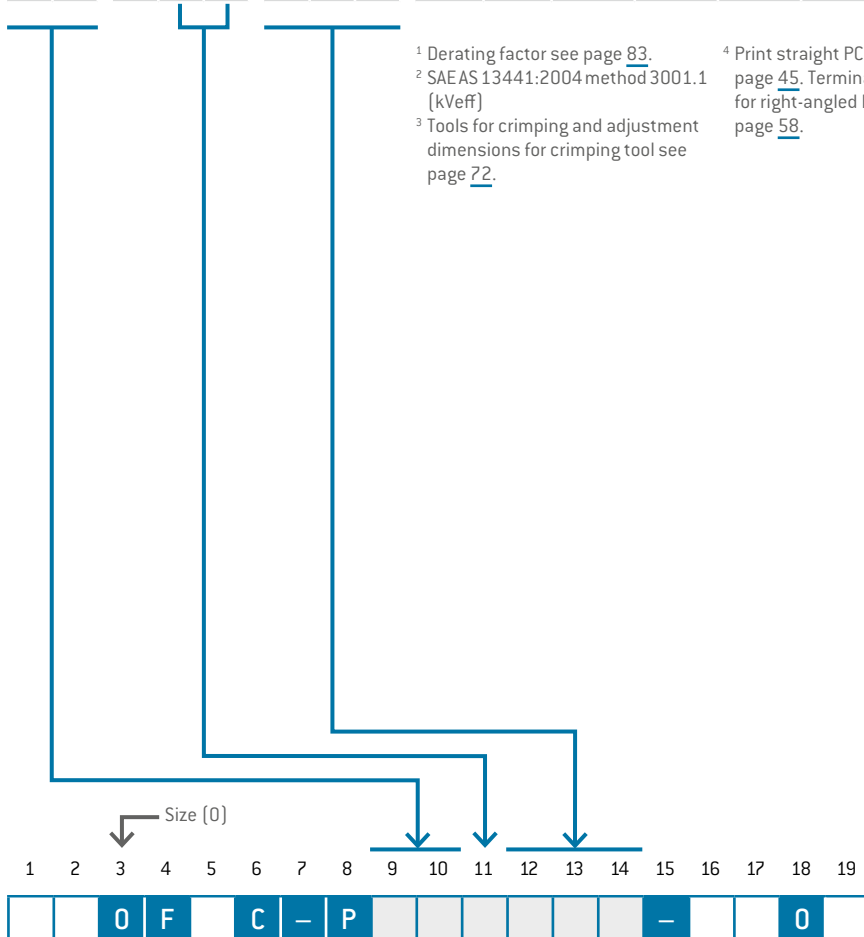

¹ Derating factor see page 83.

² SAE AS 13441:2004 method 3001.1 (kVeff)

³ Tools for crimping and adjustment dimensions for crimping tool see page 22.

⁴ Print straight PCB layouts see from page 45. Termination diameter for right-angled PCB contacts see page 58.

⁵ Max. operating voltage at NN (sea level) to 2,000 m acc. to SAE AS 13441:2004 method 3001.1. Further information on page 84.

PCB LAYOUTS

For PCB contacts [size 0].



	Straight	90° right-angled		Straight	90° right-angled
2 contacts	Hole: 0.8 mm 	Hole: 0.7 mm 			
3 contacts	Hole: 0.8 mm 	Hole: 0.7 mm 			
4 contacts	Hole: 0.6 mm 	Hole: 0.6 mm 			
5 contacts	Hole: 0.6 mm 	Hole: 0.6 mm 			
7 contacts	Hole: 0.6 mm 	Hole: 0.6 mm 			
9 contacts	Hole: 0.6 mm 	Hole: 0.6 mm 			

All specifications are only valid for socket inserts. Pin inserts on request.

CONTACT INSERTS (SIZE 1)



Number of contacts		Contact type			Part number key			Contact diameter mm	Single contact nominal current ¹ A	Clearance and creepage distance		Test voltage ² kVeff	Nominal voltage ⁵ kVrms	Termination diameter mm	Termination cross section		View on termination area														
		Termination	Socket	Pin						Contact to contact mm	Contact to housing mm				AWG	mm ²	Pin piece	Socket piece													
0	2	Solder	L	M	P	N	0	1.3	15	0.8	0.9	1.650	0.550	1.4	18	1.0	18	1.0													
		PCB ⁴	Q	R	P	H	0		12	1.3											1.5	1.1	20	0.5	20	0.5					
					P	O	0															0.7	–	–							
0	3	Solder	L	M	P	N	0	1.3	15	0.5	0.8	1.500	0.500	1.4	18	1.0	22	0.38													
		PCB ⁴	Q	R	P	H	0		12	1.0											1.2	1.1	20	0.5	20	0.5					
0	4	Solder	L	M	J	G	0	0.9	7.5	1.2	0.7	1.500	0.500	0.85	22	0.38	22-24	0.50-0.25													
		Crimp ³	N	P	J	H	0		10	1.5											0.7	–	–	–	–	–	–				
		PCB ⁴	Q	R	J	G	0		7.5	1.2											0.8	1.500	0.500	0.7	–	–	–	–			
					J	O	0																								
0	5	Solder	L	M	J	H	0	0.9	10	0.5	0.8	1.000	0.333	1.1	20	0.50	20-24	0.50-0.25													
		PCB ⁴	Q	R	J	G	0		7.5	0.8											0.8	1.350	0.450	0.85	22	0.38	22-26	0.38-0.15			
		Crimp ³	N	P	J	H	0		10	1.0											0.7	1.000	0.333	–	–	–	–	–	–		
		PCB ⁴	Q	R	J	O	0		7.5	0.8											0.8	1.350	0.450	0.7	–	–	–	–	–		
0	6	Solder	L	M	F	G	0	0.7	7.5	0.6	0.8	1.000	0.333	0.85	22	0.38	22-26	0.38-0.15													
		PCB ⁴	Q	R	F	D	0		6	0.8											0.8	1.200	0.400	0.65	26	0.15	28-32	0.09-0.04			
		Crimp ³	N	P	F	G	0		7.5	0.7											0.6	1.000	0.333	–	–	–	–	–	–		
		PCB ⁴	Q	R	F	C	0		5	1.1											0.8	1.200	0.400	–	–	–	–	–	–		
0	7	Solder	L	M	F	G	0	0.7	7.5	0.6	0.8	1.000	0.333	0.85	22	0.38	22-26	0.38-0.15													
		PCB ⁴	Q	R	F	D	0		6	0.8											0.8	1.200	0.400	0.65	26	0.15	28-32	0.09-0.04			
		Crimp ³	N	P	F	G	0		7.5	0.7											0.6	1.000	0.333	–	–	–	–	–	–		
		PCB ⁴	Q	R	F	C	0		5	1.1											0.8	1.200	0.400	–	–	–	–	–	–		
0	8	Solder	L	M	F	G	0	0.7	7.5	0.4	0.7	0.900	0.300	0.85	22	0.38	22-26	0.38-0.15													
		PCB ⁴	Q	R	F	D	0		6	0.6											0.6	1.000	0.333	0.65	26	0.15	28-32	0.09-0.04			
		Crimp ³	N	P	F	G	0		7.5	0.9											0.7	0.900	0.300	–	–	–	–	–	–		
		PCB ⁴	Q	R	F	C	0		5	0.9											0.7	1.000	0.333	–	–	–	–	–	–		
1	0 ⁶	Solder	L	M	C	D	9	0.5	5	0.3	0.8	0.600	0.200	0.65	26	0.15	28	0.08													
		PCB ⁴	Q	R	C	C	9		4	0.5											0.8	1.000	0.333	0.45	28	0.08					
1	2	Solder	L	M	C	C	0	0.5	4	0.5	0.6	1.100	0.366	0.45	28	0.08	–	–													
		PCB ⁴	Q	R	C	O	0		4	0.8											0.6	1.100	0.366	0.5	–	–					
1	4 ⁶	Solder	L	M	C	C	9	0.5	4	0.4	0.5	0.900	0.300	0.45	28	0.08	–	–													
		PCB ⁴	Q	R	C	O	9		4	0.7											0.5	0.900	0.300	0.5	–	–					

¹ Derating factor see page 83.

² SAE AS 13441:2004 method 3001.1 [kVeff]

³ Tools for crimping and adjustment dimensions for crimping tool see page 72.

⁴ Print straight PCB layouts see page 47. Termination diameter for right-angled PCB contacts see page 58.

⁵ Max. operating voltage at NN (sea level) to 2,000 m acc. to SAE AS 13441:2004 method 3001.1. Further information on page 84.

⁶ Not compatible to competition.

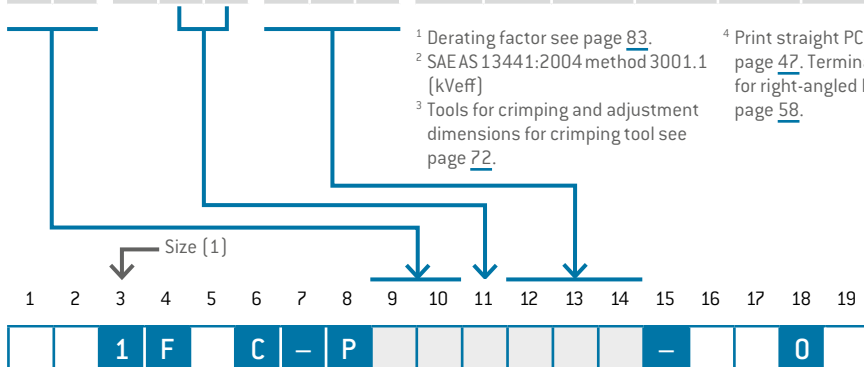

PCB LAYOUTS

For PCB contacts [size 1].



	Straight	90° right-angled		Straight	90° right-angled
2 contacts	Hole: 0.8 mm 	Hole: 0.9 mm 		Hole: 0.6 mm 	Hole: 0.7 mm
3 contacts	Hole: 0.8 mm 	Hole: 0.9 mm 		Hole: 0.6 mm 	on request
4 contacts	Hole: 0.8 mm 	Hole: 0.7 mm 		Hole: 0.6 mm 	on request
5 contacts	Hole: 0.8 mm 	Hole: 0.7 mm 		Hole: 0.6 mm 	on request
6 contacts	Hole: 0.6 mm 	Hole: 0.7 mm 		Hole: 0.6 mm 	Hole: 0.7 mm

All specifications are only valid for socket inserts. Pin inserts on request.

CONTACT INSERTS (SIZE 1.5)



Number of contacts		Contact type			Part number key			Contact diameter mm	Single contact nominal current ¹ A	Clearance and creepage distance		Test voltage ² kVeff	Nominal voltage ⁵ kVrms	Termination diameter mm	Termination cross section		View on termination area								
		Termination	Socket	Pin						Contact to contact mm	Contact to housing mm				AWG	mm ²	Pin piece	Socket piece							
1	0	Solder	L	M	F	G	0	0.7	7.5	0.6	0.6	^1.000	^0.300	0.85	22	0.38									
		PCB ⁴	Q	R	F	D	0		6	0.8									1.200	0.400	0.6	26	0.15		
1	2	Solder	L	M	F	G	0	0.7	7.5	0.4	0.7	1.000	0.300	0.85	22	0.38									
		PCB ⁴	Q	R	F	D	0		6	0.6									1.200	0.400	0.6	26	0.15		
		Crimp ³	N	P	F	G	0		7.5	0.9									1.000	0.300	-	22-26	0.38-0.15		
		PCB ⁴	Q	R	F	C	0		5	0.3									1.200	0.400	-	28-32	0.09-0.04		
		PCB ⁴	Q	R	F	O	0		6	0.3									1.200	0.400	0.5	-	-		
1	9	Solder	L	M	C	C	0	0.5	4	0.6	0.6	1.000	0.333	0.4	28	0.08									
		PCB ⁴	Q	R	C	O	0			0.3									0.5	-	-				

SPECIFIC INSERTS FOR HIGH DATA TRANSMISSION RATES

Ethernet[®]
Type CAT 5
up to 1 Gbit

D	8 ⁶	Solder	L	-	F	G	9	0.9	7.5	0.7	1.8	1.200	0.400	0.85	22	0.38		
		PCB ⁴	Q	-	F	O	9			1.4	1.2			0.5	-	-		
		Solder	-	M	F	G	9			0.7	0.7			0.85	22	0.38		

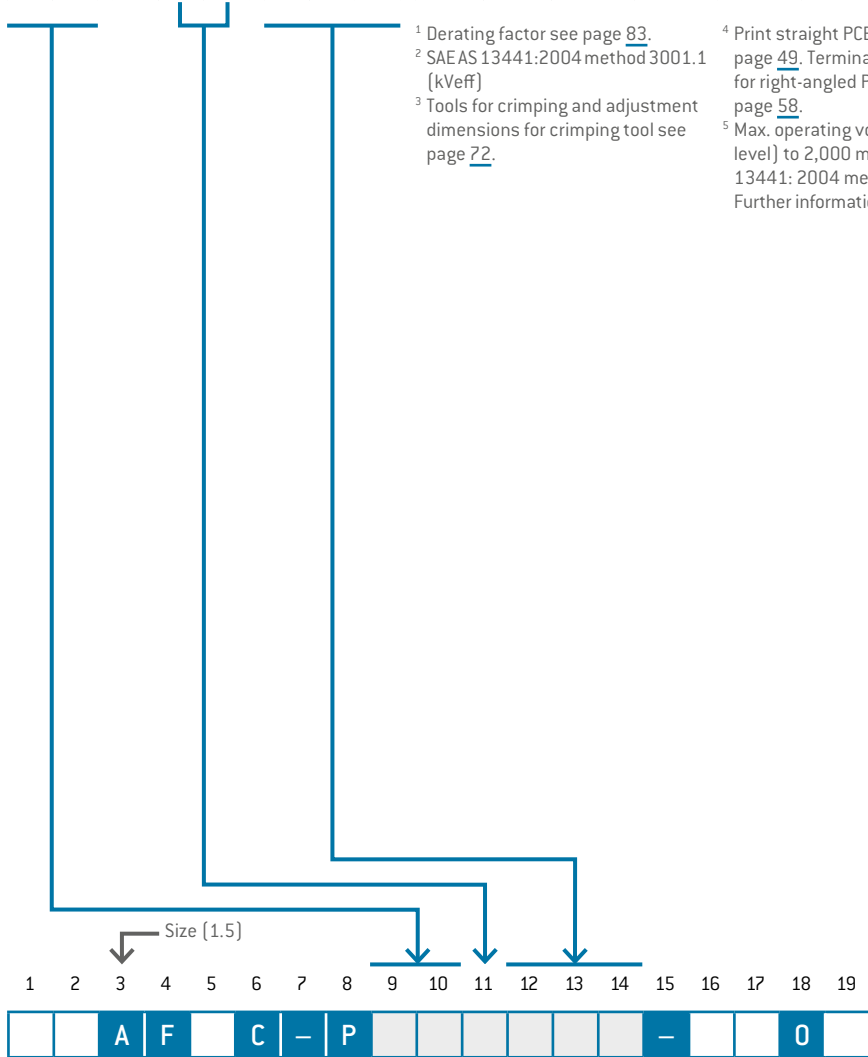

¹ Derating factor see page 83.

² SAE AS 13441:2004 method 3001.1 [kVeff]

³ Tools for crimping and adjustment dimensions for crimping tool see page 72.

⁴ Print straight PCB layouts see from page 49. Termination diameter for right-angled PCB contacts see page 58.
⁵ Max. operating voltage at NN (sea level) to 2,000 m acc. to SAE AS 13441: 2004 method 3001.1. Further information on page 84.

⁶ Not compatible to competition.

⁷ Acc. ISO/IEC 11801:2017. Further information on request.

⁸ For data transmission protocols, please refer to page 2

PCB LAYOUTS

For PCB contacts (size 1.5).



	Straight	90° right-angled	Straight	90° right-angled	
10 contacts	<p>Hole: 0.6 mm</p>	<p>Hole: 0.7 mm</p>	19 contacts	<p>Hole: 0.6 mm</p>	<p>Hole: 0.6 mm</p>
12 contacts	<p>Hole: 0.6 mm</p>	<p>Hole: 0.7 mm</p>	Ethernet ¹ 8 contacts	<p>Hole: 0.6 mm</p>	on request

All specifications are only valid for socket inserts. Pin inserts on request.

¹ For data transmission protocols, please refer to page 2

CONTACT INSERTS (SIZE 2)



Number of contacts		Contact type			Part number key			Contact diameter mm	Single contact nominal current ¹ A	Clearance and creepage distance		Test voltage ² kVeff	Nominal voltage ⁵ kVrms	Termination diameter mm	Termination cross section		View on termination area			
		Termination	Socket	Pin						Contact to contact mm	Contact to housing mm				AWG	mm ²	Pin piece	Socket piece		
0	2	Solder	L	M	S	N	0	1.6	16	2.1	1.6	2.100	0.700	1.4	18	1.00				
		PCB ⁴	Q	R	S	0	0			2.5							1.0	–	–	
0	3	Solder	L	M	S	N	0	1.6	16	1.6	1.5	1.800	0.600	1.4	18	1.00				
		PCB ⁴	Q	R	S	0	0			2.0							1.0	–	–	
0	5	Solder	L	M	P	N	0	1.3	15	0.7	1.1	1.100	0.366	1.4	18	1.00				
		PCB ⁴	Q	R	S	0	0		12										1.2	1.500
		Crimp ³	N	P	P	L	0		15	1.0	0.9	1.100	0.366	–	18–20	1.00–0.50				
		PCB ⁴	Q	R	P	H	0		12											
0	6	Solder	L	M	J	H	0	0.9	10	1.2	1.2	1.500	0.500	1.1	20	0.50				
		PCB ⁴	Q	R	J	G	0		7.5											
		Solder	L	M	J	0	0		7.5	1.8	0.7	–	–							
0	7	Solder	L	M	J	H	0	0.9	10	0.7	1.0	0.900	0.300	1.1	20	0.50				
		PCB ⁴	Q	R	J	G	0		7.5										1.0	1.650
		Solder	L	M	J	0	0		7.5	1.3	0.7	–	–							
0	8	Solder	L	M	J	H	0	0.9	10	0.7	1.1	0.900	0.300	1.1	20	0.50				
		PCB ⁴	Q	R	J	G	0		7.5										1.0	1.500
		Solder	L	M	J	0	0		7.5	1.3	0.7	–	–							
0	9	Solder	L	M	M	0	0	8 x 0.9 1 x 1.3	7.5	0.8 1.8	0.8 3.8	1.350 2.100	0.450 0.700	0.85 1.1	22 20	0.38 0.50				
		PCB ⁴	Q	R					12										1.1 2.1	0.7
1	0 ⁶	Solder	L	M	J	H	9	0.9	10	0.6	0.8	0.900	0.300	1.1	20	0.5				
		PCB ⁴	Q	R	J	G	9		7.5										0.9	1.500
		Crimp ³	N	P	J	H	9		10	1.2	0.8	0.900	0.300	–	20–24	0.50–0.25				
		PCB ⁴	Q	R	J	G	9		7.5										1.500	0.500

¹ Derating factor see page 83.

² SAE AS 13441:2004 method 3001.1 [kVeff]

³ Tools for crimping and adjustment dimensions for crimping tool see page 22.

⁴ Print straight PCB layouts see from page 52. Termination diameter for right-angled PCB contacts see page 58.

⁵ Max. operating voltage at NN [sea level] to 2,000 m acc. to SAE AS 13441:2004 method 3001.1. Further information on page 84.

⁶ Not compatible to competition.

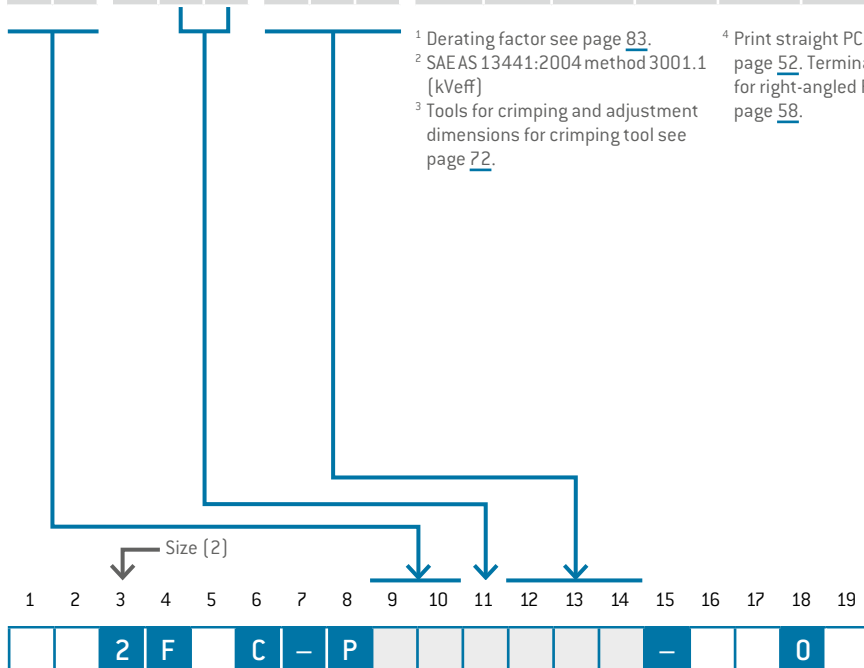

CONTACT INSERTS (SIZE 2)



Number of contacts		Contact type			Part number key			Contact diameter mm	Single contact nominal current ¹ A	Clearance and creepage distance		Test voltage ² kVeff	Nominal voltage ⁵ kVrms	Termination diameter mm	Termination cross section		View on termination area									
		Termination	Socket	Pin						Contact to contact mm	Contact to housing mm				AWG	mm ²	Pin piece	Socket piece								
1	1	Solder	L	M	J	G	0	0.9	7.5	0.8	0.7	1.350	0.450	0.85	22	0.38										
		PCB ⁴	Q	R	J	O	0			1.1									-	-						
1	2 ⁶	Solder	L	M	F	G	9	0.7	7.5	0.7	0.9	1.200	0.400	0.85	22	0.38										
		PCB ⁴	Q	R	F	D	9		6										-	-						
		Crimp ³	N	P	F	G	9		7.5										0.9	1.200	0.400	-	22-26	0.38-0.15		
		PCB ⁴	Q	R	F	C	9		5										1.2	1.350	0.450	-	28-32	0.09-0.04		
		PCB ⁴	Q	R	F	O	9		6										1.1	-	-	0.5	-	-		
1	6	Solder	L	M	F	G	0	0.7	7.5	0.6	0.6	0.900	0.300	0.85	22	0.38										
		PCB ⁴	Q	R	F	D	0		6										0.8	1.100	0.366	0.6	26	0.15		
		Crimp ³	N	P	F	G	0		7.5										0.7	0.900	0.300	-	22-26	0.38-0.15		
		PCB ⁴	Q	R	F	C	0		5										1.1	1.100	0.366	-	28-32	0.09-0.04		
1	9	Solder	L	M	F	G	0	0.7	7.5	0.5	0.6	0.900	0.300	0.85	22	0.38										
		PCB ⁴	Q	R	F	D	0		6										0.7	1.000	0.333	0.6	26	0.15		
		Crimp ³	N	P	F	G	0		7.5										0.7	0.900	0.300	-	22-26	0.38-0.15		
		PCB ⁴	Q	R	F	C	0		5										1.0	1.000	0.333	-	28-32	0.09-0.04		
		PCB ⁴	Q	R	F	O	0		6										1.0	-	-	0.5	-	-		

¹ Derating factor see page 83.

² SAE AS 13441:2004 method 3001.1 (kVeff)

³ Tools for crimping and adjustment dimensions for crimping tool see page 72.

⁴ Print straight PCB layouts see from page 52. Termination diameter for right-angled PCB contacts see page 58.

⁵ Max. operating voltage at NN (sea level) to 2,000 m acc. to SAE AS 13441: 2004 method 3001.1. Further information on page 84.

⁶ Not compatible to competition.

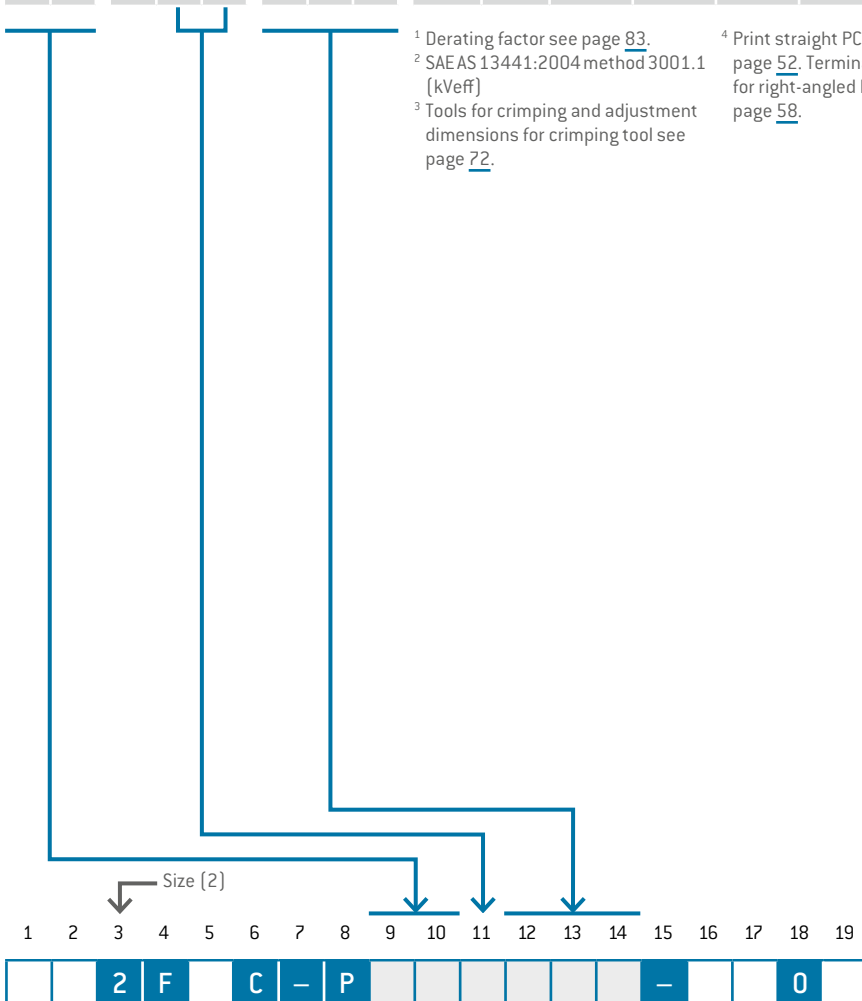

PCB LAYOUTS

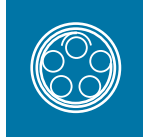

For PCB contacts [size 2].

	Straight	90° right-angled		Straight	90° right-angled
2 contacts	Hole: 1.1 mm 	on request	7 contacts	Hole: 0.8 mm 	on request
3 contacts	Hole: 1.1 mm 	on request	8 contacts	Hole: 0.8 mm 	on request
5 contacts	Hole: 0.8 mm 	Hole: 0.9 mm 	9 contacts	Hole: 0.8 mm 	on request
6 contacts	Hole: 0.8 mm 	Hole: 0.7 mm 	10 contacts	Hole: 0.8 mm 	on request

All specifications are only valid for socket inserts. Pin inserts on request.

PCB LAYOUTS

For PCB contacts [size 2].



	Straight	90° right-angled
11 contacts	<p>Hole: 0.8 mm</p>	<p>Hole: 0.7 mm</p>
12 contacts	<p>Hole: 0.6 mm</p>	<p>on request</p>
16 contacts	<p>Hole: 0.6 mm</p>	<p>Hole: 0.7 mm</p>
19 contacts	<p>Hole: 0.6 mm</p>	<p>Hole: 0.7 mm</p>

All specifications are only valid for socket inserts. Pin inserts on request.

CONTACT INSERTS (SIZE 3)



Number of contacts		Contact type			Part number key			Contact diameter mm	Single contact nominal current ¹ A	Clearance and creepage distance		Test voltage ² kVeff	Nominal voltage ⁵ kVrms	Termination diameter mm	Termination cross section		View on termination area				
		Termination	Socket	Pin						Contact to contact mm	Contact to housing mm				AWG	mm ²	Pin piece	Socket piece			
1	6	Solder	L	M	M	O	O	12 x 0.7 4 x 1.6	6	0.7	0.7	0.900	0.300	0.65	26	0.15					
		PCB ⁴	Q	R						1.0					2.5	1.500			0.500	1.80	14
1	8	Solder	L	M	J	H	O	0.9	10	0.6	0.8	1.000	0.333	1.1	20	0.50					
		PCB ⁴	Q	R	J	G	O		7.5	0.9					1.100	0.366			0.85	22	0.38
		Crimp ³	N	P	J	H	O		10	1.2					1.000	0.333			–	20–24	0.50–0.25
		PCB ⁴	Q	R	J	G	O		7.5	1.2					1.100	0.366			–	22–26	0.38–0.15
2	0 ⁶	Solder	L	M	F	G	9	0.7	7.5	0.7	0.8	1.000	0.333	0.85	22	0.38					
		PCB ⁴	Q	R	F	D	9		6	0.9					1.100	0.366			0.6	26	0.15
		Crimp ³	N	P	F	G	9		7.5	0.8					1.000	0.333			–	22–26	0.38–0.15
		PCB ⁴	Q	R	F	C	9		5	0.8					1.100	0.366			–	28–32	0.09–0.04
2	2 ⁶	Solder	L	M	F	G	9	0.7	7.5	0.7	0.7	1.000	0.333	0.85	22	0.38					
		PCB ⁴	Q	R	F	D	9		6	0.9					1.100	0.366			0.6	26	0.15
		Crimp ³	N	P	F	G	9		7.5	0.5					1.000	0.333			–	22–26	0.38–0.15
		PCB ⁴	Q	R	F	C	9		5	0.5					1.100	0.366			–	28–32	0.09–0.04
2	4	Solder	L	M	F	G	0	0.7	7.5	0.5	0.7	0.900	0.300	0.85	22	0.38					
		PCB ⁴	Q	R	F	D	0		6	0.7					1.000	0.333			0.6	26	0.15
2	6 ⁶	Solder	L	M	F	G	9	0.7	7.5	0.5	0.6	0.900	0.300	0.85	22	0.38					
		PCB ⁴	Q	R	F	D	9		6	0.7					1.000	0.333			0.6	26	0.15
		Crimp ³	N	P	F	G	9		7.5	0.3					0.900	0.300			–	22–26	0.38–0.15
		PCB ⁴	Q	R	F	C	9		5	0.3					1.000	0.333			–	28–32	0.09–0.04
2	7	Solder	L	M	F	G	0	0.7	7.5	0.5	0.7	0.900	0.300	0.85	22	0.38					
		PCB ⁴	Q	R	F	D	0		6	0.7					1.000	0.333			0.6	26	0.15
		Crimp ³	N	P	F	G	0		7.5	0.6					0.900	0.300			–	22–26	0.38–0.15
		PCB ⁴	Q	R	F	C	0		5	0.6					1.000	0.333			–	28–32	0.09–0.04
2	7	Solder	L	M	F	G	0	0.7	7.5	0.5	0.7	0.900	0.300	0.85	22	0.38					
		PCB ⁴	Q	R	F	D	0		6	0.7					1.000	0.333			0.6	26	0.15
2	7	Crimp ³	N	P	F	G	0	0.7	7.5	0.6	0.7	0.900	0.300	0.85	22	0.38					
		PCB ⁴	Q	R	F	C	0		5	0.6					1.000	0.333			–	28–32	0.09–0.04
2	7	Solder	L	M	F	G	0	0.7	7.5	0.5	0.7	0.900	0.300	0.85	22	0.38					
		PCB ⁴	Q	R	F	D	0		6	0.7					1.000	0.333			0.6	26	0.15
2	7	Crimp ³	N	P	F	G	0	0.7	7.5	0.6	0.7	0.900	0.300	0.85	22	0.38					
		PCB ⁴	Q	R	F	C	0		5	0.6					1.000	0.333			–	28–32	0.09–0.04
2	7	Solder	L	M	F	G	0	0.7	7.5	0.5	0.7	0.900	0.300	0.85	22	0.38					
		PCB ⁴	Q	R	F	D	0		6	0.7					1.000	0.333			0.6	26	0.15
2	7	Crimp ³	N	P	F	G	0	0.7	7.5	0.6	0.7	0.900	0.300	0.85	22	0.38					
		PCB ⁴	Q	R	F	C	0		5	0.6					1.000	0.333			–	28–32	0.09–0.04

¹ Derating factor see page 83.

² SAE AS 13441:2004 method 3001.1 [kVeff]

³ Tools for crimping and adjustment dimensions for crimping tool see page 72.

⁴ Print straight PCB layouts see from page 56. Termination diameter for right-angled PCB contacts see page 58.

⁵ Max. operating voltage at NN (sea level) to 2,000 m acc. to SAE AS 13441: 2004 method 3001.1. Further information on page 84.

⁶ Not compatible to competition.

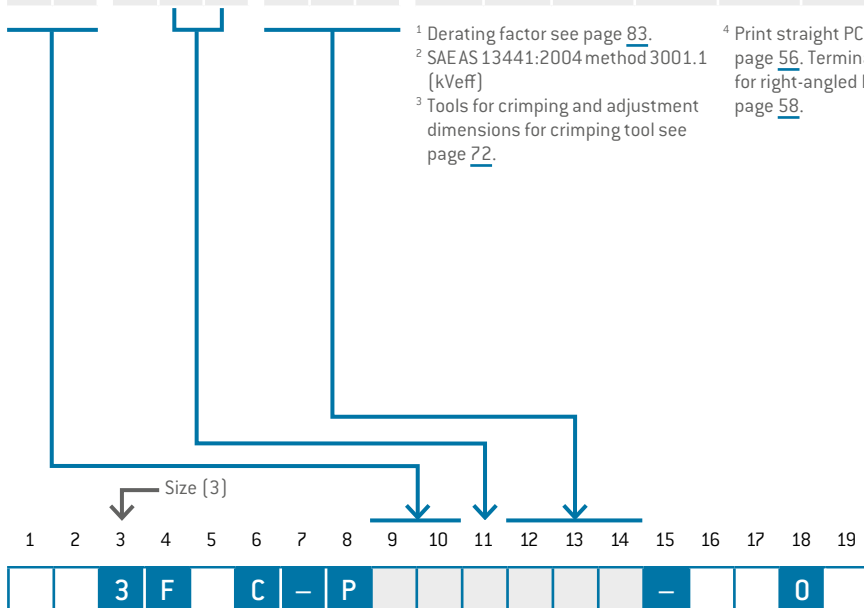

PCB LAYOUTS

For PCB contacts [size 3].



	Straight	90° right-angled		Straight	90° right-angled
4 contacts	<p>Hole: 0.8 mm</p>	<p>on request</p>	12 contacts	<p>Hole: 0.8 mm</p>	on request
7 contacts	<p>Hole: 0.8 mm</p>	on request	14 contacts	<p>Hole: 0.8 mm</p>	<p>Hole: 0.7 mm</p>
8 contacts	<p>Hole: 0.8 mm</p>	on request	15 contacts	<p>Hole: 0.8 mm</p>	on request
10 contacts	<p>Hole: 0.8 mm</p>	on request	16 contacts		on request

All specifications are only valid for socket inserts. Pin inserts on request.

PCB LAYOUTS

For PCB contacts (size 3).



	Straight	90° right-angled	Straight	90° right-angled
18 contacts	Hole: 0.8 mm 	on request	Hole: 0.6 mm 	Hole: 0.7 mm
20 contacts	Hole: 0.6 mm 	Hole: 0.7 mm 	Hole: 0.6 mm 	on request
22 contacts	Hole: 0.6 mm 	on request	Hole: 0.6 mm 	Hole: 0.7 mm

All specifications are only valid for socket inserts. Pin inserts on request.

RIGHT-ANGLED PCB CONTACTS IN THE RECEPTACLE



A

RIGHT-ANGLED PCB CONTACT

For style G5, G8 and GK.

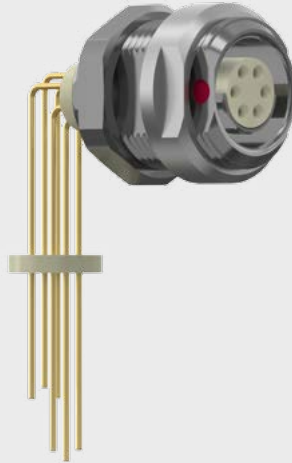

TECHNICAL DATA

- Pin version on request
- PCB layouts see from page [45](#)

Contact diameter	Termination diameter
mm	mm
0.5	0.5
0.7	0.6
0.9	0.6
1.3	0.8
1.6	0.8
2	0.8

1 2 3 4 5 6 7 8 9 10 11 12 13 14 15 16 17 18 19

F C - P 0 0 - 0 0 0

COLOUR CODING RINGS

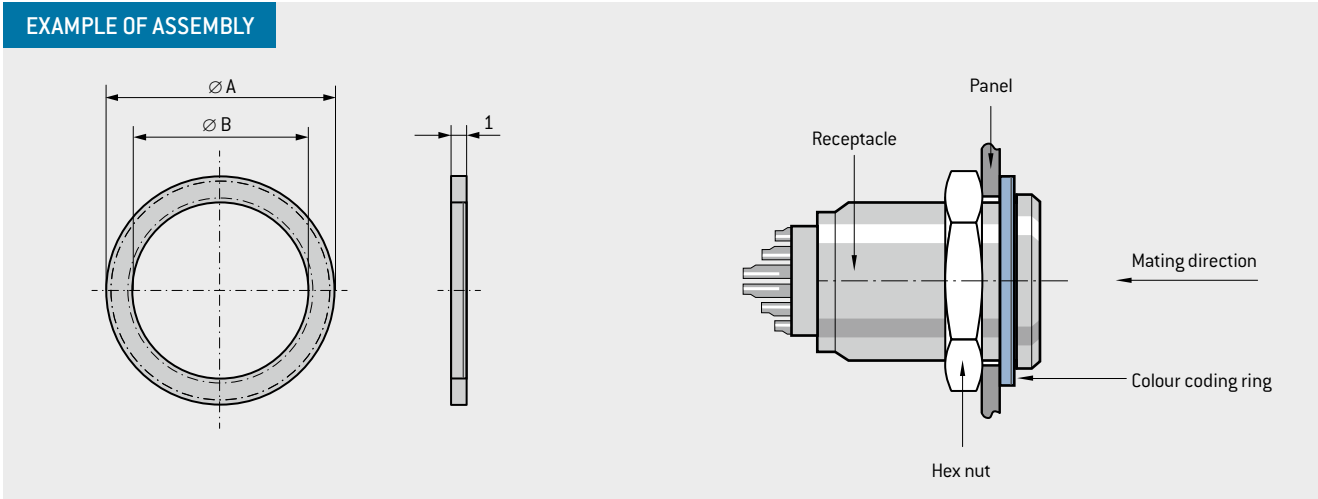

Material: Plastic PA66

SIZES

Thread	Part number	Ø A mm	Ø B mm
M 9	700.422.____.922.009	13.5	9.1
M 10	700.422.____.922.010	16.5	10.1
M 12	701.422.____.922.012	17	12.1
M 14	701.422.____.922.014	20	14.1
M 14	715.422.____.922.014	21	14.1
M 15	702.422.____.922.015	22	15.1
M 16	702.422.____.922.016	23	16.1
M 18	703.422.____.922.018	25	18.1
M 20	703.422.____.922.020	28	20.1

COLOURS

Colour code	Colour	RAL no. ¹ (similar)
202	Red	3020
203	White	9010
204	Yellow	1016
205	Green	6029
206	Blue	5002
207	Grey	7005
208	Black	9005

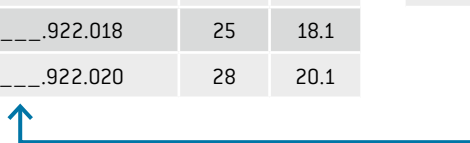

HOW TO PLACE THE RIGHT ORDER:

This shows you how the part number of the colour coding rings is composed. In the first step, select the size and note the part number. Put the colour code and part number together depending on your choice of colour (see example).

STEP 1:	Choose size	700.422.____.922.009
STEP 2:	Choose colour	... 202 ...
STEP 3:	Completed part number	700.422.202.922.009

¹ Because of different raw materials the colours may slightly differ from RAL numbers.

DISTANCE RINGS FOR WALL-THICKNESS ADJUSTMENT



EXAMPLE OF ASSEMBLY FOR RECEPTACLE STYLE 2¹

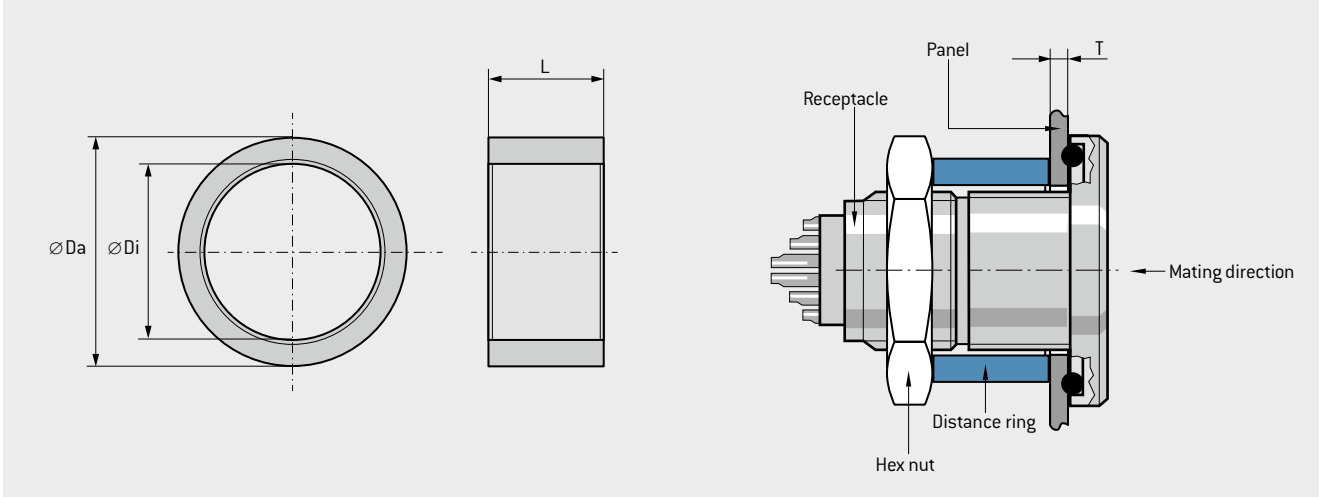

Size	Part number	Da mm	Di mm	L mm	T mm
0	700.123.102.304.000	13	10.3	7	1 – 6
1 / 1.5	701.123.102.304.000 ²	17	14.3	12	0.5 – 3
1 / 1.5	701.123.102.304.001 ³	17	14.3	6	3 – 9
2	702.123.102.304.000	21	16.3	8	1 – 8
3	703.123.102.304.000	25	20.3	11.5	0.5 – 7

¹ See page 38

² Wall thickness: 0.5 – 6 mm

³ Wall thickness: 6 – 16 mm

Material: brass

Surface: nickel

PROTECTIVE COVERS



FOR PLUGS (IP 50)

Size	Part number	A mm	Ø B mm	C mm	Ø D mm	Ø E mm
0	700.097.005.215._00	15.5	10	70	8	3.2
1	701.097.005.215._00	16.5	12	75	10	
1.5	715.097.005.215._00	15.5	13	80	11	
2	702.097.005.215._00	18	15	85	13	
3	703.097.005.215._00	20.5	18	100	16	

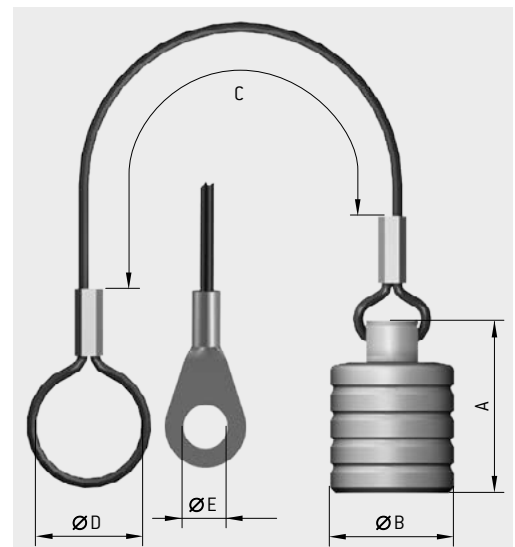

Material lanyard	
0	Polyamide lanyard with loop (Ø D)
1	Stainless steel lanyard with loop (Ø D)
2	Polyamide lanyard with solder lug (Ø E)
3	Stainless steel lanyard with solder lug (Ø E)

Surface matt chrome

FOR PLUGS (IP 68)

Size	Part number	A mm	Ø B mm	C mm	Ø D mm	Ø E mm
0	700.097.004.215._00	15.5	10.5	70	8	3.2
1	701.097.004.215._00	16.5	13	75	10	
1.5	715.097.004.215._00	16	13.5	80	11	
2	702.097.004.215._00	18.5	16	85	13	
3	703.097.004.215._00	21	19	100	16	

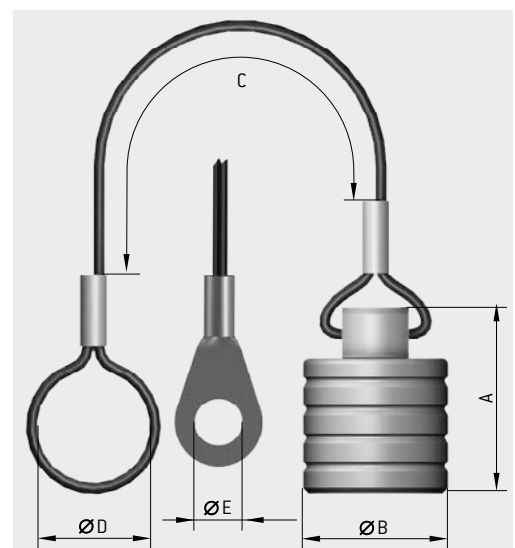

Material lanyard	
0	Polyamide lanyard with loop (Ø D)
1	Stainless steel lanyard with loop (Ø D)
2	Polyamide lanyard with solder lug (Ø E)
3	Stainless steel lanyard with solder lug (Ø E)

Surface matt chrome

PROTECTIVE COVERS



FOR RECEPTACLES (IP 50)

Size	Part number	A mm	Ø B mm	C mm	Ø D mm	Ø E mm
0	700.097.003.215._00	10.5	10	70	8	3.2
1	701.097.003.215._00	12.5	12	75	13	
1.5	715.097.003.215._00	13.3	13	80	11	
2	702.097.003.215._00	15	15	85	13	
3	703.097.003.215._00	16.6	18	100	16	

Material lanyard	
0	Polyamide lanyard with loop (Ø D)
1	Stainless steel lanyard with loop (Ø D)
2	Polyamide lanyard with solder lug (Ø E)
3	Stainless steel lanyard with solder lug (Ø E)

Surface matt chrome

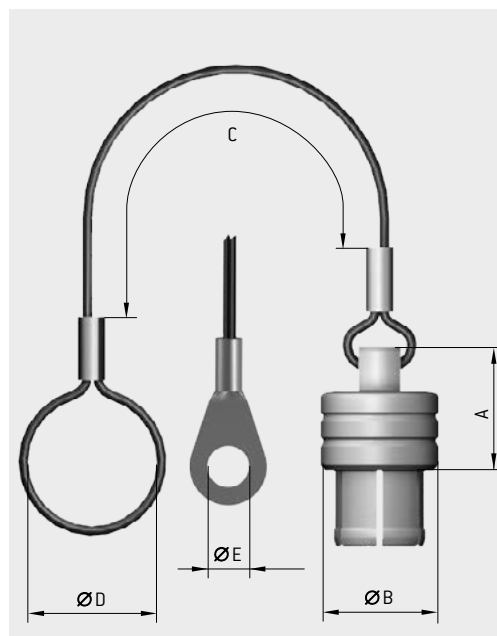

FOR RECEPTACLE (IP 68)

Size	Part number	A mm	Ø B mm	C mm	Ø D mm	Ø E mm
0	700.097.007.215._00	10	10	70	8	3.2
1	701.097.007.215._00	12	12	75	10	
1,5	715.097.007.215._00	13.3	13	80	11	
2	702.097.007.215._00	15	15	85	13	
3	703.097.007.215._00	17	18	100	16	

Material lanyard	
0	Polyamide lanyard with loop (Ø D)
1	Stainless steel lanyard with loop (Ø D)
2	Polyamide lanyard with solder lug (Ø E)
3	Stainless steel lanyard with solder lug (Ø E)

Surface matt chrome

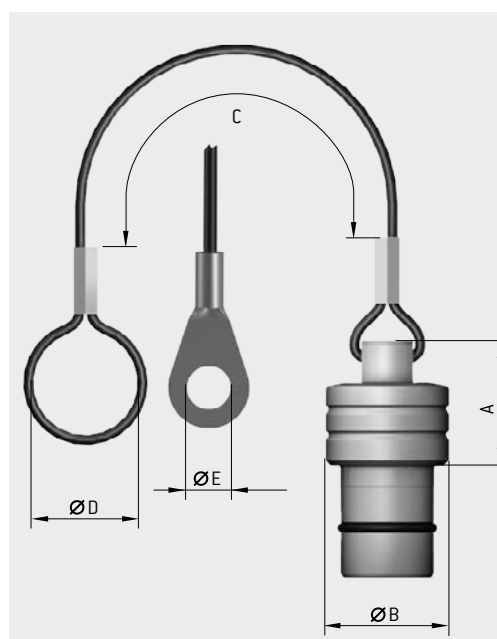

SILICONE CABLE BEND RELIEFS



Size	Part number	Dim. L mm	Cable jacket (∅ outside)	
			min.	max.
0	700.023.____.965.020	27	2	2.5
	700.023.____.965.025		2.5	3
	700.023.____.965.030		3	3.5
	700.023.____.965.035		3.5	4
	700.023.____.965.040		4	4.5
	700.023.____.965.045		4.5	5
1	701.023.____.965.025	30	2.5	3
	701.023.____.965.030		3	3.5
	701.023.____.965.035		3.5	4
	701.023.____.965.040		4	5
	701.023.____.965.050		5	6
	701.023.____.965.060		6	6.5
	701.023.____.965.070		6.5	7.5
1.5	715.023.____.965.030	36	3.0	3.5
	715.023.____.965.040		4.0	5.0
	715.023.____.965.050		5.0	6.0
	715.023.____.965.060		6.0	7.0
	715.023.____.965.070		7.0	8.0
2	702.023.____.965.025	36	2.5	3
	702.023.____.965.030		3	3.5
	702.023.____.965.035		3.5	4
	702.023.____.965.040		4	5
	702.023.____.965.050		5	6
	702.023.____.965.060		6	7
	702.023.____.965.070		7	8
	702.023.____.965.080		8	9
3	703.023.____.965.040	42	4	5
	703.023.____.965.050		5	6
	703.023.____.965.060		6	7
	703.023.____.965.070		7	8
	703.023.____.965.080		8	9
	703.023.____.965.090		9	10
	703.023.____.965.100		10	11
	703.023.____.965.110		11	12

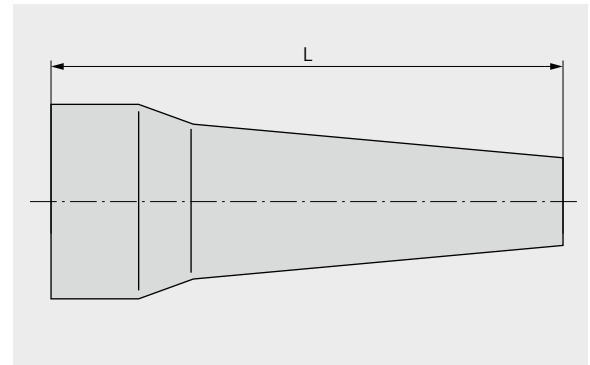

TEMPERATURE RANGE

Silicone: -50 °C up to +200 °C, short duration up to +230 °C
Autoclaveable

COLOURS

Colour code	Colour	RAL no. ¹ (similar)
202	Red	3020
203	White	9010
204	Yellow	1016
205	Green	6029
206	Blue	5002
207	Grey	7005
208	Black	9005



¹ Because of different raw materials the colours may slightly differ from RAL numbers.

BACK NUT FOR CABLE BEND RELIEFS



EXAMPLE OF ASSEMBLY

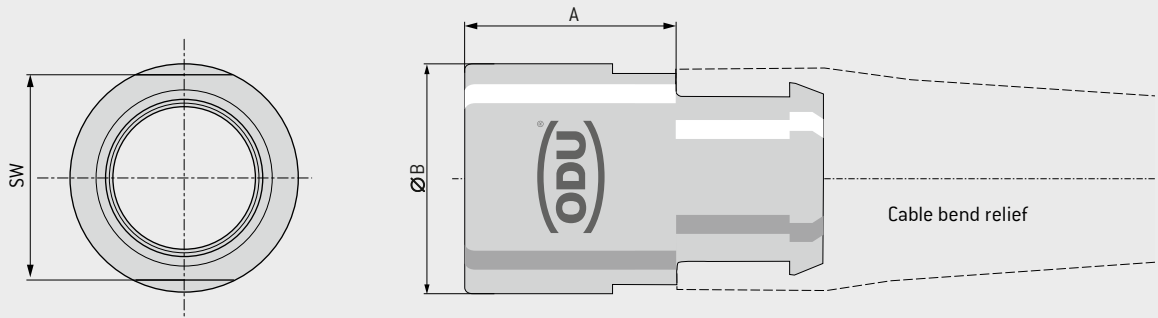

Size	Part number	A	Ø B	SW
		mm	mm	mm
0	700.022.117.3___.002	8	8.9	7
1	701.022.117.3___.002	10	10.9	10
1.5	715.022.117.3___.002	11	12.9	12
2	702.022.117.3___.002	11.5	13.9	13
3	703.022.117.3___.002	11.5	16.9	15

Surface		
15	Cu alloy / matt chrome plated	Standard
11	Cu alloy / black chrome plated	on request
04	Cu alloy / nickel	on request



LOCK WASHERS



EXAMPLE OF ASSEMBLY

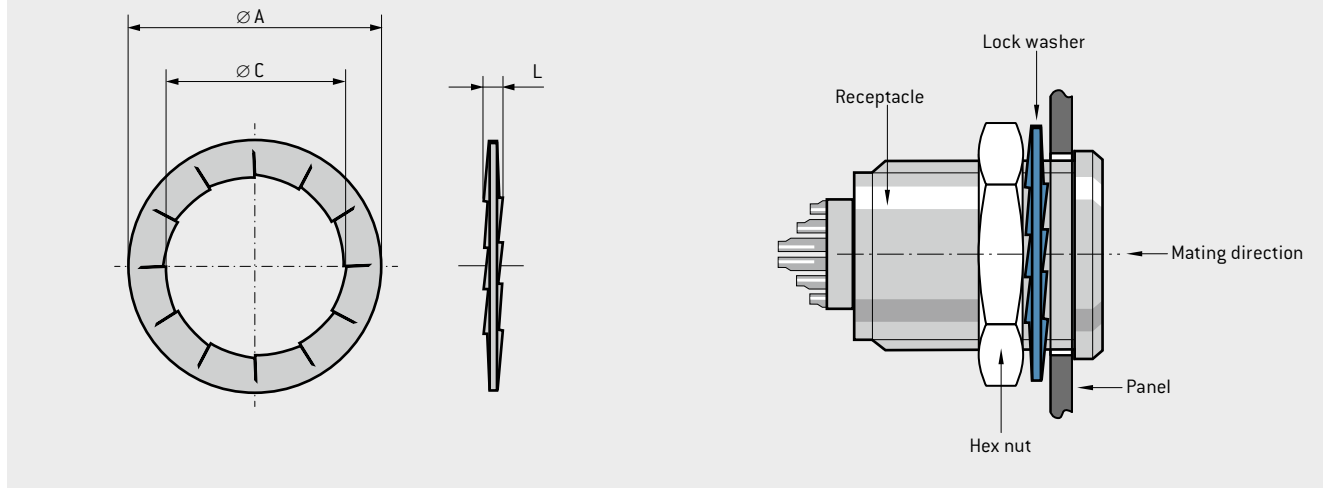

Thread	Part number	Ø A mm	Ø C mm	L mm
M9	945.000.001.000.046	12.5	9.1	1
M12	945.000.001.000.047	16	12.1	1.1
M14	945.000.001.000.070	19.5	14.2	1.1
M15	945.000.001.000.048	19.5	15.1	1.1
M16	945.000.001.000.072	21.5	16.1	1.1
M18	945.000.001.000.049	25	18.1	1.1
M20	945.000.001.000.121	25	20.1	1.1

Nickel plated surface

SOLDERING LUGS



EXAMPLE OF ASSEMBLY

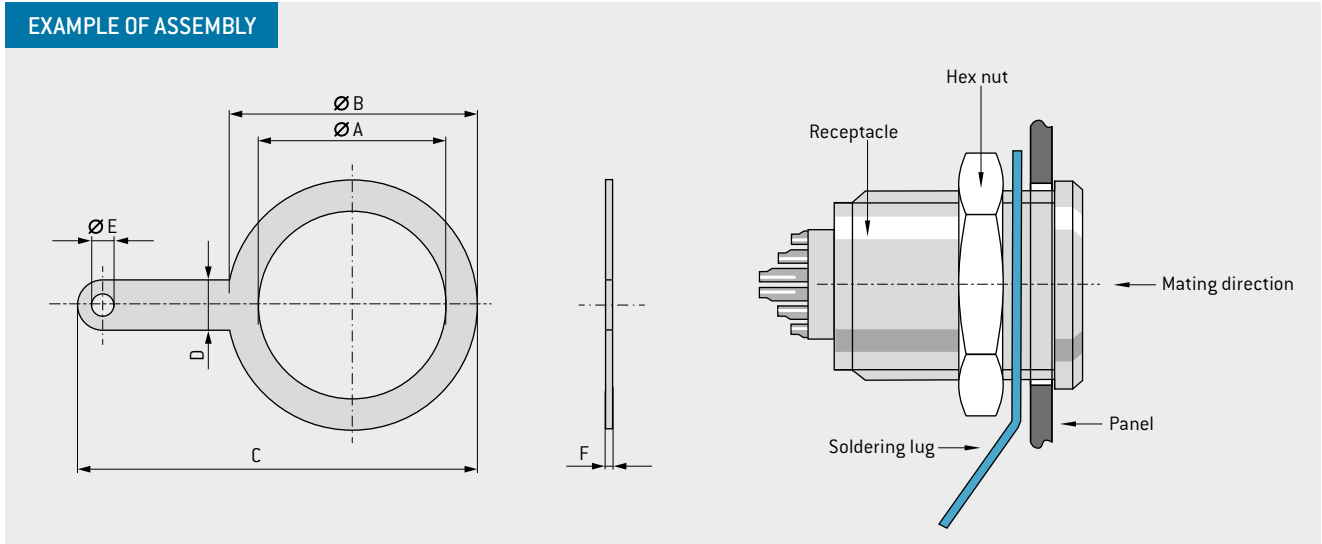

Thread	Part number	Ø A mm	Ø B mm	C mm	D mm	Ø E mm	F mm
M9	700.140.246.301.000	9.7	13.2	21.6	4	1.6	0.5
M12	701.140.246.301.000	12.2	17	27.5	4	1.6	0.5
M14	715.140.246.301.000	14.1	18	27	4	2	0.5
M15	702.140.246.301.000	15.2	20	32	4	1.6	0.5
M16	721.140.246.301.000	16.2	20	32	4	1.6	0.5
M18	703.140.246.301.000	18.2	25	39	4	1.6	0.5
M20	722.140.246.301.000	20.2	25	39	4	1.6	0.5

Silver plated surface

FOR YOUR NOTES

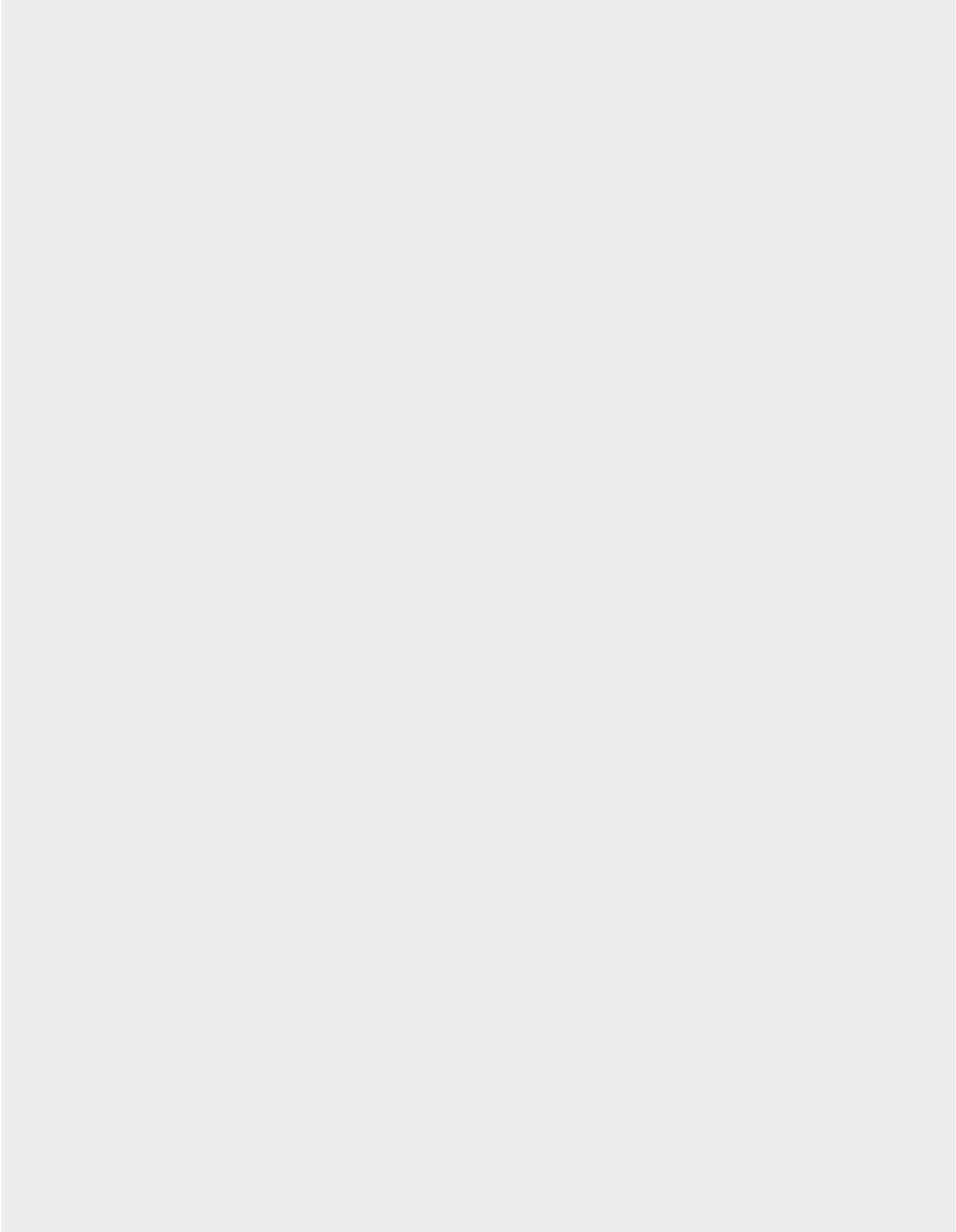



ODU MINI-SNAP®

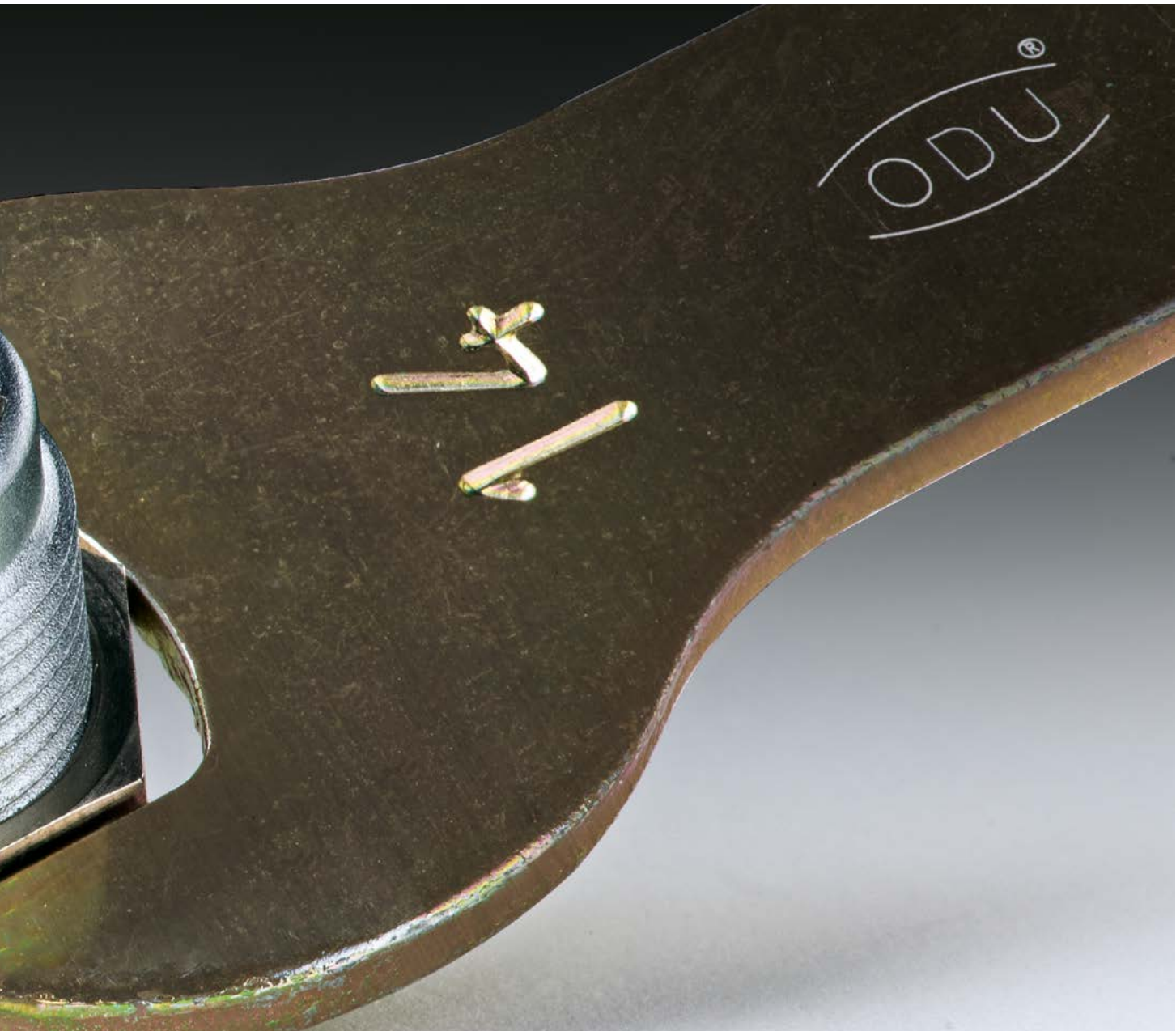

TOOLS

The following pages contain tools and wrenches to ensure that your ODU connectors function flawlessly.

CRIMPING TOOLS / ASSEMBLY TOOLS



PART NUMBER CRIMPING TOOL
080.000.051.000.000

Part number positioner
 see table.

PROCESSING TOOLS FOR CRIMP CONTACTS

Size	Number of contacts	Contact diameter mm	Termination cross-section		Adjustment dimension mm	Positioner	Positioning setting		Removal tool
			AWG	mm ²			Pin	Socket	
0	4	0.7	28 – 32	0.09 – 0.04	0.57	080.000.051.108.000	1	2	087.7CC.070.001.000
	4	0.7	22 – 26	0.38 – 0.15	0.67	080.000.051.108.000	1	2	087.7CC.070.001.000
1	6 – 8	0.7	28 – 32	0.09 – 0.04	0.57	080.000.051.108.000	3	4	087.7CC.070.001.000
	6 – 8	0.7	22 – 26	0.38 – 0.15	0.67	080.000.051.108.000	3	4	087.7CC.070.001.000
	4 – 5	0.9	22 – 26	0.38 – 0.15	0.67	080.000.051.108.000	5	6	087.7CC.090.001.000
	4 – 5	0.9	20 – 24	0.50 – 0.25	0.67	080.000.051.108.000	5	6	087.7CC.090.001.000
1.5	12	0.7	28 – 32	0.09 – 0.04	0.57	080.000.051.108.000	3	7	087.7CC.070.001.000
	12	0.7	22 – 26	0.38 – 0.15	0.67	080.000.051.108.000	3	7	087.7CC.070.001.000
2	16 – 19	0.7	28 – 32	0.09 – 0.04	0.57	080.000.051.110.000	1	2	087.7CC.070.001.000
	16 – 19	0.7	22 – 26	0.38 – 0.15	0.67	080.000.051.110.000	1	2	087.7CC.070.001.000
	12	0.7	28 – 32	0.09 – 0.04	0.57	080.000.051.106.000	1	2	087.7CC.070.001.000
	12	0.7	22 – 26	0.38 – 0.15	0.67	080.000.051.106.000	1	2	087.7CC.070.001.000
	10	0.9	22 – 26	0.38 – 0.15	0.67	080.000.051.106.000	3	4	087.7CC.090.001.000
	10	0.9	20 – 24	0.50 – 0.25	0.67	080.000.051.106.000	3	4	087.7CC.090.001.000
	5	1.3	20 – 24	0.50 – 0.25	0.67	080.000.051.110.000	3	4	087.7CC.130.001.000
	5	1.3	18 – 20	1 – 0.50	1.12	080.000.051.110.000	3	4	087.7CC.130.001.000
3	27	0.7	28 – 32	0.09 – 0.04	0.57	080.000.051.110.000	1	6	087.7CC.070.001.000
	27	0.7	22 – 26	0.38 – 0.15	0.67	080.000.051.110.000	1	6	087.7CC.070.001.000
	20 – 26	0.7	28 – 32	0.09 – 0.04	0.57	080.000.051.106.000	1	7	087.7CC.070.001.000
	20 – 26	0.7	22 – 26	0.38 – 0.15	0.67	080.000.051.106.000	1	7	087.7CC.070.001.000
	15 – 18	0.9	22 – 26	0.38 – 0.15	0.67	080.000.051.110.000	7	8	087.7CC.090.001.000
	15 – 18	0.9	20 – 24	0.50 – 0.25	0.67	080.000.051.110.000	7	8	087.7CC.090.001.000
	14	0.9	22 – 26	0.38 – 0.15	0.67	080.000.051.106.000	3	8	087.7CC.090.001.000
	14	0.9	20 – 24	0.50 – 0.25	0.67	080.000.051.106.000	3	8	087.7CC.090.001.000
	8	1.3	20 – 24	0.50 – 0.25	0.67	080.000.051.106.000	5	9	087.7CC.130.001.000
	8	1.3	18 – 20	1 – 0.50	1.12	080.000.051.106.000	5	9	087.7CC.130.001.000
	7	1.6	18 – 20	1 – 0.50	1.12	080.000.051.107.000	1	5	087.7CC.160.001.000
	7	1.6	18	1.50 – 1	1.12	080.000.051.107.000	1	5	087.7CC.160.001.000
	7	1.6	14 – 18	1.50 – 1	1.30	080.000.051.107.000	1	5	087.7CC.160.001.000

CRIMPING TOOLS / ASSEMBLY TOOLS



PART NUMBER CRIMPING TOOL

080.000.037.000.000

Part number positioner
see table.

PROCESSING TOOLS FOR CRIMP CONTACTS

Size	Number of contacts	Contact diameter mm	Termination cross-section		Positioner		Selector number		Removal tool
			AWG	mm ²	Pin	Socket	Pin	Socket	
0	4	0.7	28 – 32	0.09 – 0.04	081.701.002.848.037	081.700.005.748.037	3	3	082.7CC.070.001.000
	4	0.7	22 – 26	0.38 – 0.15	081.701.002.848.037	081.700.004.748.037	4	4	082.7CC.070.001.000
1	6 – 8	0.7	28 – 32	0.09 – 0.04	081.702.001.848.037	081.701.002.748.037	3	3	082.7CC.070.001.000
	6 – 8	0.7	22 – 26	0.38 – 0.15	081.702.001.848.037	081.701.002.748.037	4	4	082.7CC.070.001.000
	4 – 5	0.9	22 – 26	0.38 – 0.15	081.701.002.849.037	081.701.002.749.037	4	4	082.7CC.090.001.000
	4 – 5	0.9	20 – 24	0.50 – 0.25	081.701.003.849.037	081.701.003.749.037	7/6/5 ¹	7/6/5 ¹	082.7CC.090.001.000
1.5	12	0.7	28 – 32	0.09 – 0.04	081.702.001.848.037	081.700.001.748.037	3	3	082.7CC.070.001.000
	12	0.7	22 – 26	0.38 – 0.15	081.702.001.848.037	081.700.001.748.037	4	4	082.7CC.070.001.000
2	12 – 19	0.7	28 – 32	0.09 – 0.04	081.702.001.848.037	081.702.001.748.037	3	3	082.7CC.070.001.000
	12 – 19	0.7	22 – 26	0.38 – 0.15	081.702.001.848.037	081.702.001.748.037	4	4	082.7CC.070.001.000
	10	0.9	22 – 26	0.38 – 0.15	081.701.002.849.037	081.702.003.749.037	4	4	082.7CC.090.001.000
	10	0.9	20 – 24	0.5 – 0.25	081.701.003.849.037	081.702.002.749.037	7/6/5 ¹	7/6/5 ¹	082.7CC.090.001.000
3	27	0.7	28 – 32	0.09 – 0.04	081.702.001.848.037	081.703.002.748.037	3	3	082.7CC.070.001.000
	27	0.7	22 – 26	0.38 – 0.15	081.702.001.848.037	081.703.004.748.037	4	4	082.7CC.070.001.000
	20-26	0.7	28 – 32	0.09 – 0.04	081.702.001.848.037	081.703.002.748.037	3	3	082.7CC.070.001.000
	20-26	0.7	22 – 26	0.38 – 0.15	081.702.001.848.037	081.703.002.748.037	4	4	082.7CC.070.001.000
	15-18	0.9	22 – 26	0.38 – 0.15	081.701.002.849.037	081.702.003.749.037	4	4	082.7CC.090.001.000
	15-18	0.9	20 – 24	0.50 – 0.25	081.701.003.849.037	081.702.002.749.037	7/6/5 ¹	7/6/5 ¹	082.7CC.090.001.000
	14	0.9	22 – 26	0.38 – 0.15	081.701.002.849.037	081.703.003.749.037	4	4	082.7CC.090.001.000
	14	0.9	20 – 24	0.50 – 0.25	081.701.003.849.037	081.703.002.749.037	7/6/5 ¹	7/6/5 ¹	082.7CC.090.001.000

¹ For AWG 20 position 7 / for AWG 22 position 6 / for AWG 24 position 5

SPANNER WRENCH

Part number	Dimensions in mm				
	SW	t	B	L	b
598.700.001.016.000	5	1.5	16	92	8
598.700.001.015.000	5.5	1.5	16	92	8
598.700.001.021.000	6	2	16	92	8
598.700.001.011.000	7	2	16	92	8
598.700.001.001.000	8	2	16	92	8
598.700.001.022.000	9	2	21.5	102	9
598.700.001.002.000	10	2	21.5	102	9
598.700.001.012.000	11	2	24.5	115	10
598.700.001.013.000	12	2.5	24.5	115	10
598.700.001.017.000	12.5	4	24.5	115	10
598.700.001.004.000	13	2.5	30.5	98	16.5
598.700.001.005.000	14	2.5	30.5	98	16.5
598.700.001.006.000	15	3	35.5	145	15
598.700.001.007.000	16	3	35.5	145	15
598.700.001.008.000	17	3	35.5	145	15
598.700.001.023.000	18	3	42	172	16
598.700.001.013.000	19	3	42	172	16
598.700.001.009.000	20	3	42	172	16
598.700.001.018.000	21	3	42	172	16
598.700.001.010.000	22	3	47	119	23.5
598.700.001.014.000	24	3	54	119	23.5
598.700.001.024.000	27	3	55	150	25
598.700.001.019.000	30	3	50	150	25
598.700.001.020.000	31	3	50	150	25

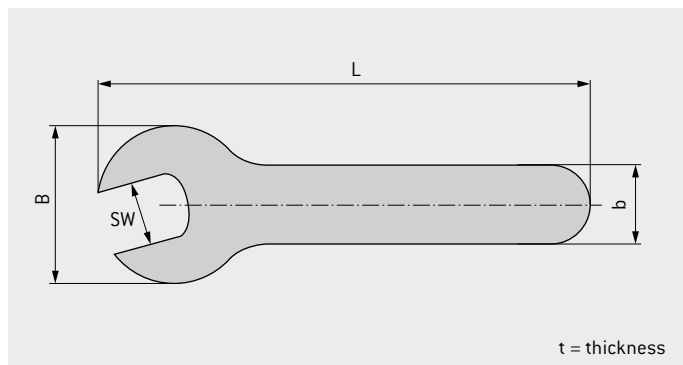

NUTDRIVER FOR SLOTTED MOUNTING NUT



Nutdriver	Thread	Length in mm L	Compatible with part number
700.098.002.000.000	M9 × 0.5	50	G80F.-
701.098.002.000.000	M14 × 1	60	G81F.- and G8AF.-
702.098.001.000.000	M16 × 1	60	G82F.-
703.098.001.000.000	M20 × 1	60	G83F.-

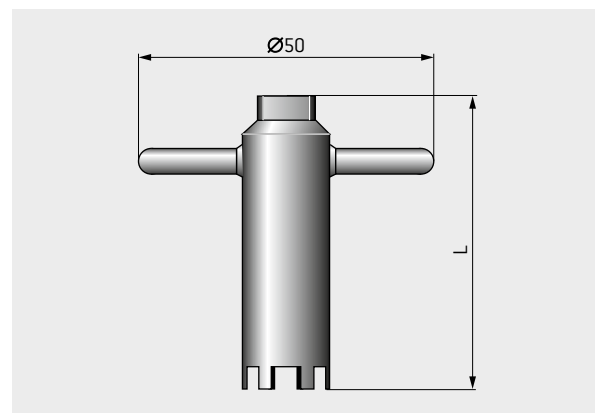

REMOVAL TOOLS FOR CRIMP-CLIP-CONTACTS

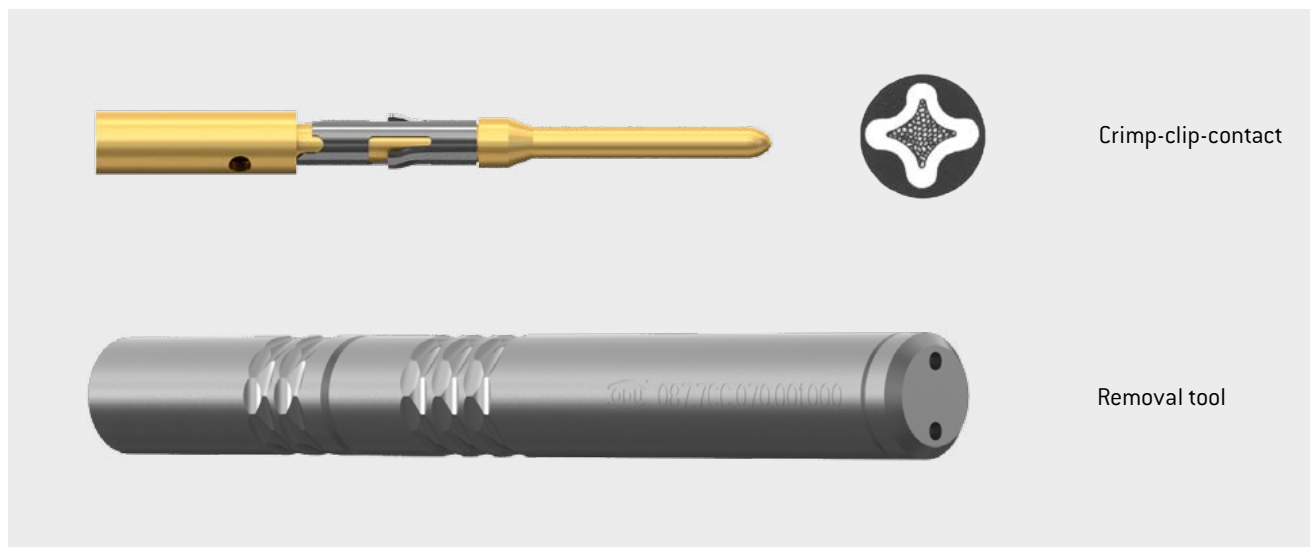

Crimp-clip-contact

Removal tool

Part number	Contact Ø mm
0877CC.070.001.000	0.7
0877CC.090.001.000	0.9
0877CC.130.001.000	1.3
0877CC.160.001.000	1.6

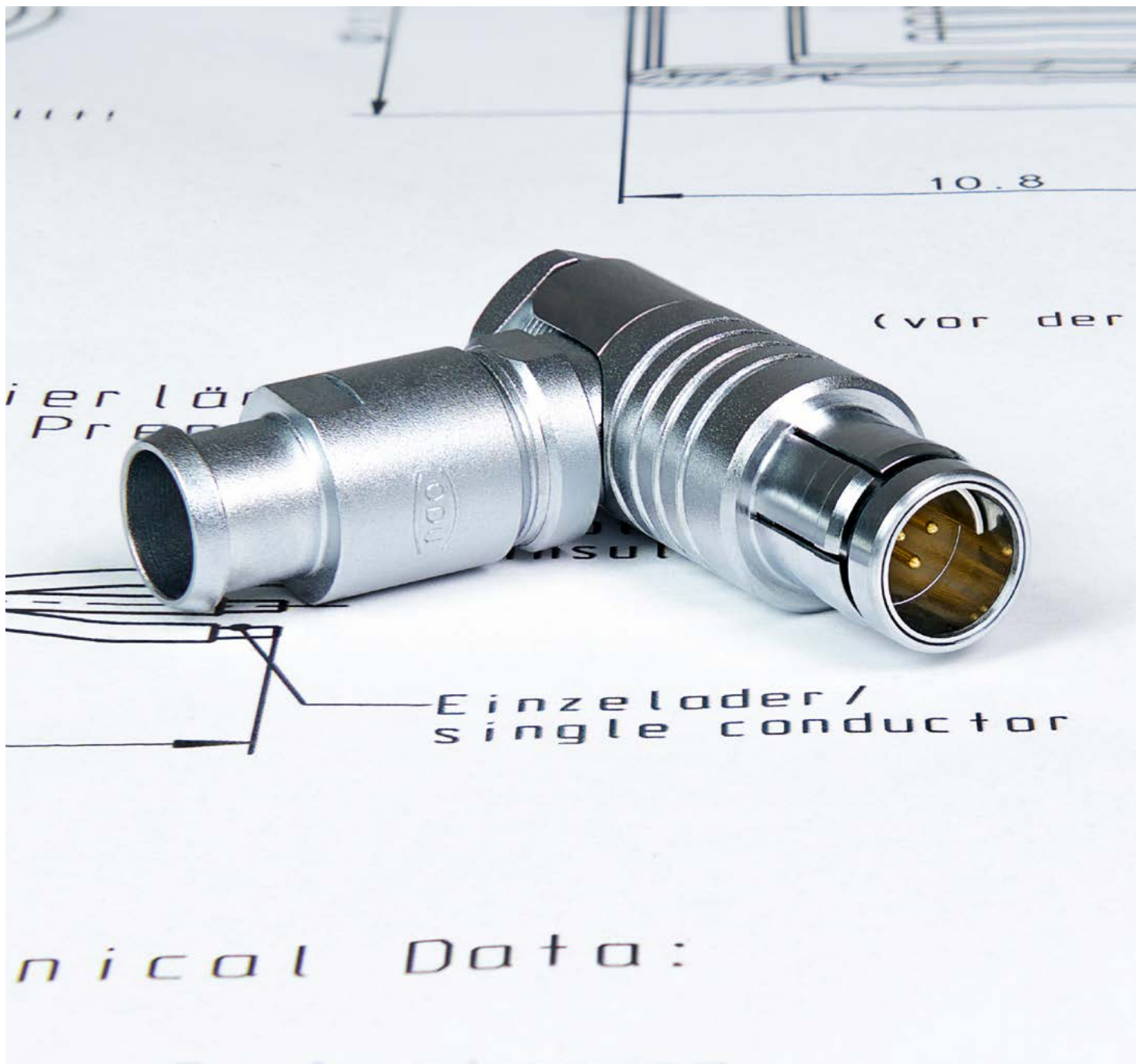

ODU MINI-SNAP®

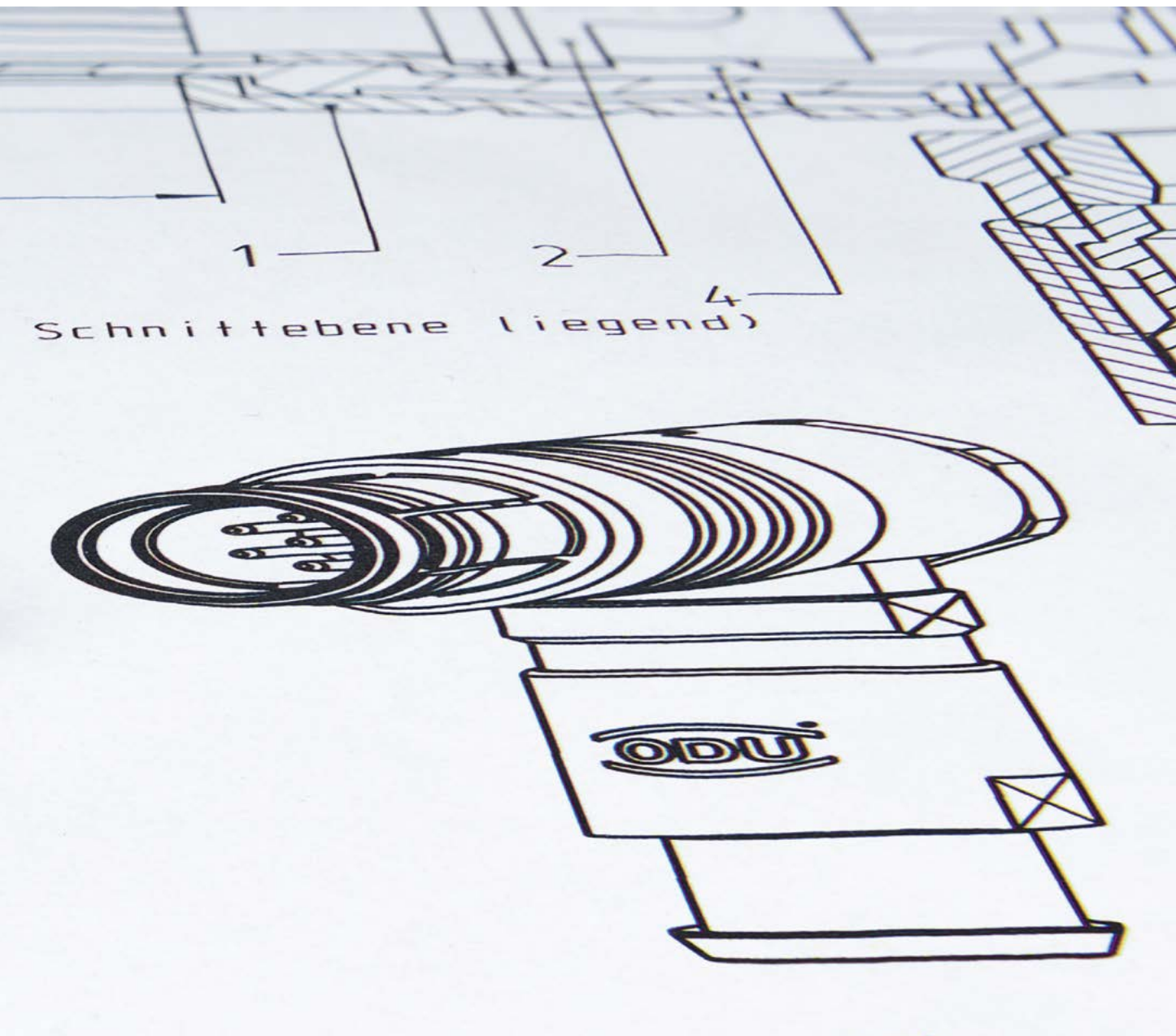

TECHNICAL INFORMATION

ODU connectors ensure perfect and reliable transmission of power, signal, data and other media in a wide variety of applications.

Further information can be found on the following pages.

INTERNATIONAL PROTECTION CLASSES

Acc. IEC 60529:2013 (VDE 0470-1:2014).



Code letters (International Protection)		First code number (Degrees of protection against access to hazardous parts respectively against solid foreign objects)		Second code number (Degrees of protection against water)	
IP		6		5	
Code number	Protection against access to hazardous parts / Protection against ingress of solid foreign objects			Code number	Protection against harmful effects due to the ingress of water
0	No protection		No protection against contact / No protection against solid foreign objects	0	No protection against water
1	Protection against large foreign objects		Protection against contact with the back of the hand / Protection against solid foreign objects $\varnothing \geq 50$ mm	1	Protection against dripping water
2	Protection against medium-sized foreign objects		Protection against contact with the fingers / Protection against solid foreign objects $\varnothing \geq 12.5$ mm	2	Protection against dripping water (tilted)
3	Protection against small foreign objects		Protection against contact with tools / Protection against solid foreign objects $\varnothing \geq 2.5$ mm	3	Protection against spray water
4	Protection against granular foreign objects		Protection against contact with a wire / Protection against solid foreign objects $\varnothing \geq 1.0$ mm	4	Protection against splashing water
5	Dustproof		Protection against contact with a wire / Protection against uncontrolled ingress of dust	5	Protection against water jet
6	Dustproof		Protection against contact with a wire / Complete protection against ingress of dust	6	Protection against powerful water jet
				7	Protection against the effects of temporary immersion in water
				8	Protection against the effects of continuous immersion in water
				9	Schutz gegen Hochdruck und hohe Strahlwassertemperaturen
					Protection against water from all directions by high pressure and high temperatures

PRINCIPLE OF WATERTIGHTNESS WITH ODU MINI-SNAP®

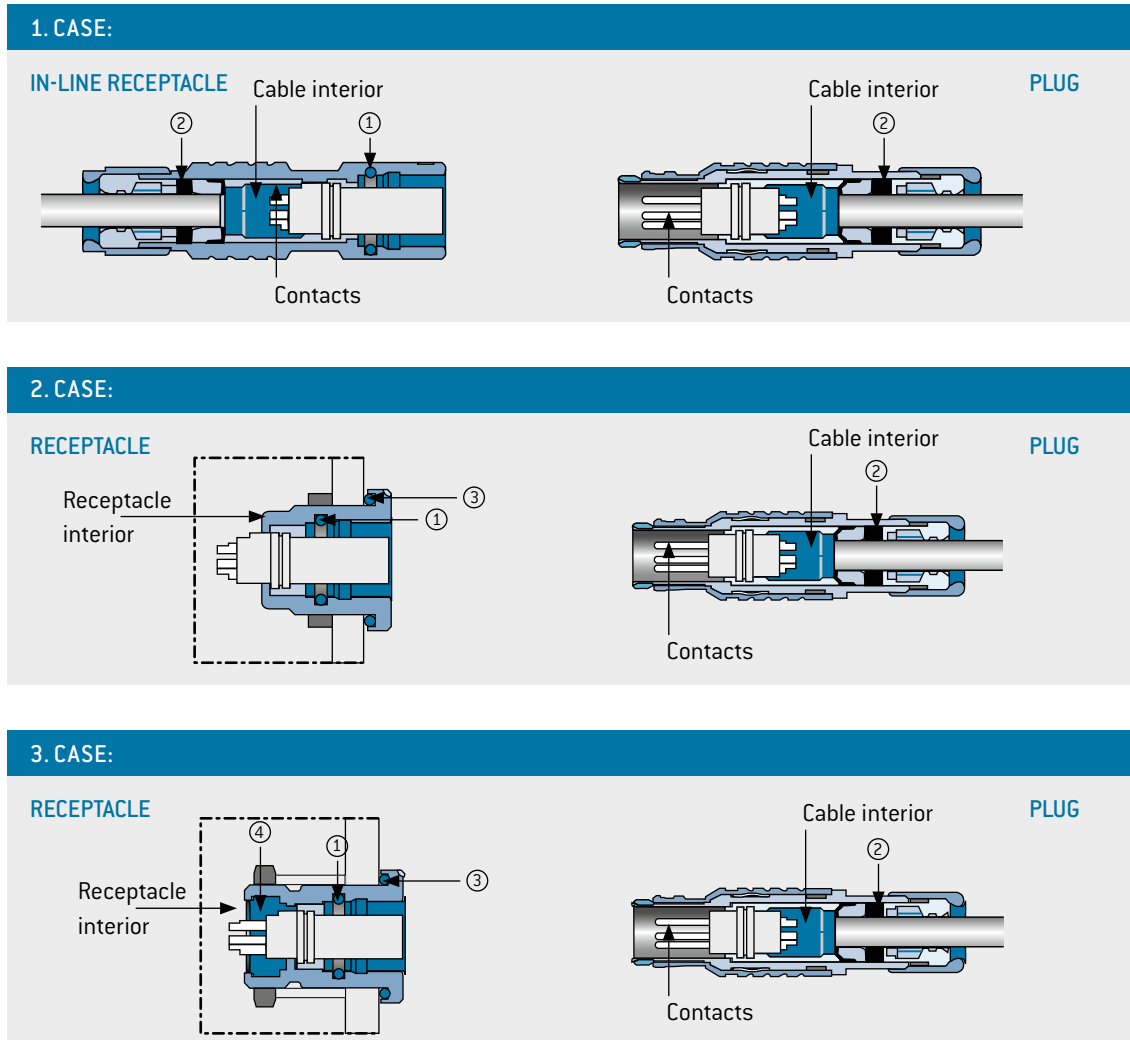

All IP 68 submersible ODU MINI-SNAP connectors have a rated water depth of 2 m [0.2 bar] for 24 hours in accordance with IEC 60529:2013 (VDE 0470-1:2014). A watertight connector requires a sealing in a cable collet system.

The sealing must fit over the cable precisely. The cable jacket must be smooth, cylindrical and free of grooves. The connector should be encapsulated to make it watertight when not mated.

PROTECTION AGAINST WATER BY THE FOLLOWING SEALINGS¹

Case	Termination	Mated		Unmated	
		Tight	Position	Tight	Position
1	Cable interior	Yes	① ②	No	
2	Receptacle interior	Yes	① ② ③	No	
3	Receptacle interior	Yes	① ② ③	Yes	③ ④

① O-ring ② Gasket² ③ O-ring ④ Potting

¹ The following applies to the contacts: the contacts are protected in cases 1, 2 and 3 when mated. When not mated, the contacts are only protected by a protective cover [see page 63 and 64] which must be removed before mating.

² The cable seal with elastic disks requires coordination with the cable. Decisive factors: Diameter tolerance, roundness, cable structure, cable jacket hardness.

HOUSING MATERIALS / SURFACES



Component	Material designation	Surface
Connector plug housing Back nut Round nut	Cu alloy	Cr
Cable collet EMI ring Half-shells Lock washer Nut Retainer ring	Cu alloy	Ni
Contact	Cu alloy	Au

ODU MINI-SNAP connector plug housings are made of brass, nickel plated and then matt chrome plated. Nickel and black chrome plated connector plug housings are available upon request as special materials. The internal parts are made of nickel plated brass.

INSULATOR MATERIALS (ROHS 2011/65/EU COMPLIANT)

	Norm	Unit	PEEK
Dielectric strength	IEC 60243-1:2013	KV/mm	19
Operation temperature	ASTM D-149 :2009	°C	-50/+250
Flammability rating	UL 94: 2013	-	V-0
Comparative tracking index CTI	IEC 60112:2009 (VDE 0303-11:2010)		175

TERMINATION TECHNOLOGIES



Insulators with pin contacts fit into the receptacle (or in-line receptacle) as well as into the plug. The same applies to insulators with socket contacts. In general, insulators with socket contacts are installed in the live part (to provide protection from accidental touch).

The means of mounting the contacts in the insulator is important on account of the termination technologies. Termination technologies for ODU MINI-SNAP connectors include: soldering, crimping and PCB.

SOLDER TERMINATION



CRIMP-CLIP-CONTACT FOR PEEK INSULATOR



PRINT TERMINATION



TERMINATION TECHNOLOGIES FOR TURNED CONTACTS

Solder termination

The contacts are mounted in the insulator before the single conductors are assembled. An insulator with pre-installed contacts is referred to as a contact insert.

Crimp termination

Here, the individual contact is connected to the individual wires via deformation in the termination area. Then the contacts are individually installed in the insulator. Accordingly, insulators and individual contacts – and not complete contact inserts – are supplied for the crimp termination. The contact processing for the production of connecting cables via crimping creates a secure, durable and corrosion-free contact. Cold compaction (crimping) compresses the conductor and contact material to the press points so as to form a gas-tight connection with tensile strength to fit the conductor material. 8-point deformation is generally used for turned crimp contacts.

PCB termination

This is only used in the receptacle or the panel mounted plug in if the receptacle or the panel mounted plug is to be mounted directly on a printed circuit board (PCB). Further information is available upon request.

CONVERSIONS / AWG (AMERICAN WIRE GAUGE)



Circular wire					
AWG	Diameter		Cross-section mm ²	Weight kg / km	Max. resistance Ω / km
	Inch	mm			
10 (1)	0.1019	2.590	5.26	46.77	3.45
10 (37/26)	0.1150	2.921	4.74	42.10	4.13
12 (1)	0.0808	2.050	3.31	29.41	5.45
12 (19/25)	0.0930	2.362	3.08	27.36	6.14
12 (37/28)	0.0910	2.311	2.97	26.45	6.36
14 (1)	0.0641	1.630	2.08	18.51	8.79
14 (19/27)	0.0730	1.854	1.94	17.23	9.94
14 (37/30)	0.0735	1.867	2.08	18.870	10.50
16 (1)	0.0508	1.290	1.31	11.625	13.94
16 (19/29)	0.0590	1.499	1.23	10.928	15.70
18 (1)	0.0403	1.020	0.823	7.316	22.18
18 (19/30)	0.0052	1.321	0.963	8.564	20.40
20 (1)	0.0320	0.813	0.519	4.613	35.10
20 (7/28)	0.0390	0.991	0.563	5.003	34.10
20 (19/32)	0.0420	1.067	0.616	5.473	32.00
22 (1)	0.0253	0.643	0.324	2.883	57.70
22 (7/30)	0.0288	0.732	0.324	2.965	54.80
22 (19/34)	0.0330	0.838	0.382	3.395	51.80
24 (1)	0.0201	0.511	0.205	1.820	91.20
24 (7/32)	0.0250	0.635	0.227	2.016	86.00
24 (19/36)	0.0270	0.686	0.241	2.145	83.30
26 (1)	0.0159	0.404	0.128	1.139	147.00
26 (7/34)	0.0200	0.508	0.141	1.251	140.00
26 (19/38)	0.0220	0.559	0.154	1,370	131.00
28 (1)	0.0126	0.320	0.0804	0.715	231.00
28 (7/36)	0.0160	0.406	0.0889	0.790	224.00
28 (19/40)	0.0170	0.432	0.0925	0.823	207.00
30 (1)	0.0100	0.254	0.0507	0.450	374.00
30 (7/38)	0.0130	0.330	0.0568	0.505	354.00
30 (19/42)	0.0123	0.312	0.0720	0.622	310.00
32 (1)	0.0080	0.203	0.0324	0.288	561.00
32 (7/40)	0.0110	0.279	0.0341	0.303	597.10
32 (19/44)	0.0100	0.254	0.0440	0.356	492.00
34 (1)	0.0063	0.160	0.0201	0.179	951.00
34 (7/42)	0.0070	0.180	0.0222	0.197	1,491.00
36 (1)	0.0050	0.127	0.0127	0.1126	1,519.00
36 (7/44)	0.0060	0.150	0.0142	0.1263	1,322.00

The American Wire Gauge (AWG) is based on the principle that the cross-section of the wire changes by 26% from one gauge number to the next. The AWG numbers decrease as the wire diameter increases, while the AWG numbers increase as the wire diameter decreases. This only applies to solid wire.

However, stranded wire is predominately used in practice. This has the advantage of a longer service life under bending and vibration as well as greater flexibility in comparison with solid wire.

Stranded wires are made of multiple, smaller-gauge wires (higher AWG number). The stranded wire then receives the AWG numbers of a solid wire with the next closest cross-section to that of the stranded wire. In this case, the cross-section of the stranded wire refers to the sum of the copper cross-sections of the individual wires.

Accordingly, strands with the same AWG number but different numbers of wires differ in cross-section. For instance, an AWG 20 strand of 7 AWG 28 wires has a cross-section of 0.563 mm², while an AWG 20 strand of 19 AWG 32 wires has a cross-section of 0.616 mm².

Source: ASTM

CURRENT LOAD OF TURNED CONTACTS



Nominal single contact current load for pin / slotted socket (nominal diameter 0.5 mm – 3.0 mm)

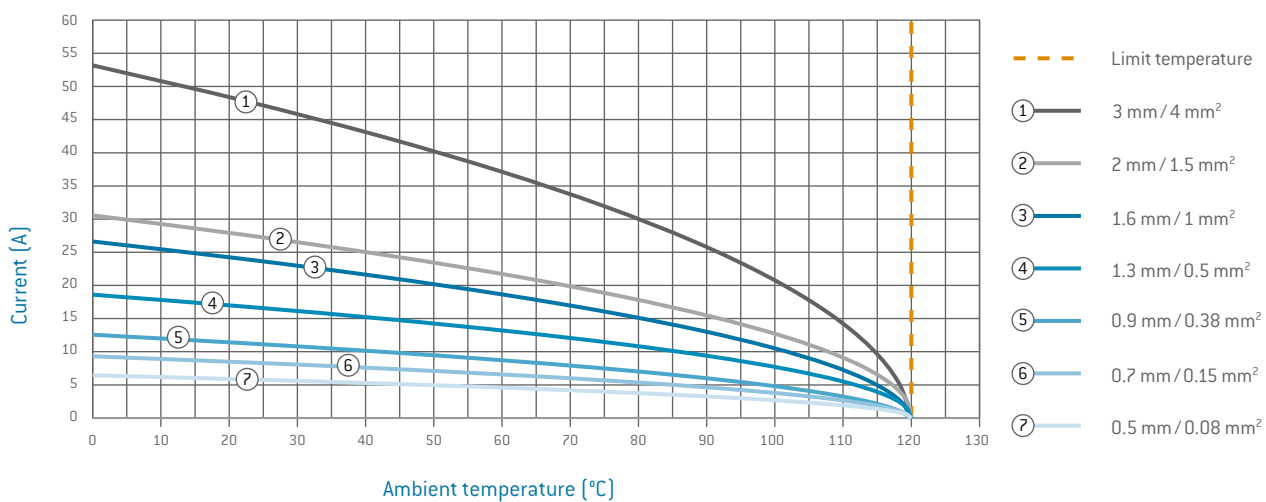
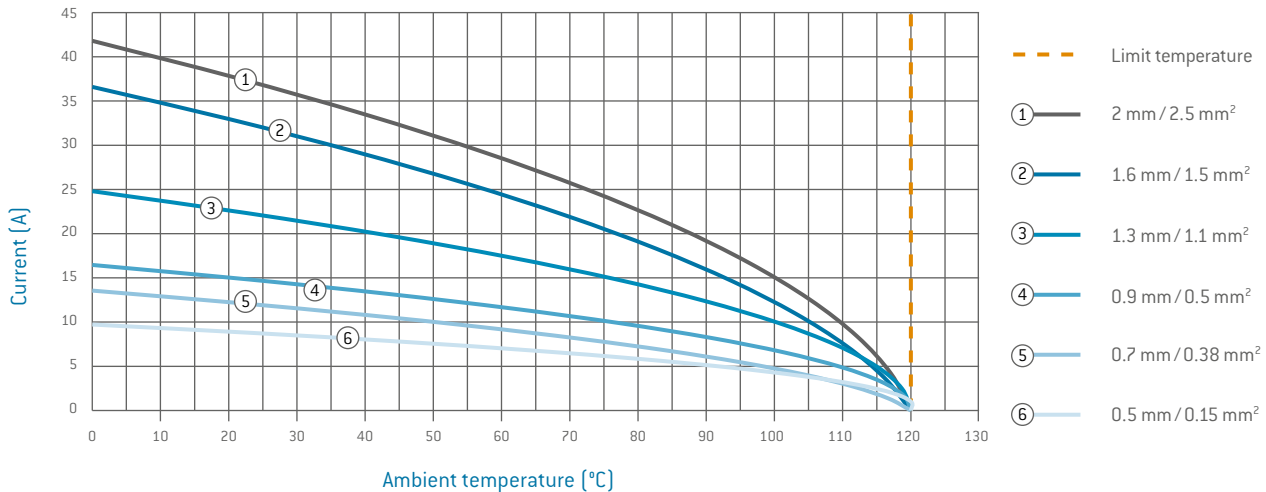

UPPER LIMIT TEMPERATURE OF STANDARD CONTACTS: +120 °C.

The wire cross-section shown in the legend was connected as test cable. In the case of multi-position connectors and cables, the heating is greater than it is with individual contacts. For that reason, it is calculated with a derating factor.

For connectors, the derating factors for multi-core cables pursuant to VDE 0298-4:2013 are applied. The derating factor is factored in at 5 live wires and up.

DERATING CURVE

The corrected current-carrying capacity curve, derived from the base curve determined (0.8 x measured current). It factors in manufacturing tolerances as well as uncertainties in temperature measurement and measurement arrangement. See derating measurement method.

RATED CURRENT (NOMINAL CURRENT)

The metrologically determined current which is permitted to flow continuously through all contacts at the same time and will increase the contact temperature by 45 Kelvin. The amperage is determined according to the derating measurement method (DIN EN 60512-5-2:2002) and derived from the derating curve.

DERATING FACTOR

Number of loaded wires	Derating factor
5	0.75
7	0.65
10	0.55
14	0.5
19	0.45
24	0.4

OPERATING VOLTAGE



Acc. SAE AS 13441:2004 method 3001.1

The values specified in the catalogue correspond to SAE AS 13441:2004 method 3001.1. The table values were determined according to EIA 364-20E: 2015. The inserts were tested while mated, and the test current was applied to the pin insert.

75 % of the dielectric withstanding voltage is used for the further calculation. The operating voltage is 1/3 of this value.

All tests were conducted at normal indoor climate and apply up to an altitude of 2,000 m.

If there are any deviations, the derating factors are to be factored in according to the applicable standards.

Test voltage = Dielectric withstanding voltage \times 0.75

Operating voltage = Dielectric withstanding voltage \times 0.75 \times 0.33

ATTENTION:

With certain applications, the safety requirements for electrical devices are very strict in terms of operating voltage.

In such cases, the operating voltage is defined according to the clearance and creepage distances between parts which could be touched.

When selecting such a connector, please contact us and let us know the safety standard which the product must meet.

Test voltage = Dielectric withstanding voltage \times 0.75

Operating voltage = Dielectric withstanding voltage \times 0.75 \times 0.33

ELECTRO MAGNETIC COMPATIBILITY (EMC)

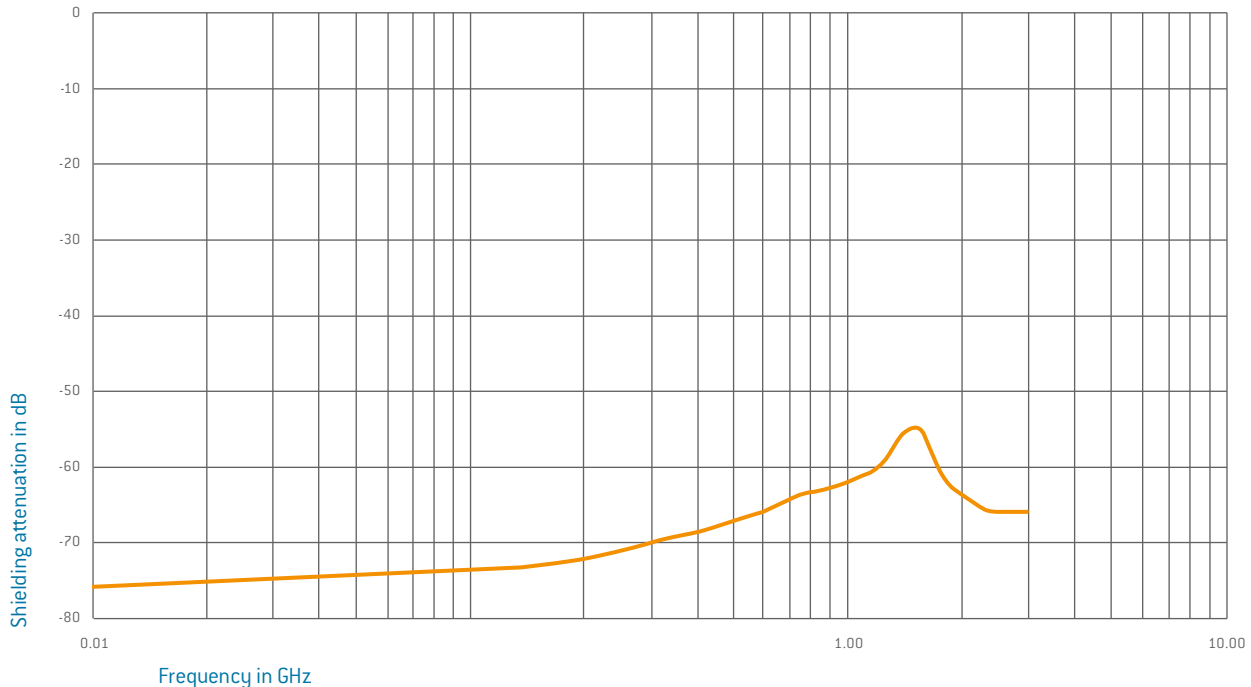

Electromagnetic compatibility (EMC) concerns more than just devices and electronic circuits. In the age of networks and data communication, connecting elements such as cables and connectors are also very important. Interference signals penetrating the connector from outside corrupt data signals and can cause significant system malfunctions. This can be reliably avoided with high-grade shielding for the cables and connectors. In order to give our customers certainty when using ODU MINI-SNAP connectors, we've had a size 3 connector measured by an accredited EMC laboratory to determine its EMC quality. Since the sizes 0, 1 and 2 are identical to this connector in structure, just proportionally reduced in size, the values for shielding attenuation are the same.

The measurement was conducted according to the injection or parallel wire method pursuant to VG 95214-11:2002. The connector pair is connected with to the receiver of a network analyzer on one end, while the other end receives an adjusted termination resistor. The injection wire is attached as closely as possible along the connector pair. A flat cable is usually used here, since an optimum adjustment can be achieved by attaching more or fewer wires. High-frequency signals in the 10 kHz to 3 GHz range are now fed in through the injection wire. The network analyzer measures the energy irradiated through the connector plug housing and into the connector, providing a shielding attenuation factor as the logarithmic performance ratio AT in dB. The important thing with this method is that all supply lines (especially the ones to the connector pair) must be very well shielded so that no interference signals can penetrate the measurement system and corrupt the measured values. This provides the shielding attenuation in dB as a curve over the logarithmically applied frequency.

Users frequently demand a shielding attenuation better than -55 dB (based on a requirement of Deutsche Post). It is clear that our connector meets this requirement over the entire measurement range.

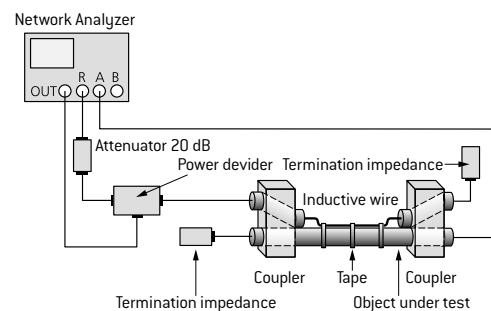

AUTOCLAVING OF ODU MINI-SNAP®



We can also provide ODU MINI-SNAP connectors for the following sterilization procedures upon request: steam sterilization via pre-vacuum or gravity method. The connectors are tested in autoclaves for 500 cycles at 134° C in accordance with DIN EN 13060:2015.

Please consult our technical team for the further sterilization procedure.

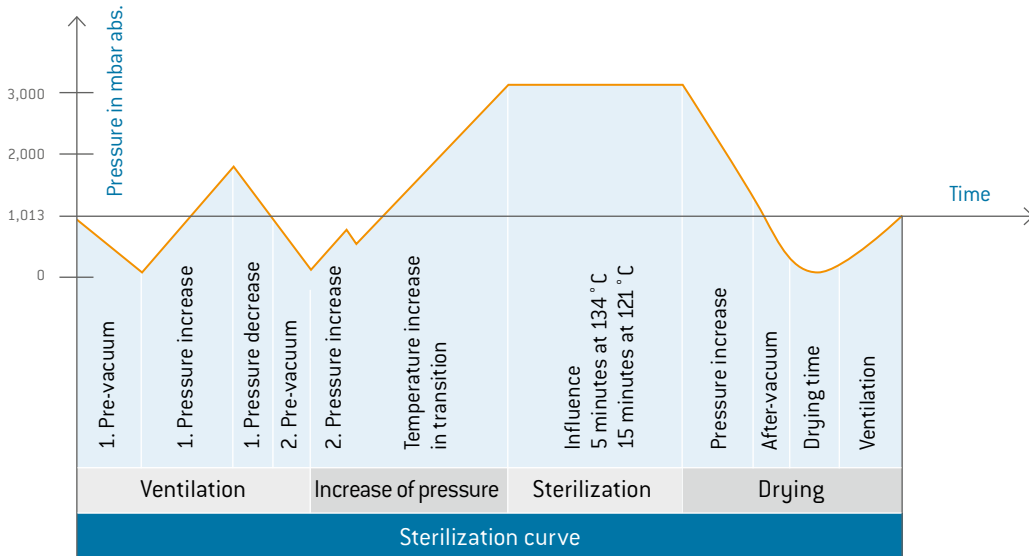

TEST STANDARD

In terms of the quality approval, sizes 0 and 3 were subjected to environmental and mechanical tests pursuant to MIL and passed them flawlessly.

Definition	Standard
High temperature	MIL-STD-810G w/Change 1:2014 method 501
Low temperature	MIL-STD-810G w/Change 1:2014 method 502
Temperature shock	MIL-STD-810G w/Change 1:2014 method 503
Humidity	MIL-STD-810G w/Change 1:2014 method 507
Salt fog	MIL-STD-810G w/Change 1:2014 method 509
Shock	MIL-STD-810G w/Change 1:2014 method 516
Vibration	MIL-STD-1344A method 2005.1 (IV)
Watertightness IP 68	IEC 60529:2013 (VDE 0470-1:2014)

TECHNICAL TERMS



AMBIENT TEMPERATURE

Temperature of the air or other medium in which a piece of equipment is intended to be used in.
(IEC 44/709/CDV:2014 (VDE 0113-1:2014))

AUTOCLAVABILITY

See page [86](#).

AWG

American Wire Gauge (see page [82](#)).

BASE CURVE

A current-carrying capacity curve metrologically determined according to the method described in IEC 60512-5-2:2002 (DIN EN 60512-5-2:2003) depending on the permissible limit temperature of the materials. See page [83](#).

CHEMICAL RESISTANCE

Many secondary processing procedures use adhesives, cleaning agents or other chemicals on our products. Contact with unsuitable chemicals may have an adverse effect on the mechanical and electrical properties of the insulation and housing materials which specified properties may not be able to withstand. Please observe our processing suggestions and technical instructions in this catalogue.

CLEARANCE DISTANCE

The shortest distance in the air between two conductive parts.

CONNECTORS

Also known as connectors without contact rating (COC): (IEC 61984:2008 (VDE 0627:2009)). An element which enables electrical conductors to be connected and is intended to create and/or separate connections with a suitable counterpart.
Also known as connectors without contact rating (COC): (IEC 61984:2008 (VDE 0627:2009)). An element which enables electrical conductors to be connected and is intended to create and/or separate connections with a suitable counterpart.

CONNECTOR WITHOUT BREAKING CAPACITY (COC)

Connector which is not deemed to be engaged or disengaged in normal use when live or under load.

CONTACT RESISTANCE

Total resistance value measured from terminal to terminal. In this case, the resistance is significantly lower than the contact resistance. The specifications are average values.

CORES

Electrical conductor, solid wire or multi-wire strand, with insulation as well as any conductive layers. Cables or leads may have one or more cores.

CREEPAGE DISTANCES

The shortest distance between two conductive parts along the surface of a solid insulation material. This factors in all elevations and recesses in the insulator, as long as defined minimum dimensions are on hand.

CRIMP BARREL

A terminal sleeve which can accommodate one or more conductor and be crimped by a crimping tool.

CRIMP CONNECTION (CRIMP TERMINATION)

The permanent, non-detachable and solder-free mounting of a contact to a conductor via deforming or shaping under pressure to make a good electrical and mechanical connection. Executed with crimping tool, press or automatic crimping machine (see page [72](#)).

CRIMPING AREA

The specified area of the crimp barrel in which the crimp termination is executed by means of deforming or shaping the barrel under pressure around the conductor.

DEGREE OF POLLUTION

The effect of pollution is factored in as degree of pollution when measuring clearance and creepage distances. Four degrees of pollution are defined for the micro-environment: IEC 60664-1:2007 (VDE 0110-1:2008).

DELIVERY FORM

Connectors can be delivered in assembled form or as individual parts.

DERATING CURVE

See page [83](#).

TECHNICAL TERMS



DERATING FACTOR

According to VDE 0298-4:2013, with connectors and cables over 5 contacts, the heating is greater than it is with individual contacts. For that reason, the aforementioned standard is calculated with a derating factor.

DERATING MEASUREMENT METHOD IEC 60512-5-2:2002 (DIN EN 60512-5-2:2003)

Measurement method to determine the current-carrying capacity of connectors in consideration of the maximum permissible limit temperature (see page [83](#)).

FIXED CONNECTORS

Intended for mounting on a fixed surface such as a frame, dock, device or wall (with ODU also receptacle or panel mounted plug).

FREE CONNECTORS

Intended for mounting on free ends of mobile leads and cables (with ODU also connectors, plugs, in-line receptacles).

INSULATOR

Part of a connector which separates conductive parts with different potentials from one another; usually identical to the contact carrier.

KEYING (ORIENTATION)

Arrangement with which differing polarization of otherwise identical connectors prevents interchangeability. This is a good idea if two or more identical connectors are attached to the same device (see also compatible connectors, see page [42](#)).

LOWERMOST LIMIT TEMPERATURE

The lowest permissible temperature at which a connector may be operated. At ODU MINI-SNAP, it amounts to -40°C .

MATERIALS (STANDARD MODEL)

See page [80](#).

MATING AND DEMATING FORCE

The force required to fully mate or demate pluggable elements without the influence of a coupling or locking device.

MATING CYCLES

Mechanical actuation of connectors via push and pull action. A mating cycle consists of one mating and demating action. ODU's standard value for the ODU MINI-SNAP series is 5,000 mating cycles.

MAX. CONTINUOUS CURRENT

The metrologically determined amperage at room temperature (approx. 20°C) which increases the contact temperature to the limit temperature. The values specified in the catalog apply to either individual contacts or completely assembled inserts / modules, as indicated.

NOMINAL SINGLE CONTACT CURRENT LOAD

The current-carrying capacity which each individual contact can be loaded with on its own (see page [83](#)).

NOMINAL VOLTAGE

The voltage which the manufacturer specifies for a connector and which the operating and performance features relate to.

OPERATING TEMPERATURE FOR ODU MINI-SNAP

Range between the uppermost and lowermost temperature limits. -40°C to $+120^{\circ}\text{C}$ (see page [15](#)).

PCB (A.K.A. "PRINTED CIRCUIT BOARD")

A PCB is a carrier for electronic components. It serves the purposes of mechanical mounting and electrical connection.

PCB TERMINATION

Production of a conductive connection between the PCB and an element in through-hole assembly, THT (through-hole technology).

RATED CURRENT (NOMINAL CURRENT)

See page [83](#).

RATED VOLTAGE

According to DIN EN 60664-1 standard "Value of a voltage which is specified by the manufacturer for a component, device or operating medium and relates to the operating and performance features."

TECHNICAL TERMS



SOLDER CONNECTION (SOLDER TERMINATION)

Termination technology in which a molten additional metal (solder) with a lower melting point than the base materials to be connected is used to attach two metallic materials to one another.

TIGHTNESS IEC 60529:2013 (VDE 0470-1:2014)

See protection classes on page [79](#).

TERMINATION CROSS-SECTION

The specified cross-sections correspond to a “fine-wire” conductor structure pursuant to DIN EN 60228:2005 (VDE 0295:2005; class 5) or a “fine-wire” conductor structure (7/19 wire) according to AWG (ASTM B258:2014).

TERMINATION TECHNOLOGIES

Methods for connecting the leads to the electro-mechanical element, such as solder-free connections pursuant to IEC 60352 (DIN EN 60352): crimp, screw connection etc. or soldering connection (see page [ÜS](#)).

TEST VOLTAGE

The voltage which a conductor can withstand under defined conditions without dielectric breakdown or flashover.

UPPERMOST LIMIT TEMPERATURE

The maximum permissible temperature at which a connector may be operated. It includes contact heating through current-carrying capacity.

With ODU MINI-SNAP Standard TURNTAC contacts, it amounts to +120° C. Please consult ODU for high-temperature applications.

WIRE

Wires (solid conductors) are available with an insulator sleeve and/or electrical shielding. Cables or conductors may be made up of one or more wires.

GENERAL NOTE

The connectors listed in this catalogue are intended for use in high voltage and frequency ranges. Suitable precautionary measures must be taken to ensure that people do not come into contact with live conductors during installation and operation.

All entries in this catalogue were thoroughly reviewed before printing. ODU reserves the right to make changes based on the current state of knowledge without prior notice without being obliged to provide replacement deliveries or refinements of older designs.

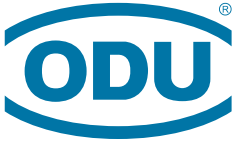

A PERFECT ALLIANCE.

ODU GROUP WORLDWIDE

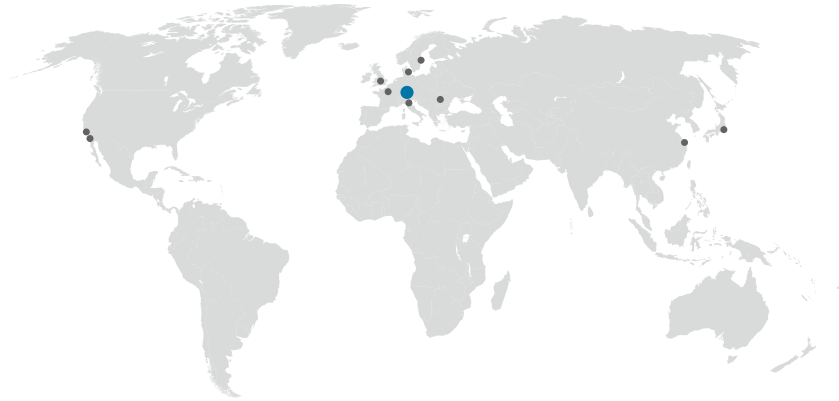

ODU USA

ODU-USA, Inc.

300 Camarillo Ranch Road, Suite A, Camarillo, CA 93012, United States of America
Phone: +1 805 484-0540, Fax: +1 805 484-7458, E-mail: sales@odu-usa.com

HEADQUARTERS

ODU GmbH & Co. KG

Pregelstraße 11
84453 Mühldorf a. Inn, Germany
Phone: +49 8631 6156-0
Fax: +49 8631 6156-49
E-mail: zentral@odu.de
www.odu.de

PRODUCTION AND LOGISTICS SITES

Germany	Otto Dunkel GmbH
China	ODU (Shanghai) Connectors Manufacturing Co.Ltd
Mexico	ODU Mexico Manufacturing S.R.L. de C.V.
Romania	ODU Romania Manufacturing S.R.L.
USA	ODU-USA, Inc. ODU North American Logistics

FURTHER SALES SUBSIDIARIES

ODU Denmark ApS

Phone: +45 2233 5335
E-mail: sales@odu-denmark.dk
www.odu-denmark.dk

ODU France SARL

Phone: +33 1 3935-4690
E-mail: odu@odu.fr
www.odu.fr

ODU Italia S.R.L.

Phone: +39 331 8708847
E-mail: sales@odu-italia.it
www.odu-italia.it

ODU Japan K.K.

Phone: +81 3 6441 3210
E-mail: sales@odu.co.jp
www.odu.co.jp

ODU Scandinavia AB

Phone: +46 176 18262
E-mail: sales@odu.se
www.odu.se

ODU (Shanghai)

International Trading Co., Ltd.
Phone: +86 21 58347828-0
E-mail: oduchina@odu.com.cn
www.odu.com.cn

ODU-UK Ltd.

Phone: +44 330 002 0640
E-mail: sales@odu-uk.co.uk
www.odu-uk.co.uk

**Further information and specialized
representatives can be found at:**
www.odu-usa.com/contact



Simply scan the QR code
to download the entire brochure.

KOMMA Werbeagentur | D-84453 Mühldorf a. Inn

ODU MINI-SNAFF / B / 0518 / E

Mouser Electronics

Authorized Distributor

Click to View Pricing, Inventory, Delivery & Lifecycle Information:

ODU USA:

[G10F1C-P02LJG0-0000](#) [G10F1C-P04LFG0-0000](#) [G11F1C-P02LPH0-0000](#) [G11F1C-P03LPH0-0000](#) [G11F1C-P04LJG0-0000](#) [G11F1C-P05LJG0-0000](#) [G11F1C-P06LFG0-0000](#) [G11F1C-P07LFG0-0000](#) [G11F1C-P08LFG0-0000](#) [G11F1C-P12LCC0-0000](#) [G12F1C-P03LSN0-0000](#) [G12F1C-P05LPH0-0000](#) [G12F1C-P11LJG0-0000](#) [G12F1C-P19LFG0-0000](#) [G13F1C-P02LVT0-0000](#) [G13F1C-P18LJG0-0000](#) [G13F1C-P27LFG0-0000](#) [G1AF1C-P10LFG0-0000](#) [G1AF1C-P12LFG0-0000](#) [G50F1C-P02LJG0-0000](#) [G50F1C-P04LFG0-0000](#) [G51F1C-P02LPH0-0000](#) [G51F1C-P03LPH0-0000](#) [G51F1C-P04LJG0-0000](#) [G51F1C-P05LJG0-0000](#) [G51F1C-P06LFG0-0000](#) [G51F1C-P06MFG0-0000](#) [G51F1C-P07LFG0-0000](#) [G51F1C-P08LFG0-0000](#) [G51F1C-P12LCC0-0000](#) [G52F1C-P03LSN0-0000](#) [G52F1C-P05LPH0-0000](#) [G52F1C-P11LJG0-0000](#) [G52F1C-P16LFG0-0000](#) [G52F1C-P19LFG0-0000](#) [G52F1C-P19QF00-0000](#) [G52F2C-P11QJ00-0000](#) [G53F1C-P02LVT0-0000](#) [G53F1C-P12LPH0-0000](#) [G53F1C-P16QM00-0000](#) [G53F1C-P18LJG0-0000](#) [G53F1C-P27LFG0-0000](#) [G53F1C-P27QF00-0000](#) [G53F1C-P27QF00-A000](#) [G53F2C-P24QF00-0000](#) [G53F2C-P27LFG0-0000](#) [G5AF1C-P10LFG0-0000](#) [G5AF1C-P12LFG0-0000](#) [G5AF1C-P19LCC0-0000](#) [G80F1C-P02LJG0-0000](#) [G80F1C-P04LFG0-0000](#) [G80F1C-P07QC00-0000](#) [G80F1C-P07RC00-0000](#) [G80F2C-P02RJ00-0000](#) [G81F1C-P02LPH0-0000](#) [G81F1C-P03LPH0-0000](#) [G81F1C-P04LJG0-0000](#) [G81F1C-P05LJG0-0000](#) [G81F1C-P06LFG0-0000](#) [G81F1C-P07LFG0-0000](#) [G81F1C-P07QF00-0000](#) [G81F1C-P08LFG0-0000](#) [G81F1C-P12LCC0-0000](#) [G81F1C-P12QC00-0000](#) [G82F1C-P03LSN0-0000](#) [G82F1C-P05LPH0-0000](#) [G82F1C-P11LJG0-0000](#) [G82F1C-P19LFG0-0000](#) [G83F1C-P02LVT0-0000](#) [G83F1C-P12LPH0-0000](#) [G83F1C-P18LJG0-0000](#) [G83F1C-P27LFG0-0000](#) [G8AF1C-P10LFG0-0000](#) [G8AF1C-P12LFG0-0000](#) [G8AF1C-P12QF00-0000](#) [G8AF1C-P19LCC0-0000](#) [K10F1C-P02LJG0-1500](#) [K10F1C-P02LJG0-2000](#) [K10F1C-P02LJG0-2500](#) [K10F1C-P02LJG0-3000](#) [K10F1C-P02LJG0-3500](#) [K10F1C-P02LJG0-4000](#) [K10F1C-P02LJG0-4500](#) [K10F1C-P02LJG0-5000](#) [K10F1C-P03LJG0-1500](#) [K10F1C-P03LJG0-2000](#) [K10F1C-P03LJG0-2500](#) [K10F1C-P03LJG0-3500](#) [K10F1C-P04LFG0-1500](#) [K10F1C-P04LFG0-2000](#) [K10F1C-P04LFG0-2500](#) [K10F1C-P04LFG0-3000](#) [K10F1C-P04LFG0-3500](#) [K10F1C-P04LFG0-4000](#) [K10F1C-P04LFG0-4500](#) [K10F1C-P05LFG0-1500](#) [K10F1C-P05LFG0-2000](#) [K10F1C-P05LFG0-2500](#) [K10F1C-P05LFG0-3000](#) [K10F1C-P05LFG0-3500](#)