

90V Ceramic Gas Discharge Tubes

1. Features

- FeatureNon-Radioactive
- SMD Device
- ROHS Compliant
- High insulation resistance
- LOW Capacitance
- Fast response-time
- Extremely small size

2. Applications

- PON protection
- Consumer electronic
- PCI Cards protection
- XDSL Splitter
- Telephone/Fax/modem protection
- Electrostatic charge elimination
- Date/Single line protection

3. Product characteristics

Part Number	Physical dimensions	Packing	Quantity per reel	Reel Size
4532-091-LF(ES)	4.5mm*3.2mm*2.7mm	Tape	2500 PCS	13 inches

Table-1 Ordering information

4. Electrical Characteristics

Part number	DC spark-over Voltage	Impulse spark-over Voltage	Impulse Discharge current		AC discharge current 50Hz	Electrode Capacitance	Insulation resistance	DC Holdover voltage
	100V/S	1 KV/μs	8/20 μs ± 5 times	10/1000μs 5A	1S,5 times	1MHz		
4532-091-LF(ES)	90V ±20%	<600V	2KA	100 times	2A	<0.5pF	>1GR	52V

Notes:

- 1、 Insulation resistance measure at:
DC 50V for the 4532-091-LF(ES) DC 100V for other.
- 2、 Terms in accordance with ITU-T K. 12 and GB/T 9043-2008
- 3、 At delivery AQL 0.65 level II DIN ISO 2859

5. Dimension

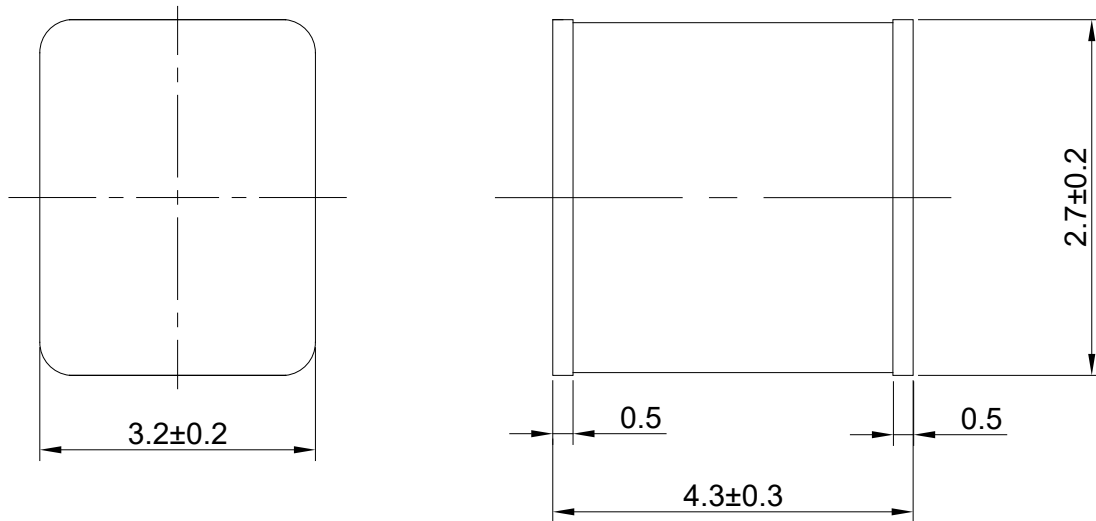

Dimensions in mm.

6. Braidtype

D(mm)	D1(mm)	W1(mm)	QTY: 2500PCS
330	10	12	

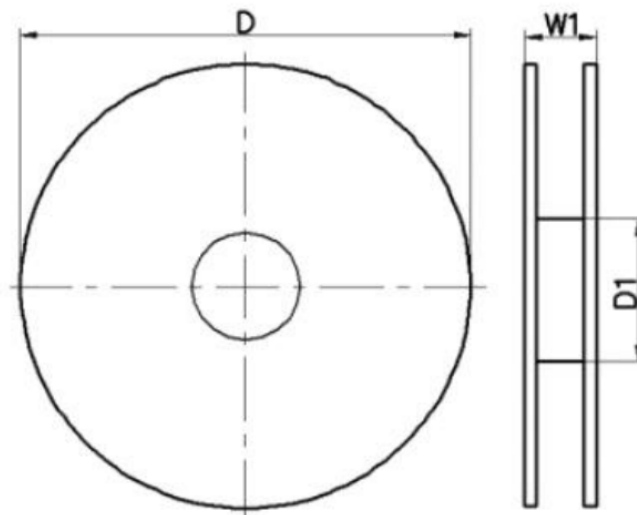

DISCLAIMER

ELECSUER PROVIDES TECHNICAL AND RELIABILITY DATA (INCLUDING DATASHEETS), DESIGN RESOURCES (INCLUDING REFERENCE DESIGNS), APPLICATION OR OTHER DESIGN ADVICE, SAFETY INFORMATION, AND OTHER RESOURCES "AS IS" AND WITH ALL FAULTS, AND DISCLAIMS ALL WARRANTIES, EXPRESS AND IMPLIED, INCLUDING WITHOUT LIMITATION ANY IMPLIED WARRANTIES OF MERCHANTABILITY, FITNESS FOR A PARTICULAR PURPOSE OR NON-INFRINGEMENT OF THIRD PARTY INTELLECTUAL PROPERTY RIGHTS.

These resources are intended for skilled developers designing with ElecSuper products. You are solely responsible for

- (1) selecting the appropriate ElecSuper products for your application;
- (2) designing, validating and testing your application;
- (3) ensuring your application meets applicable standards, and any other safety, security, or other requirements.

These resources are subject to change without notice. ElecSuper grants you permission to use these resources only for development of an application that uses the ElecSuper products described in the resource. Other reproduction and display of these resources are prohibited. No license is granted to any other ElecSuper intellectual property right or to any third party intellectual property right. ElecSuper disclaims responsibility for, and you will fully indemnify ElecSuper and its representatives against, any claims, damages, costs, losses, and liabilities arising out of your use of these resources. ElecSuper's products are provided subject to ElecSuper's Terms of Sale or other applicable terms available either on www.elecsuper.com or provided in conjunction with such ElecSuper products. ElecSuper's provision of these resources does not expand or otherwise alter ElecSuper's applicable warranties or warranty disclaimers for ElecSuper products.