



## R1QAA3636CBG / R1QAA3618CBG / R1QAA3609CBG R1QDA3636CBG / R1QDA3618CBG / R1QDA3609CBG

### 36-Mbit QDR™II+ SRAM 4-word Burst

Rev. 0.08a  
2011.05.23

#### Description

The R1Q#A3636 is a 1,048,576-word by 36-bit, the R1Q#A3618 is a 2,097,152-word by 18-bit, and the R1Q#A3609 is a 4,194,304-word by 9-bit synchronous quad data rate static RAM fabricated with advanced CMOS technology using full CMOS six-transistor memory cell. It integrates unique synchronous peripheral circuitry and a burst counter. All input registers are controlled by an input clock pair (K and /K) and are latched on the positive edge of K and /K. These products are suitable for applications which require synchronous operation, high speed, low voltage, high density and wide bit configuration. These products are packaged in 165-pin plastic FBGA package.

# = A: Read Latency =2.5, w/o ODT

# = D: Read Latency =2.5, w/ ODT

#### Features

- Power Supply
  - 1.8 V for core ( $V_{DD}$ ), 1.4 V to  $V_{DD}$  for I/O ( $V_{DDQ}$ )
- Clock
  - Fast clock cycle time for high bandwidth
  - Two input clocks (K and /K) for precise DDR timing at clock rising edges only
  - Two output echo clocks (CQ and /CQ) simplify data capture in high-speed systems
  - Clock-stop capability with  $\mu$ s restart
- I/O
  - Separate independent read and write data ports with concurrent transactions
  - 100% bus utilization DDR read and write operation
  - HSTL I/O
  - User programmable output impedance
  - DLL circuitry for wide output data valid window and future frequency scaling
  - Data valid pin (QVLD) to indicate valid data on the output
- Function
  - Four-tick burst for reduced address frequency
  - Internally self-timed write control
  - Simple control logic for easy depth expansion
  - JTAG 1149.1 compatible test access port
- Package
  - 165 FBGA package (15 x 17 x 1.4 mm)

Notes: 1. QDR RAMs and Quad Data Rate RAMs comprise a new family of products developed by Cypress Semiconductor, IDT, Samsung, and Renesas Electronics Corp. (QDR Co-Development Team)  
 2. The specifications of this device are subject to change without notice. Please contact your nearest Renesas Electronics Sales Office regarding specifications.  
 3. Refer to  
["http://www.renesas.com/products/memory/fast\\_sram/qdr\\_sram/qdr\\_sram\\_root.jsp"](http://www.renesas.com/products/memory/fast_sram/qdr_sram/qdr_sram_root.jsp)  
 for the latest and detailed information.

## Ordering Information

### Part Number Definition Table

No.	0	1	2	3	4	5	6	7	8	9	10	11	-	12	13	14	15	16
Example	R	1	Q	A	A	7	2	3	6	A	B	G	-	2	0	R	B	0

No.	-	Comments	No.	-	Comments	No.	-	Comments
0-1	R1	Renesas Memory Prefix	4	A	Vdd = 1.8 V			
2-3	Q2	QDR II B2 <sup>[*1]</sup> (L15) <sup>[*2]</sup>	5-6	36	Density = 36Mb	12-13	60	Frequency = 167MHz
	Q3	QDR II B4 (L15)		72	Density = 72Mb		50	Frequency = 200MHz
	Q4	DDR II B2 (L15)		44	Density = 144Mb		40	Frequency = 250MHz
	Q5	DDR II B4 (L15)		88	Density = 288Mb		36	Frequency = 275MHz
	Q6	DDR II B2 SIO <sup>[*3]</sup> (L15)	7-8	09	Data width = 9bit		33	Frequency = 300MHz
	QA	QDR II+ B4 L25 <sup>[*2]</sup>		18	Data width = 18bit		30	Frequency = 333MHz
	QB	DDR II+ B2 L25	9	36	Data width = 36bit		27	Frequency = 375MHz
	QC	DDR II+ B4 L25		R	1st Generation		25	Frequency = 400MHz
	QD	QDR II+ B4 L25 w/ODT <sup>[*4]</sup>		A	2nd Generation		22	Frequency = 450MHz
	QE	DDR II+ B2 L25 w/ODT		B	3rd Generation		20	Frequency = 500MHz
	QF	DDR II+ B4 L25 w/ODT		C	4th Generation	19	Frequency = 533MHz	
	QG	QDR II+ B4 L20		D	5th Generation	14	R	Commercial temp. Ta range = 0°C~70°C
	QH	DDR II+ B2 L20	E	6th Generation	I		Industrial temp. Ta range = -40°C~85°C	
	QJ	DDR II+ B4 L20	F	7th Generation	15		A	Pb and Tray
	QK	QDR II+ B4 L20 w/ODT	BG	PKG= BGA 15x17 mm			B	Pb-free and Tray
	QL	DDR II+ B2 L20 w/ODT	BA	PKG= BGA 13x15 mm		T	Pb and Tape&Reel	
QM	DDR II+ B4 L20 w/ODT	10-11			S	Pb-free and Tape&Reel		
QN	QDR II+ B2 L20				16	0~9, A~Z or None	Renesas internal use	
QP	QDR II+ B2 L20 w/ODT							

Note1: [\*1] B=Burst length (B2: Burst length=2, B4: Burst length=4)  
 [\*2] L=Read Latency (L15: Read Latency = 1.5 cycle, L20: 2.0 cycle, L25: 2.5 cycle)  
 [\*3] SIO=Separate I/O  
 [\*4] ODT=On die termination

Note2: Package Marking Name  
 Pb parts: Marking Name = Part Number (0-14)  
 Pb-free parts: Marking Name = Part Number (0-14) + "PB-F"  
 (Example) R1QAA7236ABG-20R ----- Pb parts  
 R1QAA7236ABG-20R PB-F ----- Pb-free parts

Note3: Pb : RoHS Compliance Level = 5/6  
 Pb-free: RoHS Compliance Level = 6/6

### Generation Number Table

Density	Type	Generation Number <sup>*1</sup>	Notes
36Mb	II+	C	1, 2
72Mb	II & II+	A	1, 2
144Mb	II & II+	R	1
288Mb	II & II+	R	1

Notes:  
 1. As of the day when this datasheet was issued.  
 2. Both "Commercial" and "Industrial" temperatures are supported by "Industrial" temperature version.

**R1QAA36\*\*CB\* / R1QDA36\*\*CB\* Series**

**Speed Bin Table**

No	Product Type	Burst Length	Latency (Cycle)	ODT	Organi- zation	Frequency (max) (MHz)		QDR II+ / DDR II+						QDR II / DDR II			
						Cycle Time (min) (ns)		533	500	450	400	375	333	333	300	250	200
						Part Number ↓	yy →	-19	-20	-22	-25	-27	-30	-30	-33	-40	-50
17	QDRII+	B4	2.5	No	x18	R1Q A A36 18 CBv-yy	-19	-20	-22								
18					x36	R1Q A A36 36 CBv-yy											
20	DDRII+	B2			x18	R1Q B A36 18 CBv-yy	-19	-20	-22								
21					x36	R1Q B A36 36 CBv-yy											
23		B4			x18	R1Q C A36 18 CBv-yy	-19	-20	-22								
24					x36	R1Q C A36 36 CBv-yy											
26	QDRII+	B4	x18	R1Q D A36 18 CBv-yy	-19	-20	-22										
27			x36	R1Q D A36 36 CBv-yy													
29	DDRII+	B2	x18	R1Q E A36 18 CBv-yy	-19	-20	-22										
30			x36	R1Q E A36 36 CBv-yy													
32		B4	x18	R1Q F A36 18 CBv-yy	-19	-20	-22										
33			x36	R1Q F A36 36 CBv-yy													
35	QDRII+	B4	2.0	No	x18	R1Q G A36 18 CBv-yy											
36					x36	R1Q G A36 36 CBv-yy											
38	DDRII+	B2			x18	R1Q H A36 18 CBv-yy											
39					x36	R1Q H A36 36 CBv-yy											
41		B4			x18	R1Q J A36 18 CBv-yy											
42					x36	R1Q J A36 36 CBv-yy											
44	QDRII+	B4			x18	R1Q K A36 18 CBv-yy											
45					x36	R1Q K A36 36 CBv-yy											
47	DDRII+	B2			x18	R1Q L A36 18 CBv-yy											
48					x36	R1Q L A36 36 CBv-yy											
50		B4			x18	R1Q M A36 18 CBv-yy											
51					x36	R1Q M A36 36 CBv-yy											

Notes:

- "yy" represents the speed bin. "R1QAA3636CBG-20" can operate at 500 MHz(max) of frequency, for example.
- "v" represents the package size. If "v" = "G" then size is 15 x 17 mm, and if "v" = "A" then 13 x 15 mm.

Pin Arrangement

R1Q3A3636 (Top) / R1QA(G)A3636 (Mid) / R1QD(K)A3636 (Bottom)

	1	2	3	4	5	6	7	8	9	10	11
A	/CQ	NC	NC	/W	/BW2	/K	/BW1	/R	SA	NC	CQ
B	Q27	Q18	D18	SA	/BW3	K	/BW0	SA	D17	Q17	Q8
C	D27	Q28	D19	V <sub>SS</sub>	SA	NC	SA	V <sub>SS</sub>	D16	Q7	D8
D	D28	D20	Q19	V <sub>SS</sub>	V <sub>SS</sub>	V <sub>SS</sub>	V <sub>SS</sub>	V <sub>SS</sub>	Q16	D15	D7
E	Q29	D29	Q20	V <sub>DDQ</sub>	V <sub>SS</sub>	V <sub>SS</sub>	V <sub>SS</sub>	V <sub>DDQ</sub>	Q15	D6	Q6
F	Q30	Q21	D21	V <sub>DDQ</sub>	V <sub>DD</sub>	V <sub>SS</sub>	V <sub>DD</sub>	V <sub>DDQ</sub>	D14	Q14	Q5
G	D30	D22	Q22	V <sub>DDQ</sub>	V <sub>DD</sub>	V <sub>SS</sub>	V <sub>DD</sub>	V <sub>DDQ</sub>	Q13	D13	D5
H	/DOFF	V <sub>REF</sub>	V <sub>DDQ</sub>	V <sub>DDQ</sub>	V <sub>DD</sub>	V <sub>SS</sub>	V <sub>DD</sub>	V <sub>DDQ</sub>	V <sub>DDQ</sub>	V <sub>REF</sub>	ZQ
J	D31	Q31	D23	V <sub>DDQ</sub>	V <sub>DD</sub>	V <sub>SS</sub>	V <sub>DD</sub>	V <sub>DDQ</sub>	D12	Q4	D4
K	Q32	D32	Q23	V <sub>DDQ</sub>	V <sub>DD</sub>	V <sub>SS</sub>	V <sub>DD</sub>	V <sub>DDQ</sub>	Q12	D3	Q3
L	Q33	Q24	D24	V <sub>DDQ</sub>	V <sub>SS</sub>	V <sub>SS</sub>	V <sub>SS</sub>	V <sub>DDQ</sub>	D11	Q11	Q2
M	D33	Q34	D25	V <sub>SS</sub>	V <sub>SS</sub>	V <sub>SS</sub>	V <sub>SS</sub>	V <sub>SS</sub>	D10	Q1	D2
N	D34	D26	Q25	V <sub>SS</sub>	SA	SA	SA	V <sub>SS</sub>	Q10	D9	D1
P	Q35	D35	Q26	SA	SA	C QVLD QVLD	SA	SA	Q9	D0	Q0
R	TDO	TCK	SA	SA	SA	/C NC ODT	SA	SA	SA	TMS	TDI

(Top View)

Top ←R1Q3A3636  
 Mid ←R1QA(G)A3636  
 Bottom ←R1QD(K)A3636

- Notes: 1. Address expansion order for future higher density SRAMs: 10A → 2A → 7A → 5B.  
 2. NC pins can be left floating or connected to 0V ~ V<sub>DDQ</sub>.

R1Q3A3618 (Top) / R1QA(G)A3618 (Mid) / R1QD(K)A3618 (Bottom)

	1	2	3	4	5	6	7	8	9	10	11
A	/CQ	NC	SA	/W	/BW1	/K	NC	/R	SA	NC	CQ
B	NC	Q9	D9	SA	NC	K	/BW0	SA	NC	NC	Q8
C	NC	NC	D10	V <sub>SS</sub>	SA	NC	SA	V <sub>SS</sub>	NC	Q7	D8
D	NC	D11	Q10	V <sub>SS</sub>	V <sub>SS</sub>	V <sub>SS</sub>	V <sub>SS</sub>	V <sub>SS</sub>	NC	NC	D7
E	NC	NC	Q11	V <sub>DDQ</sub>	V <sub>SS</sub>	V <sub>SS</sub>	V <sub>SS</sub>	V <sub>DDQ</sub>	NC	D6	Q6
F	NC	Q12	D12	V <sub>DDQ</sub>	V <sub>DD</sub>	V <sub>SS</sub>	V <sub>DD</sub>	V <sub>DDQ</sub>	NC	NC	Q5
G	NC	D13	Q13	V <sub>DDQ</sub>	V <sub>DD</sub>	V <sub>SS</sub>	V <sub>DD</sub>	V <sub>DDQ</sub>	NC	NC	D5
H	/DOFF	V <sub>REF</sub>	V <sub>DDQ</sub>	V <sub>DDQ</sub>	V <sub>DD</sub>	V <sub>SS</sub>	V <sub>DD</sub>	V <sub>DDQ</sub>	V <sub>DDQ</sub>	V <sub>REF</sub>	ZQ
J	NC	NC	D14	V <sub>DDQ</sub>	V <sub>DD</sub>	V <sub>SS</sub>	V <sub>DD</sub>	V <sub>DDQ</sub>	NC	Q4	D4
K	NC	NC	Q14	V <sub>DDQ</sub>	V <sub>DD</sub>	V <sub>SS</sub>	V <sub>DD</sub>	V <sub>DDQ</sub>	NC	D3	Q3
L	NC	Q15	D15	V <sub>DDQ</sub>	V <sub>SS</sub>	V <sub>SS</sub>	V <sub>SS</sub>	V <sub>DDQ</sub>	NC	NC	Q2
M	NC	NC	D16	V <sub>SS</sub>	V <sub>SS</sub>	V <sub>SS</sub>	V <sub>SS</sub>	V <sub>SS</sub>	NC	Q1	D2
N	NC	D17	Q16	V <sub>SS</sub>	SA	SA	SA	V <sub>SS</sub>	NC	NC	D1
P	NC	NC	Q17	SA	SA	C QVLD QVLD	SA	SA	NC	D0	Q0
R	TDO	TCK	SA	SA	SA	/C NC ODT	SA	SA	SA	TMS	TDI

(Top View)

- Notes: 1. Address expansion order for future higher density SRAMs: 10A → 2A → 7A → 5B.  
 2. NC pins can be left floating or connected to 0V ~ V<sub>DDQ</sub>.

**Pin Arrangement**

R1Q3A3609 (Top) / R1QA(G)A3609 (Mid) / R1QD(K)A3609 (Bottom)

	1	2	3	4	5	6	7	8	9	10	11
A	/CQ	NC	SA	/W	NC	/K	NC	/R	SA	SA	CQ
B	NC	NC	NC	SA	NC	K	/BW	SA	NC	NC	Q4
C	NC	NC	NC	V <sub>SS</sub>	SA	NC	SA	V <sub>SS</sub>	NC	NC	D4
D	NC	D5	NC	V <sub>SS</sub>	V <sub>SS</sub>	V <sub>SS</sub>	V <sub>SS</sub>	V <sub>SS</sub>	NC	NC	NC
E	NC	NC	Q5	V <sub>DDQ</sub>	V <sub>SS</sub>	V <sub>SS</sub>	V <sub>SS</sub>	V <sub>DDQ</sub>	NC	D3	Q3
F	NC	NC	NC	V <sub>DDQ</sub>	V <sub>DD</sub>	V <sub>SS</sub>	V <sub>DD</sub>	V <sub>DDQ</sub>	NC	NC	NC
G	NC	D6	Q6	V <sub>DDQ</sub>	V <sub>DD</sub>	V <sub>SS</sub>	V <sub>DD</sub>	V <sub>DDQ</sub>	NC	NC	NC
H	/DOFF	V <sub>REF</sub>	V <sub>DDQ</sub>	V <sub>DDQ</sub>	V <sub>DD</sub>	V <sub>SS</sub>	V <sub>DD</sub>	V <sub>DDQ</sub>	V <sub>DDQ</sub>	V <sub>REF</sub>	ZQ
J	NC	NC	NC	V <sub>DDQ</sub>	V <sub>DD</sub>	V <sub>SS</sub>	V <sub>DD</sub>	V <sub>DDQ</sub>	NC	Q2	D2
K	NC	NC	NC	V <sub>DDQ</sub>	V <sub>DD</sub>	V <sub>SS</sub>	V <sub>DD</sub>	V <sub>DDQ</sub>	NC	NC	NC
L	NC	Q7	D7	V <sub>DDQ</sub>	V <sub>SS</sub>	V <sub>SS</sub>	V <sub>SS</sub>	V <sub>DDQ</sub>	NC	NC	Q1
M	NC	NC	NC	V <sub>SS</sub>	V <sub>SS</sub>	V <sub>SS</sub>	V <sub>SS</sub>	V <sub>SS</sub>	NC	NC	D1
N	NC	D8	NC	V <sub>SS</sub>	SA	SA	SA	V <sub>SS</sub>	NC	NC	NC
P	NC	NC	Q8	SA	SA	C QVLD QVLD	SA	SA	NC	D0	Q0
R	TDO	TCK	SA	SA	SA	/C NC ODT	SA	SA	SA	TMS	TDI

(Top View)

- Notes: 1. Address expansion order for future higher density SRAMs: 10A → 2A → 7A → 5B.  
 2. NC pins can be left floating or connected to 0V ~ V<sub>DDQ</sub>.

## Pin Descriptions

Name	I/O type	Descriptions	Notes
SA	Input	Synchronous address inputs: These inputs are registered and must meet the setup and hold times around the rising edge of K. All transactions operate on a burst-of-four words (two clock periods of bus activity). These inputs are ignored when device is deselected.	
/R	Input	Synchronous read: When low, this input causes the address inputs to be registered and a READ cycle to be initiated. This input must meet setup and hold times around the rising edge of K, and is ignored on the subsequent rising edge of K.	
/W	Input	Synchronous write: When low, this input causes the address inputs to be registered and a WRITE cycle to be initiated. This input must meet setup and hold times around the rising edge of K, and is ignored on the subsequent rising edge of K.	
/BW <sub>x</sub>	Input	Synchronous byte writes: When low, these inputs cause their respective byte to be registered and written during WRITE cycles. These signals are sampled on the same edge as the corresponding data and must meet setup and hold times around the rising edges of K and /K for each of the two rising edges comprising the WRITE cycle. See Byte Write Truth Table for signal to data relationship.	
K, /K	Input	Input clock: This input clock pair registers address and control inputs on the rising edge of K, and registers data on the rising edge of K and the rising edge of /K. /K is ideally 180 degrees out of phase with K. All synchronous inputs must meet setup and hold times around the clock rising edges. These balls cannot remain V <sub>REF</sub> level.	
C, /C <b>(II only)</b>	Input	Output clock: This clock pair provides a user-controlled means of tuning device output data. The rising edge of /C is used as the output timing reference for the first and third output data. The rising edge of C is used as the output timing reference for second and fourth output data. Ideally, /C is 180 degrees out of phase with C. C and /C may be tied high to force the use of K and /K as the output reference clocks instead of having to provide C and /C clocks. If tied high, C and /C must remain high and not to be toggled during device operation. These balls cannot remain V <sub>REF</sub> level.	1
/DOFF	Input	DLL disable: When low, this input causes the DLL to be bypassed for stable, low frequency operation.	
TMS TDI	Input	IEEE1149.1 test inputs: 1.8 V I/O levels. These balls may be left not connected if the JTAG function is not used in the circuit.	
TCK	Input	IEEE1149.1 clock input: 1.8 V I/O levels. This ball must be tied to V <sub>SS</sub> if the JTAG function is not used in the circuit.	
<p>Notes:</p> <p>1. R1Q2, R1Q3, R1Q4, R1Q5, R1Q6 series have C and /C pins. R1QA, R1QB, R1QC, R1QD, R1QE, R1QF, R1QG, R1QH, R1QJ, R1QK, R1QL, R1QM, R1QN, R1QP series do not have C, /C pins. In the series, K and /K are used as the output reference clocks instead of C and /C. Therefore, hereafter, C and /C represent K and /K in this document.</p>			

**R1QAA36\*\*CB\* / R1QDA36\*\*CB\* Series**

Name	I/O type	Descriptions	Notes
ZQ	Input	Output impedance matching input: This input is used to tune the device outputs to the system data bus impedance. Q and CQ output impedance are set to $0.2 \times RQ$ , where RQ is a resistor from this ball to ground. This ball can be connected directly to $V_{DDQ}$ , which enables the minimum impedance mode. This ball cannot be connected directly to $V_{SS}$ or left unconnected. In ODT (On Die Termination) enable devices, the ODT termination values tracks the value of RQ. The ODT range is selected by ODT control input.	
ODT (II+ only)	Input	ODT control: When low; [Option 1] Low range mode is selected. The impedance range is between $52 \Omega$ and $105 \Omega$ (Thevenin equivalent), which follows $0.3 \times RQ$ for $175 \Omega < RQ < 350 \Omega$ . [Option 2] ODT is disabled. When high; High range mode is selected. The impedance range is between $105 \Omega$ and $150 \Omega$ (Thevenin equivalent), which follows $0.6 \times RQ$ for $175 \Omega < RQ < 250 \Omega$ . When floating; [Option 1] High range mode is selected. [Option 2] ODT is disabled.	1
$D_0$ to $D_n$	Input	Synchronous data inputs: Input data must meet setup and hold times around the rising edges of K and /K during WRITE operations. See Pin Arrangement figures for ball site location of individual signals. The $\times 9$ device uses $D_0$ ~ $D_8$ . $D_9$ ~ $D_{35}$ should be treated as NC pin. The $\times 18$ device uses $D_0$ ~ $D_{17}$ . $D_{18}$ ~ $D_{35}$ should be treated as NC pin. The $\times 36$ device uses $D_0$ ~ $D_{35}$ .	
CQ, /CQ	Output	Synchronous echo clock outputs: The edges of these outputs are tightly matched to the synchronous data outputs and can be used as a data valid indication. These signals run freely and do not stop when Q tri-states.	
TDO	Output	IEEE 1149.1 test output: 1.8 V I/O level.	
$Q_0$ to $Q_n$	Output	Synchronous data outputs: Output data is synchronized to the respective C and /C, or to the respective K and /K if C and /C are tied high. This bus operates in response to /R commands. See Pin Arrangement figures for ball site location of individual signals. The $\times 9$ device uses $Q_0$ ~ $Q_8$ . $Q_9$ ~ $Q_{35}$ should be treated as NC pin. The $\times 18$ device uses $Q_0$ ~ $Q_{17}$ . $Q_{18}$ ~ $Q_{35}$ should be treated as NC pin. The $\times 36$ device uses $Q_0$ ~ $Q_{35}$ .	
QVLD (II+ only)	Output	Valid output indicator: The Q Valid indicates valid output data. QVLD is edge aligned with CQ and /CQ.	
$V_{DD}$	Supply	Power supply: 1.8 V nominal. See DC Characteristics and Operating Conditions for range.	2
$V_{DDQ}$	Supply	Power supply: Isolated output buffer supply. Nominally 1.5 V. See DC Characteristics and Operating Conditions for range.	2
$V_{SS}$	Supply	Power supply: Ground.	2
$V_{REF}$	—	HSTL input reference voltage: Nominally $V_{DDQ}/2$ , but may be adjusted to improve system noise margin. Provides a reference voltage for the HSTL input buffers.	
NC	—	No connect: These pins can be left floating or connected to $0V \sim V_{DDQ}$ .	

Notes:

1. Renesas status: Option 1 = Available, Option 2 = Possible.
2. All power supply and ground balls must be connected for proper operation of the device.

Block Diagram (R1QxA3636 / R1QxA3618 / R1QxA3609, x=3,A,D,G,K)

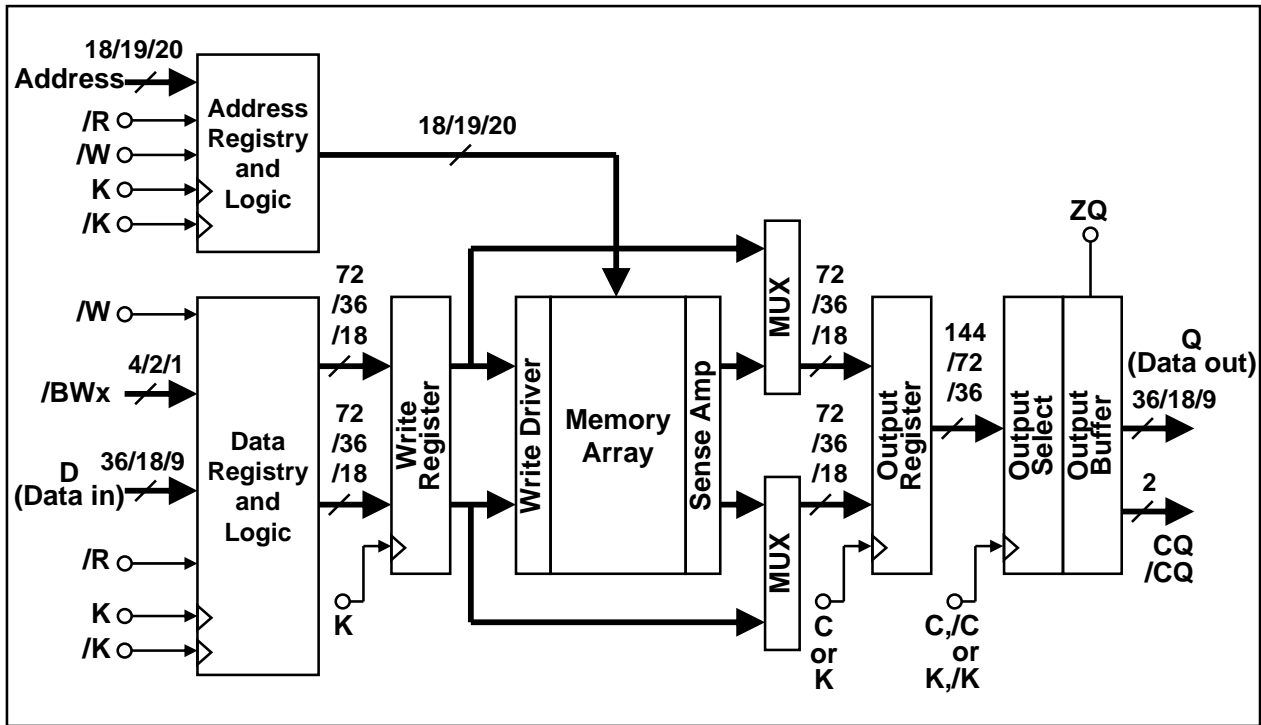

Notes

1. C and /C pins do not exist in II+ series parts.



## General Description

### Power-up and Initialization Sequence

- $V_{DD}$  must be stable before K, /K clocks are applied.
- Recommended voltage application sequence :  $V_{SS} \rightarrow V_{DD} \rightarrow V_{DDQ} \& V_{REF} \rightarrow V_{IN}$ . (0 V to  $V_{DD}$ ,  $V_{DDQ} < 200$  ms)
- Apply  $V_{REF}$  after  $V_{DDQ}$  or at the same time as  $V_{DDQ}$ .
- Then execute either one of the following three sequences.

#### 1. Single Clock Mode (C and /C tied high)

- Drive /DOFF high (/DOFF can be tied high from the start).
- Then provide stable clocks (K, /K) for at least 1024 cycles (II series) or 20 us (II+ series).  
These meet the QDR common specification of 20 us.
- When the operating frequency is less than 180 MHz, 2048 cycles are required (II series).

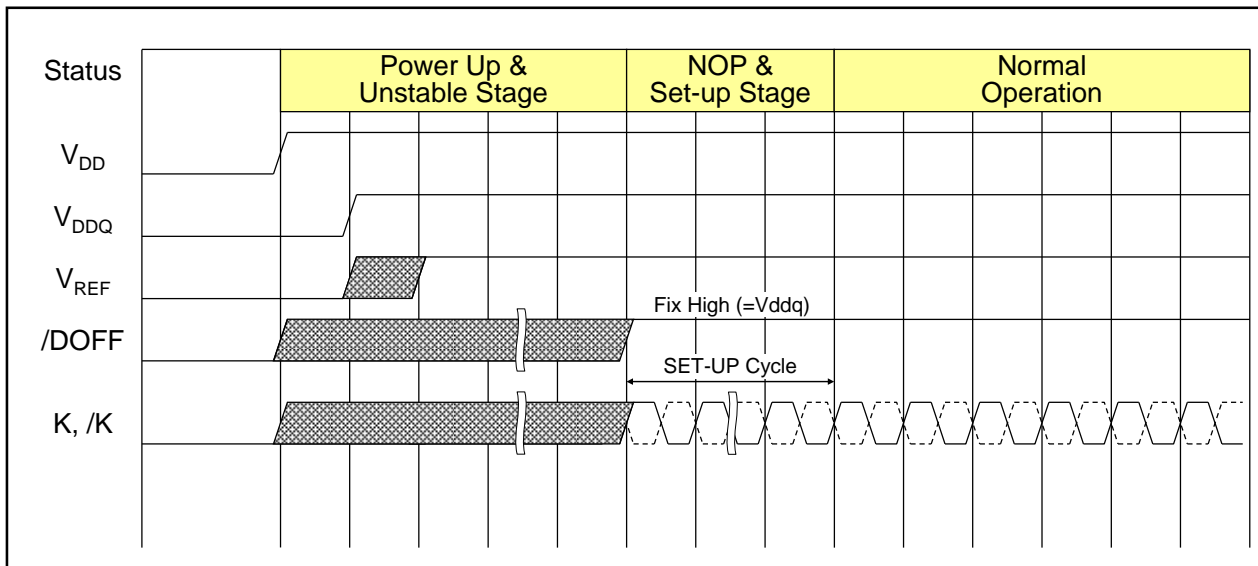

#### 2. Double Clock Mode (C and /C control outputs) (II series only)

- Drive /DOFF high (/DOFF can be tied high from the start)
- Then provide stable clocks (K, /K, C, /C) for at least 1024 cycles (II series).  
This meets the QDR common specification of 20 us.
- When the operating frequency is less than 180 MHz, 2048 cycles are required (II series).

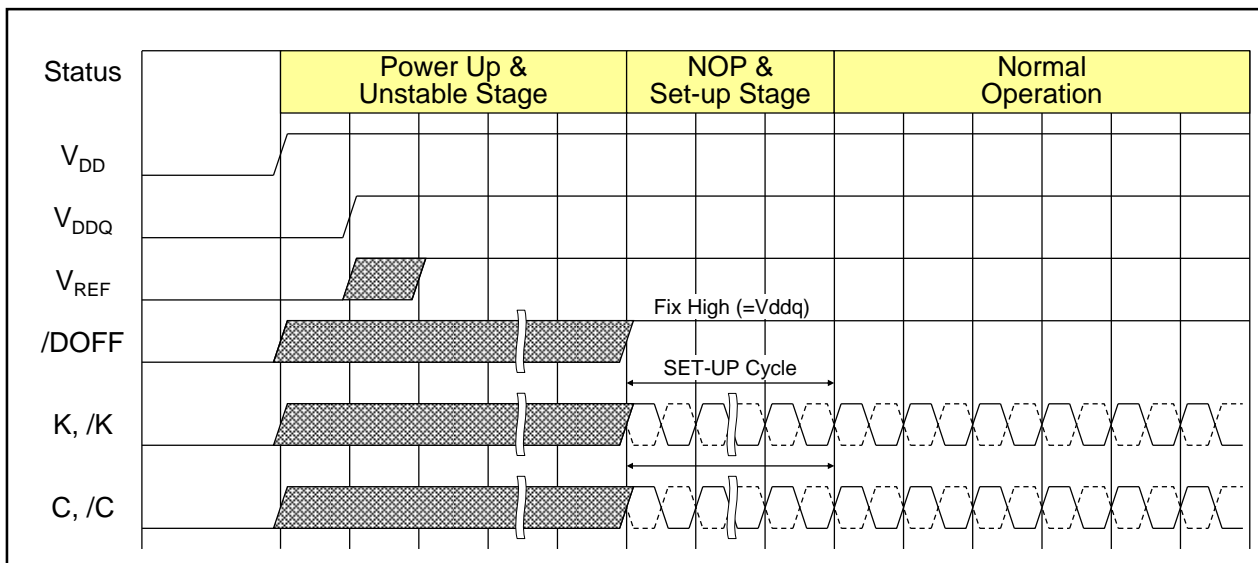

#### 3. DLL Off Mode (/DOFF tied low)

- In the "NOP and setup stage", provide stable clocks (K, /K) for at least 1024 cycles (II series) or 20 us (II+ series). These meet the QDR common specification of 20 us.

**DLL Constraints**

1. DLL uses K clock as its synchronizing input. The input should have low phase jitter which is specified as tKC var.
2. The lower end of the frequency at which the DLL can operate is 120 MHz.  
(Please refer to AC Characteristics table for detail.)
3. When the operating frequency is changed or /DOFF level is changed, setup cycles are required again.

**Programmable Output Impedance**

1. Output buffer impedance can be programmed by terminating the ZQ ball to  $V_{SS}$  through a precision resistor (RQ). The value of RQ is five times the output impedance desired. The allowable range of RQ to guarantee impedance matching with a tolerance of 15% is 250  $\Omega$  typical. The total external capacitance of ZQ ball must be less than 7.5 pF.

**QVLD (Valid data indicator)**

(R1QA, R1QB, R1QC, R1QD, R1QE, R1QF, R1QG, R1QH, R1QJ, R1QK, R1QL, R1QM, R1QN, R1QP series)

1. QVLD is provided on the QDR-II+ and DDR-II+ to simplify data capture on high speed systems. The Q Valid indicates valid output data. QVLD is activated half cycle before the read data for the receiver to be ready for capturing the data. QVLD is inactivated half cycle before the read finish for the receiver to stop capturing the data. QVLD is edge aligned with CQ and /CQ.

**ODT (On Die Termination)**

(R1QD, R1QE, R1QF, R1QK, R1QL, R1QM, R1QP series)

1. To reduce reflection which produces noise and lowers signal quality, the signals should be terminated, especially at high frequency. Renesas offers ODT on the input signals to QDR-II+ and DDR-II+ family of devices. (See the ODT pin table)
2. In ODT enable devices, the ODT termination values tracks the value of RQ. The ODT range is selected by ODT control input. (See the ODT range table)
3. In DDR-II+ devices having common I/O bus, ODT is automatically enabled when the device inputs data and disabled when the device outputs data.
4. There is no difference in AC timing characteristics between the SRAMs with ODT and SRAMs without ODT.
5. There is no increase in the I<sub>DD</sub> of SRAMs with ODT, however, there is an increase in the I<sub>DDQ</sub> (current consumption from the I/O voltage supply) with ODT.

**ODT range**

ODT control pin	Thevenin equivalent resistance (R <sub>THEV</sub> )		Unit	Notes
	Option 1	Option 2		
Low	0.3 × RQ	(ODT disable)	Ω	1, 4
High	0.6 × RQ	0.6 × RQ	Ω	2, 5
Floating	0.6 × RQ	(ODT disable)	Ω	3

Notes:

1. Allowable range of RQ for Option 1 to guarantee impedance matching a tolerance of ± 20 % is 175 Ω < RQ < 350 Ω.
2. Allowable range of RQ to guarantee impedance matching a tolerance of ± 20 % is 175 Ω < RQ < 250 Ω.
3. Allowable range of RQ for Option 1 to guarantee impedance matching a tolerance of ± 20 % is 175 Ω < RQ < 250 Ω.
4. At option 1, ODT control pin is connected to V<sub>DDQ</sub> through 3.5 kΩ. Therefore it is recommended to connect it to V<sub>SS</sub> through less than 100 Ω to make it low.
5. At option 2, ODT control pin is connected to V<sub>SS</sub> through 3.5 kΩ. Therefore it is recommended to connect it to V<sub>DDQ</sub> through less than 100 Ω to make it high.
6. Renesas status: Option 1 = Available, Option 2 = Possible. If you need devices with option 2, please contact Renesas sales office.

Thevenin termination

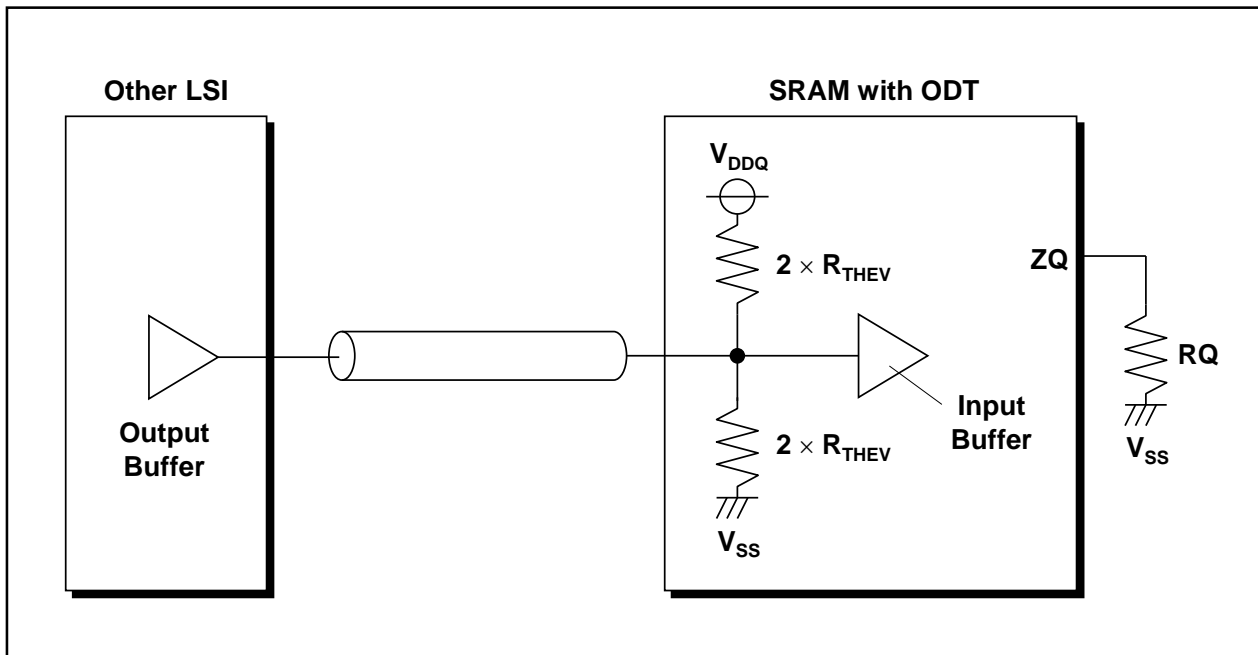

ODT pin (R1QD, R1QE, R1QF, R1QK, R1QL, R1QM, R1QP series)

Pin name	Pin with ODT		ODT On/Off timing	Notes
	Option 1	Option 2	-	3
D <sub>0</sub> ~ D <sub>n</sub> in separate I/O devices			Always On	1
DQ <sub>0</sub> ~ DQ <sub>n</sub> in common I/O devices	Yes	Yes	Off: First Read Command + Read Latency - 0.5 cycle On: Last Read Command + Read Latency + BL/2 cycle + 0.5 cycle (See below timing chart)	2
/BW <sub>x</sub>	Yes	Yes	Always On	
K, /K	Yes	No	Always On (@ Option 1) Always Off (@ Option 2)	

Notes: 1. Separate I/O devices are R1QD, R1QK, R1QP series.  
2. Common I/O devices are R1QE, R1QF, R1QL, R1QM series.  
3. Renesas status: Option 1 = Available, Option 2 = Possible. If you need devices with option 2, please contact Renesas sales office.

ODT on/off Timing Chart for R1QE series (DDR II+, Burst Length=2, Read Latency=2.5 cycle)

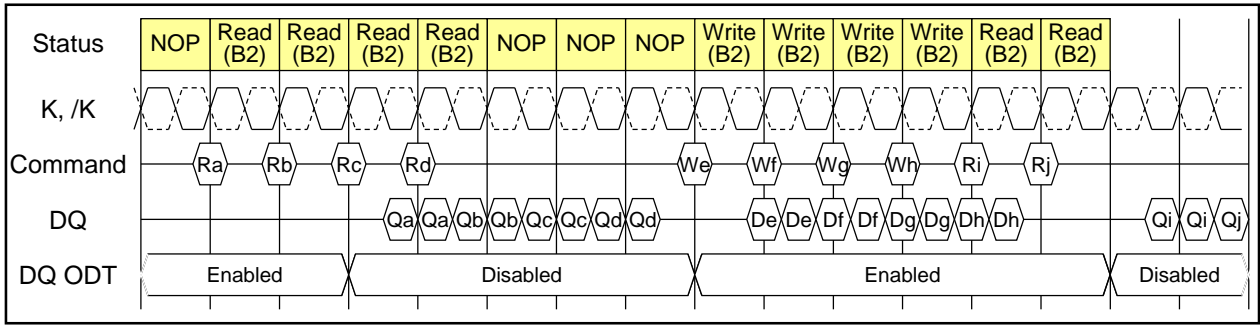

ODT on/off Timing Chart for R1QF series (DDR II+, Burst Length=4, Read Latency=2.5 cycle)

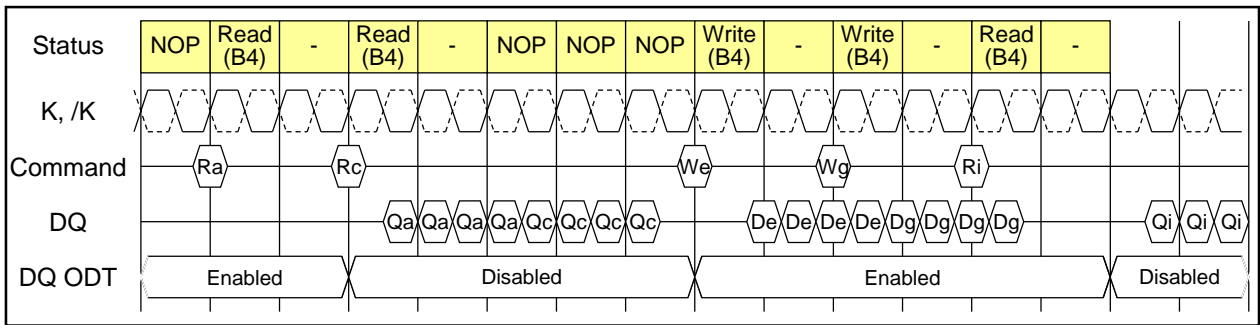

ODT on/off Timing Chart for R1QL series (DDR II+, Burst Length=2, Read Latency=2.0 cycle)

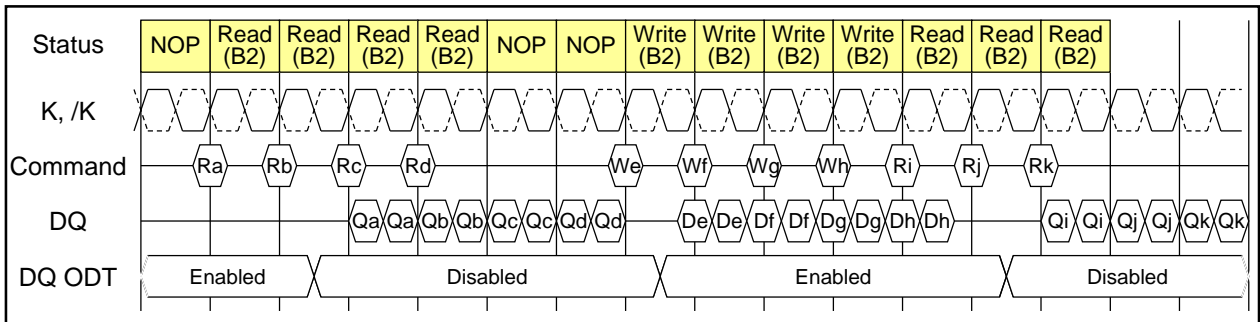

ODT on/off Timing Chart for R1QM series (DDR II+, Burst Length=4, Read Latency=2.0 cycle)

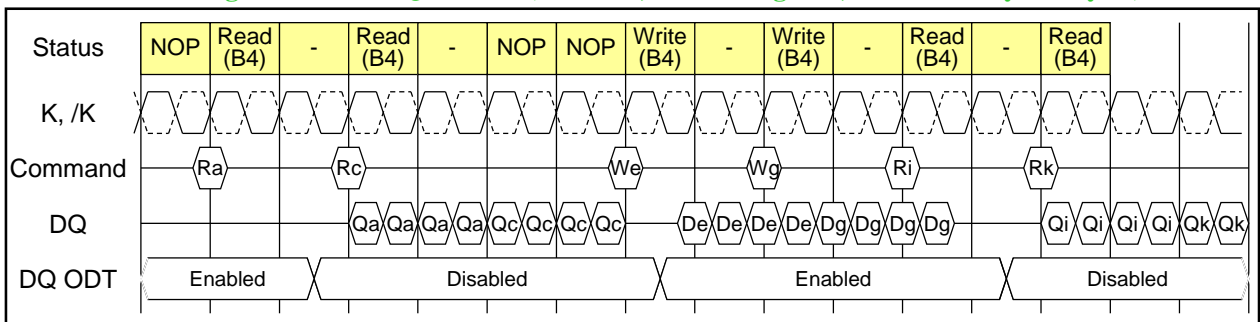

Notes

1. ODT on/off switching timings are edge aligned with CQ or /CQ.

**K Truth Table**

Operation	K	/R	/W	D or Q					
Write Cycle: Load address, input write data on two consecutive K and /K rising edges	↑	H*7	L*8	Data in					
				Input data	D(A+0)	D(A+1)	D(A+2)	D(A+3)	
				Input clock	K(t+1) ↑	/K(t+1) ↑	K(t+2) ↑	/K(t+2) ↑	
Read Cycle: Load address, output read data on two consecutive C and /C rising edges	↑	L*8	×	Data out					
				Output data	Q(A+0)	Q(A+1)	Q(A+2)	Q(A+3)	
				Input clock for Q	RL*9=1.5	/C(t+1) ↑	C(t+2) ↑	/C(t+2) ↑	C(t+3) ↑
					RL=2.0	C(t+2) ↑	/C(t+2) ↑	C(t+3) ↑	/C(t+3) ↑
RL=2.5	/C(t+2) ↑	C(t+3) ↑	/C(t+3) ↑		C(t+4) ↑				
NOP (No operation)	↑	H	H	D = × or Q = High-Z					
Standby (Clock stopped)	Stopped	×	×	Previous state					

Notes:

1. H: high level, L: low level, ×: don't care, ↑: rising edge.
2. Data inputs are registered at K and /K rising edges. Data outputs are delivered at C and /C rising edges, except if C and /C are high, then data outputs are delivered at K and /K rising edges.
3. /R and /W must meet setup/hold times around the rising edges (low to high) of K and are registered at the rising edge of K.
4. This device contains circuitry that will ensure the outputs will be in high-Z during power-up.
5. Refer to state diagram and timing diagrams for clarification.
6. When clocks are stopped, the following cases are recommended; the case of K = low, /K = high, C = low and /C = high, or the case of K = high, /K = low, C = high and /C = low. This condition is not essential, but permits most rapid restart by overcoming transmission line charging symmetrically.
7. If this signal was low to initiate the previous cycle, this signal becomes a "don't care" for this operation; however, it is strongly recommended that this signal be brought high, as shown in the truth table.
8. This signal was high on previous K clock rising edge. Initiating consecutive READ or WRITE operations on consecutive K clock rising edges is not permitted. The device will ignore the second request.
9. RL = Read Latency (unit = cycle).

Byte Write Truth Table ( x 36 )

Operation	K	/K	/BW0	/BW1	/BW2	/BW3
Write D0 to D35	↑	-	L	L	L	L
	-	↑	L	L	L	L
Write D0 to D8	↑	-	L	H	H	H
	-	↑	L	H	H	H
Write D9 to D17	↑	-	H	L	H	H
	-	↑	H	L	H	H
Write D18 to D26	↑	-	H	H	L	H
	-	↑	H	H	L	H
Write D27 to D35	↑	-	H	H	H	L
	-	↑	H	H	H	L
Write nothing	↑	-	H	H	H	H
	-	↑	H	H	H	H

Notes:  
 1. H: high level, L: low level, ↑: rising edge.  
 2. Assumes a WRITE cycle was initiated. /BWx can be altered for any portion of the BURST WRITE operation provided that the setup and hold requirements are satisfied.

Byte Write Truth Table ( x 18 )

Operation	K	/K	/BW0	/BW1
Write D0 to D17	↑	-	L	L
	-	↑	L	L
Write D0 to D8	↑	-	L	H
	-	↑	L	H
Write D9 to D17	↑	-	H	L
	-	↑	H	L
Write nothing	↑	-	H	H
	-	↑	H	H

Notes:  
 1. H: high level, L: low level, ↑: rising edge.  
 2. Assumes a WRITE cycle was initiated. /BWx can be altered for any portion of the BURST WRITE operation provided that the setup and hold requirements are satisfied.

Byte Write Truth Table ( x 9 )

Operation	K	/K	/BW
Write D0 to D8	↑	-	L
	-	↑	L
Write nothing	↑	-	H
	-	↑	H

Notes:  
 1. H: high level, L: low level, ↑: rising edge.  
 2. Assumes a WRITE cycle was initiated. /BWx can be altered for any portion of the BURST WRITE operation provided that the setup and hold requirements are satisfied.

### Bus Cycle State Diagram

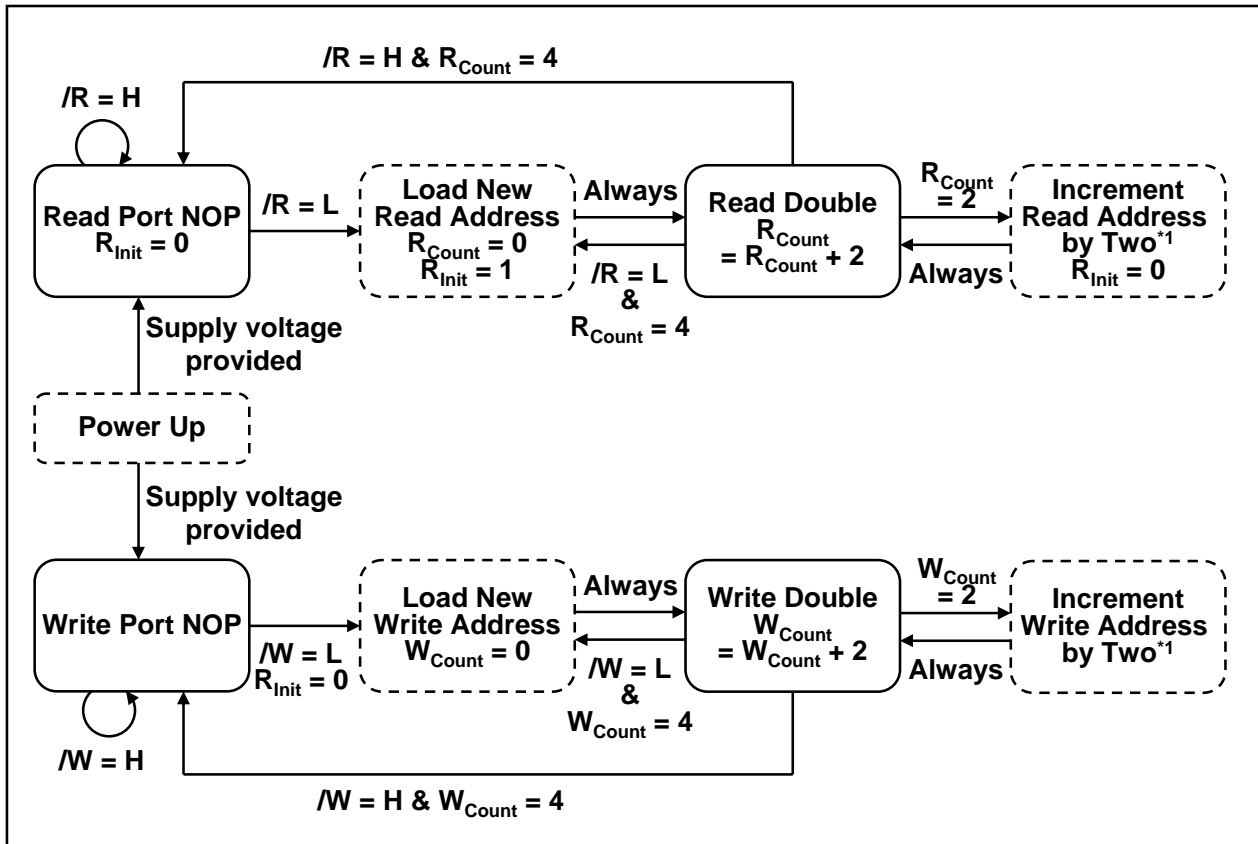

Notes:

1. The address is concatenated with two additional internal LSBs to facilitate burst operation. The address order is always fixed as: xxx...xxx+0, xxx...xxx+1, xxx...xxx+2, xxx...xxx+3. Bus cycle is terminated at the end of this sequence (burst count = 4).
2. Read and write state machines can be active simultaneously. Read and write cannot be simultaneously initiated. Read takes precedence.
3. State machine control timing sequence is controlled by K.



## Absolute Maximum Ratings

Parameter	Symbol	Rating	Unit	Notes
Input voltage on any ball	$V_{IN}$	-0.5 to $V_{DD} + 0.5$ (2.5 V max.)	V	1, 4
Input/output voltage	$V_{I/O}$	-0.5 to $V_{DDQ} + 0.5$ (2.5 V max.)	V	1, 4
Core supply voltage	$V_{DD}$	-0.5 to 2.5	V	1, 4
Output supply voltage	$V_{DDQ}$	-0.5 to $V_{DD}$	V	1, 4
Junction temperature	$T_j$	+125 (max)	°C	5
Storage temperature	$T_{STG}$	-55 to +125	°C	

### Notes:

- All voltage is referenced to  $V_{SS}$ .
- Permanent device damage may occur if Absolute Maximum Ratings are exceeded. Functional operation should be restricted the Operation Conditions. Exposure to higher than recommended voltages for extended periods of time could affect device reliability.
- These CMOS memory circuits have been designed to meet the DC and AC specifications shown in the tables after thermal equilibrium has been established.
- The following supply voltage application sequence is recommended:  $V_{SS}$ ,  $V_{DD}$ ,  $V_{DDQ}$ ,  $V_{REF}$  then  $V_{IN}$ . Remember, according to the Absolute Maximum Ratings table,  $V_{DDQ}$  is not to exceed 2.5 V, whatever the instantaneous value of  $V_{DDQ}$ .
- Some method of cooling or airflow should be considered in the system. (Especially for high frequency or ODT parts)

## Recommended DC Operating Conditions

Parameter	Symbol	Min	Typ	Max	Unit	Notes
Power supply voltage -- core	$V_{DD}$	1.7	1.8	1.9	V	1
Power supply voltage -- I/O	$V_{DDQ}$	1.4	1.5	$V_{DD}$	V	1, 2
Input reference voltage -- I/O	$V_{REF}$	0.68	0.75	0.95	V	3
Input high voltage	$V_{IH(DC)}$	$V_{REF} + 0.1$	—	$V_{DDQ} + 0.3$	V	1, 4, 5
Input low voltage	$V_{IL(DC)}$	-0.3	—	$V_{REF} - 0.1$	V	1, 4, 5

### Notes:

- At power-up,  $V_{DD}$  and  $V_{DDQ}$  are assumed to be a linear ramp from 0V to  $V_{DD}$  (min.) or  $V_{DDQ}$  (min.) within 200ms. During this time  $V_{DDQ} < V_{DD}$  and  $V_{IH} < V_{DDQ}$ . During normal operation,  $V_{DDQ}$  must not exceed  $V_{DD}$ .
- Please pay attention to  $T_j$  not to exceed the temperature shown in the absolute maximum ratings table due to current from  $V_{DDQ}$ .
- Peak to peak AC component superimposed on  $V_{REF}$  may not exceed 5% of  $V_{REF}$ .
- These are DC test criteria. The AC  $V_{IH} / V_{IL}$  levels are defined separately to measure timing parameters.
- Overshoot:  $V_{IH(AC)} \leq V_{DDQ} + 0.5$  V for  $t \leq t_{KHKH}/2$   
Undershoot:  $V_{IL(AC)} \geq -0.5$  V for  $t \leq t_{KHKH}/2$   
During normal operation,  $V_{IH(DC)}$  must not exceed  $V_{DDQ}$  and  $V_{IL(DC)}$  must not be lower than  $V_{SS}$ .

## R1QAA36\*\*CB\* / R1QDA36\*\*CB\* Series

### DC Characteristics

(Ta = 0 ~ +70°C @ R1Q\*A\*\*\*\*\*BG-\*\*R\*\* series, Ta = -40 ~ +85°C @ R1Q\*A\*\*\*\*\*BG-\*\*I\*\* series)  
(V<sub>DD</sub> = 1.8V ±0.1V, V<sub>DDQ</sub> = 1.5V, V<sub>REF</sub> = 0.75V)

### Operating Supply Current (Write / Read)

Symbol = I<sub>DD</sub>. Unit = mA. See Notes 1, 2 and 3 in the page after next.

No	Product Type	Burst Length	Latency (Cycle)	ODT	Organi- zation	QDR II+ / DDR II+						QDR II / DDR II			
						Frequency (max) (MHz)						333	300	250	200
						Cycle Time (min) (ns)						1.875	2.00	2.22	2.50
Part Number ↓		yy →		-19	-20	-22	-25	-27	-30	-30	-33	-40	-50		
17	QDRII+	B4	2.5	No	x18	R1Q A A36 18 CBv-yy	1220	1160	1070						
18					x36	R1Q A A36 36 CBv-yy	1280	1220	1130						
20	DDRII+	B2	2.5	No	x18	R1Q B A36 18 CBv-yy	1030	990	920						
21		x36			R1Q B A36 36 CBv-yy	1110	1060	990							
23	DDRII+	B4	2.5	No	x18	R1Q C A36 18 CBv-yy	820	790	750						
24					x36	R1Q C A36 36 CBv-yy	880	850	800						
26	QDRII+	B4	2.5	Yes	x18	R1Q D A36 18 CBv-yy	1220	1160	1070						
27					x36	R1Q D A36 36 CBv-yy	1280	1220	1130						
29	DDRII+	B2	2.5	Yes	x18	R1Q E A36 18 CBv-yy	1030	990	920						
30		x36			R1Q E A36 36 CBv-yy	1110	1060	990							
32	DDRII+	B4	2.5	Yes	x18	R1Q F A36 18 CBv-yy	820	790	750						
33					x36	R1Q F A36 36 CBv-yy	880	850	800						
35	QDRII+	B4	2.0	No	x18	R1Q G A36 18 CBv-yy				980					
36					x36	R1Q G A36 36 CBv-yy				1060					
38	DDRII+	B2	2.0	No	x18	R1Q H A36 18 CBv-yy				850					
39		x36			R1Q H A36 36 CBv-yy				910						
41	DDRII+	B4	2.0	No	x18	R1Q J A36 18 CBv-yy				710					
42					x36	R1Q J A36 36 CBv-yy				760					
44	QDRII+	B4	2.0	Yes	x18	R1Q K A36 18 CBv-yy				980					
45					x36	R1Q K A36 36 CBv-yy				1060					
47	DDRII+	B2	2.0	Yes	x18	R1Q L A36 18 CBv-yy				850					
48		x36			R1Q L A36 36 CBv-yy				910						
50	DDRII+	B4	2.0	Yes	x18	R1Q M A36 18 CBv-yy				710					
51					x36	R1Q M A36 36 CBv-yy				760					

Notes:

- "yy" represents the speed bin. "R1QAA3636CBG-20" can operate at 500 MHz(max) of frequency, for example.
- "v" represents the package size. If "v" = "G" then size is 15 x 17 mm, and if "v" = "A" then 13 x 15 mm.

**R1QAA36\*\*CB\* / R1QDA36\*\*CB\* Series**

**Standby Supply Current (NOP)**

Symbol =  $I_{SB1}$ . Unit = mA. See Notes 2, 4 and 5 in the next page.

No	Product Type	Burst Length	Latency (Cycle)	ODT	Organi- zation	Frequency (max) (MHz)	QDR II+ / DDR II+						QDR II / DDR II				
							Cycle Time (min) (ns)	533	500	450	400	375	333	333	300	250	200
								1.875	2.00	2.22	2.50	2.66	3.00	3.00	3.30	4.00	5.00
Part Number ↓						yy →	-19	-20	-22	-25	-27	-30	-30	-33	-40	-50	
17	QDRII+	B4	2.5	No	x18	R1Q A A36 18 CBv-yy	870	830	780								
18					x36	R1Q A A36 36 CBv-yy	910	870	810								
20	DDRII+	B2			x18	R1Q B A36 18 CBv-yy	870	840	780								
21					x36	R1Q B A36 36 CBv-yy	960	920	860								
23	B4	x18			R1Q C A36 18 CBv-yy	690	660	630									
24		x36			R1Q C A36 36 CBv-yy	730	710	670									
26	QDRII+	B4	2.5	Yes	x18	R1Q D A36 18 CBv-yy	870	830	780								
27					x36	R1Q D A36 36 CBv-yy	910	870	810								
29	DDRII+	B2			x18	R1Q E A36 18 CBv-yy	870	840	780								
30					x36	R1Q E A36 36 CBv-yy	960	920	860								
32	B4	x18			R1Q F A36 18 CBv-yy	690	660	630									
33		x36			R1Q F A36 36 CBv-yy	730	710	670									
35	QDRII+	B4	2.0	No	x18	R1Q G A36 18 CBv-yy				720							
36					x36	R1Q G A36 36 CBv-yy				770							
38	DDRII+	B2			x18	R1Q H A36 18 CBv-yy				720							
39					x36	R1Q H A36 36 CBv-yy				790							
41	B4	x18			R1Q J A36 18 CBv-yy				590								
42		x36			R1Q J A36 36 CBv-yy				630								
44	QDRII+	B4	2.0	Yes	x18	R1Q K A36 18 CBv-yy				720							
45					x36	R1Q K A36 36 CBv-yy				770							
47	DDRII+	B2			x18	R1Q L A36 18 CBv-yy				720							
48					x36	R1Q L A36 36 CBv-yy				790							
50	B4	x18			R1Q M A36 18 CBv-yy				590								
51		x36			R1Q M A36 36 CBv-yy				630								

Notes:

- "yy" represents the speed bin. "R1QAA3636CBG-20" can operate at 500 MHz(max) of frequency, for example.
- "v" represents the package size. If "v" = "G" then size is 15 x 17 mm, and if "v" = "A" then 13 x 15 mm.

Leakage Currents & Output Voltage

Parameter	Symbol	Min	Max	Unit	Test condition	Notes
Input leakage current	$I_{LI}$	-2	2	$\mu\text{A}$		10
Output leakage current	$I_{LO}$	-5	5	$\mu\text{A}$		11
Output high voltage	$V_{OH}$ (LOW)	$V_{DDQ} - 0.2$	$V_{DDQ}$	V	$ I_{OH}  \leq 0.1 \text{ mA}$	8, 9
	$V_{OH}$	$V_{DDQ}/2 - 0.12$	$V_{DDQ}/2 + 0.12$	V	Note 6	8, 9
Output low voltage	$V_{OL}$ (LOW)	$V_{SS}$	0.2	V	$I_{OL} \leq 0.1 \text{ mA}$	8, 9
	$V_{OL}$	$V_{DDQ}/2 - 0.12$	$V_{DDQ}/2 + 0.12$	V	Note 7	8, 9

Notes:

- All inputs (except ZQ,  $V_{REF}$ ) are held at either  $V_{IH}$  or  $V_{IL}$ .
- $I_{OUT} = 0 \text{ mA}$ .  $V_{DD} = V_{DD} \text{ max}$ ,  $t_{KHKH} = t_{KHKH} \text{ min}$ .
- Operating supply currents ( $I_{DD}$ ) are measured at 100% bus utilization.  $I_{DD}$  of QDR family is current of device with 100% write and 100% read cycle.  $I_{DD}$  of DDR family is current of device with 100% write cycle (if  $I_{DD}(\text{Write}) > I_{DD}(\text{Read})$ ) or 100% read cycle (if  $I_{DD}(\text{Write}) < I_{DD}(\text{Read})$ ).
- All address / data inputs are static at either  $V_{IN} > V_{IH}$  or  $V_{IN} < V_{IL}$ .
- Reference value. (Condition = NOP currents are valid when entering NOP after all pending READ and WRITE cycles are completed.)
- Outputs are impedance-controlled.  $|I_{OH}| = (V_{DDQ}/2)/(RQ/5)$  for values of  $175 \Omega \leq RQ \leq 350 \Omega$ .
- Outputs are impedance-controlled.  $I_{OL} = (V_{DDQ}/2)/(RQ/5)$  for values of  $175 \Omega \leq RQ \leq 350 \Omega$ .
- AC load current is higher than the shown DC values. AC I/O curves are available upon request.
- HSTL outputs meet JEDEC HSTL Class I and Class II standards.
- $0 \leq V_{IN} \leq V_{DDQ}$  for all input balls (except  $V_{REF}$ , ZQ, TCK, TMS, TDI ball).  
If R1QD, R1QE, R1QF, R1QK, R1QL, R1QM, R1QP series, balls with ODT do not follow this spec.
- $0 \leq V_{OUT} \leq V_{DDQ}$  (except TDO ball), output disabled.

### Thermal Resistance

Parameter	Symbol	Airflow	Typ	Unit	Test condition	Notes
Junction to Ambient	$\theta_{JA}$	1 m/s	11.0	°C/W	EIA/JEDEC JESD51	1
Junction to Case	$\theta_{JC}$	-	4.4			

Notes:

- These parameters are calculated under the condition. These are reference values.
- $T_j = T_a + \theta_{JA} \times P_d$   
 $T_j = T_c + \theta_{JC} \times P_d$   
 where  
 $T_j$ : junction temperature when the device has achieved a steady-state after application of  $P_d$  (°C)  
 $T_a$ : ambient temperature (°C)  
 $T_c$ : temperature of external surface of the package or case (°C)  
 $\theta_{JA}$ : thermal resistance from junction-to-ambient (°C/W)  
 $\theta_{JC}$ : thermal resistance from junction-to-case (package) (°C/W)  
 $P_d$ : power dissipation that produced change in junction temperature (W) (cf.JESD51-2A)

### Capacitance

( $T_a = +25^\circ\text{C}$ , Frequency = 1.0MHz,  $V_{DD} = 1.8\text{V}$ ,  $V_{DDQ} = 1.5\text{V}$ )

Parameter	Symbol	Min	Typ	Max	Unit	Test condition	Notes
Input capacitance (SA, /R, /W, /BW, D(separate))	$C_{IN}$	—	4	5	pF	$V_{IN} = 0\text{V}$	1, 2
Clock input capacitance (K, /K, C, /C)	$C_{CLK}$	—	4	5	pF	$V_{CLK} = 0\text{V}$	1, 2
Output capacitance (Q(separate), DQ(common), CQ, /CQ)	$C_{I/O}$	—	5	6	pF	$V_{I/O} = 0\text{V}$	1, 2

Notes:

- These parameters are sampled and not 100% tested.
- Except JTAG (TCK, TMS, TDI, TDO) pins.

### AC Test Conditions

Input waveform (Rise/fall time  $\leq 0.3\text{ ns}$ )

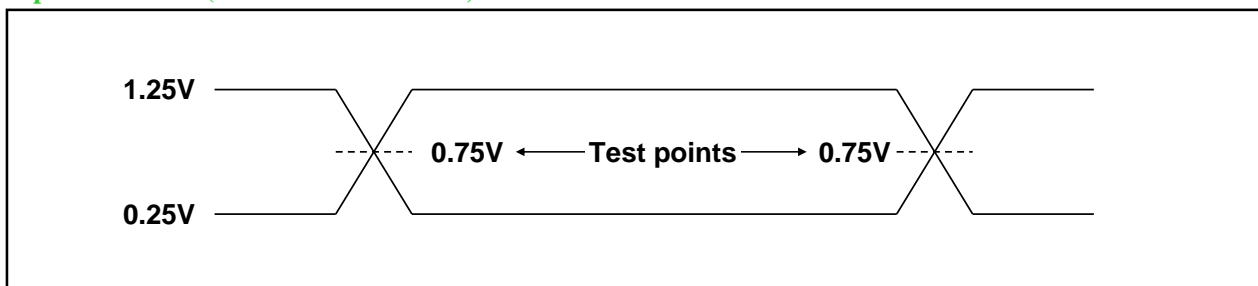

Output waveform

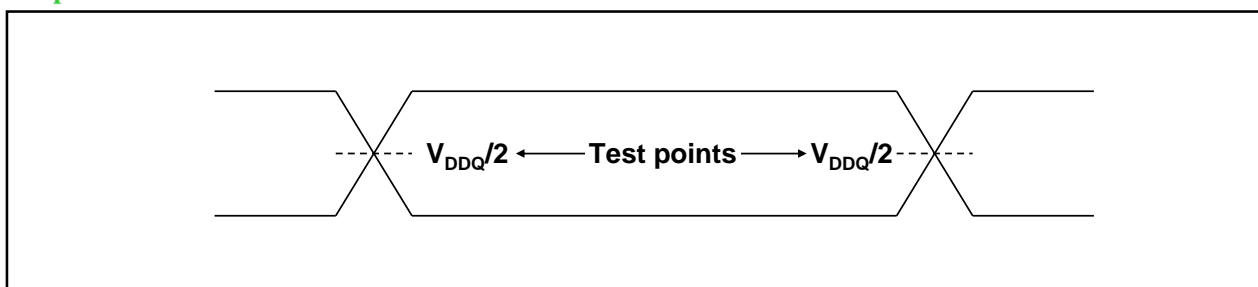

Output load conditions

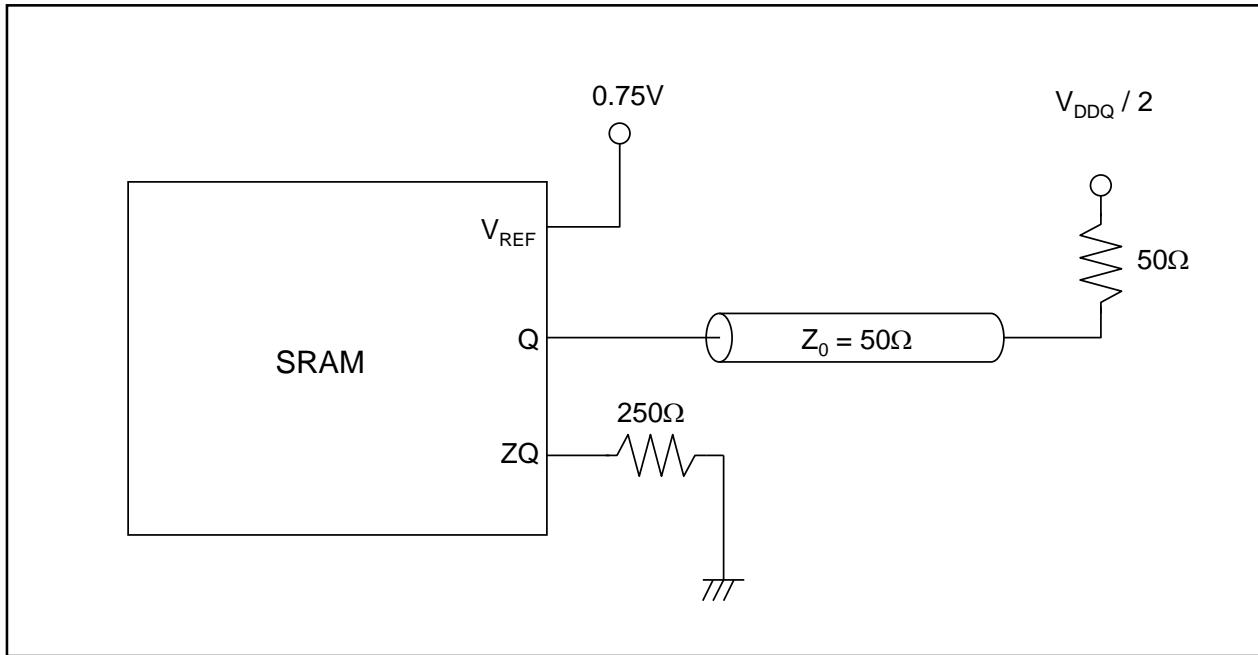

AC Operating Conditions

Parameter	Symbol	Min	Typ	Max	Unit	Notes
Input high voltage	$V_{IH(AC)}$	$V_{REF} + 0.2$	—	—	V	1, 2, 3, 4
Input low voltage	$V_{IL(AC)}$	—	—	$V_{REF} - 0.2$	V	1, 2, 3, 4

Notes:

1. All voltages referenced to  $V_{SS}$  (GND).  
During normal operation,  $V_{DDQ}$  must not exceed  $V_{DD}$ .
2. These conditions are for AC functions only, not for AC parameter test.
3. Overshoot:  $V_{IH(AC)} \leq V_{DDQ} + 0.5 \text{ V}$  for  $t \leq t_{KHKH}/2$   
Undershoot:  $V_{IL(AC)} \geq -0.5 \text{ V}$  for  $t \leq t_{KHKH}/2$   
Control input signals may not have pulse widths less than  $t_{KHKL}$  (min) or operate at cycle rates less than  $t_{KHKH}$  (min).
4. To maintain a valid level, the transitioning edge of the input must:
  - a. Sustain a constant slew rate from the current AC level through the target AC level,  $V_{IL(AC)}$  or  $V_{IH(AC)}$ .
  - b. Reach at least the target AC level.
  - c. After the AC target level is reached, continue to maintain at least the target DC level,  $V_{IL(DC)}$  or  $V_{IH(DC)}$ .

**AC Characteristics (Read Latency = 2.5 cycle)**

(Ta = 0 ~ +70°C @ R1Q\*A\*\*\*\*\*BG-\*\*R\*\* series)

(Ta = -40 ~ +85°C @ R1Q\*A\*\*\*\*\*BG-\*\*I\*\* series)

(V<sub>DD</sub> = 1.8V ±0.1V, V<sub>DDQ</sub> = 1.5V, V<sub>REF</sub> = 0.75V)

Parameter	Symbol	-19		-20		-22		-25		-27		-30		Unit	Notes
		Min	Max	Min	Max	Min	Max	Min	Max	Min	Max	Min	Max		
Clock															
Average clock cycle time (K, /K)	t <sub>KHKH</sub>	1.875	4.00	2.00	4.00	2.22	4.00	2.50	4.00	2.66	4.00	3.00	4.00	ns	
Clock high time (K, /K)	t <sub>KHKL</sub>	0.40	—	0.40	—	0.40	—	0.40	—	0.40	—	0.40	—	Cycle	
Clock low time (K, /K)	t <sub>KLKH</sub>	0.40	—	0.40	—	0.40	—	0.40	—	0.40	—	0.40	—	Cycle	
Clock to /clock (K to /K)	t <sub>KH/KH</sub>	0.425	—	0.425	—	0.425	—	0.425	—	0.425	—	0.425	—	Cycle	
/Clock to clock (/K to K)	t <sub>/KH/KH</sub>	0.425	—	0.425	—	0.425	—	0.425	—	0.425	—	0.425	—	Cycle	
—	—	—	—	—	—	—	—	—	—	—	—	—	—	—	—
DLL Timing															
Clock phase jitter (K, /K)	t <sub>KC var</sub>	—	0.15	—	0.15	—	0.15	—	0.20	—	0.20	—	0.20	ns	3
DLL lock time (K)	t <sub>KC lock</sub>	20	—	20	—	20	—	20	—	20	—	20	—	us	2
K static to DLL reset	t <sub>KC reset</sub>	30	—	30	—	30	—	30	—	30	—	30	—	ns	7
Output Times															
K, /K high to output valid	t <sub>CHQV</sub>	—	0.45	—	0.45	—	0.45	—	0.45	—	0.45	—	0.45	ns	
K, /K high to output hold	t <sub>CHQX</sub>	-0.45	—	-0.45	—	-0.45	—	-0.45	—	-0.45	—	-0.45	—	ns	
K, /K high to echo clock valid	t <sub>CHCQV</sub>	—	0.45	—	0.45	—	0.45	—	0.45	—	0.45	—	0.45	ns	
K, /K high to echo clock hold	t <sub>CHCQX</sub>	-0.45	—	-0.45	—	-0.45	—	-0.45	—	-0.45	—	-0.45	—	ns	
CQ, /CQ high to output valid	t <sub>CQHQV</sub>	—	0.15	—	0.15	—	0.15	—	0.20	—	0.20	—	0.20	ns	4, 7
CQ, /CQ high to output hold	t <sub>CQHQX</sub>	-0.15	—	-0.15	—	-0.15	—	-0.20	—	-0.20	—	-0.20	—	ns	4, 7
K, /K high to output high-Z	t <sub>CHQZ</sub>	—	0.45	—	0.45	—	0.45	—	0.45	—	0.45	—	0.45	ns	5, 6
K, /K high to output low-Z	t <sub>CHQX1</sub>	-0.45	—	-0.45	—	-0.45	—	-0.45	—	-0.45	—	-0.45	—	ns	5
CQ high to QVLD valid	t <sub>QVLD</sub>	-0.15	0.15	-0.15	0.15	-0.15	0.15	-0.20	0.20	-0.20	0.20	-0.20	0.20	ns	7

**R1QAA36\*\*CB\* / R1QDA36\*\*CB\* Series**

Parameter	Symbol	-19		-20		-22		-25		-27		-30		Unit	Notes
		Min	Max	Min	Max	Min	Max	Min	Max	Min	Max	Min	Max		
Setup Times															
Address valid to K rising edge	$t_{AVKH}$ for QDR	0.30	—	0.33	—	0.40	—	0.40	—	0.40	—	0.40	—	ns	1, 8
	$t_{AVKH}$ for DDR	0.30	—	0.33	—	0.40	—	0.40	—	0.40	—	0.40	—		
Control inputs valid to K rising edge	$t_{IVKH}$ for QDR	0.30	—	0.33	—	0.40	—	0.40	—	0.40	—	0.40	—	ns	1, 8
	$t_{IVKH}$ for DDR	0.30	—	0.33	—	0.40	—	0.40	—	0.40	—	0.40	—		
Data-in valid to K, /K rising edge	$t_{DVKH}$	0.20	—	0.22	—	0.25	—	0.28	—	0.28	—	0.28	—	ns	1, 9
Hold Times															
K rising edge to address hold	$t_{KHAX}$ for QDR	0.30	—	0.33	—	0.40	—	0.40	—	0.40	—	0.40	—	ns	1, 8
	$t_{KHAX}$ for DDR	0.30	—	0.33	—	0.40	—	0.40	—	0.40	—	0.40	—		
K rising edge to control inputs hold	$t_{KHIX}$ for QDR	0.30	—	0.33	—	0.40	—	0.40	—	0.40	—	0.40	—	ns	1, 8
	$t_{KHIX}$ for DDR	0.30	—	0.33	—	0.40	—	0.40	—	0.40	—	0.40	—		
K, /K rising edge to data-in hold	$t_{KHDX}$	0.20	—	0.22	—	0.25	—	0.28	—	0.28	—	0.28	—	ns	1, 9

Notes:

1. This is a synchronous device. All addresses, data and control lines must meet the specified setup and hold times for all latching clock edges.
2.  $V_{DD}$  slew rate must be less than 0.1 V DC per 50 ns for DLL lock retention. DLL lock time begins once  $V_{DD}$  and input clock are stable. It is recommended that the device is kept inactive during these cycles. This specification meets the QDR common spec. of 20 us.
3. Clock phase jitter is the variance from clock rising edge to the next expected clock rising edge.
4. Echo clock is very tightly controlled to data valid / data hold. By design, there is a  $\pm 0.1$  ns variation from echo clock to data. The datasheet parameters reflect tester guardbands and test setup variations.
5. Transitions are measured  $\pm 100$  mV from steady-state voltage.
6. At any given voltage and temperature  $t_{CHQZ}$  is less than  $t_{CHQX1}$  and  $t_{CHQV}$ .
7. These parameters are sampled.
8.  $t_{AVKH}$ ,  $t_{IVKH}$ ,  $t_{KHAX}$ ,  $t_{KHIX}$  spec is determined by the actual frequency regardless of Part Number (Marking Name). The following is the spec for the actual frequency.  
 0.30 ns for  $\leq 533\text{MHz}$  &  $> 500\text{MHz}$   
 0.33 ns for  $\leq 500\text{MHz}$  &  $> 450\text{MHz}$   
 0.40 ns for  $\leq 450\text{MHz}$  &  $\geq 250\text{MHz}$
9.  $t_{DVKH}$ ,  $t_{KHDX}$  spec is determined by the actual frequency regardless of Part Number (Marking Name). The following is the spec for the actual frequency.  
 0.20 ns for  $\leq 533\text{MHz}$  &  $> 500\text{MHz}$   
 0.22 ns for  $\leq 500\text{MHz}$  &  $> 450\text{MHz}$   
 0.25 ns for  $\leq 450\text{MHz}$  &  $> 400\text{MHz}$   
 0.28 ns for  $\leq 400\text{MHz}$  &  $> 300\text{MHz}$   
 0.30 ns for  $\leq 300\text{MHz}$  &  $\geq 250\text{MHz}$

Remarks:

1. Test conditions as specified with the output loading as shown in AC Test Conditions unless otherwise noted.
2. Control input signals may not be operated with pulse widths less than  $t_{KHKL}$  (min).
3.  $V_{DDQ}$  is +1.5 V DC.  $V_{REF}$  is +0.75 V DC.
4. Control signals are /R, /W (QDR series), /LD, R-/W (DDR series), /BW, /BW0, /BW1, /BW2 and /BW3. Setup and hold times of /BWx signals must be the same as those of Data-in signals.



Timing Waveforms

Read and Write Timing (QDRII+, B4, Read Latency = 2.5 cycle)

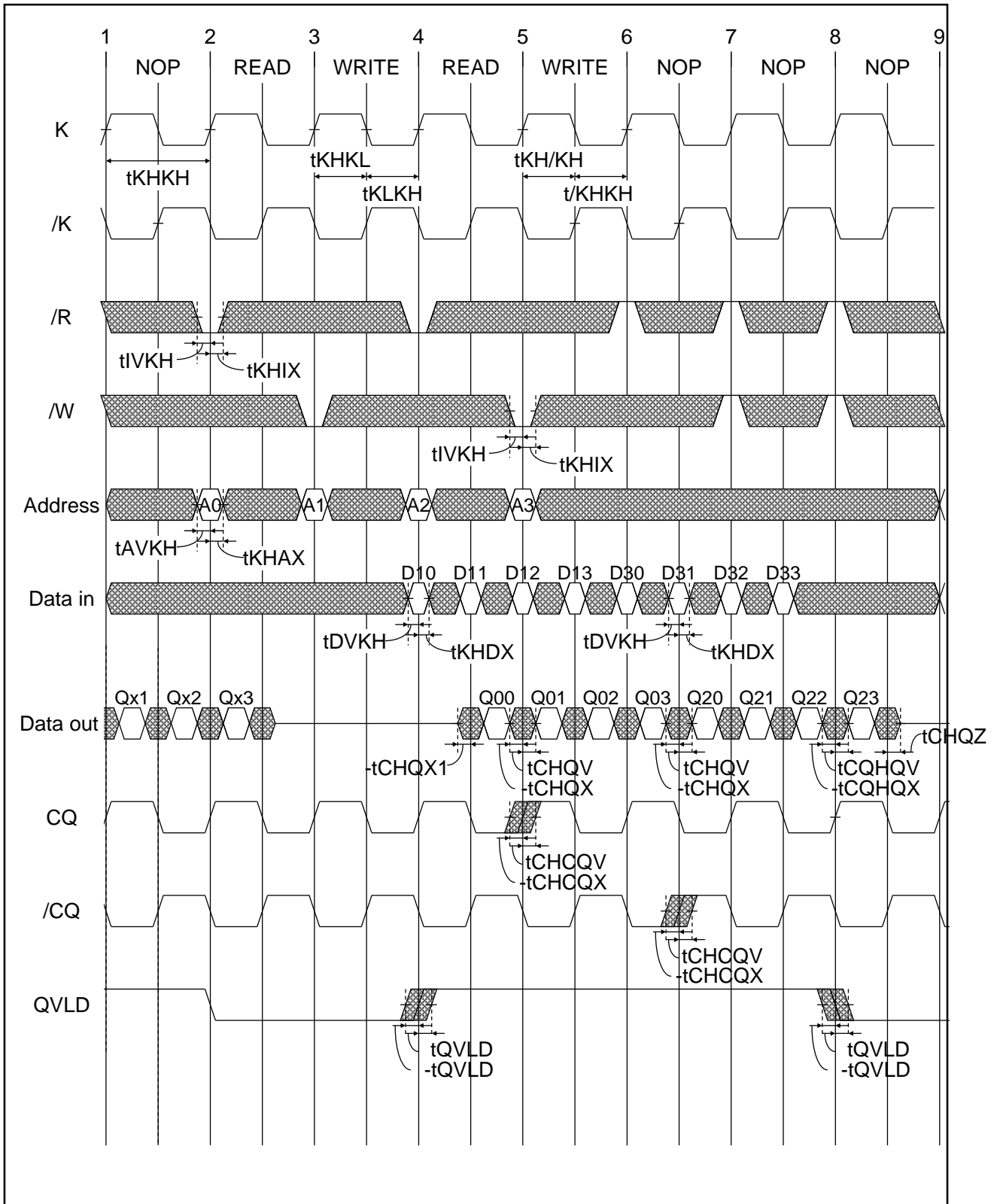

Notes:

1. Q00 refers to output from address A0+0. Q01 refers to output from the next internal burst address following A0, i.e., A0+1.
2. Outputs are disabled (high-Z) N clock cycle after the last read cycle. Here, N = Read Latency + Burst Length × 0.5.
3. In this example, if address A2 = A1, then data Q20 = D10, Q21 = D11. Write data is forwarded immediately as read results.
4. To control read and write operations, /BW signals must operate at the same timing as Data-in signals.

## JTAG Specification

These products support a limited set of JTAG functions as in IEEE standard 1149.1.

### Disabling the Test Access Port

It is possible to use this device without utilizing the TAP. To disable the TAP controller without interfering with normal operation of the device, TCK must be tied to  $V_{SS}$  to preclude mid level inputs.

TDI and TMS are internally pulled up and may be unconnected, or may be connected to VDD through a pull up resistor.

TDO should be left unconnected.

### Test Access Port (TAP) Pins

Symbol I/O	Pin assignments	Description	Notes
TCK	2R	Test clock input. All inputs are captured on the rising edge of TCK and all outputs propagate from the falling edge of TCK.	
TMS	10R	Test mode select. This is the command input for the TAP controller state machine.	
TDI	11R	Test data input. This is the input side of the serial registers placed between TDI and TDO. The register placed between TDI and TDO is determined by the state of the TAP controller state machine and the instruction that is currently loaded in the TAP instruction.	
TDO	1R	Test data output. Output changes in response to the falling edge of TCK. This is the output side of the serial registers placed between TDI and TDO.	

**Notes:**

The device does not have TRST (TAP reset). The Test-Logic Reset state is entered while TMS is held high for five rising edges of TCK. The TAP controller state is also reset on SRAM POWER-UP.

**TAP DC Operating Characteristics**

(Ta = 0 ~ +70°C @ R1Q\*A\*\*\*\*\*BG-\*\*R\*\* series)

(Ta = -40 ~ +85°C @ R1Q\*A\*\*\*\*\*BG-\*\*I\*\* series)

(V<sub>DD</sub> = 1.8V ±0.1V)

Parameter	Symbol	Min	Typ	Max	Unit	Notes
Input high voltage	V <sub>IH</sub>	+1.3	—	V <sub>DD</sub> + 0.3	V	
Input low voltage	V <sub>IL</sub>	-0.3	—	+0.5	V	
Input leakage current	I <sub>LI</sub>	-5.0	—	+5.0	μA	0 V ≤ V <sub>IN</sub> ≤ V <sub>DD</sub>
Output leakage current	I <sub>LO</sub>	-5.0	—	+5.0	μA	0 V ≤ V <sub>IN</sub> ≤ V <sub>DD</sub> , output disabled
Output low voltage	V <sub>OL1</sub>	—	—	0.2	V	I <sub>OLC</sub> = 100 μA
	V <sub>OL2</sub>	—	—	0.4	V	I <sub>OLT</sub> = 2 mA
Output high voltage	V <sub>OH1</sub>	1.6	—	—	V	I <sub>OHC</sub>   = 100 μA
	V <sub>OH2</sub>	1.4	—	—	V	I <sub>OHT</sub>   = 2 mA

Notes:

1. All voltages referenced to V<sub>SS</sub> (GND).
2. At power-up, V<sub>DD</sub> and V<sub>DDQ</sub> are assumed to be a linear ramp from 0V to V<sub>DD</sub>(min.) or V<sub>DDQ</sub>(min.) within 200ms. During this time V<sub>DDQ</sub> < V<sub>DD</sub> and V<sub>IH</sub> < V<sub>DDQ</sub>. During normal operation, V<sub>DDQ</sub> must not exceed V<sub>DD</sub>.

**TAP AC Test Conditions**

Parameter	Symbol	Conditions	Unit	Notes
Input timing measurement reference levels	$V_{REF}$	0.9	V	
Input pulse levels	$V_{IL}, V_{IH}$	0 to 1.8	V	
Input rise/fall time	$t_r, t_f$	$\leq 1.0$	ns	
Output timing measurement reference levels		0.9	V	
Test load termination supply voltage ( $V_{TT}$ )		0.9	V	
Output load		See figures		

**Input waveform**

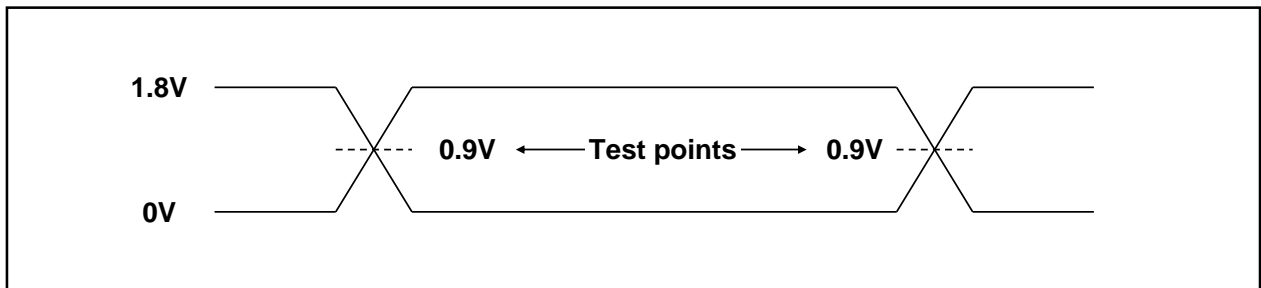

**Output waveform**

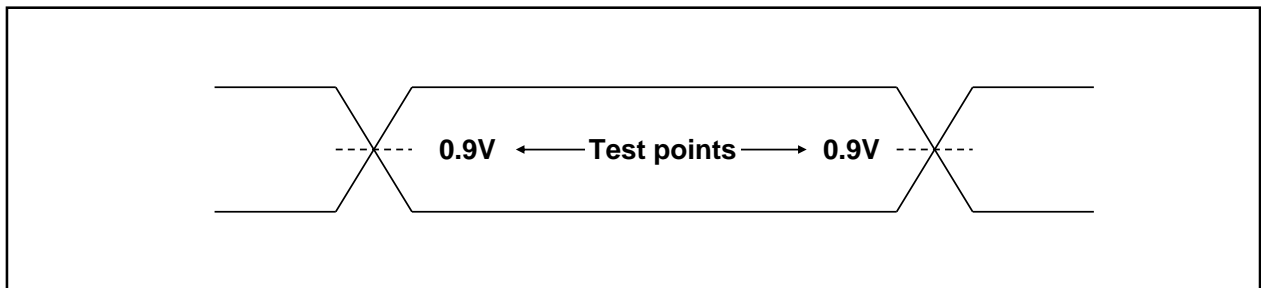

**Output load condition**

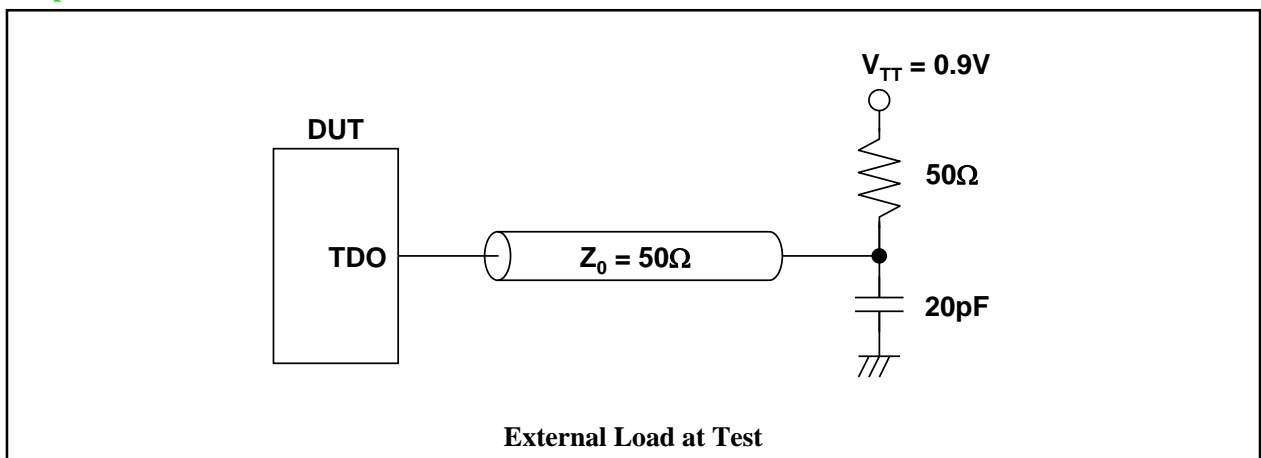

**TAP AC Operating Characteristics**

(Ta = 0 ~ +70°C @ R1Q\*A\*\*\*\*\*BG-\*\*R\*\* series)

(Ta = -40 ~ +85°C @ R1Q\*A\*\*\*\*\*BG-\*\*I\*\* series)

(V<sub>DD</sub> = 1.8V ±0.1V)

Parameter	Symbol	Min	Typ	Max	Unit	Notes
Test clock (TCK) cycle time	t <sub>THTH</sub>	50	—	—	ns	
TCK high pulse width	t <sub>THTL</sub>	20	—	—	ns	
TCK low pulse width	t <sub>TLTH</sub>	20	—	—	ns	
Test mode select (TMS) setup	t <sub>MVTH</sub>	5	—	—	ns	
TMS hold	t <sub>THMX</sub>	5	—	—	ns	
Capture setup	t <sub>CS</sub>	5	—	—	ns	1
Capture hold	t <sub>CH</sub>	5	—	—	ns	1
TDI valid to TCK high	t <sub>DVTH</sub>	5	—	—	ns	
TCK high to TDI invalid	t <sub>THDX</sub>	5	—	—	ns	
TCK low to TDO unknown	t <sub>TLQX</sub>	0	—	—	ns	
TCK low to TDO valid	t <sub>TLQV</sub>	—	—	10	ns	

Notes:

- t<sub>CS</sub> + t<sub>CH</sub> defines the minimum pause in RAM I/O pad transitions to assure pad data capture.

### TAP Controller Timing Diagram

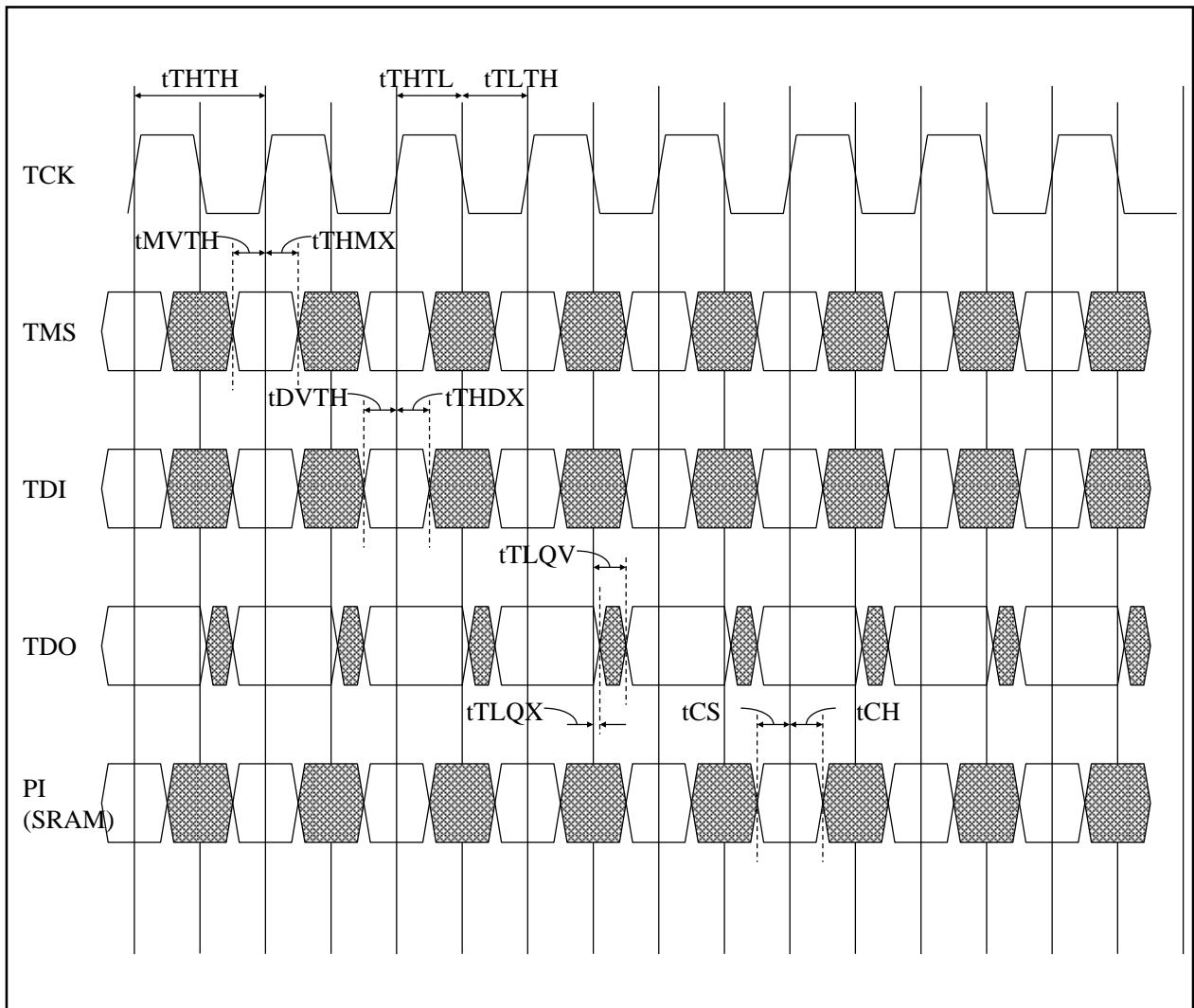

### Test Access Port Registers

Register name	Length	Symbol	Notes
Instruction register	3 bits	IR [2:0]	
Bypass register	1 bit	BP	
ID register	32 bits	ID [31:0]	
Boundary scan register	109 bits	BS [109:1]	

## TAP Controller Instruction Set

IR2	IR1	IR0	Instruction	Description	Notes
0	0	0	EXTEST	The EXTEST instruction allows circuitry external to the component package to be tested. Boundary scan register cells at output balls are used to apply test vectors, while those at input balls capture test results. Typically, the first test vector to be applied using the EXTEST instruction will be shifted into the boundary scan register using the PRELOAD instruction. Thus, during the Update-IR state of EXTEST, the output driver is turned on and the PRELOAD data is driven onto the output balls.	1, 2, 3, 5
0	0	1	IDCODE	The IDCODE instruction causes the ID ROM to be loaded into the ID register when the controller is in capture-DR mode and places the ID register between the TDI and TDO balls in shift-DR mode. The IDCODE instruction is the default instruction loaded in at power up and any time the controller is placed in the Test-Logic-Reset state.	
0	1	0	SAMPLE-Z	If the SAMPLE-Z instruction is loaded in the instruction register, all RAM outputs are forced to an inactive drive state (high-Z), moving the TAP controller into the capture-DR state loads the data in the RAMs input into the boundary scan register, and the boundary scan register is connected between TDI and TDO when the TAP controller is moved to the shift-DR state.	3, 4, 5
0	1	1	RESERVED	The RESERVED instructions are not implemented but are reserved for future use. Do not use these instructions.	
1	0	0	SAMPLE (/PRELOAD)	When the SAMPLE instruction is loaded in the instruction register, moving the TAP controller into the capture-DR state loads the data in the RAMs input and I/O buffers into the boundary scan register. Because the RAM clock(s) are independent from the TAP clock (TCK) it is possible for the TAP to attempt to capture the I/O ring contents while the input buffers are in transition (i.e., in a metastable state). Although allowing the TAP to SAMPLE metastable input will not harm the device, repeatable results cannot be expected. Moving the controller to shift-DR state then places the boundary scan register between the TDI and TDO balls.	3, 5
1	0	1	RESERVED	-	
1	1	0	RESERVED	-	
1	1	1	BYPASS	The BYPASS instruction is loaded in the instruction register when the bypass register is placed between TDI and TDO. This occurs when the TAP controller is moved to the shift-DR state. This allows the board level scan path to be shortened to facilitate testing of other devices in the scan path.	

## Notes:

1. Data in output register is not guaranteed if EXTEST instruction is loaded.
2. After performing EXTEST, power-up conditions are required in order to return part to normal operation.
3. RAM input signals must be stabilized for long enough to meet the TAPs input data capture setup plus hold time ( $t_{CS}$  plus  $t_{CH}$ ). The RAMs clock inputs need not be paused for any other TAP operation except capturing the I/O ring contents into the boundary scan register.
4. Clock recovery initialization cycles are required after boundary scan.
5. For R1QD, R1QE, R1QF, R1QK, R1QL, R1QM, R1QP series, ODT is disabled in EXTEST, SAMPLE-Z or SAMPLE mode.

Boundary Scan Order

Bit #	Ball ID	Signal names			Bit #	Ball ID	Signal names		
		x9	x18	x36			x9	x18	x36
1	6R	/C or NC or ODT	/C or NC or ODT	/C or NC or ODT	36	10E	D3	D6	D6
2	6P	C or QVLD	C or QVLD	C or QVLD	37	10D	NC	NC	D15
3	6N	SA	SA	SA	38	9E	NC	NC	Q15
4	7P	SA	SA	SA	39	10C	NC	Q7	Q7
5	7N	SA	SA	SA	40	11D	NC	D7	D7
6	7R	SA	SA	SA	41	9C	NC	NC	D16
7	8R	SA	SA	SA	42	9D	NC	NC	Q16
8	8P	SA	SA	SA	43	11B	Q4	Q8	Q8
9	9R	SA	SA	SA	44	11C	D4	D8	D8
10	11P	Q0	Q0	Q0	45	9B	NC	NC	D17
11	10P	D0	D0	D0	46	10B	NC	NC	Q17
12	10N	NC	NC	D9	47	11A	CQ	CQ	CQ
13	9P	NC	NC	Q9	48	10A	SA	NC	NC
14	10M	NC	Q1	Q1	49	9A	SA	SA	SA
15	11N	NC	D1	D1	50	8B	SA	SA	SA
16	9M	NC	NC	D10	51	7C	SA	SA	SA
17	9N	NC	NC	Q10	52	6C	NC	NC	NC
18	11L	Q1	Q2	Q2	53	8A	/R	/R	/R
19	11M	D1	D2	D2	54	7A	NC	NC	/BW1
20	9L	NC	NC	D11	55	7B	/BW	/BW0	/BW0
21	10L	NC	NC	Q11	56	6B	K	K	K
22	11K	NC	Q3	Q3	57	6A	/K	/K	/K
23	10K	NC	D3	D3	58	5B	NC	NC	/BW3
24	9J	NC	NC	D12	59	5A	NC	/BW1	/BW2
25	9K	NC	NC	Q12	60	4A	/W	/W	/W
26	10J	Q2	Q4	Q4	61	5C	SA	SA	SA
27	11J	D2	D4	D4	62	4B	SA	SA	SA
28	11H	ZQ	ZQ	ZQ	63	3A	SA	SA	NC
29	10G	NC	NC	D13	64	2A	NC	NC	NC
30	9G	NC	NC	Q13	65	1A	/CQ	/CQ	/CQ
31	11F	NC	Q5	Q5	66	2B	NC	Q9	Q18
32	11G	NC	D5	D5	67	3B	NC	D9	D18
33	9F	NC	NC	D14	68	1C	NC	NC	D27
34	10F	NC	NC	Q14	69	1B	NC	NC	Q27
35	11E	Q3	Q6	Q6	70	3D	NC	Q10	Q19



Boundary Scan Order

Bit #	Ball ID	Signal names			Bit #	Ball ID	Signal names		
		x9	x18	x36			x9	x18	x36
71	3C	NC	D10	D19	91	2L	Q7	Q15	Q24
72	1D	NC	NC	D28	92	3L	D7	D15	D24
73	2C	NC	NC	Q28	93	1M	NC	NC	D33
74	3E	Q5	Q11	Q20	94	1L	NC	NC	Q33
75	2D	D5	D11	D20	95	3N	NC	Q16	Q25
76	2E	NC	NC	D29	96	3M	NC	D16	D25
77	1E	NC	NC	Q29	97	1N	NC	NC	D34
78	2F	NC	Q12	Q21	98	2M	NC	NC	Q34
79	3F	NC	D12	D21	99	3P	Q8	Q17	Q26
80	1G	NC	NC	D30	100	2N	D8	D17	D26
81	1F	NC	NC	Q30	101	2P	NC	NC	D35
82	3G	Q6	Q13	Q22	102	1P	NC	NC	Q35
83	2G	D6	D13	D22	103	3R	SA	SA	SA
84	1H	/DOFF	/DOFF	/DOFF	104	4R	SA	SA	SA
85	1J	NC	NC	D31	105	4P	SA	SA	SA
86	2J	NC	NC	Q31	106	5P	SA	SA	SA
87	3K	NC	Q14	Q23	107	5N	SA	SA	SA
88	3J	NC	D14	D23	108	5R	SA	SA	SA
89	2K	NC	NC	D32	109	—	INTER- NAL	INTER- NAL	INTER- NAL
90	1K	NC	NC	Q32	—	—	—	—	—

Notes:

In boundary scan mode,

1. Clock balls (K, /K, C, /C) are referenced to each other and must be at opposite logic levels for reliable operation.
2. CQ and /CQ data are synchronized to the respective C and /C (except EXTEST, SAMPLE-Z).
3. If C and /C tied high, CQ is generated with respect to K and /CQ is generated with respect to /K (except EXTEST, SAMPLE-Z).



## Package Dimensions and Marking Information

Both Pb parts and Pb-free parts are available.

JEITA Package Code	Renesas Code	Previous Code	Mass (typ.)
P-LBGA165-15x17-1.00	PLBG0165FD-A	165FHE	0.6 g

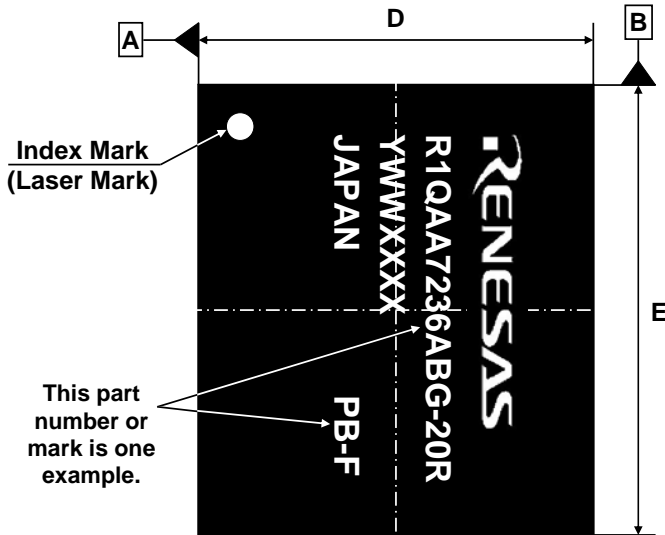

Top View

Marking Information	
1st row :	Vender name (RENESAS)
2nd row :	Part number
3rd row :	Y : Year code
	WW : Week code
	XXXX : Renesas internal use
4th row :	Country name (JAPAN)
	+ "None" --- Pb parts
	+ "PB-F" --- Pb-free parts

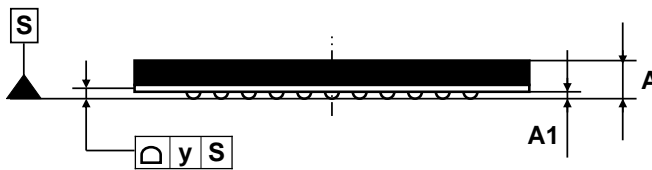

Side View

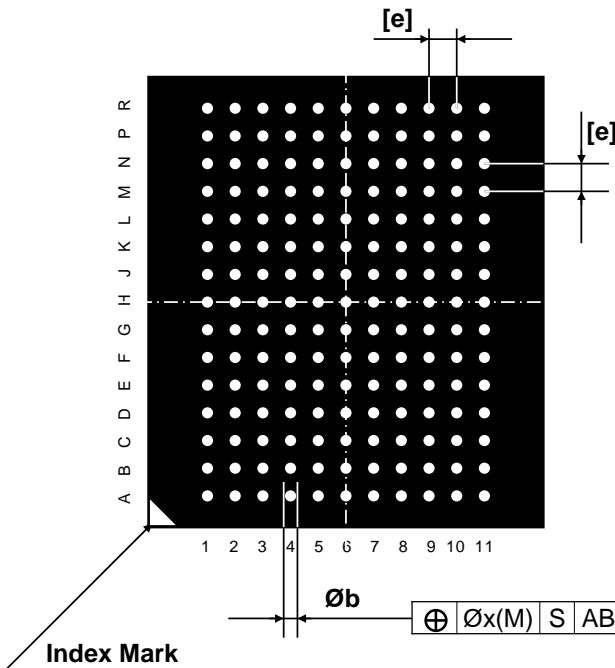

Bottom View

Reference Symbol	Dimension in mm		
	Min	Nom	Max
D	14.9	15.0	15.1
E	16.9	17.0	17.1
A	-	-	1.4
A1	0.27	0.32	0.37
[e]	-	1.0	-
b	0.45	0.5	0.55
x	-	-	0.2
y	-	-	0.15

## Revision History (1)

Rev.	Date	#	Comment
Rev. 0.00a	'08.10.08	1	Initial issue.
Rev. 0.00b	'08.10.09	1	Corrected typos in "DC Characteristics": VOH/VOL= VDDQ/2±1.12 → ±0.12.
Rev. 0.00c	'08.11.19	1	Added "Speed Bin Table". Added "ODT timing chart" to QDR11+ and DDR11+ series.
Rev. 0.00d	'08.11.28	1	Corrected typos in "General Description": ODT pin = Q0~Qn → D0~Dn.
		2	Updated "Recommended DC Operating Conditions": Vref =0.68~0.95V → 0.7~0.8V (11+ series).
		3	Added comment to "Thermal Resistance" section: These are reference values.
Rev. 0.00e	'08.12.07	1	Added "Generation Number Table".
Rev. 0.00f -1	'09.02.09	1	Changed Marking Name in "Part Number Definition Table".
		2	Added marking information to "Package Dimension Information" section.
		3	Corrected ODT On/Off timing in "ODT pin" table.
		4	Updated minimum frequency of QDR11+ and DDR11+ series.
		5	Changed pin name in "Pin Arrangement" of DDR11+ series: SA0/SA1 → NC.
		6	Added the row to "K Truth Table": RL=2.0 and RL=2.5.
Rev. 0.00g -1	'09.02.24	1	Updated SET-UP cycles: 11+ series DLL lock time = 20us → 2048 cycle.
		2	Added comment to "ODT on/off Timing Chart" section: ODT on/off switching timings are edge aligned with CQ or /CQ.
		3	Updated "Thermal Resistance".
Rev. 0.00h	'09.03.04	1	Added "-50" speed bin to QDR 11 B2 x18/x36 series.
Rev. 0.00i	'09.06.15	1	Updated "Package Dimensions": Mass=0.7→0.6g, A(max)=1.46→1.4mm.
		2	Updated "Operating/Standby Supply Currents".
Rev. 0.01a	'09.10.25	1	Added comment to "Power-up and Initialization Sequence" section: Apply Vref after Vddq or at the same time as Vddq.
		2	Updated "Speed Bin Table".
Rev. 0.02a	'10.02.01	1	Added "Renesas QDR SRAM Homepage URL" to notes of front page.
		2	Updated "Power-up and Initialization Sequence".
		3	Updated "DLL Constraints".
		4	Updated "Operating Supply Current" and "Standby Supply Current".
		5	Updated "Thermal Resistance".
		6	Changed remarks of "AC Characteristics" on "Control signals".
Rev. 0.03a	'10.04.01	1	Changed company name, RENESAS logo and base color from those of Renesas Technology to Renesas Electronics.
		2	Changed vender name marking in "Package Dimensions and Marking Information" section.
		3	Added "A" generation to 72M series.
Rev. 0.04a	'10.06.10	1	Changed the pin description for NC pin.
		2	Changed note 4 of "TAP Controller Instruction Set": "Clock recovery initialization cycles are required after boundary scan"
Rev. 0.05a	'10.06.25	1	Changed Vddq range of 11+ series: Vddq=1.5±0.1V → 1.4V ~ Vdd.
		2	Added Note.8 and Note.9 to AC Characteristics table for 11+ series.
		3	Updated Speed Bin Table for 144M.
Rev. 0.05b	'10.07.02	1	Added Note.2 to Generation Number Table.
		2	Updated Speed Bin Table for 36M and 72M.
Rev. 0.05c	'10.07.24	1	Updated Operating Supply Current and Standby Supply Current Table for 36M and 72M.
Rev. 0.06a	'10.09.20	1	Changed Initialization Sequence: Initial cycle of 11+ series = 2048cycles → 20us.
Rev. 0.07a	'10.10.06	1	Added Note.9 to AC Characteristics table for 11 series.
Rev. 0.07b	'10.10.30	1	Updated AC Characteristics for the series of RL=2.0.
		2	Updated Speed Bin Table for 72M/36M/144M.
		3	Added R1QNA, R1QPA series to 144M QDR lineup.
		4	Changed JTAG/ID Register (ID Code): #27="0": 36M&72M w/o ODT, 144M, 288M "1": 36M&72M w/ ODT #23="0": 144M&288M w/o ODT, 36M, 72M "1": 144M&288M w/ ODT #(26, 25, 24)="100"→"101" (144M), "101"→"110" (288M).

**Revision History (2)**

Rev.	Date	#	Comment
Rev. 0.08a	11.05.23	1	Added Note.7 to tQVLD in AC Characteristics table for II+ series.
		2	Changed description of tQVLD in AC Characteristics table for RL=2 series: CQ high to QVLD valid → /CQ high to QVLD valid.
		3	Updated Remarks 4 of AC Characteristics table.
		4	Updated tKHKH(max) in AC Characteristics table for QDR11+ B2 series.
		5	Added 13 x15 mm package lineup to 36M II+ & 72M II/II+ series.
		6	Copyright: (c)2010 → (c)2011

## NOTES:

1. This document is provided for reference purposes only so that Renesas customers may select the appropriate Renesas products for their use. Renesas neither makes warranties or representations with respect to the accuracy or completeness of the information contained in this document nor grants any license to any intellectual property rights or any other rights of Renesas or any third party with respect to the information in this document.
2. Renesas shall have no liability for damages or infringement of any intellectual property or other rights arising out of the use of any information in this document, including, but not limited to, product data, diagrams, charts, programs, algorithms, and application circuit examples.
3. You should not use the products or the technology described in this document for the purpose of military applications such as the development of weapons of mass destruction or for the purpose of any other military use. When exporting the products or technology described herein, you should follow the applicable export control laws and regulations, and procedures required by such laws and regulations.
4. All information included in this document such as product data, diagrams, charts, programs, algorithms, and application circuit examples, is current as of the date this document is issued. Such information, however, is subject to change without any prior notice. Before purchasing or using any Renesas products listed in this document, please confirm the latest product information with a Renesas sales office. Also, please pay regular and careful attention to additional and different information to be disclosed by Renesas such as that disclosed through our website. (<http://www.renesas.com>)
5. Renesas has used reasonable care in compiling the information included in this document, but Renesas assumes no liability whatsoever for any damages incurred as a result of errors or omissions in the information included in this document.
6. When using or otherwise relying on the information in this document, you should evaluate the information in light of the total system before deciding about the applicability of such information to the intended application. Renesas makes no representations, warranties or guaranties regarding the suitability of its products for any particular application and specifically disclaims any liability arising out of the application and use of the information in this document or Renesas products.
7. The products described in this document are intended for usage in general electronics applications (computer, personal equipment, office equipment, measuring equipment, industrial robotics, domestic appliances, etc.). The products are not designed, manufactured, tested or warranted for applications or otherwise in systems the failure or malfunction of which may cause a direct threat to human life or create a risk of human injury or which require especially high quality and reliability such as safety systems, or equipment or systems for transportation and traffic, healthcare, combustion control, aerospace and aeronautics, nuclear power, or undersea communication transmission. Unintended usage of the products shall be made at the customer's own risk. Renesas shall have no liability for damages arising out of the uses set forth above.
8. Notwithstanding the preceding paragraph, you should not use Renesas products for the purposes listed below:
  - (1) artificial life support devices or systems
  - (2) surgical implantations
  - (3) healthcare intervention (e.g., excision, administration of medication, etc.)
  - (4) any other purposes that pose a direct threat to human lifeRenesas shall have no liability for damages arising out of the uses set forth in the above and purchasers who elect to use Renesas products in any of the foregoing applications shall indemnify and hold harmless Renesas Electronics Corp., its affiliated companies and their officers, directors, and employees against any and all damages arising out of such applications.
9. You should use the products described herein within the range specified by Renesas, especially with respect to the maximum rating, operating supply voltage range, movement power voltage range, heat radiation characteristics, installation and other product characteristics. Renesas shall have no liability for malfunctions or damages arising out of the use of Renesas products beyond such specified ranges.
10. Although Renesas endeavors to improve the quality and reliability of its products, IC products have specific characteristics such as the occurrence of failure at a certain rate and malfunctions under certain use conditions. Please be sure to implement safety measures to guard against the possibility of physical injury, and injury or damage caused by fire in the event of the failure of a Renesas product, such as safety design for hardware and software including but not limited to redundancy, fire control and malfunction prevention, appropriate treatment for aging degradation or any other applicable measures. Among others, since the evaluation of microcomputer software alone is very difficult, please evaluate the safety of the final products or system manufactured by you.
11. In case Renesas products listed in this document are detached from the products to which the Renesas products are attached or affixed, the risk of accident such as swallowing by infants and small children is very high. You should implement safety measures so that Renesas products may not be easily detached from your products. Renesas shall have no liability for damages arising out of such detachment.
12. This document may not be reproduced or duplicated, in any form, in whole or in part, without prior written approval from Renesas.
13. Please contact a Renesas sales office if you have any questions regarding the information contained in this document, Renesas semiconductor products, or if you have any other inquiries.

**Renesas Sales Offices**<http://www.renesas.com>Refer to "<http://www.renesas.com/>" for the latest and detailed information.**Renesas Electronics America Inc.**2880 Scott Boulevard Santa Clara, CA 95050-2554, U.S.A.  
Tel: +1-408-588-6000, Fax: +1-408-588-6130**Renesas Electronics Canada Limited**1101 Nicholson Road, Newmarket, Ontario L3Y 9C3, Canada  
Tel: +1-905-898-5441, Fax: +1-905-898-3220**Renesas Electronics Europe Limited**Dukes Meadow, Millboard Road, Bourne End, Buckinghamshire,  
SL8 5FH, U.K  
Tel: +44-1628-585-100, Fax: +44-1628-585-900**Renesas Electronics Europe GmbH**Arcadiastrasse 10, 40472 Düsseldorf, Germany  
Tel: +49-211-6503-0, Fax: +49-211-6503-1327**Renesas Electronics (China) Co., Ltd.**7th Floor, Quantum Plaza, No.27 ZhiChunLu Haidian District,  
Beijing 100083, P.R.China  
Tel: +86-10-8235-1155, Fax: +86-10-8235-7679**Renesas Electronics (Shanghai) Co., Ltd.**Unit 204, 205, AZIA Center, No.1233 Lujiazui Ring Rd., Pudong District,  
Shanghai 200120, China  
Tel: +86-21-5877-1818, Fax: +86-21-6887-7858 / -7898**Renesas Electronics Hong Kong Limited**Unit 1601-1613, 16/F., Tower 2, Grand Century Place,  
193 Prince Edward Road West, Mongkok, Kowloon, Hong Kong  
Tel: +852-2886-9318, Fax: +852 2886-9022/9044**Renesas Electronics Taiwan Co., Ltd.**7F, No. 363 Fu Shing North Road Taipei, Taiwan, R.O.C.  
Tel: +886-2-8175-9600, Fax: +886 2-8175-9670**Renesas Electronics Singapore Pte. Ltd.**1 harbourFront Avenue, #06-10, Keppel Bay Tower, Singapore 098632  
Tel: +65-6213-0200, Fax: +65-6278-8001**Renesas Electronics Malaysia Sdn.Bhd.**Unit 906, Block B, Menara Amcorp, Amcorp Trade Centre, No. 18,  
Jln Persiaran Barat, 46050 Petaling Jaya, Selangor Darul Ehsan, Malaysia  
Tel: +60-3-7955-9390, Fax: +60-3-7955-9510**Renesas Electronics Korea Co., Ltd.**11F., Samik Laviel' or Bldg., 720-2 Yeoksam-Dong, Kangnam-Ku,  
Seoul 135-080, Korea  
Tel: +82-2-558-3737, Fax: +82-2-558-5141