

REV.	ECN NO.	DESCRIPTION	DATE	DESIGN
A1.	/.	增加网口弹高尺寸管控	20.09.04	Yang
		HD	22.06.09	LZR

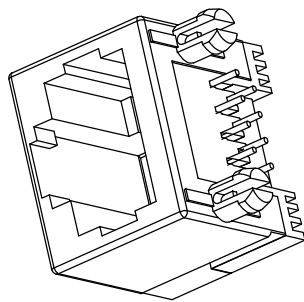
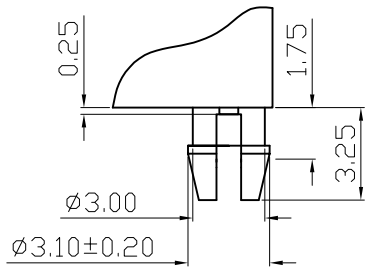
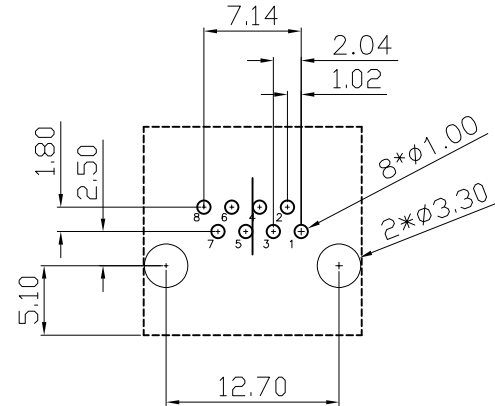
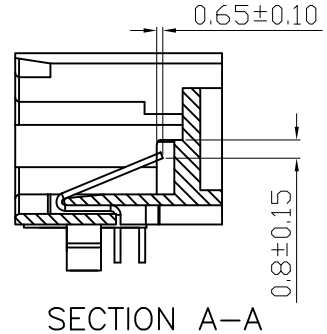
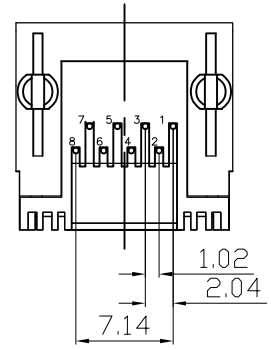
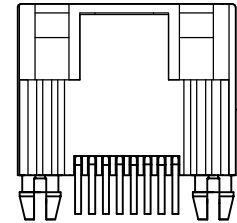
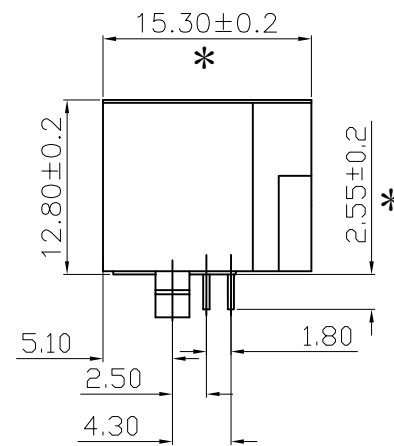
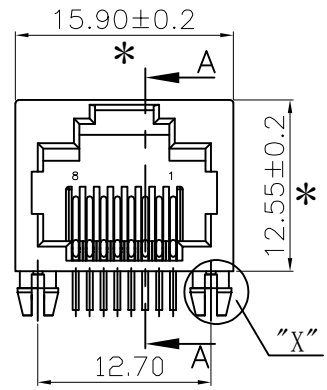

NOTES:

- MATERIAL:
 - HOUSING: PBT ,COLOR IS BLACK UL94-V0;
 - CONTACT: PHOSPHOR BRONZE,φ0.46±0.02mm;
- FINISH: PLATED GOLD ,AU 0.5U” NI 50U”;
- RECINNEBDED PCB THICKNESS: 1.60mm;
- ELECTRICAL:
 - VOLTAGE RATING: 125 VAC RMS;
 - CURRENT RATING: 1.5 AMP;
 - CONTACT RESISTANCE: 30MILLIOHMS MAX.;
 - WITHSTAND VOLTAGE: 1000 VAC RMS 50(60)Hz,1MIN.;
 - INSULATION RESISTANCE: 1000MEGOHMS MIN @500V DC;
- MECHANICAL:
 - MATING/UNMATING FORCE: 20.02N MAX.;
 - RETENTION STRENGTH: 77.4N MIN.;
 - OPERATING LIFE: 750 CYCLES MIN.;
- SALT SPRAY TEST: 12H;
- SOLDERABILITY: 245±5°C,5±0.5S;
- RESISTANCE TO SOLDER: 265±0.5°C,5±0.1S;
- ENVIRONMENTAL:
 - STORAGE TEMPERATURE RANGE: -40°C~+85°C;
 - OPERATION TEMPERATURE RANGE: -25°C~+70°C;
- MATES WITH:MODULAR PLUGS THAT CONFORM TO FCC REGULATION PART 68.500;
- THE MARK WITH "*" IS THE KEY INSPECTION DIMENSION FOR QC.

B	端子	磷铜	镀镍 镀金(G/F)	
A	底座	PBT	黑色	
序号	品名	材质	电镀/颜色	备注

深圳市虹成电子有限公司

UNLESS OTHERWISE, GENERAL TOLERANCE: X. xxx ±0.10 X. xx ±0.20 X. x ±0.30	NAME: RJ45全塑单口带后塞		P/N: HC-WK88-H16-QS	
	THIRD ANGLE PROJECTION		DWG NO:	
ANGULAR: X. xx° ±1° X. x° ±3° X. ° ±5°	UNIT: MM	SCALE: 1:1	SIZE: A4	SHEET: 1/1
DRAWN: Lihui	CHECKED: Yangguangrong		APPROVED: Tangguanlin	