

April 1995

30A, 400V - 600V Ultrafast Diodes

Features

- Ultrafast with Soft Recovery Characteristic ($t_{RR} < 55\text{ns}$)
- +175°C Rated Junction Temperature
- Reverse Voltage Up to 600V
- Avalanche Energy Rated

Applications

- Switching Power Supply
- Power Switching Circuits
- General Purpose

Description

RURP3010, RURP3015, RURP3020 are ultrafast diodes ($t_{RR} < 55\text{ns}$) with soft recovery characteristics. They have a low forward voltage drop and are of planar, silicon nitride passivated, ion-implanted, epitaxial construction.

These devices are intended for use as energy steering/clamping diodes and rectifiers in a variety of switching power supplies and other power switching applications. Their low stored charge and ultrafast recovery with soft recovery characteristics minimizes ringing and electrical noise in many power switching circuits thus reducing power loss in the switching transistor.

PACKAGING AVAILABILITY

PART NUMBER	PACKAGE	BRAND
RURP3040	TO-220AC	RURP3040
RURP3050	TO-220AC	RURP3050
RURP3060	TO-220AC	RURP3060

NOTE: When ordering, use the entire part number.

Package

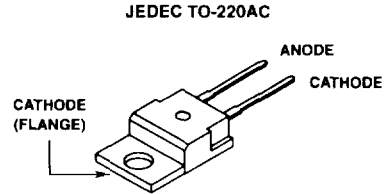

Symbol



Absolute Maximum Ratings $T_C = +25^\circ\text{C}$, Unless Otherwise Specified

	RURP3040	RURP3050	RURP3060
Peak Repetitive Reverse Voltage..... V_{RRM}	400V	500V	600V
Working Peak Reverse Voltage..... V_{RWM}	400V	500V	600V
DC Blocking Voltage..... V_R	400V	500V	600V
Average Rectified Forward Current (Total device forward current at rated V_R and $T_C = +150^\circ\text{C}$)..... $I_{F(AV)}$	30A	30A	30A
Peak Forward Repetitive Current (Rated V_R , square wave 20kHz)..... I_{FRM}	70A	70A	70A
Nonrepetitive Peak Surge Current (Surge applied at rated load condition halfwave 1 phase 60Hz)..... I_{FSM}	325A	325A	325A
Operating and Storage Temperature..... T_{STG}, T_J	-55°C to +175°C	-55°C to +175°C	-55°C to +175°C

Specifications RURP3040, RURP3050, RURP3060

Electrical Specifications $T_C = +25^\circ\text{C}$, Unless Otherwise Specified

SYMBOL	TEST CONDITION	LIMITS									UNITS
		RURP3040			RURP3050			RURP3060			
		MIN	TYP	MAX	MIN	TYP	MAX	MIN	TYP	MAX	
V_F	$I_F = 30\text{A}$ $T_C = +150^\circ\text{C}$	-	-	1.30	-	-	1.30	-	-	1.30	V
	$I_F = 30\text{A}$ $T_C = +25^\circ\text{C}$	-	-	1.50	-	-	1.50	-	-	1.50	V
I_R at $T_C = +150^\circ\text{C}$	$V_R = 400\text{V}$	-	-	1	-	-	-	-	-	-	mA
	$V_R = 500\text{V}$	-	-	-	-	-	1	-	-	-	mA
	$V_R = 600\text{V}$	-	-	-	-	-	-	-	-	1	mA
I_R at $T_C = +25^\circ\text{C}$	$V_R = 400\text{V}$	-	-	500	-	-	-	-	-	-	μA
	$V_R = 500\text{V}$	-	-	-	-	-	500	-	-	-	μA
	$V_R = 600\text{V}$	-	-	-	-	-	-	-	-	500	μA
t_{RR}	$I_F = 1\text{A}$	-	-	55	-	-	55	-	-	55	ns
	$I_F = 30\text{A}$	-	-	60	-	-	60	-	-	60	ns
t_A	$I_F = 1\text{A}$	-	20	-	-	20	-	-	20	-	ns
	$I_F = 30\text{A}$	-	38	-	-	38	-	-	38	-	ns
t_B	$I_F = 1\text{A}$	-	15	-	-	15	-	-	15	-	ns
	$I_F = 30\text{A}$	-	20	-	-	20	-	-	20	-	ns
$R_{\theta JC}$		-	-	1.2	-	-	1.2	-	-	1.2	$^\circ\text{C/W}$
E_{AVL}	See Figure 7 and 8	-	-	20	-	-	20	-	-	20	mJ

DEFINITIONS

V_F = Instantaneous forward voltage ($p_w = 300\mu\text{s}$, $D = 2\%$).

I_R = Instantaneous reverse current.

t_{RR} = Reverse recovery time at $dI_F/dt = 100\text{A}/\mu\text{s}$ (See Figure 2), summation of $t_A + t_B$.

t_A = Time to reach peak reverse current at $dI_F/dt = 100\text{A}/\mu\text{s}$ (See Figure 2).

t_B = Time from peak I_{RM} to projected zero crossing of I_{RM} based on a straight line from peak I_{RM} through 25% of I_{RM} (See Figure 2).

$R_{\theta JC}$ = Thermal resistance junction to case.

E_{AVL} = Controlled avalanche energy (See Figures 7 and 8).

p_w = pulse width.

D = duty cycle.

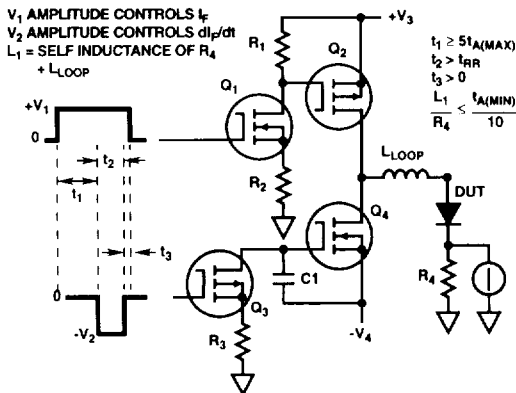

FIGURE 1. t_{RR} TEST CIRCUIT

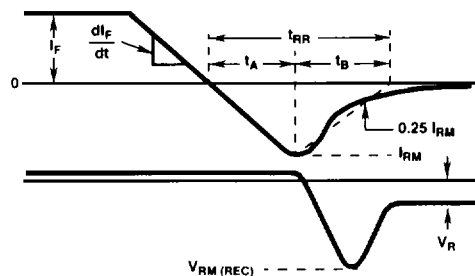

FIGURE 2. DEFINITIONS OF t_{RR} , t_A AND t_B

5
ULTRAFAST
SINGLE DIODES

Typical Performance Curves

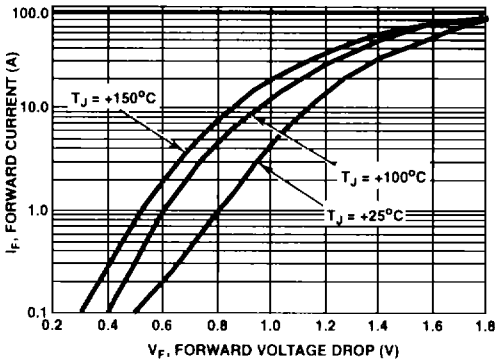

FIGURE 3. FORWARD VOLTAGE vs FORWARD CURRENT CHARACTERISTIC

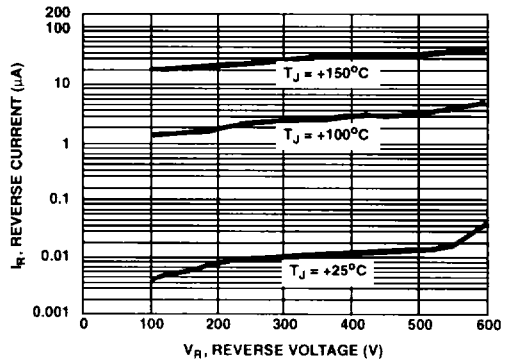

FIGURE 4. REVERSE VOLTAGE vs REVERSE CURRENT CHARACTERISTIC

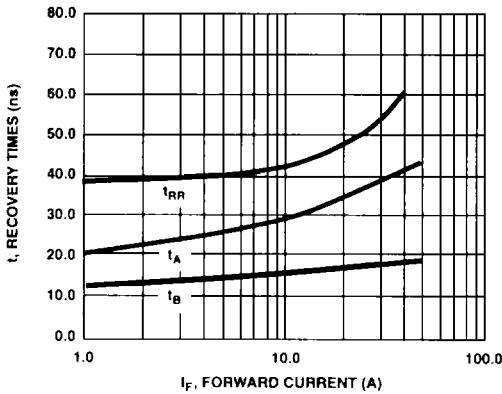

FIGURE 5. TYPICAL t_{RR} , t_A AND t_B CURVES vs FORWARD CURRENT

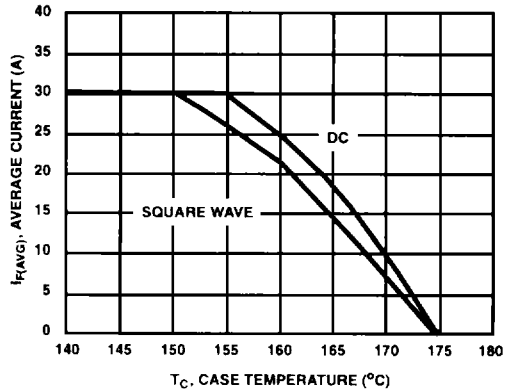

FIGURE 6. TYPICAL CURRENT DERATING CURVE vs CASE TEMPERATURE

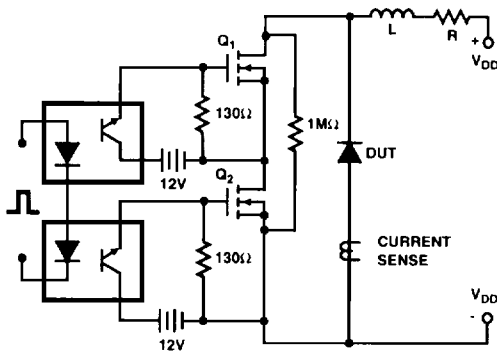

FIGURE 7. AVALANCHE ENERGY TEST CIRCUIT

$$I_{L\text{peak}} = 1\text{A}, L = 40\text{mH}, R < 0.1\Omega, E_{AVL} = (1/2) L I^2 [V_{AVL} / (V_{AVL} - V_{DD})]$$

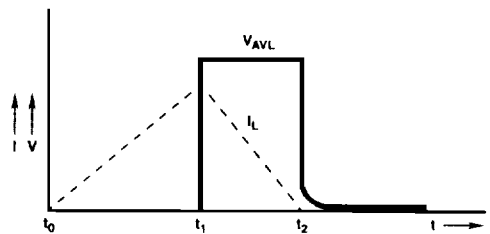

FIGURE 8. CURRENT VOLTAGE WAVEFORM