

PRODUCT NUMBER  
SEE TABLE

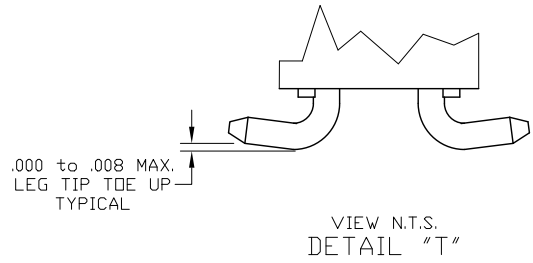
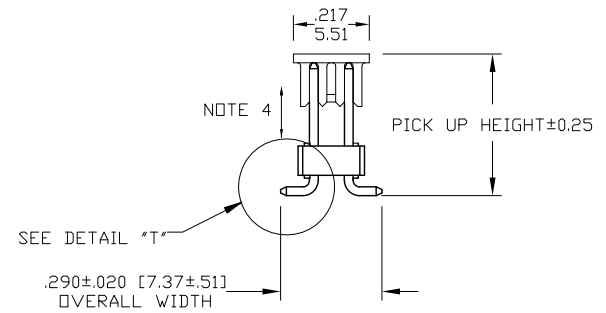
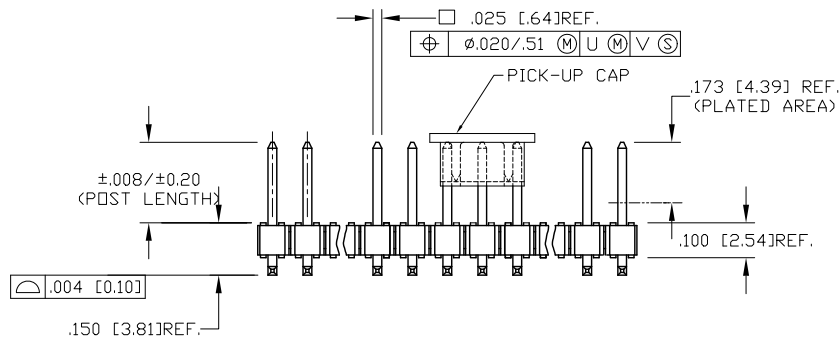
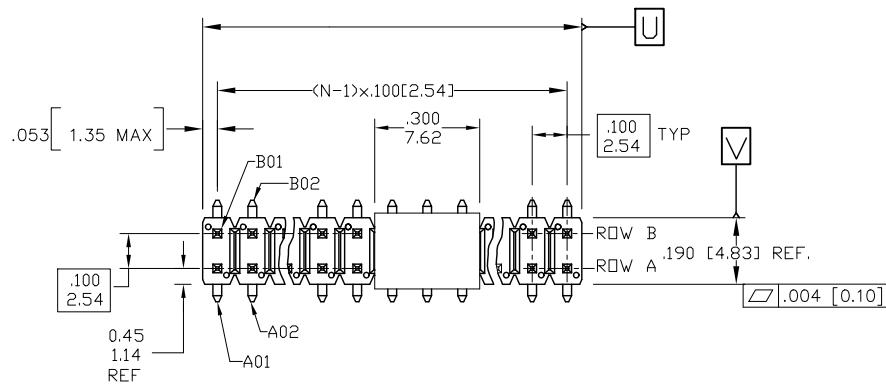

Mat'l. code NOTES 1 & 2		surface ISO 1302 ✓	tolerance ISO 406 ISO 1101	projection INCH/MM	product family BERGSTIK
ltr	ecn no	dr	date	tolerances unless otherwise specified	title .100 UNSHROUDED HDR. DOUL ROW VERT. SMT.
A	--	MZ	09/14/15	angles linear	scale 1:1
B	ELX-N-40285	MKX	03/05/21	0°±2°	
				dr	MIKE ZHOU 09/08/15
				enr	MIKE ZHOU 09/08/15
				chr	ZHENGKUN HU 09/08/15
				appd	TIM YAO 09/08/15
sheet	revision	B	B		
index	sheet	1	2		
				dwg no 10125394 sheet 1 of 2 size A3 type Product Customer Drawing	

PRODUCT NUMBER  
10125394 - X X X X X LF

PLATING  
T=100μ\*[2.5μ]TIN  
ON CONTACT AREA  
AND ON TAIL(SEE NOTE 10)

LEAD FREE OPTION NOTE 8

PACKAGING TYPE, NOTE 5

POSITIONS PER ROW  
02 TO 20

LEAD STYLE	POST LENGTH	PICK UP HEIGHT
08	0.230/5.84	10.29
30	0.318/8.08	12.53

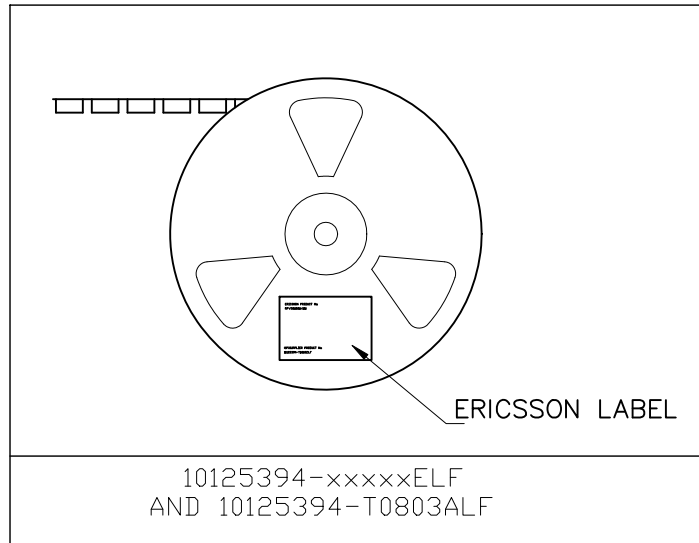

NOTES:

- HOUSING MAT'L: HIGH TEMPERATURE THERMOPLASTIC.  
FLAME RETARDANT PER UL 94V-0  
COLOR: BLACK  
  
THESE PART NUMBERS WILL WITHSTAND EXPOSURE  
TO 260° C PEAK TEMPERATURE FOR 20 SECONDS IN  
WAVE SOLDER, INFRA-RED OR VAPOR PHASE SOLDER PROCESS.
- PIN MATERIAL: COPPER ALLOY
- TO DETERMINE DIMENSIONS:  
N = NUMBER OF POSITIONS ROW.  
EXAMPLE: 10 PDS., N x .100/2.54=1.00/25.4
- 2LBS/0.9KG MIN. PIN RETENTION IN EITHER DIRECTION.
- PACKAGING: NONE =POLY BAGS WITHOUT PICKUP CAP.  
P =TUBES WITH PICKUP CAPS.  
A =TAPE AND REEL WITH PICKUP CAPS.  
NOTE 10125394-T0803ALF NEED WITH ERICSSON LABEL  
E =TAPE AND REEL WITH PICKUP CAPS FOR ERICSSON AND WITH SPECIAL LABEL
- UNDERPLATING: 50μ\*/1.2μm Ni.
- PIN TIPS ON Sn PLATED PRODUCT MAY HAVE BARE METAL ON TWO SIDES,  
BOTH ENDS.
- PART NUMBERS WITH "LF" SUFFIX AT THE END ARE LEAD FREE.
- THESE PRODUCTS MEETS EUROPEAN UNION DIRECTIVES AND OTHER  
COUNTRY REGULATION AS DESCRIBED IN GS-22-008.
- THIS PRODUCT HAS 100% PURE TIN PLATING IN THE INTERFACE AND  
HAS NOT BEEN TESTED FOR WHISKER GROWTH IN ALL INTERCONNECT  
ENVIRONMENTS."

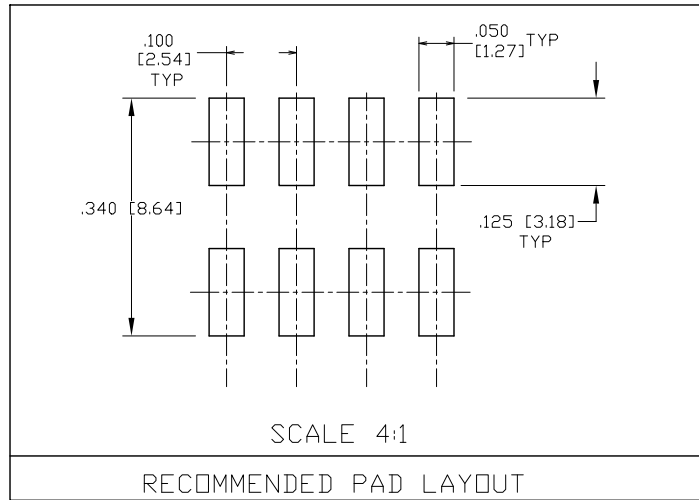

Mat'l. code NOTES 1 & 2	surface ISO 1302 ✓	tolerance ISO 406 ISO 1101	projection 	product family BERGSTIK
ltr	ecn no	dr	date	tolerances unless otherwise specified
B				angles linear XXL01/XXL03 XXXL005/XXXL013 XXXXL0020 XXXL0051
				0°±2°
		dr	MIKE ZHOU	09/08/15
		enr	MIKE ZHOU	09/08/15
		chr	ZHENGKUN HU	09/08/15
		appd	TIM YAO	09/08/15
sheet index	revision sheet			

title .100 UNSHROUDED HDR. DOUL ROW VERT. SMT.	scale 1:1	Amphenol FCI
dwg no 10125394	sheet 2 of 2	size A3
type Product Customer Drawing		