

DATA SHEET

CURRENT SENSOR - LOW TCR

4 Termination

PS Series

5%, 1%, 0.5%

0306/0612

RoHS compliant & Halogen free



SCOPE

This specification describes PS series 4-terminal current sensor - low TCR chip resistors with lead-free terminations made by metal alloy process.

APPLICATIONS

- Battery pack
- Inverter/Converter (DC-DC/AC-DC/DC-AC)
- Consumer electronics
- Laptops

FEATURES

- This product with lead-free terminations meet RoHS requirements
- High component and equipment reliability
- Ultra low resistance and narrow tolerance suitable for current detection

ORDERING INFORMATION - GLOBAL PART NUMBER

Global part numbers are identified by the series, size, tolerance, packing type, temperature coefficient, taping reel and resistance value.

GLOBAL PART NUMBER

PS XXXX X X X XX XXXX L
 (1) (2) (3) (4) (5) (6) (7)

(1) SIZE

0306 / 0612

(2) TOLERANCE

D=±0.5% (10mΩ & 20mΩ)
 F = ±1%
 J = ±5%

(3) PACKAGING TYPE

K= Embossed taping reel
 R = Paper taping reel

(4) TEMPERATURE COEFFICIENT OF RESISTANCE

M = ±75ppm/°C
 F = ±100ppm/°C
 L = ±150ppm/°C
 G = ±200ppm/°C
 P = ±300ppm/°C

(5) TAPING REEL

07 / 7W / 7T= 7 inch dia. Reel and specific rated power.
 Detailed power rating are shown in the Table 2.

(6) RESISTANCE VALUE

0.5mΩ to 100mΩ
 There are 3~5 digits indicated the resistance value. Letter R is decimal point.
 Detailed coding rules of resistance are shown in the table of "Resistance rule of global part number".

(7) DEFAULT CODE

Letter L is the system default code for ordering only. (Note)

Resistance rule of global part number	
Resistance code rule	Example
0RXXX	0R001 = 1mΩ
(0UX)	0R1 = 100mΩ
	0U5 = 0.5mΩ

ORDERING EXAMPLE

The ordering code of a PS0306 1W chip resistor, value 0.003 Ω with ±1% tolerance, supplied in 7-inch tape reel is:
PS0306FRL0R003L

NOTE

I. All our RSMD products are RoHS compliant. "LFP" of the internal 2D reel label mentions "Lead-Free Process"

MARKING

PS0306/0612



Outlines

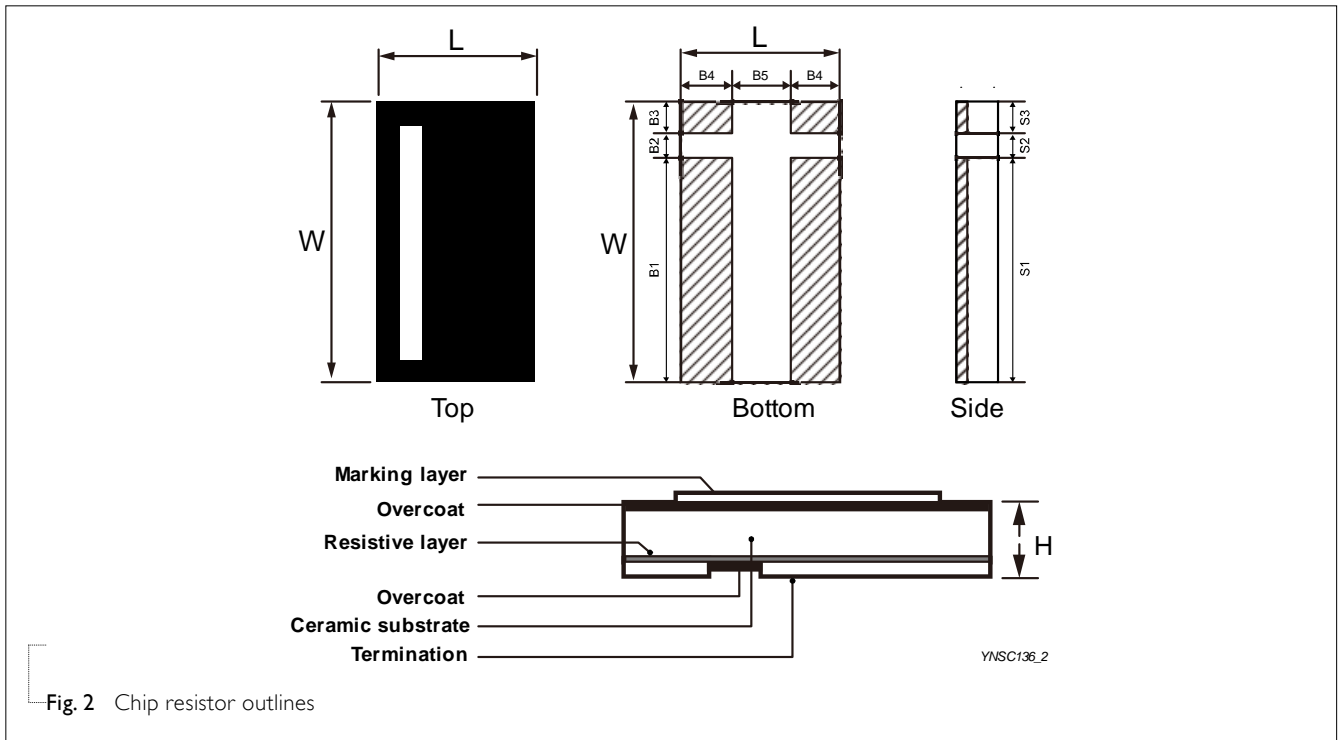

DIMENSION

Table 1

TYPE	L (mm)	W (mm)	B1/S1 (mm)	B2/S2 (mm)	B3/S3 (mm)	B4 (mm)	B5 (mm)	H (mm)
PS0306	0.80±0.15	1.60±0.20	1.10±0.20	0.25±0.10	0.25±0.10	0.20±0.10	0.40±0.20	0.50±0.20
PS0612	1.60+0.15/-0.20	3.20±0.20	2.20±0.20	0.50±0.20	0.50±0.20	0.45±0.20	0.70±0.20	(0.5~1mΩ) 0.70±0.20
								(2~10mΩ) 0.60±0.20
								(12~100mΩ) 0.50±0.20

Note:

1. For relevant physical dimensions, please refer to construction outlines.
2. Please contact with sales offices, distributors and representatives in your region before ordering.

ELECTRICAL CHARACTERISTICS

Table 2

SERIES	SIZE	POWER RATING	TOLERANCE	RESISTANCE RANGE	TEMPERATURE COEFFICIENT OF RESISTANCE
PS	0306	1/4W	± 0.5%(10, 20mΩ) ± 1%, ± 5%	2mΩ ≤ R < 5mΩ	± 150ppm/°C
		1/3W		5mΩ ≤ R ≤ 100mΩ	± 75ppm/°C ± 100ppm/°C
		1/2W		0.5mΩ	± 300ppm/°C
	0612	1W		1mΩ	± 150ppm/°C
				2mΩ ≤ R ≤ 9mΩ	± 100ppm/°C
				14mΩ ≤ R ≤ 100mΩ	± 100ppm/°C
				10mΩ ≤ R ≤ 13mΩ	± 200ppm/°C

Note: Please contact with sales offices, distributors and representatives in your region before ordering.

FUNCTIONAL DESCRIPTION

OPERATING TEMPERATURE RANGE

PS0612 0.5mΩ ≤ R ≤ 10mΩ -55°C to +155°C
 12mΩ ≤ R ≤ 100mΩ -55°C to +125°C
 PS0306 -55°C to +125°C

POWER RATING

Standard rated power at 70°C

RATED VOLTAGE

The DC or AC (rms) continuous working voltage corresponding to the rated power is determined by the following formula:

$$V = \sqrt{P \cdot R}$$

Where

V = Continuous rated DC or AC (rms) working voltage (V)

P = Rated power (W)

R = Resistance value (Ω)

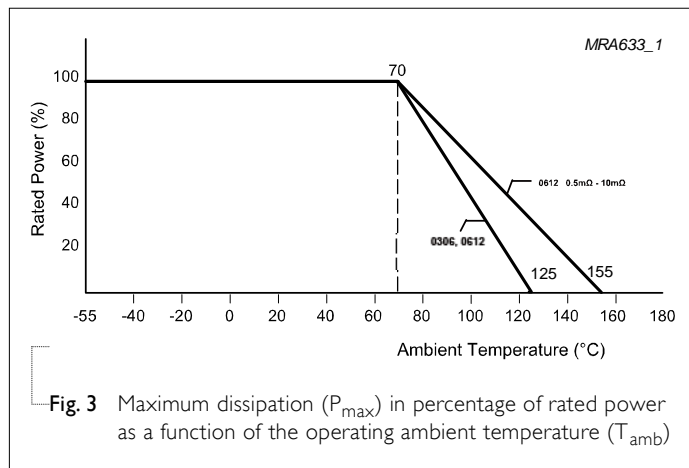

Fig. 3 Maximum dissipation (P_{max}) in percentage of rated power as a function of the operating ambient temperature (T_{amb})

PACKING STYLE AND PACKAGING QUANTITY

Table 3 Packing style and packaging quantity

PACKING STYLE	REEL DIMENSION	PS0306	PS0612
Paper taping reel (R)	7" (178 mm)	5,000	---
Embossed taping reel (K)	7" (178 mm)	---	4,000

PAPER TAPE

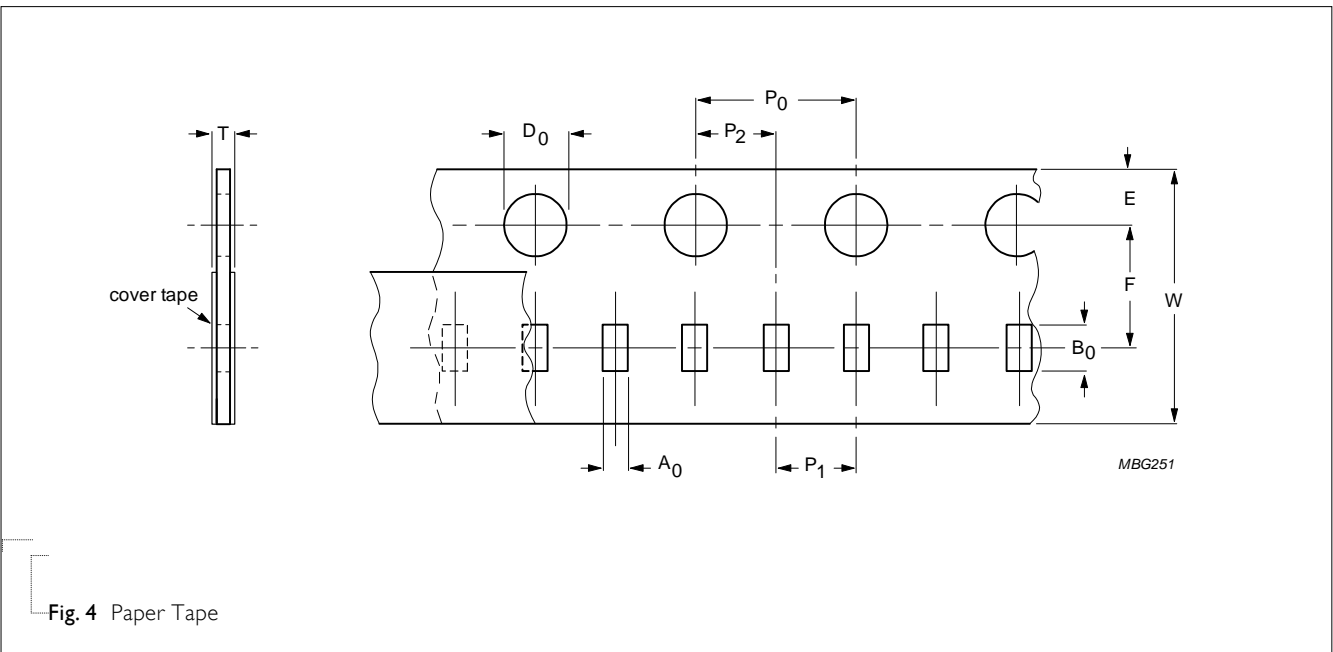

Fig. 4 Paper Tape

Table 4 Dimensions of paper tape for relevant chip resistors size

SIZE	SYMBOL										Unit: mm
	A ₀	B ₀	W	E	F	P ₀	P ₁	P ₂	ØD ₀	T	
PS0306	1.10±0.15	1.90±0.15	8.00±0.30	1.75±0.10	3.50±0.10	4.00±0.10	4.00±0.10	2.00±0.10	1.5±0.10	0.80±0.10	

EMBOSSED TAPE

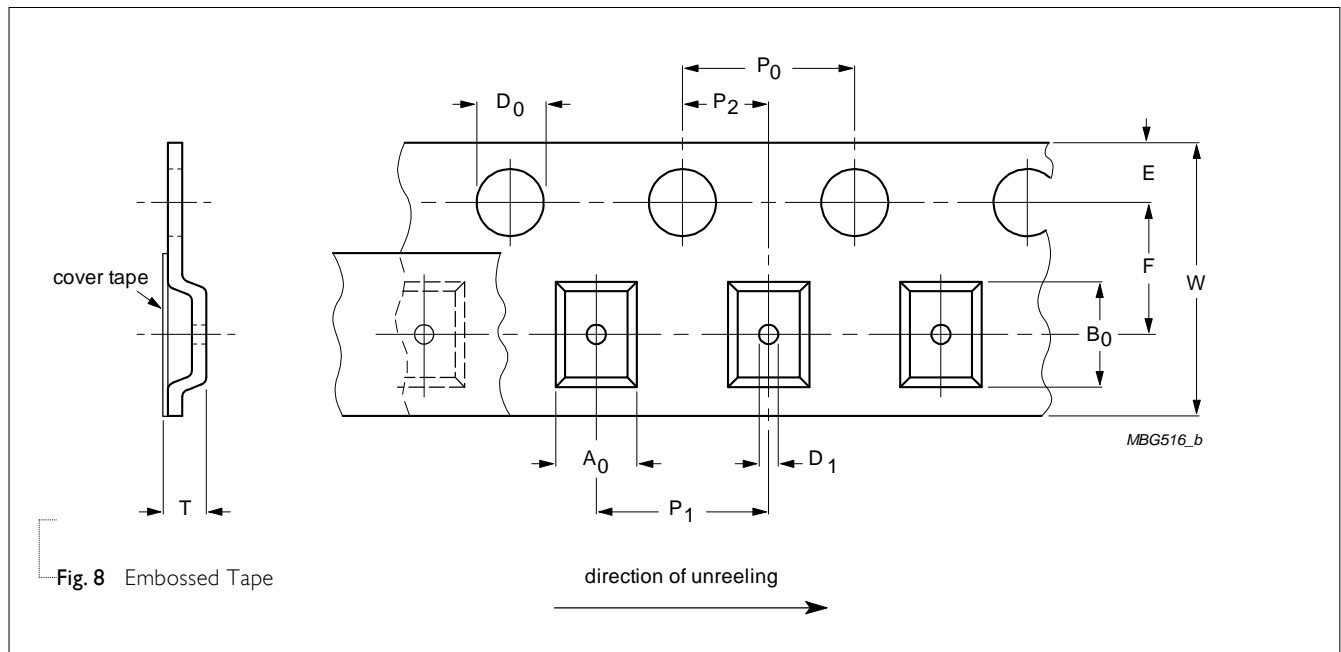

Fig. 8 Embossed Tape

Table 5 Dimensions of embossed tape for relevant chip resistors size

SIZE	SYMBOL										Unit: mm
	A ₀	B ₀	W	E	F	P ₀	P ₁	P ₂	ØD ₀	T	
PS0612	1.91±0.05	3.65±0.05	8.00+0.30/-0.10	1.75±0.10	3.50±0.05	4.00±0.10	4.00±0.10	2.00±0.05	1.5±0.10	0.88±0.05	

REEL SPECIFICATION

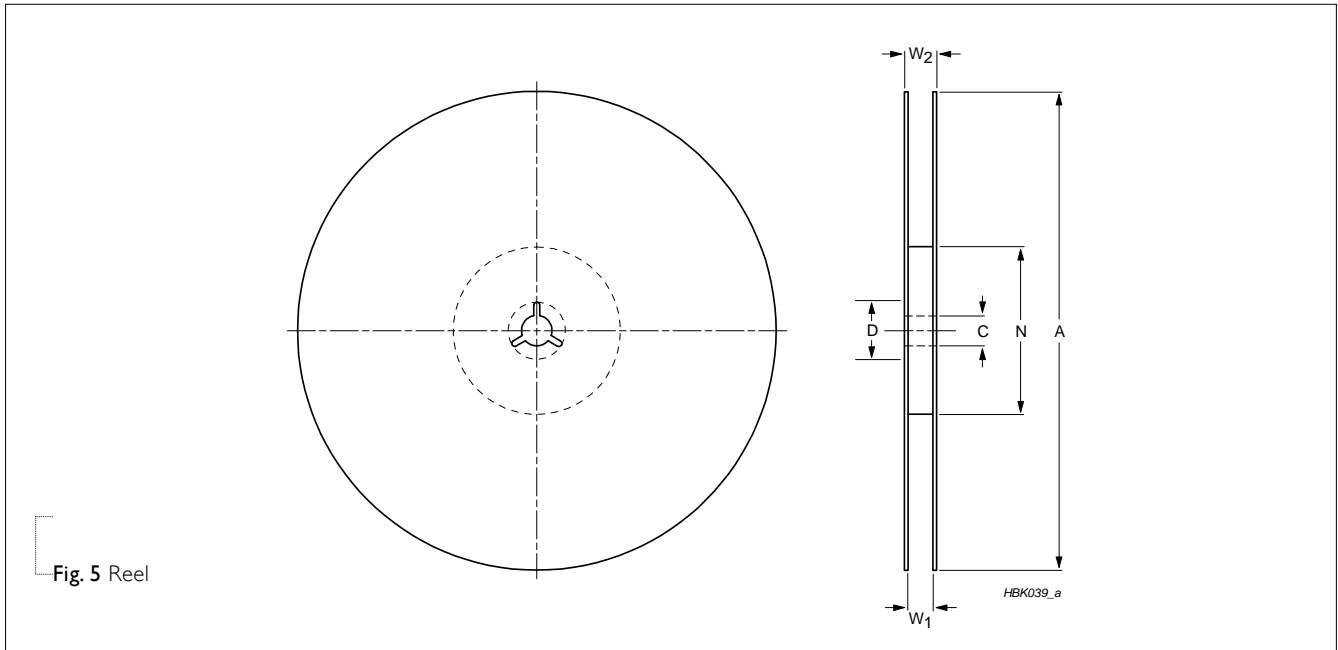

Table 6 Dimensions of reel specification for relevant chip resistors size

SIZE	QUANTITY PER REEL	REEL SIZE		SYMBOL			Unit: mm
		8 mm TAPE WIDE	7" (Ø 178 mm)	A	N	W_1	W_2 MAX.
PS0306	5000	7" (Ø 178 mm)	178.0±5	60.0±2	9.0±0.2	12.0±0.2	
PS0612	4000	7" (Ø 178 mm)	178.0± 5	60.0±2	9.0±0.2	12.0±0.2	

SOLDERING PROFILES

For recommended soldering profiles, please refer to data sheet “Chip resistors mounting”.

FOOTPRINT

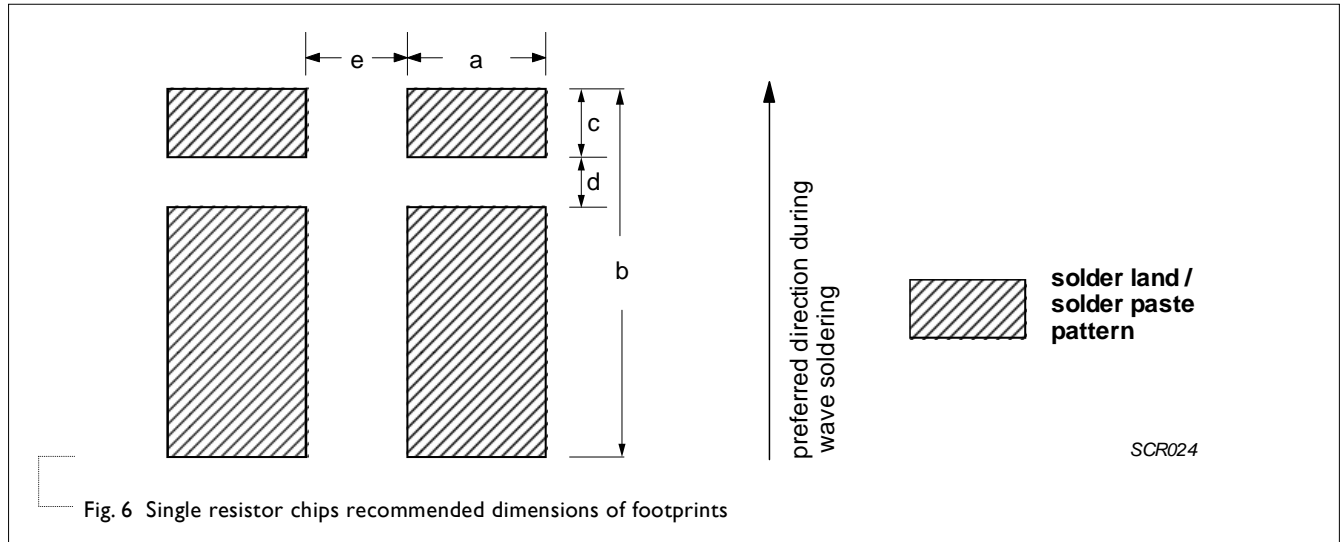

Fig. 6 Single resistor chips recommended dimensions of footprints

Table 7 Footprint dimensions

SIZE FOOTPRINT	DIMENSIONS CODE					Unit: mm
	a	b	c	d	e	t(um)
PS0306	0.40	1.75	0.35	0.20	0.20	105
PS0612	1.00	3.50	0.80	0.38	0.75	105

TESTS AND REQUIREMENTS
Table 8 Test condition, procedure and requirements

TEST	TEST METHOD	PROCEDURE	REQUIREMENTS
Life/ Operational Life/ Endurance	MIL-STD-202-method 108 IEC 60115-1 4.25.1	1,000 hours at 70±2 °C applied RCWV 1.5 hours on, 0.5 hour off, still air required	±(1%+0.0005 Ω)
High Temperature Exposure/ Endurance at Upper Category Temperature	IEC 60068-2-2	1,000 hours at 125 °C & 155 °C ,unpowered	±(1%+0.0005 Ω)
Moisture Resistance	MIL-STD-202-method 106	Each temperature / humidity cycle is defined at 8 hours (method 106F), 3 cycles / 24 hours for 10d with 25 °C / 65 °C 95% R.H, without steps 7a & 7b, unpowered Parts mounted on test-boards, without condensation on parts Measurement at 24±2 hours after test conclusion	±(0.5%+0.0005 Ω)
Thermal Shock	MIL-STD-202-method 107	-55/+125 °C Note: Number of cycles required is 300. Devices mounted Maximum transfer time is 20 seconds. Dwell time is 15 minutes. Air – Air	±(1%+0.0005 Ω)
Short Time Overload	IEC60115-1 4.13	5 times of rated power for 5 seconds at room temperature	±(1%+0.0005 Ω) No visible damage
Board Flex/ Bending	IEC 60068-2-21	Chips mounted on a 90mm glass epoxy resin PCB(FR4) 2 mm bending Bending time: 60±5 seconds	±(1%+0.0005 Ω) No visible damage

TEST	TEST METHOD	PROCEDURE	REQUIREMENTS
Solderability - Wetting	J-STD-002 test B	Electrical Test not required Magnification 50X SMD conditions: 1 st step: method B, aging 4 hours at 155 °C dry heat 2 nd step: leadfree solder bath at 245±3 °C Dipping time: 3±0.5 seconds	Well tinned (≥95% covered) No visible damage
- Resistance to Soldering Heat	IEC 60068-2-58	Condition B, no pre-heat of samples Leadfree solder, 260 °C, 10 seconds immersion time Procedure 2 for SMD: devices fluxed and cleaned with isopropanol	±(0.5%+0.0005 Ω) No visible damage

REVISION HISTORY

REVISION	DATE	CHANGE NOTIFICATION	DESCRIPTION
Version 1	July 16, 2019	-	- Extend resistor value
Version 0	Mar. 06, 2017	-	- New datasheet for current sensor - low TCR 4 terminal PS series

“Yageo reserves all the rights for revising the content of this datasheet without further notification, as long as the products itself are unchanged. Any product change will be announced by PCN.”