

Customer Information Sheet

IF IN DOUBT - ASK

©

NOT TO SCALE

THIRD ANGLE PROJECTION

ALL DIMENSIONS IN mm

EMBOSSED HARWIN LOGO
NO THROUGH CUT.

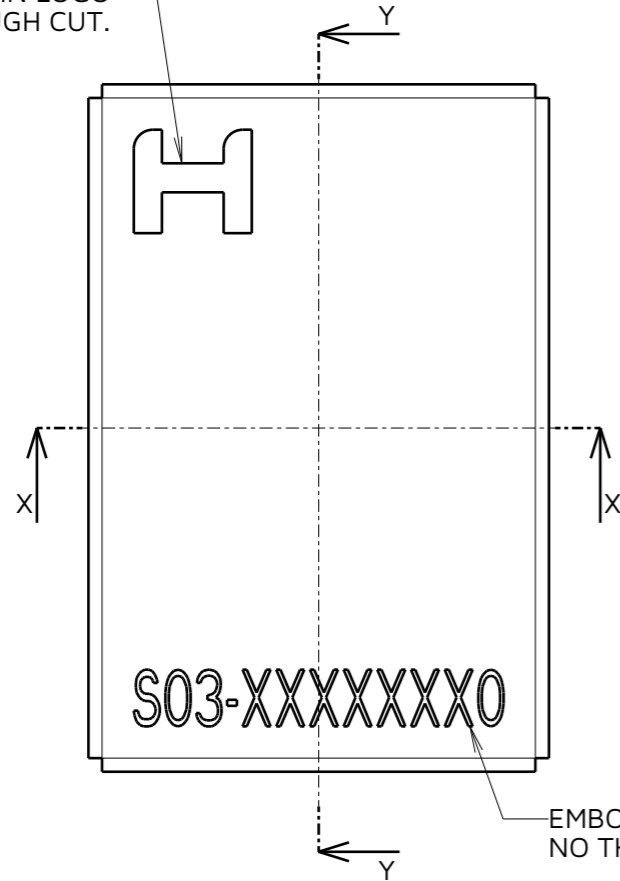

SECTION Y-Y

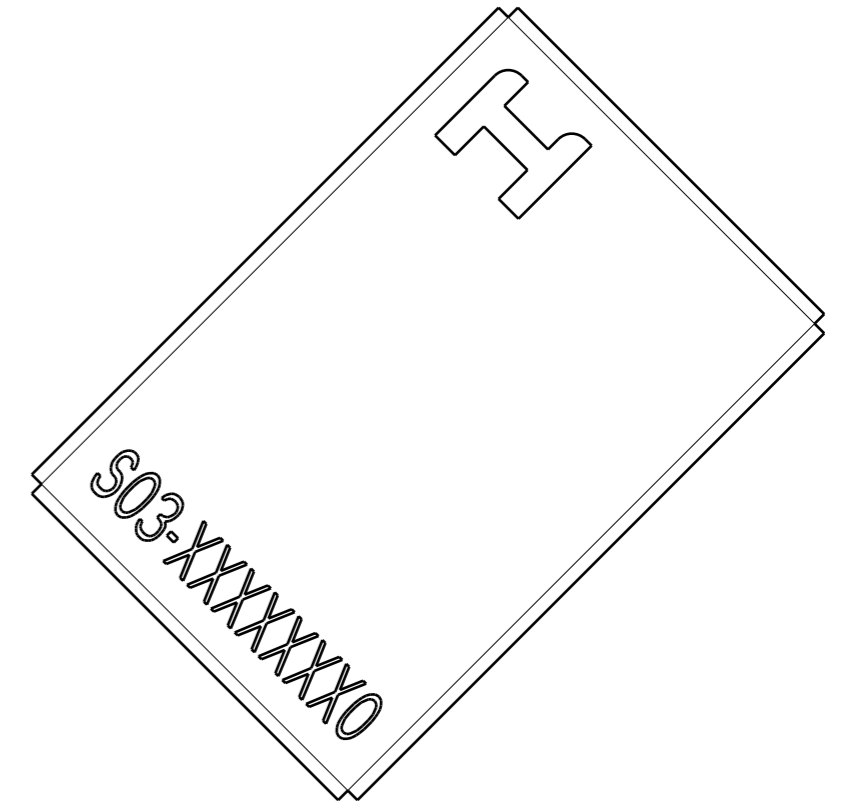
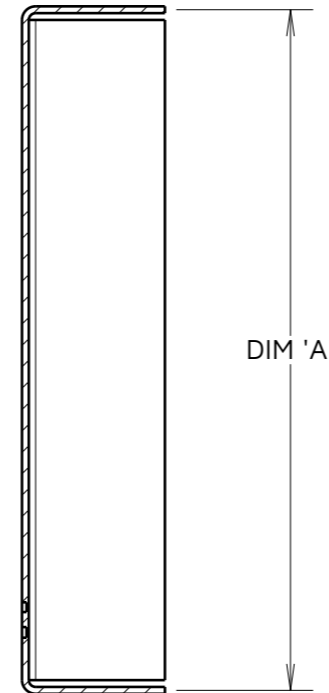

VIEW SHOWING CORNER OF THE SHIELD CAN

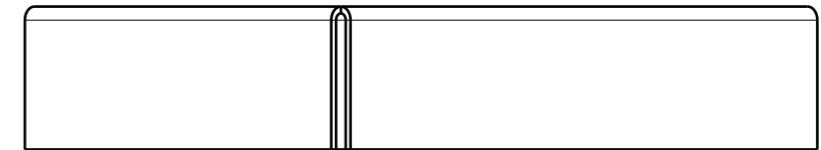

SECTION X-X

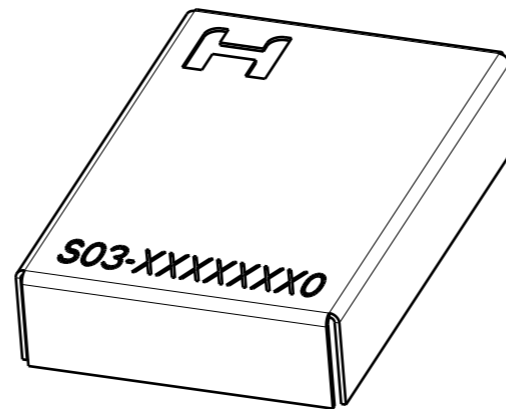
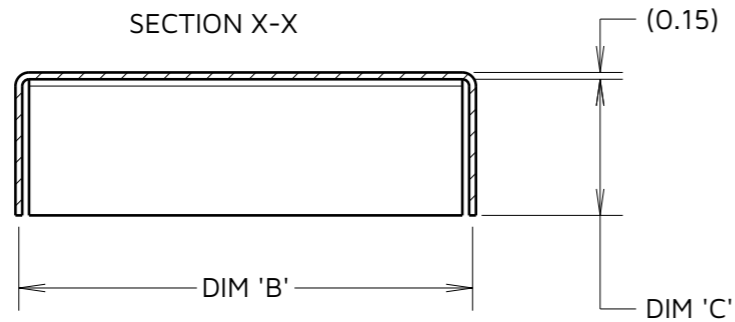

NOTES:

1. DIM 'C', HEIGHT OF THE CAN IS FROM THE BOTTOM EDGE TO THE INSIDE OF THE TOP FACE.
2. BOTH DIM 'A' AND 'B' ARE FROM THE CENTRE OF THE MATERIAL THICKNESS.
3. SHIELD CAN IS RECOMMENDED FOR USE WITH RFI SHIELD CLIPS: S0911-46R, S1001-46R, S0941-46R, S0961-46R AND S1721-46R.
4. SEE SHEET 4 FOR TAPE AND REEL DETAILS.

ORDER CODE:

S03-XXXXXXXXOR

SIZE:

DIM 'A' = LENGTH

DIM 'B' = WIDTH

DIM 'C' = HEIGHT

FINISH:

O = UNPLATED FINISH

PACKING:

R = TAPE AND REEL (SEE SHEET 2)

AB	5	30.04.24	33993
NAME	ISS.	DATE	CN/CO
APPROVED: A.BOXALL			
CHECKED: R.PORTLOCK			
DRAWN: M.RUDKIN			
ASSEMBLY DRG:			

PART No.	DIM 'A'	DIM 'B'	DIM 'C'
S03-10100300R	10.0	10.0	3.0
S03-15100300R	15.0	10.0	3.0
S03-30100300R	30.0	10.0	3.0

HARWIN

www.harwin.com

TOLERANCES
X. = ±1mm
X.X = ±0.50mm
X.XX = ±0.20mm
X.XXX = ±0.01mm
ANGLES = ±5°
UNLESS STATED

THIS DRAWING AND ANY INFORMATION OR DESCRIPTIVE MATTER SET OUT HEREON ARE CONFIDENTIAL AND COPYRIGHT PROPERTY OF THE HARWIN GROUP AND MUST NOT BE DISCLOSED, LOANED, COPIED OR USED FOR MANUFACTURING, TENDERING OR FOR ANY OTHER PURPOSE WITHOUT THEIR WRITTEN PERMISSION.

MATERIAL:
NICKEL SILVER, HALF
HARD NS106,
TO BS1653
0.15mm THICK

TITLE:
**EMC-BOARDWARE
SHIELD CAN**

DRAWING NUMBER:
S03-XXXXXXXXOR

SHT
3
OF
4

Customer Information Sheet

IF IN DOUBT - ASK

©

NOT TO SCALE

THIRD ANGLE PROJECTION

ALL DIMENSIONS IN mm

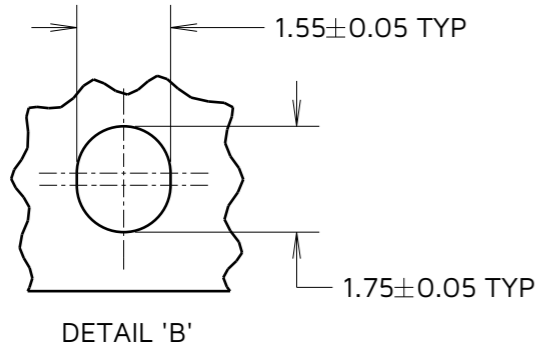
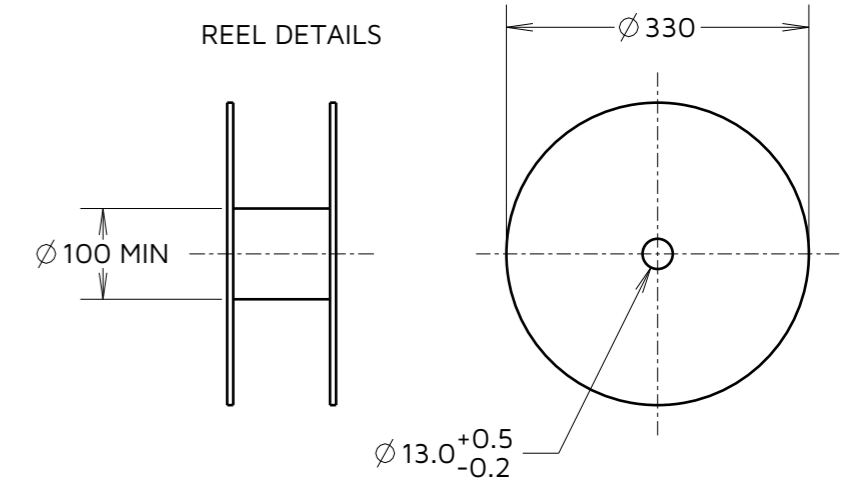
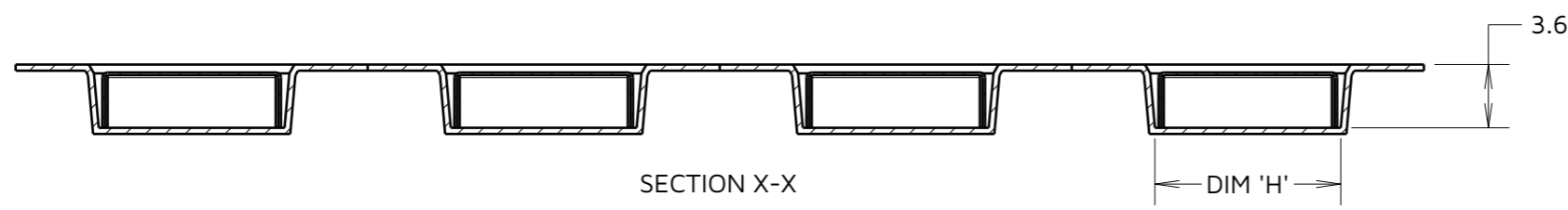
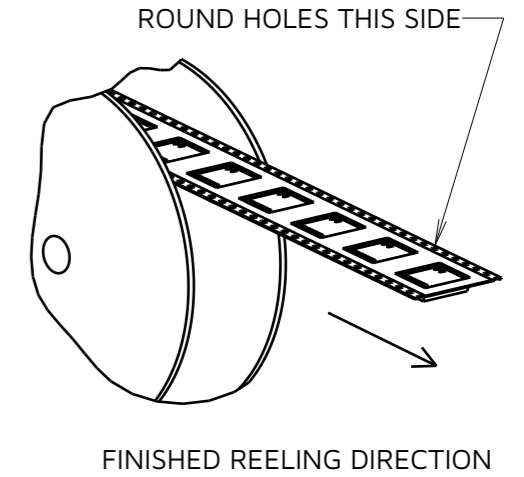
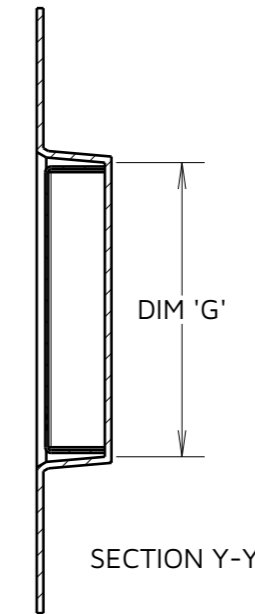
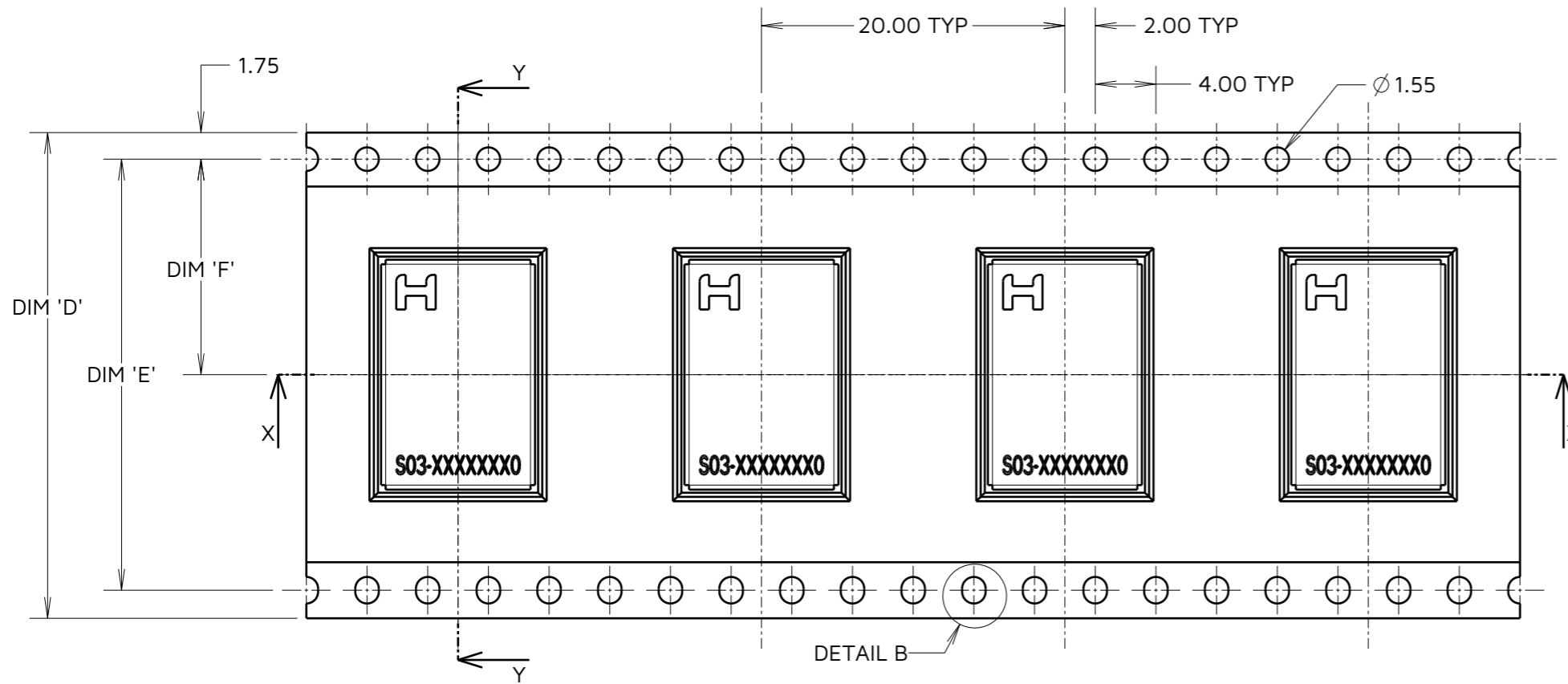

ORDER CODE:
S03-XXXXXXXOR

SIZE:
 DIM 'A' = LENGTH
 DIM 'B' = WIDTH
 DIM 'C' = HEIGHT

FINISH:
 O = UNPLATED FINISH

PACKING:
 R = TAPE AND REEL (SEE SHEET 2)

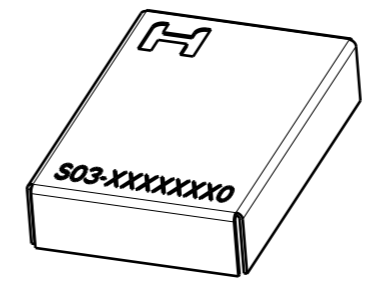

PART No.	DIM 'D'	DIM 'E'	DIM 'F'	DIM 'G'	DIM 'H'
S03-10100300R	32.00±0.30	28.40	14.20	10.55	10.55
S03-15100300R	32.00±0.30	28.40	14.20	15.55	10.55
S03-30100300R	44.00±0.30	40.40	20.20	30.55	10.55

AB	5	30.04.24	33993
NAME	ISS.	DATE	CN/CO
APPROVED: A.BOXALL			
CHECKED: R.PORTLOCK			
DRAWN: M.RUDKIN			
ASSEMBLY DRG:			

NOTES:
 5. QUANTITY OF COMPONENTS PER REEL = 900.
 6. PRODUCT IS TAPE AND REELED IN GENERAL ACCORDANCE WITH EIA-481-B (ELECTRONICS INDUSTRIES ASSOCIATION).



TOLERANCES
 X. = ±1mm
 X.X = ±0.50mm
 X.XX = ±0.20mm
 X.XXX = ±0.01mm
 ANGLES = ±5°
 UNLESS STATED

THIS DRAWING AND ANY INFORMATION OR DESCRIPTIVE MATTER SET OUT HEREON ARE CONFIDENTIAL AND COPYRIGHT PROPERTY OF THE HARWIN GROUP AND MUST NOT BE DISCLOSED, LOANED, COPIED OR USED FOR MANUFACTURING, TENDERING OR FOR ANY OTHER PURPOSE WITHOUT THEIR WRITTEN PERMISSION.

MATERIAL:
 SEE SHEET 3

TITLE:
EMC-BOARDWARE SHIELD CAN

DRAWING NUMBER:
S03-XXXXXXXOR