

Tri-Start TV-CTV

MIL-DTL-38999 Series III

EN3645 subminiature cylindrical connectors
High performance threaded cylindrical connectors





Amphenol



Connecting people + technology

www.amphenol-socapex.com

TABLE OF CONTENTS

TECHNICAL CHARACTERISTICS	6
• General characteristics	6
• Mechanical characteristics	7
• Environmental characteristics	8
• Electrical characteristics	9
• Insert arrangements	10
• Coding – Polarization	15
STANDARD RANGE	16
TV METALLIC SHELLS	16
• Aluminium shells presentation	16
• Bronze shells presentation	16
• Stainless steel shells presentation	16
• Overall dimensions	17
CTV COMPOSITE SHELLS	20
• Presentation	20
• Overall dimensions	20
PRINTED CIRCUIT BOARD CONNECTORS	22
• Panel drilling for composite and metallic receptacles	22
• Printed circuit board connectors	23
• Receptacles equipped with size 22D contacts	24
EXTENDED RANGE	40
REDUCED FLANGE 	40
STAND OFF RECEPTACLE	41
TVS-Y/TVS-YN HERMETIC RECEPTACLES	42
LANYARD RELEASE PLUGS	44
THRU-BULKHEAD RECEPTACLES	46
RECEPTACLES WITH ENHANCED SEALING	46
INTEGRATED BACKSHELLS	47
MIL-DTL-38999 SERIES III OPTICAL CONNECTORS	47
ACCESSORIES	48
PROTECTIVE CAPS	48
• Standard metallic caps	48
• Rubber caps 	49
BACKSHELLS	50
OTHER ACCESSORIES	51
• Dummy receptacles	51
• Holding support	51
• Plastic dust caps	51
• Crimp contacts	52
• Piggy back grommets	52
• Sealing plugs	53
• Dummy contacts	53
• Standard PC tail contacts	53
• Reducing ferrules	54
APPLICATION TOOLS	55
• Crimping tools	55
• Insertion and removal tools	55
HOW TO ORDER	56
• Standard versions	56
• Hermetic versions	58
• Lanyard released plugs	59
• Cross references	62

ABOUT US



ABOUT AMPHENOL SOCAPEX

Amphenol
Socapex

For over 65 years, **Amphenol Socapex** has been providing rugged and reliable connectors and interconnect solutions to a large base of customers worldwide in the military, aerospace and industrial markets.

Our products and solutions, designed for rugged and unique situations involving extreme conditions, provide the innovativeness and flexibility essential to meet the needs and requirements of these demanding sectors.

Headquartered in the Technic Valley between Geneva and Mont-Blanc, **Amphenol Socapex** has 30,000 m² of manufacturing capacity. Our in-house molding, machining, screw machining & assembly capabilities within our 2 facilities in France & India give us the ability to manage all types of volume with consistent quality.

More info on www.amphenol-socapex.com

Amphenol Socapex is part of Amphenol Group.



Thyez (74), France



Manufacturing site in Pune, India

ABOUT AMPHENOL

Amphenol

Founded in 1932, **Amphenol** is one of the largest manufacturers of interconnect products in the world. The company designs, manufactures, and markets electrical, electronic, and fiber optic connectors, interconnect systems, and coaxial and specialty cables.

Amphenol products are engineered and manufactured in the Americas, Europe, Asia and Africa and sold by a worldwide sales and marketing organization.

Amphenol has a diversified presence as a leader in high growth areas of the interconnect industry and provides solutions for customers in the automotive, broadband, industrial, information technology and data communications, military and aerospace, mobile devices, and mobile networks markets.

More info on www.amphenol.com

AMPHENOL SOCAPEX QUALITY & ENVIRONMENTAL CERTIFICATION

Quality certification :

ISO 9001 : 2000
Thyez (France) and Pune (India)



Military market quality certification (NATO) :

AQAP 2110
Thyez (France)



Aeronautical market quality certification :

EN9100 : 2003
Thyez (France) and Pune (India)



Environnemental certification :

ISO 14001 (2004)
Thyez (France)



CONNECTOR RANGE & ACCESSORIES

<p>STANDARD</p>	<p>TV METALLIC SHELLS</p> 	<p>CTV COMPOSITE SHELLS</p> 
<p>RANGE DERIVATED</p>	<p>REDUCED FLANGE</p> 	<p>STAND OFF RECEPTACLE</p> 
	<p>TVS-Y/TVS-YN HERMETIC</p> 	<p>BREAKAWAY CONNECTORS</p> 
	<p>THRU-BULKHEAD RECEPTACLES</p> 	<p>RECEPTACLES WITH ENHANCED SEALING</p> 
	<p>INTEGRATED BACKSHELLS</p> 	
<p>MIL-DTL-38999 OPTICAL CONNECTORS</p>	<p>TVOP</p> 	<p>STARTOP</p> 
<p>ACCESSORIES</p>	<p>BACKSHELLS</p> 	<p>PROTECTIVE CAPS</p> 

TECHNICAL CHARACTERISTICS GENERAL CHARACTERISTICS

TV-CTV CONNECTORS (MIL-DTL-38999 SERIES III/EN3645)

- MIL-DTL-38999 series III connectors
- EN3645 connectors
- Dedicated to harsh environment applications
- 9 shell sizes (from 09 to 25)
- Thread coupling
- 100% scoop-proof
- More than 80 contact arrangements
- Intermountable with MIL-DTL-38999 series I



AMPHENOL ADDED VALUE

Amphenol goes further the European and American standards by offering an extended range with:

- Inserts compatible with quadax
- Grounded connectors with conductive insert for specific use
- Receptacles with reinforced sealing
- Hermetic version in Y & N classes
- High density inserts (with size 23 contacts)
- Filtered versions using tubular or planar technology

MAIN FEATURES

SHELL MATERIAL AND PLATING:

- Aluminium Standard material
- Composite Lightweight solution up to 70%weight saving
Corrosion resistant up to 2000H of salt spray exposure
- Stainless steel Firewall capability
- Marine bronze High corrosion resistance
Robustness for marine applications

PLATING:

- Olive drab cadmium
- Nickel
- Passivation
- Black zinc nickel

CONTACTS

- Standard contacts plated with a minimum of 1.27µm gold
- Size 00, 4, 8, 10, 12, 16, 20, 22D, 23
- Signal, power, twinax, coax, quadax and optical termini

Contact protection: interfacial seal ensures sealing around each contact and prevents electrolytic erosion



OTHERS

Quick coupling

- Mate and self-lock in a 360° turn of the coupling nut
- Anti-decoupling device for high vibration performance

EMI/RFI protection:

- Shell to shell bottoming
- Grounding fingers on the plug shell

APPLICATIONS

Military and aeronautic applications:

battlefield, ground vehicles, aircrafts, communication systems...

Advanced industrial applications:

high vibration requirements, high density

TECHNICAL CHARACTERISTICS

MECHANICAL CHARACTERISTICS

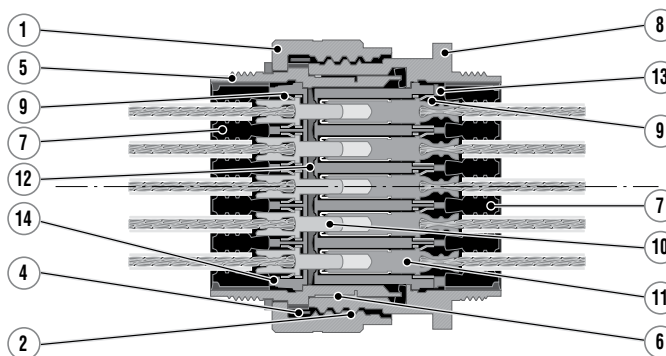
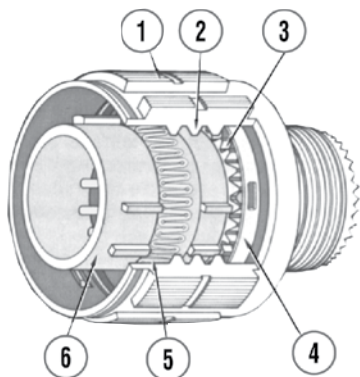

- | | |
|--------------------------|----------------------------|
| 1 Coupling nut | 8 Receptacle shell |
| 2 Quick coupling thread | 9 Contact retention clips |
| 3 Ratchet | 10 Crimping pin contact |
| 4 Anti decoupling device | 11 Crimping socket contact |
| 5 Plug shell | 12 Interfacial seal |
| 6 Spring fingers (EMI) | 13 Socket insert |
| 7 Grommet | 14 Pin insert |

- Thermoplastic insert
- Silicone rubber back insert and interfacial seal
- **Durability:** - 500 cycles
- 1500 cycles with composite connector " CTV " fitted with " H " and " J " contact types
- **Shocks:** half sine wave of 300 G magnitude during 3ms per EIA364.27
- **Sine vibrations:** - 60 g from - 55°C to + 175°C (olive drab cadmium finish)
- 60 g from - 55°C to +200°C (nickel finish and firewall version)
- **Random vibrations per EIA364.28:** - 1 G² / Hz at 175°C olive drab cadmium finish
- 1G² / Hz at 200°C nickel finish and firewall version
- 5G² / Hz at ambient
- **Bending moment**

Shell size		Bending moment Nm
MIL-DTL-38999 Series III	Amphenol	
A	09	11.3
B	11	33.9
C	13	45.2
D	15	56.5
E	17	67.8
F	19	79.1
G	21	90.4
H	23	101.7
J	25	113.0

• **Contact retention force**

Contact Size	23	22D	20	16	12	8	4
Maximum load (N)	44	44	67	111	111	111	150

TECHNICAL CHARACTERISTICS

ENVIRONMENTAL CHARACTERISTICS

• Salt spray exposure and working temperature:

• Waterproof shells

Shell material	Shell finish	Salt spray exposure per EIA364.26	Class norm	Amphenol	Operating temperature		Shell to shell Conductivity
					mini	maxi	
Composite	Electroless Nickel O.D cadmium	2000 H 2000 H	M J	CTV-RF CTV-RW	-65°C	+200°C*	3mΩ
					-65°C	+175°C	3mΩ
Aluminium	Electroless Nickel O.D cadmium Durmalon (Ni-PTFE) Green Zinc Cobalt Black Zinc Nickel	48 H 500 H 500H 96H 500H	F W T - Z	TVS-RF TV-RW TV-DT TV-RZ TV-ZN TV-DZ	-65°C	+200°C*	1mΩ
					-65°C	+175°C	2.5mΩ
					-65°C	+175°C	2.5mΩ
					-65°C	+175°C	3mΩ
					-65°C	+175°C	2.5mΩ
Stainless steel	Nickel —	500 H 500 H	S K	TVS-RS TVS-RK	-65°C	+200°C*	1mΩ
					-65°C	+200°C*	10mΩ
Bronze	—	500 H		TVS-RB	-65°C	+200°C*	5mΩ

• Hermetic shells

Shell materiel	Shell finish	Salt spray exposure per EIA364.26	Class norm	Amphenol	Operating temperature	
					min	max
Stainless steel	Nickel -	48 H 500 H	N Y	TVS-YN TVS-Y	-65°C	+200°C*
					-65°C	+200°C*

* 175°C maxi only for high-density contact arrangements

• **Humidity:** per MIL-DTL-38999: § 3.29

• **Altitude immersion:** according to MIL-DTL-38999 III standard (except hermetics)

• **Air leakage** < 1.10⁻⁷ cm³/s under 1 bar of differential pressure (hermetics only)

• Fluid immersion per EIA364.10:

- Hydraulic fluid, per MIL-H-5606
- Turbine fluid, grade JP-8, per MIL-DTL-83133 (NATO TYPE 34)
- Lubricating oil, per MIL-L-7808
- Lubricating oil, per MIL-PRF-23699
- Defrosting fluid, per MIL-A-8243
- Cleaning compound, diluted for cleaning, per MIL-PRF-87937 type I alkaline base
- Gasoline, per ASTM-D-4814
- Gasohol, per A-A-52530
- One part isopropyl alcohol, per TT-I-735, grade A or B ; and 3 parts mineral spirits, per A-A-2904, type II, grade A or P-D-680, type I, by volume
- Coolant, dielectric fluid, synthetic silicate ester base MIL-PRF-47220 (Coolanol 25) or equivalent
- Hydraulic fluid M2-V Chevron oil ST0145LB0001 or equivalent

TECHNICAL CHARACTERISTICS ELECTRICAL CHARACTERISTICS

• Contact rating - nominal current per contact

Contact size	23 *1	22 D	20	16	12	8	4	00
Crimp (A)	5	5	7.5	13	23	60	100	230
Hermetic (A)	3	3	5	10	17	-	-	-
PC Tail (A)	3	3	4.5	10	17	40	-	-
Resistance	15	8	4.7	2	1.1	0.6	0.26	-

• Contact resistance

Contact Size	23 *1	22D	20	16	12	8	4
Resistance (mΩ)	15	8	4.7	2	1.1	0.6	0.26

- Insulation resistance
 - at ambient > 5.10³ Mohms
 - at maximum temperature > 10³ Mohms

• Service rating

Service	Dielectric withstanding voltage (Vrms)								Working voltage	
	At sea level		15000 meters		21000 meters		34000 meters		Vrms	Vdc
	mated	unmated	mated	unmated	mated	unmated	mated	unmated		
M	1300	1300	800	550	800	350	800	200	400	550
I	1800	1800	1000	600	1000	400	1000	200	600	850
II	2300	2300	1000	800	1000	500	1000	200	900	1250

• Dimensions of acceptable contacts and cables

Contact Size	Contact Diameter mm	Crimp barrel		Acceptable cables						
		Diameter mm	Depth mm	Gauge AWG				Outside diameter (mm)		
				Section mm ²				Min	Average	Max
23 *1	0,68	0,88 ± 0,03	3,81	22	24	26	28	-	-	1.2
				0.38	0.22	0.15	0.095			
22D	0.76	0.88 ± 0.03	3.58	22	24	26	28	0.76	1.20	1.37
				0.38	0.22	0.15	0.095			
20	1	1.19 ± 0.03	5.30	20	22	24	-	1.02	1.83	2.11
				0.60	0.38	0.22	-			
16	1.57	1.70 ± 0.03	5.30	16	18	20	-	1.68	2.41	2.77
				1.34	0.93	0.60	-			
12	2.36	2.54 ± 0.06	10	12	14	-	-	2.46	3.20	3.61
				3.30	1.94	-	-			
8	3.60	4.6 ± 0.05	10	8				4.50	-	5.2
				8.98 Max acceptable: 10mm ²						
4	5.70	7.4 ± 0.05	12	4				7.73	-	8.4
				21.10						

*1 High-Density arrangements

TECHNICAL CHARACTERISTICS

INSERT ARRANGEMENTS

Contact Size	23 <i>(high density)</i>	22D	20	16	12	8	4
Caption							
Available:							
Coax	-	-	-	✓	✓	✓	-
Differential Twinax	-	-	-	-	-	✓	-
Quadax	-	-	-	-	-	✓	-
Power contacts	-	-	-	✓	✓	✓	✓
Grounded cavity	-	-	-	✓	✓	✓	-

Front face of male insert. (Only the major keyway is illustrated)

- 1 MIL-DTL-38999 Series III / EN3645 insert arrangement reference
- 2 TV-CTV insert arrangement
- 3 Service class
- 4 Number of contacts
- 5 Contact sizes

09

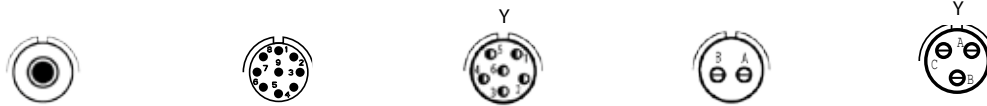

1	- / 09G01		A 35 / 09N35		A 98 / 09N98
2	09-05	09-09	09-35	09-94	09-98
3	N/A		M	M	I
4	1	9	6	2	3
5	8 Twinax°	23	22D	20	20

11



1	- / 11N01	B 2 / 11N02	- / 11N04	B 5 / 11N05	- / 11N12
2	11-01	11-02	11-04	11-05	11-12
3		I	I	I	II
4	1	2	4	5	1
5	8 Twinax°	16	20	20	12

11



1		B 35 / 11N35	B 98 / 11N98	B99 / 11N99
2	11-19	11-35	11-98	11-99
3		M	I	I
4	19	13	6	7
5	23	22D	20	20

13

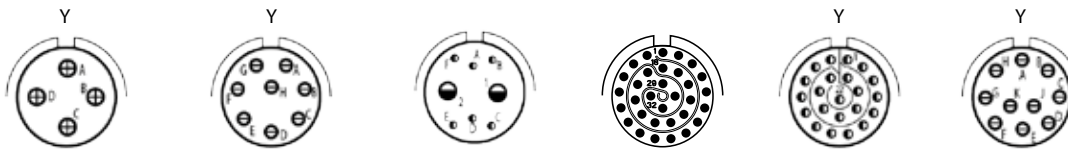

1	C 4 / 13N04	C 8 / 13N08	- / 13N26		C 35 / 13N35	C 98 / 13N98
2	13-04	13-08	13-26	13-32	13-35	13-98
3	I	I	M		M	I
4	4	8	6	2	32	10
5	16	20	22D	12	23	20

15

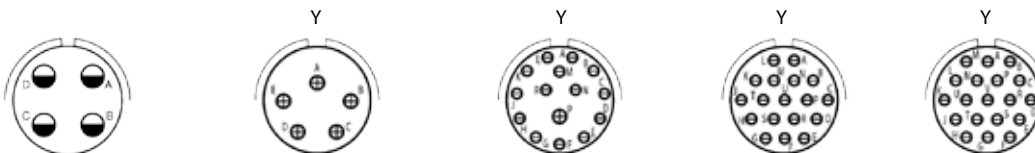

1		D 05 / 15N05	D 15 / 15N15	D 18 / 15N18	D 19 / 15N19
2	15-04	15-05	15-15	15-18	15-19
3	I	M	I	I	I
4	4	5	14	1	18
5	12	16	20	16	20

TECHNICAL CHARACTERISTICS

Contact Size	23 <small>(high density)</small>	22D	20	16	12	8	4
Caption	●	◐	◑	⊕	◑	●	○
Available:							
Coax	-	-	-	-	✓	✓	-
Differential Twinax	-	-	-	-	-	✓	-
Quadrax	-	-	-	-	-	✓	-
Power contacts	-	-	-	✓	✓	✓	✓
Grounded cavity	-	-	-	✓	✓	✓	-

INSERT ARRANGEMENTS

Front face of male insert. (Only the major keyway is illustrated)

- 1 MIL-DTL-38999 Series III / EN3645 insert arrangement reference
- 2 TV-CTV insert arrangement
- 3 Service class
- 4 Number of contacts
- 5 Contact sizes

15



1			D 35 / 15N35		D 97 / 15N97	
2	15-25**		15-35		15-55	
3	M		M		I	
4	22	3	37		8	4
5	22D	16	22D		20	16

17



1	E 2 / 17N02		E 6 / 17N06		E 8 / 17N08		- / 17N20		- / 17N22		E 26 / 17N26	
2	17-02		17-06		17-08		17-20**		17-22		17-26	
3	M		I		II		M		M		I	
4	38	1	6		8		16	4	2	2	26	
5	22D	8 Twinax°	12		16		22D	12	12 Coax	8 Twinax°	20	

17

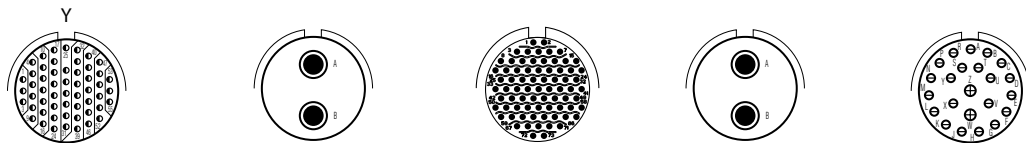

1	E 35 / 17N35						- / 17N75		E 99 / 17N99	
2	17-35		17-52		17-73		17-75		17-99	
3	M						M		I	
4	55		2		73		2		21	2
5	22D		8 Quadrax (meets 17-82 Boeing spec)		23		8 Twinax°		20	16

19



1	F 11 / 19N11		- / 19N17				F 18					
2	19-11		19-17				19-18		19-28		19-30	
3	II		M				M		I		I	
4	11	10	1	4	2	14	4	26	2	29	1	
5	16	22D	20	16	8 Twinax°	22D	8 Twinax°	20	16	20	16	

19



1	- / 19N31		F 32 / 19N32				F 35 / 19N35			
2	19-31		19-32				19-35		19-88	
3	M		I				M		I	
4	2	1	12		32		66		88	
5	8 Coax	12	22D		20		22D		23	

TECHNICAL CHARACTERISTICS

INSERT ARRANGEMENTS

Contact Size	23 <small>(high density)</small>	22D	20	16	12	8	4
Caption							
Available:							
Coax	-	-	-	✓	✓	✓	-
Differential Twinax	-	-	-	-	-	✓	-
Quadax	-	-	-	-	-	✓	-
Power contacts	-	-	-	✓	✓	✓	✓
Grounded cavity	-	-	-	✓	✓	✓	-

Front face of male insert. (Only the major keyway is illustrated)

- 1 MIL-DTL-38999 Series III / EN3645 insert arrangement reference
- 2 TV-CTV insert arrangement
- 3 Service class
- 4 Number of contacts
- 5 Contact sizes

21

1	G 11 / 21N11	G 16 / 21N16	- / 21N20	G 35 / 21N35	G 39 / 21N39
2	21-11	21-16	21-AJ	21-35	21-39
3	I	II	M	M	I
4	11	16	18	79	37 2
5	12	16	20	22D	20 16

21

1	G 41 / 21N41	21-48	G 75 / 21N75	21-121
2	21-41	21-48	21-75	21-121
3	I	M	M	
4	41	4	4	121
5	20	8 power	8 coax or 8 twinax*°	23

Quadax not available

23

1	- / 23N06	23-14	H 21 / 23N21	H 35 / 23N35
2	23-06	23-14	23-21	23-35
3	M	I	II	M
4	6	14	21	100
5	8 twinax*°	12	16	22D

23

1	H 53 / 23N53	- / 23N54	H 55 / 23N55	23-151
2	23-53	23-54	23-55	23-151
3	I	M	I	
4	53	40	55	151
5	20	22D	20	23

TECHNICAL CHARACTERISTICS

Contact Size	23 <small>(high density)</small>	22D	20	16	12	8	4
Caption	●	◐	⊖	⊕	◑	●	○
Available:							
Coax	-	-	-	✓	✓	✓	-
Differential Twinax	-	-	-	-	-	✓	-
Quadrax	-	-	-	-	-	✓	-
Power contacts	-	-	-	✓	✓	✓	✓
Grounded cavity	-	-	-	✓	✓	✓	-

INSERT ARRANGEMENTS

Front face of male insert. (Only the major keyway is illustrated)

- 1 MIL-DTL-38999 Series III / EN3645 insert arrangement reference
- 2 TV-CTV insert arrangement
- 3 Service class
- 4 Number of contacts
- 5 Contact sizes

25

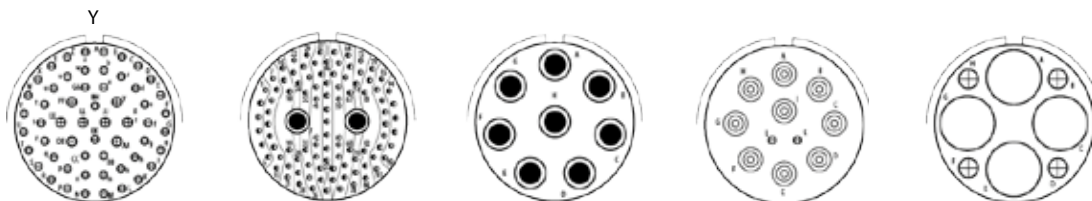

1	J 4 / 25N04		J 7 / 25N07		J 8 / 25N08		J 11 / 25N11		25-1A	
2	25-04		25-07		25-08		25-11		25-1A	
3	I		M		M		N		I	
4	48	8	97	2	8	2	9	4	4	
5	20	16	22D	8 Twinax°	8 twinax ⁴	20	10 power	16	4 power	

25

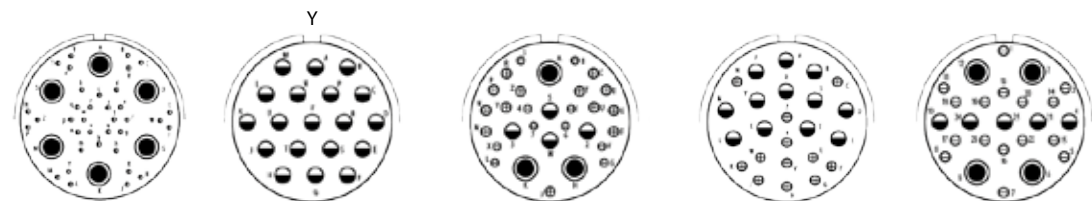

1	- / 25L17		J 19 / 25N19		J 20 / 25N20		J 24 / 25N24		- / 25N26			
2	25-17		25-19		25-20		25-24		25-26			
3	M		I		N		I		I			
4	36	6	19	10	13	3	4	12	12	16	5	4
5	22D	8 twinax°	12	20	16	8 twinax°	12 coax	16	12	20	12	8 coax

Quadrax not available

25

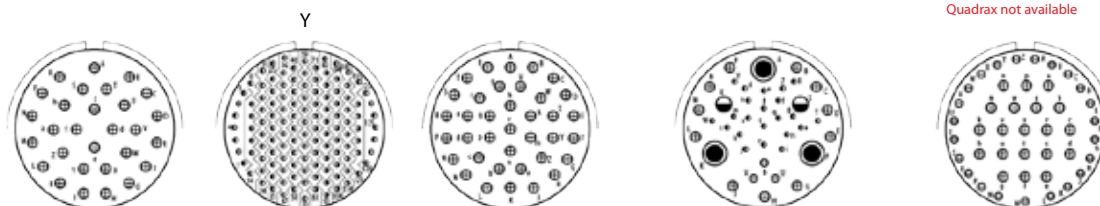

1	J 29 / 25N29		J 35 / 25N35		J 37 / 25N37		25-41		J 43 / 25N43	
2	25-29		25-35		25-37		25-41		25-43	
3	I		M		I		I		I	
4	29	128	37	22	3	11	2	3	23	20
5	16	22D	16	22D	20	16	12 coax	8 twinax°	20	16

Quadrax not available

25

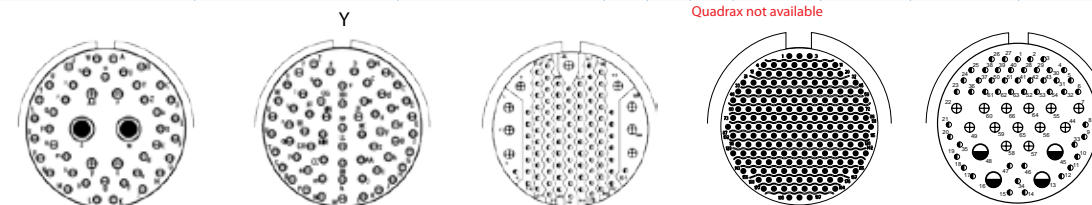

1	J 46 / 25N46		J 61 / 25N61		25-92**		25-187		25-F4	
2	25-46		25-61		25-92**		25-187		25-F4	
3	I		I		M		I		Size 22D=M, Balance =I	
4	40	4	2	61	92	9	187	49	13	4
5	20	16	8 coax	20	22D	16	23	22D	16	12

* Military P/N delivered with 8 twinax and proprietary P/N delivered with size 8 coaxial contacts for RG 180 and RG 195 wire.

** Not available in composite version.

Y Available in hermetic version.

○ Delivered with twinax contacts for simple braid cable (M17/1760002, AECMA Pr EN 3375 - 003, Raychem 10612, EPD44690, EPD44691).

Δ Delivered with twinax contacts for double braid cable (PAN 6421, AECMA Pr EN 3375 - 004, Raychem 10613, EPD44692, EPD44693).

TECHNICAL CHARACTERISTICS INSERT ARRANGEMENTS

Arrangements	Service Class	Total number of contacts	Number and size of contacts										Grounded insert availability**		Quadrax available		
			23	22D	20	16	12	12 coax	10 power	8 power	8 coax	8 triax or twinax	4 power	P		S	
			09-05*	N/A	1												
09-09		9	9														
09-35	M	6		6													
09-94	M	2			2												
09-98	I	3			3												
11-01		1											1				X
11-02	I	2				2									X	X	
11-04	I	4			4												
11-05	I	5			5												
11-12	II	1						1									
11-19		19	19														
11-35	M	13		13													
11-98	I	6			6												
11-99	I	7			7												
13-04	I	4				4									X		
13-08	I	8			8												
13-26	M	8		6				2									
13-32		32	32														
13-35	M	22		22													
13-98	I	10			10												
15-04	I	4						4									
15-05	II	5				5									X		
15-15	I	15			14	1											
15-18	I	18			18												
15-19	I	19			19												
15-25	M	25		22		3											
15-35	M	37		37													
15-55		55	55														
15-97	I	12			8	4											
17-02	M	39		38									1				X
17-06	I	6						6							X		
17-08	II	8				8									X	X	
17-20	M	20		16				4									
17-22		4							2				2		X	X	X
17-26	I	26			26												
17-35	M	55		55													
17-52	I	2													X	X	X
17-73		73	73														
17-75	M	2											2				X
17-99	I	23			21	2											
19-11	II	11				11									X	X	
19-17	M	17		10	1	4							2				X
19-18	M	18		14									4				X
19-28	I	28			26	2											
19-30	I	30			29	1											
19-31	M	15		12				1				2					X
19-32	I	32			32												
19-35	M	66		66													
19-88		88	88														
21-11	I	11						11									
21-16	II	16				16									X		
21-AJ	M	20			18								2				X
21-35	M	79		79													
21-39	I	39			37	2											
21-41	I	41			41												
21-48		4								4							
21-75°	M	4									4	or 4			X	X	X
21-121		121	121														

Legend: * High-Density arrangements
 * Only grounded insert version available
 ** Grounded version (metallic insert for use with coaxial, twinax or quadrax contacts, for receptacle only).
 ° 21-75 delivered with TWINAX contacts when ordered under the Mil P/N
 For CTV: 15-25& 17-20 arrangements not available

TECHNICAL CHARACTERISTICS INSERT ARRANGEMENTS

Arrangements	Service Class	Total number of contacts	Number and size of contacts											Grounded insert availability**		Quadrax available		
			23	22D	20	16	12	12 coax	10 power	8 power	8 coax	8 triax or twinax	4 power	P	S			
			23-06	M	6												6	
23-14	I	14						14										
23-21	II	21					21									X	X	
23-35	M	100		100														
23-53	I	53			53													
23-54	M	53		40		9	4											
23-55	I	55			55													
23-151		151	151															
25-04	I	56			48	8												
25-07	M	99		97									2					X
25-08	M	8											8		X	X		X
25-11	N	11			2				9									
25-1A		8				4								4				
25-17	M	42		36									6					X
25-19	I	19						19							X			
25-20	N	30			10	13		4*					3					X
25-24	I	24				12	12											
25-26	I	25			16		5						4					
25-29	I	29				29									X			
25-35	M	128		128														
25-37	I	37					37											
25-41	I	41		22	3	11		2*					3					
25-43	I	43			23	20												
25-46	I	46			40	4							2					X
25-61	I	61			61													
25-92	M	101		92		9												
25-187		187	187															
25-F4	M	66		49		13	4											

High-Density arrangements

Legend: ** Grounded version (metallic insert for use with coaxial, twinax or quadrax contacts, for receptacle only).

TECHNICAL CHARACTERISTICS CODING - POLARIZATION

To avoid cross-plugging problems in applications requiring the use of more than one MIL-DTL-38999 III connector of the same size, alternate key-rotations are available as indicated in the accompanying chart. As shown in the diagram below, the secondary keys rotate clockwise from the major one.

In the reference system, the polarization is shown by the letters N, A, B, C, D or E.

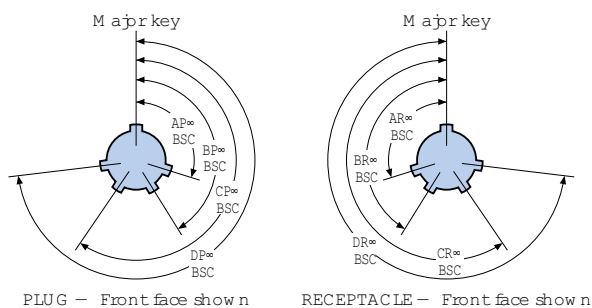

Shell size	Coding identification letter	AR° or AP° BSC	BR° or BP° BSC	CR° or CP° BSC	DR° or DP° BSC
9	N	105	140	215	265
	A	102	132	248	320
	B	80	118	230	312
	C	35	140	205	275
	D	64	155	234	304
11 and 13	E	91	131	197	240
	N	95	141	208	236
	A	113	156	182	292
	B	90	145	195	252
	C	53	156	220	255
15 and 17	D	119	146	176	298
	E	51	141	184	242
	N	80	142	196	293
	A	135	170	200	310
	B	49	169	200	244
19 and 21	C	66	140	200	257
	D	62	145	180	280
	E	79	153	197	272
	N	80	142	196	293
	A	135	170	200	310
23 and 25	B	49	169	200	244
	C	66	140	200	257
	D	62	145	180	280
	E	79	153	197	272
	N	80	142	196	293

STANDARD RANGE

TV METALLIC SHELLS



ALUMINIUM SHELLS

Presentation

Aluminium TV shell connectors are used in professional and international electronic defense programs in standard environmental conditions.

Main characteristics

- Material shell: Aluminium alloy.
- Shell to shell continuity: Max resistance - 1 mΩ for F class
- 2.5 mΩ for W-Z class
- Shell to contact continuity, for grounded inserts versions: Max resistance 10 mΩ
- EMI shielding effectiveness: - 1GHz: -85 dB (Class F, W-Z)
- 10 GHz: -65 dB (Class F); -50 dB (Class W-Z)
- Standard MIL wiring tools

MARINE BRONZE SHELLS

Presentation

TVS-B bronze connectors are not defined in MIL-DTL-38999-III standard but they are based on its requirements.

TVS-B connectors conform to the European standard CECC 75.201.002. (deviation F485 to be added for plug)

This series was initially selected by the British Navy for a new generation of ships. By extension a lot of the NATO Navy choose this series as a standard of interconnection.

Main characteristics

- Material shell: Nickel aluminum bronze DGS 1043.
- EMI shielding effectiveness: < -65 dB from 100 MHz to 10 GHz.

STAINLESS STEEL SHELLS

Presentation

Stainless steel shell connectors are used in high temperature environments and in harsh vibration conditions. They provide FIREWALL capabilities.

Main characteristics

- Thermosetting insert
- Shell to shell continuity: Max resistance - 10 mΩ for Class K
- 1 mΩ for Class S
- EMI shielding effectiveness: - 1 GHz: -65 dB (Class K); -85 dB (Class S)
- 10 GHz: -45 dB (ClassK); -65 dB (Class S)

STANDARD RANGE

TV METALLIC SHELLS

OVERALL DIMENSIONS / METALLIC VERSIONS

SQUARE FLANGE RECEPTACLE

- TVP00RW JD38999/20W
- TVP00ZN JD38999/20Z
- TVPS00RF JD38999/20F
- TVPS00RB JD38999/20K
- TVPS00RK JD38999/20K
- TVPS00RS JD38999/20S

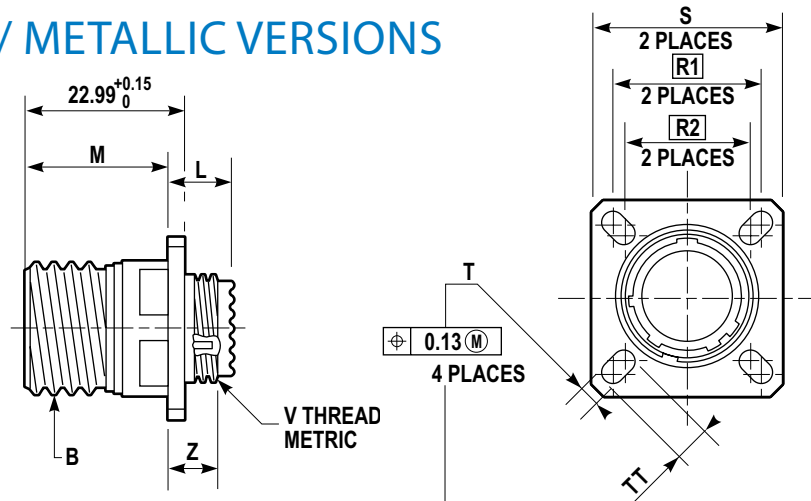

Shell size		B thread Class 2A 0.1P-0.3L-TS (inches)	L Max (mm)	M +0.00 -0.13 (mm)	R1 (mm)	R2 (mm)	S ±0.25 (mm)	T +0.20 -0.13 (mm)	Z1 Max (mm)	TT +0.20 -0.13 (mm)	V thread metric
MIL-DTL-38999 Series III	Amphenol										
A	9	.6250	11.91	20.83	18.26	15.09	23.83	3.25	3.89	5.49	M12x1-6g
B	11	.7500	11.91	20.83	20.62	18.26	26.19	3.25	3.89	4.93	M15x1-6g
C	13	.8750	11.91	20.83	23.01	20.62	28.58	3.25	3.89	4.93	M18x1-6g
D	15	1.0000	11.91	20.83	24.61	23.01	30.96	3.25	3.89	4.39	M22x1-6g
E	17	1.1875	11.91	20.83	26.97	24.61	33.32	3.25	3.89	4.93	M25x1-6g
F	19	1.2500	11.91	20.83	29.36	26.97	36.53	3.25	3.89	4.93	M28x1-6g
G	21	1.3750	12.70	20.07	31.75	29.36	39.67	3.25	4.65	4.93	M31x1-6g
H	23	1.5000	12.70	20.07	34.93	31.75	42.88	3.91	4.65	6.15	M34x1-6g
J	25	1.6250	12.70	20.07	38.10	34.93	46.02	3.91	4.65	6.15	M37x1-6g

For panel drilling, see section "Printed Circuit Board Connectors"

For PCB contacts stickout, see section "Printed Circuit Board Connectors"

Maximum panel thickness for rear panel mounting: 5mm from size 21 to 25
5,8mm from size 9 to 19

JAM NUT RECEPTACLE

- TV07RW JD38999/24W
- TV07ZN JD38999/24Z
- TVS07RF JD38999/24F
- TVS07RB JD38999/24K
- TVS07RK JD38999/24K
- TVS07RS JD38999/24S

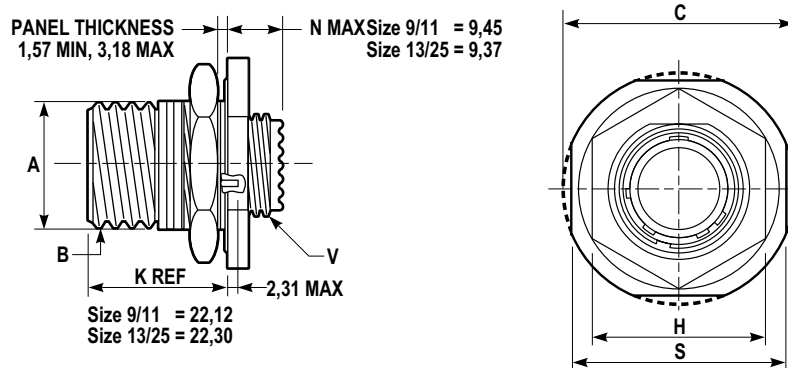

Shell size		B thread Class 2A 0.1P-0.3L-TS (inches)	A +0.10 -0.15 (mm)	C Max (mm)	H Hex +0.43 -0.41 (mm)	S +/-0.4 (mm)	V thread metric	Hex nut max torque N.m
MIL-DTL-38999 Series III	Amphenol							
A	9	.6250	16.53	30.45	22.23	26.97	M12x1-6g	4.1
B	11	.7500	19.07	35.20	25.40	31.75	M15x1-6g	5.3
C	13	.8750	23.82	38.38	30.17	34.93	M18x1-6g	6.9
D	15	1.0000	26.97	41.55	33.32	38.10	M22x1-6g	8.6
E	17	1.1875	30.15	44.73	36.52	41.28	M25x1-6g	9.8
F	19	1.2500	33.32	49.50	39.67	46.02	M28x1-6g	10.9
G	21	1.3750	36.50	52.65	42.87	49.23	M31x1-6g	12.7
H	23	1.5000	39.67	55.85	46.02	52.37	M34x1-6g	13.8
J	25	1.6250	42.85	59.00	50.80	55.58	M37x1-6g	15

For panel drilling, see section "Printed Circuit Board Connectors"

For PCB contacts stickout, see section "Printed Circuit Board Connectors"

STANDARD RANGE

TV METALLIC SHELLS

STRAIGHT PLUG

TV06RW	JD38999/26W
TV06ZN	JD38999/26Z
TVS06RF	JD38999/26F
TVS06RB	
TVS06RK	JD38999/26K
TVS06RS	JD38999/26S

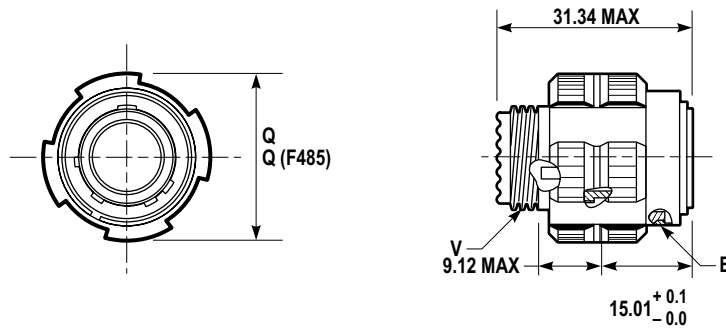

Shell size		B thread Class 2A 0.1P-0.3L-TS	Q Max (mm)	V thread metric (mm)	Q (F485)* (mm)
MIL-DTL-38999 Series III	Amphenol				
A	9	.6250	21.82	M12x1-6g	21.1
B	11	.7500	24.62	M15x1-6g	23.8
C	13	.8750	28.98	M18x1-6g	28.2
D	15	1.0000	32.16	M22x1-6g	31.4
E	17	1.1875	35.33	M25x1-6g	36.5
F	19	1.2500	38.10	M28x1-6g	39.3
G	21	1.3750	41.28	M31x1-6g	42.5
H	23	1.5000	44.45	M34x1-6g	45.3
J	25	1.6250	47.63	M37x1-6g	48.4

* Conforms to CECC 75.201.002 (coupling nut for arctic gloves)

NOTES

A series of horizontal dotted lines for taking notes.

STANDARD RANGE

CTV COMPOSITE SHELLS



PRESENTATION

Qualified to MIL- DTL- 38999 standard, the Amphenol composite Tri-Start Connectors offers a lightweight corrosion resistant connector with the same high performance features as its metal counterpart. It also includes the following features:

- Lightweight (20 - 40% weight savings vs. aluminium, 60 - 70% weight savings vs stainless steel)
- High Corrosion resistance
- Durability

Note: Coupling nuts and hexagonal nuts are delivered without plating (black)

MAIN CHARACTERISTICS

- Shell to shell continuity: Max resistance
 - Class M: 3 mΩ
 - Class J: 3 mΩ
- Durability: - 500 cycles with standards contacts
 - 1500 cycles with "H" type SAE AS39029 pin contacts and "J" type SAE AS39029 socket contacts
- Ozone exposure: MIL-DTL-38999 § 4.5.28 / EIA 364.14.
- Fungus resistance conforms to: MIL-STD-810, method 508.
- EMI shielding effectiveness:
 - 1 GHz: -85 dB (Class M, J)
 - 10 GHz: -65 dB (Class M), -50 dB (Class J)

OVERALL DIMENSIONS - COMPOSITE VERSIONS

SQUARE FLANGE RECEPTACLE

CTVP00RW JD38999/20J
CTVPS00RF JD38999/20M

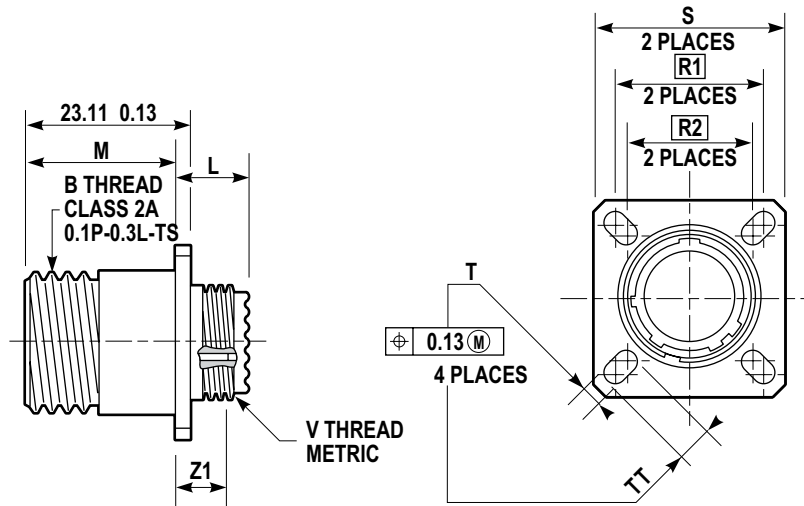

Shell size		B	L	M	R1	R2	S	T	Z1	TT	V thread
MIL-DTL-38999 Series III	Amphenol	Thread (inches)	Max (mm)	+0.00 -0.13 (mm)	(mm)	(mm)	±0.25 (mm)	+0.20 -0.13 (mm)	Max (mm)	+0.20 -0.13 (mm)	metric
A	9	.6250	13.055	19.685	18.26	15.09	23.83	3.25	5.03	5.49	M12x1-6g
B	11	.7500	13.055	19.685	20.62	18.26	26.19	3.25	5.03	4.93	M15x1-6g
C	13	.8750	13.055	19.685	23.01	20.62	28.58	3.25	5.03	4.93	M18x1-6g
D	15	1.0000	13.055	19.685	24.61	23.01	30.96	3.25	5.03	4.39	M22x1-6g
E	17	1.1875	13.055	19.685	26.97	24.61	33.32	3.25	5.03	4.93	M25x1-6g
F	19	1.2500	13.055	19.685	29.36	26.97	36.53	3.25	5.03	4.93	M28x1-6g
G	21	1.3750	13.843	18.923	31.75	29.36	39.67	3.25	5.79	4.93	M31x1-6g
H	23	1.5000	13.843	18.923	34.93	31.75	42.88	3.91	5.79	6.15	M34x1-6g
J	25	1.6250	13.843	18.923	38.10	34.93	46.02	3.91	5.79	6.15	M37x1-6g

For panel drilling, see section "Printed Circuit Board Connectors"

For PCB contacts stickout, see section "Printed Circuit Board Connectors"

Maximum panel thickness for rear panel mounting: 5,8mm from size 9 to 19
5mm from size 21 to 25

STANDARD RANGE CTV COMPOSITE SHELLS

JAM NUT RECEPTACLE

CTV07 RW JD38999/24J
CTVS07 RF JD38999/24M

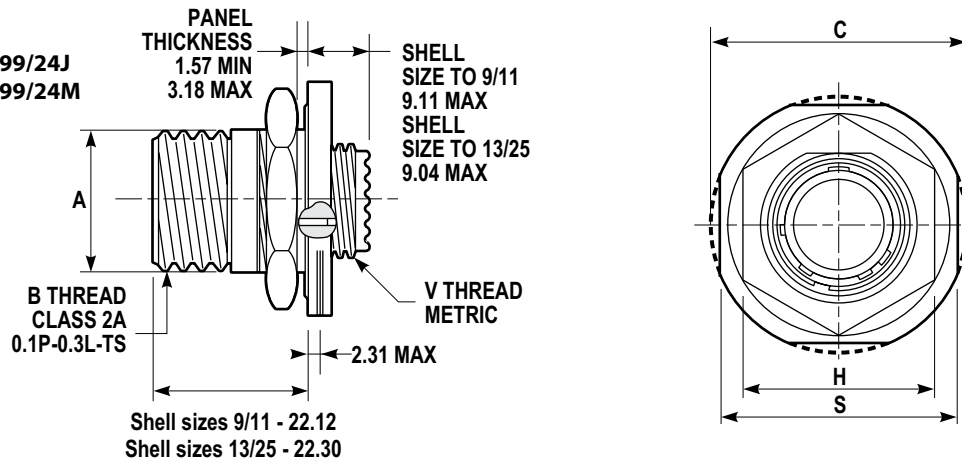

Shell size		A +0.00 -0.25 (mm)	B Thread (inches)	C Max (mm)	H Hex +0.43 -0.41 (mm)	S +0.28 -0.25 (mm)	V thread metric	Hex nut max torque N.m
MIL-DTL-38999 Series III	Amphenol							
A	9	16.99	.6250	30.45	22.23	26.97	M12x1-6g	4.1
B	11	19.53	.7500	35.20	25.40	31.75	M15x1-6g	5.3
C	13	24.26	.8750	38.38	30.17	34.92	M18x1-6g	6.9
D	15	27.53	1.0000	41.55	33.32	38.10	M22x1-6g	8.6
E	17	30.68	1.1875	44.73	36.52	41.28	M25x1-6g	9.8
F	19	33.86	1.2500	49.50	39.67	46.02	M28x1-6g	10.9
G	21	37.06	1.3750	52.65	42.87	49.22	M31x1-6g	12.7
H	23	40.00	1.5000	55.85	46.02	52.37	M34x1-6g	13.8
J	25	43.41	1.6250	59.00	50.80	55.57	M37x1-6g	15

For panel drilling, see section "Printed Circuit Board Connectors"
For PCB contacts stickout, see section "Printed Circuit Board Connectors"

STRAIGHT PLUG

CTV06 RW JD38999/26J
CTVS06 RF JD38999/26M

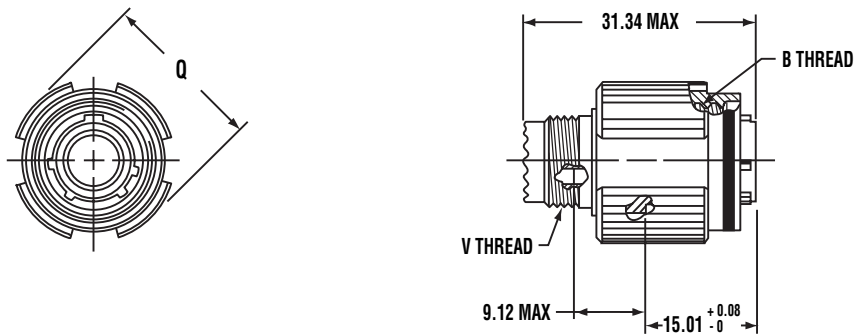

Shell size		B Thread 0.1P-0.3L-TS-2B (inches)	Q Max (mm)	V thread metric (mm)
MIL-DTL-38999 Series III	Amphenol			
A	9	.6250	21.82	M12x1-6g
B	11	.7500	24.99	M15x1-6g
C	13	.8750	29.39	M18x1-6g
D	15	1.0000	32.49	M22x1-6g
E	17	1.1875	35.69	M25x1-6g
F	19	1.2500	38.48	M28x1-6g
G	21	1.3750	41.68	M31x1-6g
H	23	1.5000	44.88	M34x1-6g
J	25	1.6250	47.98	M37x1-6g

STANDARD RANGE

PANEL DRILLING FOR COMPOSITE AND METALLIC RECEPTACLES

Square flange receptacle rear panel mounting

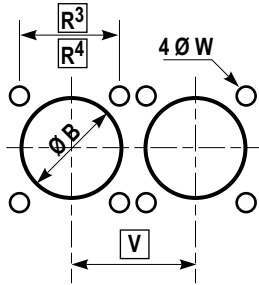

Square flange receptacle front panel mounting

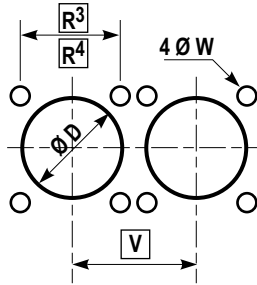

Jam nut receptacle rear panel mounting

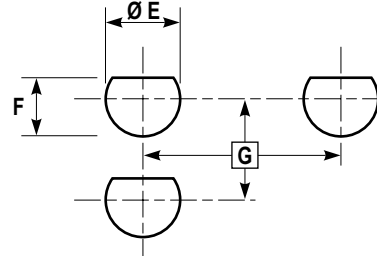

Shell size		R ³ (mm)	R ⁴ (mm)	V Mini (mm)	ØB Min (mm)	ØD Min (mm)	ØW +0 -0.25 (mm)	G Mini (mm)	ØE +0.25 0 (mm)	F +0 -0.25 (mm)
MIL-DTL-38999 Series III	Amphenol									
A	9	18.26	15.09	24.60	16.66	13.11	3.25	27.80	17.60	16.70
B	11	20.62	18.26	27.00	20.22	15.88	3.25	32.60	20.96	19.59
C	13	23.01	20.62	30.20	23.42	19.05	3.25	36.00	25.65	24.26
D	15	24.61	23.01	33.30	26.59	23.01	3.25	39.60	28.83	27.56
E	17	26.97	24.61	36.50	30.96	25.81	3.25	43.30	32.01	30.73
F	19	29.36	26.97	39.30	32.94	28.98	3.25	47.00	35.18	33.91
G	21	31.75	29.36	42.50	36.12	32.16	3.25	50.60	38.35	37.08
H	23	34.93	31.75	45.70	39.29	34.93	3.81	54.20	41.53	40.26
J	25	38.10	34.93	48.80	42.47	37.69	3.81	59.70	44.70	43.43

STANDARD RANGE

PRINTED CIRCUIT BOARD CONNECTORS

Contacts	Ø A (mm) Minimum hole diameter			
	CI Version		LI Version	
	Gold PCB contacts	Tinned PCB contacts	Gold PCB contacts	Tinned PCB contacts
Size 22D	0.8	0.9	1.0	1.1
Size 20	1.0	1.1	1.0	1.1

STANDARD PCB - TAIL DIMENSIONS AT THE REAR OF RECEPTACLES (IN MM)

			CI Contacts (5 mm tail length)						LI Contacts (8.5 mm tail length)					
			TV 07 - CTV 07		TVP 00		CTVP 00		TV 07 - CTV 07		TVP 00		CTVP 00	
			09 & 11	13 to 25	09 to 19	21 to 25	09 to 19	21 to 25	09 & 11	13 to 25	09 to 19	21 to 25	09 to 19	21 to 25
			Pin	L1	min	10.13	9.95	11.55	12.31	12.71	13.47	10.13	9.95	11.55
Max	11.07	10.89			12.39	13.15	13.52	14.28	11.07	10.89	12.39	13.15	13.52	14.28
L2	min	15.03		14.85	16.45	17.21	17.61	18.37	18.53	18.35	19.95	20.71	21.11	21.87
	Max	16.17		15.99	17.49	18.25	18.62	19.38	19.67	19.49	20.99	21.75	22.12	22.88
Socket	L1	min	9.93	9.75	11.35	12.11	12.51	13.27	9.93	9.75	11.35	12.11	12.51	13.27
		Max	10.87	10.69	12.19	12.95	13.32	14.08	10.87	10.69	12.19	12.95	13.32	14.08
	L2	min	14.83	14.65	16.25	17.01	17.41	18.17	18.33	18.15	19.75	20.51	20.91	21.67
		Max	15.97	15.79	17.29	18.05	18.42	19.18	19.47	19.29	20.79	21.55	21.92	22.68

For HD38999 inserts, the CI contacts dimensions are valid for pin contacts only. Consult us for socket contacts and pin contact LI version.

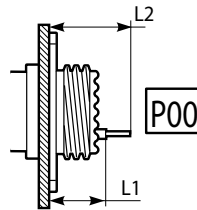
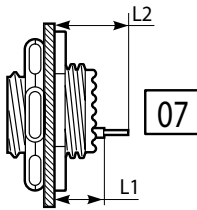

STANDARD RANGE

PRINTED CIRCUIT BOARD CONNECTORS

09

Cavity marking	X (mm)	Y (mm)
1	+1.14	+1.98
2	+1.98	-1.14
3	0	-2.29
4	-1.98	-1.14
5	-1.14	+1.98
6	0	0



Cavity marking	X (mm)	Y (mm)
1	0	+2.67
2	+1.89	+1.89
3	+2.67	0
4	+1.89	-1.89
5	0	-2.67
6	-1.89	-1.89
7	-2.67	0
8	-1.89	+1.89
9	0	0

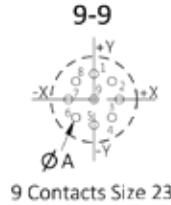

Cavity marking	X (mm)	Y (mm)
A	+1.65	+0.97
B	0	-1.91
C	-1.65	+0.97



11

Cavity marking	X (mm)	Y (mm)
A	0	0



Cavity marking	X (mm)	Y (mm)
A	+2.41	0
B	-2.41	0

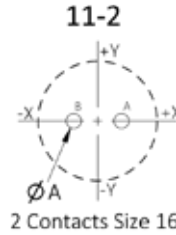

Cavity marking	X (mm)	Y (mm)
1	0	+4.08
2	+1.77	+3.06
3	+3.53	+2.04
4	+3.53	0
5	+3.53	-2.04
6	+1.77	-3.06
7	0	-4.08
8	-1.77	-3.06
9	-3.53	-2.04
10	-3.53	0
11	-3.53	+2.04
12	-1.77	+3.06
13	0	+2.04
14	+1.77	+1.02
15	+1.77	-1.02
16	0	-2.04
17	-1.77	-1.02
18	-1.77	+1.02
19	0	0



Cavity marking	X (mm)	Y (mm)
1	0	+3.71
2	+2.16	+3.00
3	+3.51	+1.14
4	+3.51	-1.14
5	+2.16	-3.00
6	0	-3.71
7	-2.16	-3.00
8	-3.51	-1.14
9	-3.51	+1.14
10	-2.16	+3.00
11	0	+1.42
12	+1.24	-0.89
13	-1.24	-0.89



Cavity marking	X (mm)	Y (mm)
A	+1.65	+1.65
B	+1.65	-1.65
C	-1.65	-1.65
D	-1.65	+1.65



Cavity marking	X (mm)	Y (mm)
A	+1.65	+1.42
B	+2.87	-1.65
C	0	-3.30
D	-2.87	-1.65
E	-1.65	+1.42



Cavity marking	X (mm)	Y (mm)
A	+1.91	+1.91
B	+1.91	-1.91
C	-1.91	-1.91
D	-1.91	+1.91



Cavity marking	X (mm)	Y (mm)
A	0	+3.30
B	+3.30	0
C	+1.65	-2.87
D	-1.65	-2.87
E	-3.30	0
F	0	0



Cavity marking	X (mm)	Y (mm)
A	+1.65	+2.87
B	+3.30	0
C	+1.65	-2.87
D	-1.65	-2.87
E	-3.30	0
F	-1.65	+2.87
G	0	0



STANDARD RANGE

PRINTED CIRCUIT BOARD CONNECTORS

13

Cavity marking	X (mm)	Y (mm)
A	0	+3.47
B	+2.47	+4.34
C	+2.47	-4.34
D	0	-3.47
E	-2.47	-4.34
F	-2.47	+4.34
1	+3.25	0
2	-3.25	0

13-26

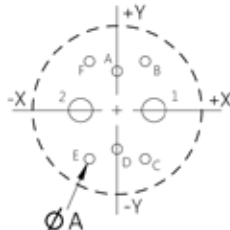

6 Contacts Size 22D
2 Contacts Size 12

Cavity marking	X (mm)	Y (mm)
1	0	+5.68
2	+2.05	+5.30
3	+3.83	+4.20
4	+5.09	+2.53
5	+5.66	+0.52
6	+5.46	-1.55
7	+4.53	-3.42
8	+2.99	-4.83
9	+1.04	-5.58
10	-1.04	-5.58
11	-2.99	-4.83
12	-4.53	-3.42
13	-5.46	-1.55
14	-5.66	+0.52
15	-5.09	+2.53
16	-3.83	+4.20

13-32

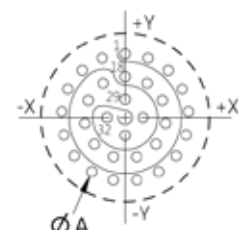

32 Contacts Size 23

Cavity marking	X (mm)	Y (mm)
17	-2.05	+5.30
18	0	+3.64
19	+1.97	+3.06
20	+3.31	+1.51
21	+3.60	-0.52
22	+2.75	-2.38
23	+1.03	-3.49
24	-1.03	-3.49
25	-2.75	-2.38
26	-3.60	-0.52
27	-3.31	+1.51
28	-1.97	+3.06
29	0	+1.60
30	+1.60	0
31	0	-1.60
32	-1.60	0

Cavity marking	X (mm)	Y (mm)
1	+1.14	+5.00
2	+3.20	+4.01
3	+4.62	+2.24
4	+5.16	0
5	+4.62	-2.24
6	+3.20	-4.01
7	+1.14	-5.00
8	-1.14	-5.00
9	-3.20	-4.01
10	-4.62	-2.24
11	-5.16	0
12	-4.62	+2.24
13	-3.20	+4.01
14	-1.14	+5.00
15	+1.14	+2.72
16	+2.97	+0.66
17	+2.36	-1.91
18	0	-3.05
19	-2.36	-1.91
20	-2.97	+0.66
21	-1.14	+2.72
22	0	-0.76

13-35

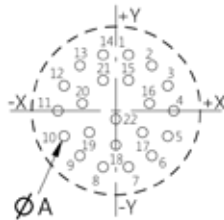

22 Contacts Size 22D

Cavity marking	X (mm)	Y (mm)
A	0	+3.81
B	+3.71	+0.89
C	0	-2.11
D	-3.71	+0.89

13-4

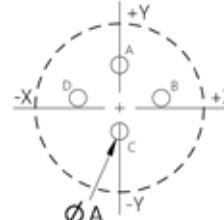

4 Contacts Size 16

Cavity marking	X (mm)	Y (mm)
A	+1.65	+3.99
B	+4.32	0
C	+3.05	-3.05
D	0	-4.32
E	-3.05	-3.05
F	-4.32	0
G	-1.65	+3.99
H	0	+1.12

13-8

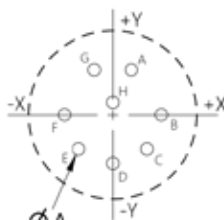

8 Contacts Size 20

Cavity marking	X (mm)	Y (mm)
A	0	+4.95
B	+3.18	+3.81
C	+4.90	+0.76
D	+4.17	-2.67
E	0	-3.43
F	-4.17	-2.67
G	-4.90	+0.76
H	-3.18	+3.81
J	+1.65	-0.38
K	-1.65	-0.38

13-98

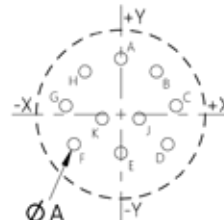

10 Contacts Size 20

STANDARD RANGE

PRINTED CIRCUIT BOARD CONNECTORS

15

Cavity marking	X (mm)	Y (mm)
A	+2.54	+5.72
B	+5.13	+3.56
C	+6.20	+0.36
D	+5.54	-2.87
E	+3.20	-5.31
F	0	-6.22
G	-3.20	-5.31
H	-5.54	-2.87
J	-6.20	+0.36
K	-5.13	+3.56
L	-2.54	+5.72
M	0	+3.56
N	+2.79	+1.02
P	0	-1.96
R	-2.79	+1.02

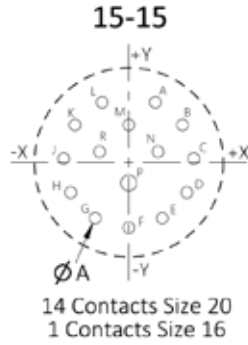

Cavity marking	X (mm)	Y (mm)
A	+1.65	+6.40
B	+4.95	+2.87
C	+6.60	0
D	+4.95	-2.87
E	+3.30	-5.72
F	0	-5.72
G	-3.30	-5.72
H	-4.95	-2.87
J	-6.60	0
K	-4.95	+2.87
L	-1.65	+6.40
M	-1.65	+2.87
N	+1.65	+2.87
P	+3.30	0
R	+1.65	-2.87
S	-1.65	-2.87
T	-3.30	0
U	0	0

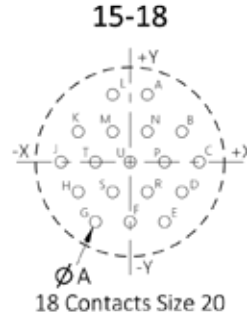

Cavity marking	X (mm)	Y (mm)
A	0	+5.72
B	+3.30	+5.72
C	+4.95	+2.87
D	+6.60	0
E	+4.95	-2.87
F	+3.30	-5.72
G	0	-5.72
H	-3.30	-5.72
J	-4.95	-2.87
K	-6.60	0
L	-4.95	+2.87
M	-3.30	+5.72
N	-1.65	+2.87
P	+1.65	+2.87
R	+3.30	0
S	+1.65	-2.87
T	-1.65	-2.87
U	-3.30	0
V	0	0

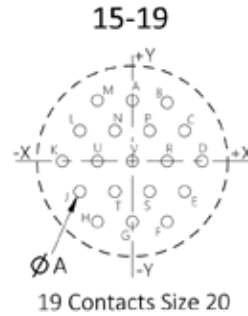

Cavity marking	X (mm)	Y (mm)
1	+1.14	+6.65
2	+3.12	+5.51
3	+5.36	+4.06
4	+6.45	+2.03
5	+6.76	-0.25
6	+6.27	-2.49
7	+5.08	-4.45
8	+3.30	-5.89
9	+1.14	-6.65
10	-1.14	-6.65
11	-3.30	-5.89
12	-5.08	-4.45
13	-6.27	-2.49
14	-6.76	-0.25
15	-6.45	+2.03
16	-5.36	+4.06
17	-3.12	+5.51
18	-1.14	+6.65
19	+1.14	+4.37

Cavity marking	X (mm)	Y (mm)
20	+3.12	+3.02
21	+4.32	+1.02
22	+4.32	-1.27
23	+3.12	-3.23
24	+1.14	-4.37
25	-1.14	-4.37
26	-3.12	-3.23
27	-4.32	-1.27
28	-4.32	+1.02
29	-3.12	+3.02
30	-1.14	+4.37
31	+1.14	+1.88
32	+2.29	-0.10
33	+1.14	-2.08
34	-1.14	-2.08
35	-2.29	-0.10
36	-1.14	+1.88
37	0	-0.10

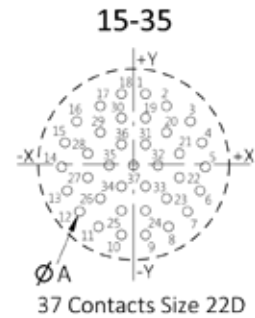

Cavity marking	X (mm)	Y (mm)
A	+3.18	+3.18
B	+3.18	-3.18
C	-3.18	-3.18
D	-3.18	+3.18

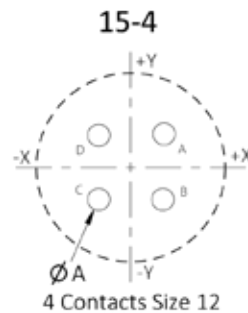

Cavity marking	X (mm)	Y (mm)
A	0	+2.54
B	+4.42	+0.61
C	+2.39	-3.76
D	-2.39	-3.76
E	-4.42	+0.61

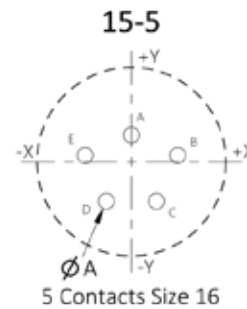

STANDARD RANGE

PRINTED CIRCUIT BOARD CONNECTORS

15

Cavity marking	X (mm)	Y (mm)
1	-2.04	+7.07
2	0	+7.07
3	+2.04	+7.07
4	-5.10	+5.30
5	-3.06	+5.30
6	-1.02	+5.30
7	+1.02	+5.30
8	+3.06	+5.30
9	+5.10	+5.30
10	-6.12	+3.53
11	-4.08	+3.53
12	-2.04	+3.53
13	0	+3.53
14	+2.04	+3.53
15	+4.08	+3.53
16	+6.12	+3.53
17	-7.14	+1.77
18	-5.10	+1.77
19	-3.06	+1.77

Cavity marking	X (mm)	Y (mm)
20	-1.02	+1.77
21	+1.02	+1.77
22	+3.06	+1.77
23	+5.10	+1.77
24	+7.14	+1.77
25	-6.12	0
26	-4.08	0
27	-2.04	0
28	0	0
29	+2.04	0
30	+4.08	0
31	+6.12	0
32	-7.14	-1.77
33	-5.10	-1.77
34	-3.06	-1.77
35	-1.02	-1.77
36	+1.02	-1.77
37	+3.06	-1.77
38	+5.10	-1.77

Cavity marking	X (mm)	Y (mm)
39	+7.14	-1.77
40	-6.12	-3.53
41	-4.08	-3.53
42	-2.04	-3.53
43	0	-3.53
44	+2.04	-3.53
45	+4.08	-3.53
46	+6.12	-3.53
47	-5.10	-5.30
48	-3.06	-5.30
49	-1.02	-5.30
50	+1.02	-5.30
51	+3.06	-5.30
52	+5.10	-5.30
53	-2.04	-7.07
54	0	-7.07
55	+2.04	-7.07

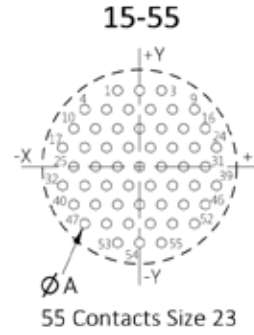

Cavity marking	X (mm)	Y (mm)
A	+1.65	+5.94
B	+4.52	+4.52
C	+5.84	-0.58
D	+4.52	-4.52
E	+1.65	-5.94
F	-2.26	-5.97
G	-5.26	-2.41
H	-5.94	+1.65
J	-4.52	+4.52
K	-1.65	+5.94
L	-1.19	+2.06
M	+1.19	-2.06

17

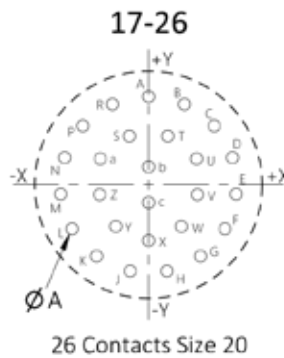

Cavity marking	X (mm)	Y (mm)
A	0	+8.15
B	+3.33	+7.44
C	+6.07	+5.44
D	+7.75	+2.51
E	+8.10	-0.86
F	+7.06	-4.09
G	+4.80	-6.60
H	+1.70	-7.98
J	-1.70	-7.98
K	-4.80	-6.60
L	-7.06	-4.09
M	-8.10	-0.86
N	-7.75	+2.51

Cavity marking	X (mm)	Y (mm)
P	-6.07	+5.44
R	-3.33	+7.44
S	-1.78	+4.50
T	+1.78	+4.50
U	+4.45	+2.39
V	+4.52	-0.91
W	+3.02	-3.84
X	0	-5.16
Y	-3.02	-3.84
a	-4.45	+2.39
b	0	+1.65
c	0	-1.65

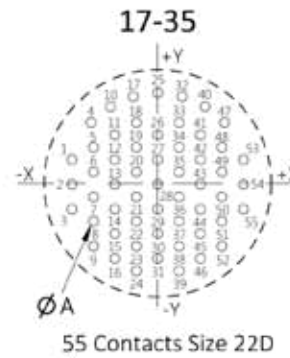

Cavity marking	X (mm)	Y (mm)
1	-7.92	+2.18
2	-7.92	-0.10
3	-7.92	-2.39
4	-6.15	+5.61
5	-5.94	+3.33
6	-5.94	+1.04
7	-5.94	-1.24
8	-5.94	-3.53
9	-5.94	-5.82
10	-4.37	+7.09
11	-3.96	+4.47
12	-3.96	+2.18
13	-3.96	-0.10
14	-3.96	-2.39
15	-3.96	-4.67
16	-3.96	-6.96
17	-2.26	+8.03
18	-1.98	+5.61
19	-1.98	+3.33

Cavity marking	X (mm)	Y (mm)
20	-1.98	+1.04
21	-1.98	-1.24
22	-1.98	-3.53
23	-1.98	-5.82
24	-1.98	-8.10
25	0	+8.36
26	0	+4.47
27	0	+2.18
28	0	-0.10
29	0	-2.39
30	0	-4.67
31	0	-6.96
32	+2.26	+8.03
33	+1.98	+5.61
34	+1.98	+3.33
35	+1.98	+1.04
36	+1.98	-1.24
37	+1.98	-3.53
38	+1.98	-5.82

Cavity marking	X (mm)	Y (mm)
39	+1.98	-8.10
40	+4.37	+7.09
41	+3.96	+4.47
42	+3.96	+2.18
43	+3.96	-0.10
44	+3.96	-2.39
45	+3.96	-4.67
46	+3.96	-6.96
47	+6.15	+5.61
48	+5.94	+3.33
49	+5.94	+1.04
50	+5.94	-1.24
51	+5.94	-3.53
52	+5.94	-5.82
53	+7.92	+2.18
54	+7.92	-0.10
55	+7.92	-2.39

STANDARD RANGE

PRINTED CIRCUIT BOARD CONNECTORS

17

Cavity marking	X (mm)	Y (mm)
A	+3.07	+5.31
B	+6.12	0
C	0	-6.12
D	-6.12	0
E	-3.07	+5.31
F	0	0

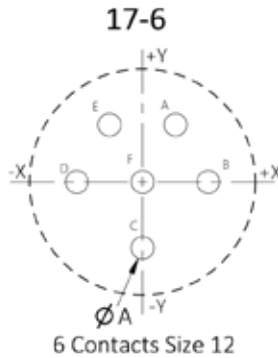

Cavity marking	X (mm)	Y (mm)
A	0	+5.99
B	+3.25	+2.18
C	+5.84	-1.98
D	+2.39	-5.49
E	-2.39	-5.49
F	-5.84	-1.98
G	-3.25	+2.18
H	0	-1.32

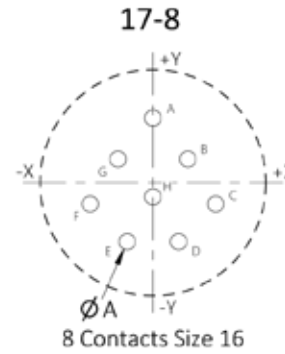

Cavity marking	X (mm)	Y (mm)
1	-1.02	+8.83
2	+1.02	+8.83
3	-4.08	+7.07
4	-2.04	+7.07
5	0	+7.07
6	+2.04	+7.07
7	+4.08	+7.07
8	-7.14	+5.30
9	-5.10	+5.30
10	-3.06	+5.30
11	-1.02	+5.30
12	+1.02	+5.30
13	+3.06	+5.30
14	+5.10	+5.30
15	+7.14	+5.30
16	-8.16	+3.53
17	-6.12	+3.53
18	-4.08	+3.53
19	-2.04	+3.53

Cavity marking	X (mm)	Y (mm)
20	0	+3.53
21	+2.04	+3.53
22	+4.08	+3.53
23	+6.12	+3.53
24	+8.16	+3.53
25	-7.14	+1.77
26	-5.10	+1.77
27	-3.06	+1.77
28	-1.02	+1.77
29	+1.02	+1.77
30	+3.06	+1.77
31	+5.10	+1.77
32	+7.14	+1.77
33	-8.16	0
34	-6.12	0
35	-4.08	0
36	-2.04	0
37	0	0
38	+2.04	0

Cavity marking	X (mm)	Y (mm)
39	+4.08	0
40	+6.12	0
41	+8.16	0
42	-7.14	-1.77
43	-5.10	-1.77
44	-3.06	-1.77
45	-1.02	-1.77
46	+1.02	-1.77
47	+3.06	-1.77
48	+5.10	-1.77
49	+7.14	-1.77
50	-8.16	-3.53
51	-6.12	-3.53
52	-4.08	-3.53
53	-2.04	-3.53
54	0	-3.53
55	+2.04	-3.53
56	+4.08	-3.53
57	+6.12	-3.53

Cavity marking	X (mm)	Y (mm)
58	+8.16	-3.53
59	-7.14	-5.30
60	-5.10	-5.30
61	-3.06	-5.30
62	-1.02	-5.30
63	+1.02	-5.30
64	+3.06	-5.30
65	+5.10	-5.30
66	+7.14	-5.30
67	-4.08	-7.07
68	-2.04	-7.07
69	0	-7.07
70	+2.04	-7.07
71	+4.08	-7.07
72	-1.02	-8.83
73	+1.02	-8.83

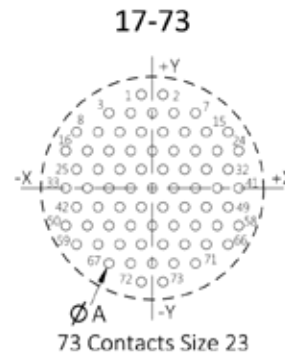

Cavity marking	X (mm)	Y (mm)
A	0	+8.15
B	+3.33	+7.44
C	+6.07	+5.44
D	+7.75	+2.51
E	+8.10	-0.86
F	+7.06	-4.09
G	+4.80	-6.60
H	+1.70	-7.98
J	-1.70	-7.98
K	-4.80	-6.60
L	-7.06	-4.09
M	-8.10	-0.86

Cavity marking	X (mm)	Y (mm)
N	-7.75	+2.51
P	-6.07	+5.44
R	-3.33	+7.44
S	-1.78	+4.50
T	+1.78	+4.50
U	+4.45	+2.39
V	+3.81	-1.91
W	0	-4.09
X	-3.81	-1.91
Y	-4.45	+2.39
Z	0	+0.64

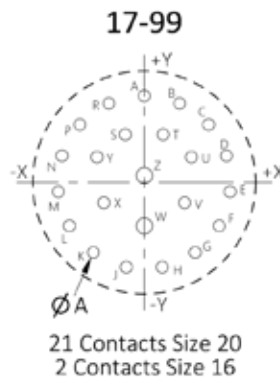

STANDARD RANGE

PRINTED CIRCUIT BOARD CONNECTORS

19

Cavity marking	X (mm)	Y (mm)
A	+2.67	+6.60
B	+6.35	+3.35
C	+6.99	-1.35
D	+4.55	-5.46
E	0	-7.14
F	-4.55	-5.46
G	-6.99	-1.35
H	-6.35	+3.35
J	-2.67	+6.60
K	0	+2.67
L	0	-2.34

19-11

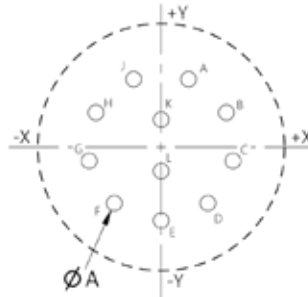

11 Contacts Size 16

Cavity marking	X (mm)	Y (mm)
A	+1.68	+8.97
B	+4.80	+7.75
C	+7.26	+5.51
D	+8.76	+2.49
E	+9.07	-0.84
F	+8.15	-4.06
G	+6.15	-6.73
H	+3.30	-8.51
J	0	-9.12
K	-3.30	-8.51
L	-6.15	-6.73
M	-8.15	-4.06
N	-9.07	-0.84
P	-8.76	+2.49
R	-7.26	+5.51
S	-4.80	+7.75

Cavity marking	X (mm)	Y (mm)
T	-1.68	+8.97
U	0	+5.84
V	+3.15	+4.90
W	+5.31	+2.41
X	+5.79	-0.84
Y	+4.42	-3.84
Z	+1.65	-5.61
a	-1.65	-5.61
b	-4.42	-3.84
c	-5.79	-0.84
d	-5.31	+2.41
e	-3.15	+4.90
f	0	+2.44
g	+2.44	0
h	0	-2.44
j	-2.44	0

19-32

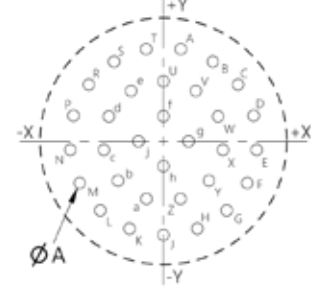

32 Contacts Size 20

Cavity marking	X (mm)	Y (mm)
1	-9.07	+2.29
2	-9.07	0
3	-9.07	-2.29
4	-7.09	+5.72
5	-7.09	+3.43
6	-7.09	+1.14
7	-7.09	-1.14
8	-7.09	-3.43
9	-7.09	-5.72
10	-5.11	+6.86
11	-5.11	+4.57
12	-5.11	+2.29
13	-5.11	0
14	-5.11	-2.29
15	-5.11	-4.57
16	-5.11	-6.86
17	-3.12	+8.00
18	-3.12	+5.72
19	-3.12	+3.43
20	-3.12	+1.14
21	-3.12	-1.14
22	-3.12	-3.43

Cavity marking	X (mm)	Y (mm)
23	-3.12	-5.72
24	-3.12	-8.00
25	-1.14	+9.14
26	-1.14	+6.86
27	-1.14	+4.57
28	-1.14	+2.29
29	-1.14	0
30	-1.14	-2.29
31	-1.14	-4.57
32	-1.14	-6.86
33	-1.14	-9.14
34	+1.14	+9.14
35	+1.14	+6.86
36	+1.14	+4.57
37	+1.14	+2.29
38	+1.14	0
39	+1.14	-2.29
40	+1.14	-4.57
41	+1.14	-6.86
42	+1.14	-9.14
43	+3.12	+8.00
44	+3.12	+5.72

Cavity marking	X (mm)	Y (mm)
45	+3.12	+3.43
46	+3.12	+1.14
47	+3.12	-1.14
48	+3.12	-3.43
49	+3.12	-5.72
50	+3.12	-8.00
51	+5.11	+6.86
52	+5.11	+4.57
53	+5.11	+2.29
54	+5.11	0
55	+5.11	-2.29
56	+5.11	-4.57
57	+5.11	-6.86
58	+7.09	+5.72
59	+7.09	+3.43
60	+7.09	+1.14
61	+7.09	-1.14
62	+7.09	-3.43
63	+7.09	-5.72
64	+9.07	+2.29
65	+9.07	0
66	+9.07	-2.29

19-35

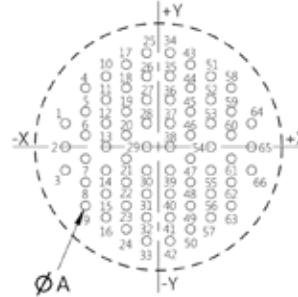

66 Contacts Size 22D

Cavity marking	X (mm)	Y (mm)
1	0	+9.99
2	+2.08	+9.77
3	+4.06	+9.12
4	+5.87	+8.08
5	+7.42	+6.68
6	+8.65	+4.99
7	+9.50	+3.09
8	+9.93	+1.04
9	+9.93	-1.04
10	+9.50	-3.09
11	+8.65	-4.99
12	+7.42	-6.68
13	+5.87	-8.08
14	+4.06	-9.12
15	+2.08	-9.77
16	0	-9.99
17	-2.08	-9.77
18	-4.06	-9.12
19	-5.87	-8.08
20	-7.42	-6.68
21	-8.65	-4.99
22	-9.50	-3.09

Cavity marking	X (mm)	Y (mm)
23	-9.93	-1.04
24	-9.93	+1.04
25	-9.50	+3.09
26	-8.65	+4.99
27	-7.42	+6.68
28	-5.87	+8.08
29	-4.06	+9.12
30	-2.08	+9.77
31	0	+7.95
32	+2.06	+7.67
33	+3.97	+6.88
34	+5.62	+5.62
35	+6.88	+3.97
36	+7.67	+2.06
37	+7.95	0
38	+7.67	-2.06
39	+6.88	-3.97
40	+5.62	-5.62
41	+3.97	-6.88
42	+2.06	-7.67
43	0	-7.95
44	-2.06	-7.67

Cavity marking	X (mm)	Y (mm)
45	-3.97	-6.88
46	-5.62	-5.62
47	-6.88	-3.97
48	-7.67	-2.06
49	-7.95	0
50	-7.67	+2.06
51	-6.88	+3.97
52	-5.62	+5.62
53	-3.97	+6.88
54	-2.06	+7.67
55	0	+5.91
56	+2.02	+5.55
57	+3.80	+4.52
58	+5.11	+2.95
59	+5.82	+1.03
60	+5.82	-1.03
61	+5.11	-2.95
62	+3.80	-4.52
63	+2.02	-5.55
64	0	-5.91
65	-2.02	-5.55
66	-3.80	-4.52

19-88

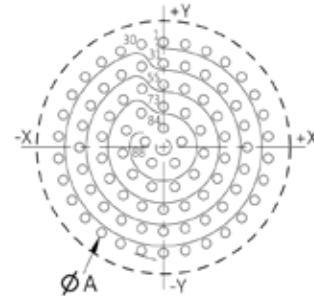

88 Contacts Size 23

Cavity marking	X (mm)	Y (mm)
67	-5.11	-2.95
68	-5.82	-1.03
69	-5.82	+1.03
70	-5.11	+2.95
71	-3.80	+4.52
72	-2.02	+5.55
73	0	+3.87
74	+2.09	+3.25
75	+3.52	+1.61
76	+3.83	-0.55
77	+2.92	-2.53
78	+1.09	-3.71
79	-1.09	-3.71
80	-2.92	-2.53
81	-3.83	-0.55
82	-3.52	+1.61
83	-2.09	+3.25
84	0	+1.83
85	+1.74	+0.56
86	+1.09	-1.48
87	-1.09	-1.48
88	-1.74	+0.56

STANDARD RANGE

PRINTED CIRCUIT BOARD CONNECTORS

21

Cavity marking	X (mm)	Y (mm)
A	+3.07	+8.43
B	+7.77	+4.50
C	+8.84	-1.55
D	+5.77	-6.86
E	0	-8.97
F	-5.77	-6.86
G	-8.84	-1.55
H	-7.77	+4.50
J	-3.07	+8.43
K	0	+3.12
L	0	-2.92

21-11

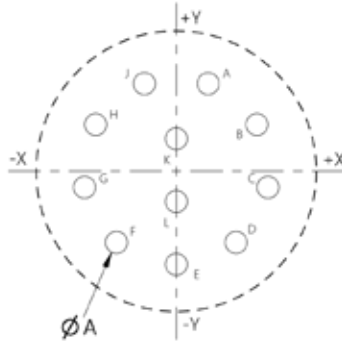

11 Contacts Size 12

Cavity marking	X (mm)	Y (mm)
A	+3.00	+8.18
B	+6.88	+5.36
C	+8.66	+0.91
D	+7.82	-3.81
E	+4.62	-7.37
F	0	-8.71
G	-4.62	-7.37
H	-7.82	-3.81
J	-8.66	+0.91
K	-6.88	+5.36
L	-3.00	+8.18
M	0	+4.45
N	+3.91	+1.57
P	+2.39	-3.10
R	-2.39	-3.10
S	-3.91	+1.57

21-16

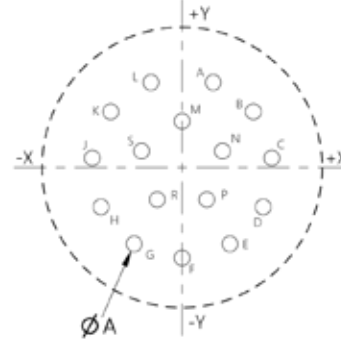

16 Contacts Size 16

Cavity marking	X (mm)	Y (mm)
1	+1.70	+10.46
2	+4.93	+9.45
3	+7.45	+7.14
4	+7.87	+3.71
5	+10.46	+1.52
6	+10.39	-1.88
7	+7.90	-4.29
8	+7.34	-7.67
9	+3.15	-10.08
10	0	-8.81
11	-3.15	-10.08
12	-7.34	-7.67
13	-7.90	-4.29
14	-10.39	-1.88

Cavity marking	X (mm)	Y (mm)
15	-10.46	+1.52
16	-7.87	+3.71
17	-7.45	+7.14
18	-4.93	+9.45
19	-1.70	+10.46
20	+3.20	+5.08
21	+6.71	-0.08
22	+3.18	-5.26
23	-3.18	-5.26
24	-6.71	-0.08
25	-3.20	+5.08
26	+2.24	-0.08
27	-2.24	-0.08

21-29

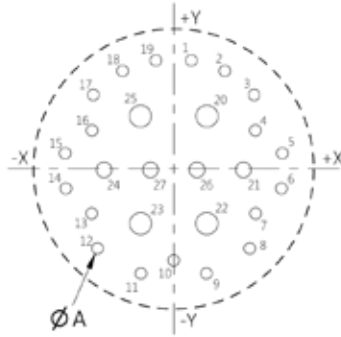

19 Contacts Size 20
4 Contacts Size 16
4 Contacts Size 12

Cavity marking	X (mm)	Y (mm)
1	+1.35	+10.82
2	+3.71	+10.26
3	+5.89	+9.19
4	+7.77	+7.67
5	+9.27	+5.77
6	+10.31	+3.58
7	+10.85	+1.22
8	+10.85	-1.22
9	+10.31	-3.58
10	+9.27	-5.77
11	+7.77	-7.67
12	+5.89	-9.19
13	+3.71	-10.26
14	+1.35	-10.82
15	-1.35	-10.82
16	-3.71	-10.26
17	-5.89	-9.19
18	-7.77	-7.67
19	-9.27	-5.77
20	-10.31	-3.58

Cavity marking	X (mm)	Y (mm)
21	-10.85	-1.22
22	-10.85	+1.22
23	-10.31	+3.58
24	-9.27	+5.77
25	-7.77	+7.67
26	-5.89	+9.19
27	-3.71	+10.26
28	-1.35	+10.82
29	0	+8.20
30	+2.49	+8.18
31	+4.67	+7.11
32	+6.55	+5.59
33	+7.90	+3.58
34	+8.43	+1.22
35	+8.43	-1.22
36	+7.90	-3.58
37	+6.55	-5.59
38	+4.67	-7.11
39	+2.49	-8.18
40	0	-8.81

Cavity marking	X (mm)	Y (mm)
41	-2.49	-8.18
42	-4.67	-7.11
43	-6.55	-5.59
44	-7.90	-3.58
45	-8.43	-1.22
46	-8.43	+1.22
47	-7.90	+3.58
48	-6.55	+5.59
49	-4.67	+7.11
50	-2.49	+8.18
51	-1.22	+6.12
52	+1.22	+6.12
53	+3.40	+5.05
54	+5.28	+3.53
55	+6.02	+1.22
56	+6.02	-1.22
57	+5.28	-3.53
58	+3.40	-5.05
59	+1.22	-6.12
60	-1.22	-6.12

Cavity marking	X (mm)	Y (mm)
61	-3.40	-5.05
62	-5.28	-3.53
63	-6.02	-1.22
64	-6.02	+1.22
65	-5.28	+3.53
66	-3.40	+5.05
67	-1.22	+3.71
68	+1.22	+3.71
69	+3.18	+2.29
70	+3.94	0
71	+3.18	-2.29
72	+1.22	-3.71
73	-1.22	-3.71
74	-3.18	-2.29
75	-3.94	0
76	-3.18	+2.29
77	0	+1.35
78	+1.22	-0.74
79	-1.22	-0.74

21-35

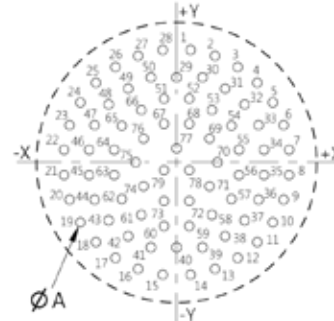

79 Contacts Size 22D

STANDARD RANGE

PRINTED CIRCUIT BOARD CONNECTORS

21

Cavity marking	X (mm)	Y (mm)
A	+1.65	+10.44
B	+4.80	+9.42
C	+7.47	+7.47
D	+9.42	+4.80
E	+10.44	+1.65
F	+10.44	-1.65
G	+9.42	-4.80
H	+7.47	-7.47
J	+4.80	-9.42
K	+1.65	-10.44
L	-1.65	-10.44
M	-4.80	-9.42
N	-7.47	-7.47
P	-9.42	-4.80
R	-10.44	-1.65
S	-10.44	+1.65
T	-9.42	+4.80
U	-7.47	+7.47
V	-4.80	+9.42
W	-1.65	+10.44

Cavity marking	X (mm)	Y (mm)
X	0	+7.49
Y	+3.20	+6.50
Z	+5.89	+4.55
a	+7.11	+1.45
b	+7.11	-1.88
c	+5.51	-4.80
d	+2.84	-6.73
e	-2.84	-6.73
f	-5.51	-4.80
g	-7.11	-1.88
h	-7.11	+1.45
i	-5.89	+4.55
j	-3.20	+6.50
k	0	+4.17
m	+2.90	+1.22
n	+2.69	-2.72
p	0	-4.80
q	-2.69	-2.72
r	-2.90	+1.09

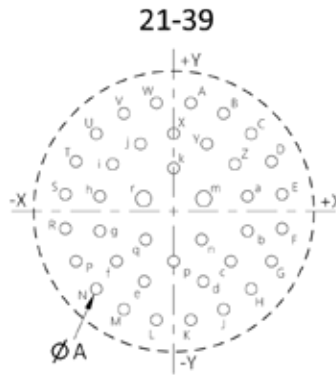

37 Contacts Size 20
2 Contacts Size 16

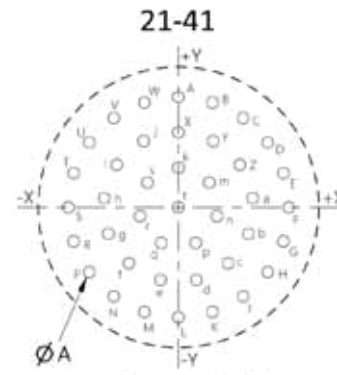

41 Contacts Size 20

Cavity marking	X (mm)	Y (mm)
A	0	+10.60
B	+3.28	+10.09
C	+6.23	+8.58
D	+8.58	+6.23
E	+10.09	+3.28
F	+10.60	0
G	+10.09	-3.28
H	+8.58	-6.23
J	+6.23	-8.58
K	+3.28	-10.09
L	0	-10.60
M	-3.28	-10.09
N	-6.23	-8.58
P	-8.58	-6.23
R	-10.09	-3.28
S	-10.60	0
T	-10.09	+3.28
U	-8.58	+6.23
V	-6.23	+8.58
W	-3.28	+10.09
X	0	+7.20

Cavity marking	X (mm)	Y (mm)
Y	+3.35	+6.38
Z	+5.92	+4.09
a	+7.15	+0.87
b	+6.73	-2.55
c	+4.78	-5.39
d	+1.73	-6.99
e	-1.73	-6.99
f	-4.78	-5.39
g	-6.73	-2.55
h	-7.15	+0.87
i	-5.92	+4.09
j	-3.35	+6.38
k	0	+3.81
m	+2.98	+2.38
n	+3.71	-0.85
p	+1.66	-3.43
q	-1.66	-3.43
r	-3.71	-0.85
s	-2.98	+2.38
t	0	0

21-121

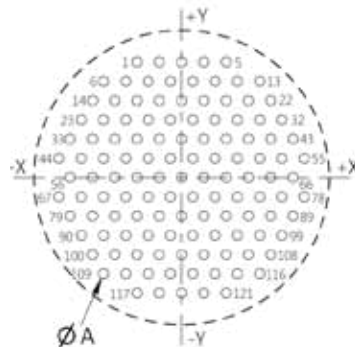

121 Contacts Size 23

Cavity marking	X (mm)	Y (mm)
1	-4.08	+10.60
2	-2.04	+10.60
3	0	+10.60
4	+2.04	+10.60
5	+4.08	+10.60
6	-7.14	+8.83
7	-5.10	+8.83
8	-3.06	+8.83
9	-1.02	+8.83
10	+1.02	+8.83
11	+3.06	+8.83
12	+5.10	+8.83
13	+7.14	+8.83
14	-8.16	+7.07
15	-6.12	+7.07
16	-4.08	+7.07
17	-2.04	+7.07
18	0	+7.07
19	+2.04	+7.07
20	+4.08	+7.07
21	+6.12	+7.07

Cavity marking	X (mm)	Y (mm)
22	+8.16	+7.07
23	-9.18	+5.30
24	-7.14	+5.30
25	-5.10	+5.30
26	-3.06	+5.30
27	-1.02	+5.30
28	+1.02	+5.30
29	+3.06	+5.30
30	+5.10	+5.30
31	+7.14	+5.30
32	+9.18	+5.30
33	-10.20	+3.53
34	-8.16	+3.53
35	-6.12	+3.53
36	-4.08	+3.53
37	-2.04	+3.53
38	0	+3.53
39	+2.04	+3.53
40	+4.08	+3.53
41	+6.12	+3.53
42	+8.16	+3.53

Cavity marking	X (mm)	Y (mm)
43	+10.20	+3.53
44	-11.22	+1.77
45	-9.18	+1.77
46	-7.14	+1.77
47	-5.10	+1.77
48	-3.06	+1.77
49	-1.02	+1.77
50	+1.02	+1.77
51	+3.06	+1.77
52	+5.10	+1.77
53	+7.14	+1.77
54	+9.18	+1.77
55	+11.22	+1.77
56	-10.20	0
57	-8.16	0
58	-6.12	0
59	-4.08	0
60	-2.04	0
61	0	0
62	+2.04	0
63	+4.08	0

Cavity marking	X (mm)	Y (mm)
64	+6.12	0
65	+8.16	0
66	+10.20	0
67	-11.22	-1.77
68	-9.18	-1.77
69	-7.14	-1.77
70	-5.10	-1.77
71	-3.06	-1.77
72	-1.02	-1.77
73	+1.02	-1.77
74	+3.06	-1.77
75	+5.10	-1.77
76	+7.14	-1.77
77	+9.18	-1.77
78	+11.22	-1.77
79	-10.20	-3.53
80	-8.16	-3.53
81	-6.12	-3.53
82	-4.08	-3.53
83	-2.04	-3.53
84	0	-3.53

Cavity marking	X (mm)	Y (mm)
85	+2.04	-3.53
86	+4.08	-3.53
87	+6.12	-3.53
88	+8.16	-3.53
89	+10.20	-3.53
90	-9.18	-5.30
91	-7.14	-5.30
92	-5.10	-5.30
93	-3.06	-5.30
94	-1.02	-5.30
95	+1.02	-5.30
96	+3.06	-5.30
97	+5.10	-5.30
98	+7.14	-5.30
99	+9.18	-5.30
100	-8.16	-7.07
101	-6.12	-7.07
102	-4.08	-7.07
103	-2.04	-7.07
104	0	-7.07
105	+2.04	-7.07

Cavity marking	X (mm)	Y (mm)
106	+4.08	-7.07
107	+6.12	-7.07
108	+8.16	-7.07
109	-7.14	-8.83
110	-5.10	-8.83
111	-3.06	-8.83
112	-1.02	-8.83
113	+1.02	-8.83
114	+3.06	-8.83
115	+5.10	-8.83
116	+7.14	-8.83
117	-4.08	-10.60
118	-2.04	-10.60
119	0	-10.60
120	+2.04	-10.60
121	+4.08	-10.60

STANDARD RANGE

PRINTED CIRCUIT BOARD CONNECTORS

23

Cavity marking	X (mm)	Y (mm)
1	-10.87	+6.12
2	-11.86	+3.91
3	-12.40	+1.55
4	-10.54	0
5	-12.40	-1.55
6	-10.87	-3.61
7	-10.87	-6.02
8	-8.43	+8.46
9	-8.43	+6.05
10	-8.43	+3.63
11	-8.43	+1.22
12	-8.43	-1.19
13	-8.43	-3.61
14	-8.43	-6.02
15	-8.43	-8.43
16	-6.32	+9.65
17	-6.32	+7.24
18	-6.32	+4.83
19	-6.32	+2.41
20	-6.32	0

Cavity marking	X (mm)	Y (mm)
21	-6.32	-2.41
22	-6.32	-4.83
23	-6.32	-7.24
24	-6.32	-9.65
25	-4.22	+10.87
26	-4.22	+8.46
27	-4.22	+6.05
28	-4.22	+3.63
29	-4.22	+1.22
30	-4.22	-1.19
31	-4.22	-3.61
32	-4.22	-6.02
33	-4.22	-8.43
34	-4.22	-10.85
35	-2.11	+12.07
36	-2.11	+9.65
37	-2.11	+7.24
38	-2.11	+4.83
39	-2.11	+2.41
40	-2.11	0

Cavity marking	X (mm)	Y (mm)
41	-2.11	-2.41
42	-2.11	-4.83
43	-2.11	-7.24
44	-2.11	-9.65
45	-2.11	-12.07
46	0	+10.87
47	0	+8.46
48	0	+6.05
49	0	+3.63
50	0	+1.22
51	0	-1.19
52	0	-3.61
53	0	-6.02
54	0	-8.43
55	0	-10.85
56	+2.11	+12.07
57	+2.11	+9.65
58	+2.11	+7.24
59	+2.11	+4.83
60	+2.11	+2.41

Cavity marking	X (mm)	Y (mm)
61	+2.11	0
62	+2.11	-2.41
63	+2.11	-4.83
64	+2.11	-7.24
65	+2.11	-9.65
66	+2.11	-12.07
67	+4.22	+10.87
68	+4.22	+8.46
69	+4.22	+6.05
70	+4.22	+3.63
71	+4.22	+1.22
72	+4.22	-1.19
73	+4.22	-3.61
74	+4.22	-6.02
75	+4.22	-8.43
76	+4.22	-10.85
77	+6.32	+9.65
78	+6.32	+7.24
79	+6.32	+4.83
80	+6.32	+2.41

Cavity marking	X (mm)	Y (mm)
81	+6.32	0
82	+6.32	-2.41
83	+6.32	-4.83
84	+6.32	-7.24
85	+6.32	-9.65
86	+8.43	+8.46
87	+8.43	+6.05
88	+8.43	+3.63
89	+8.43	+1.22
90	+8.43	-1.19
91	+8.43	-3.61
92	+8.43	-6.02
93	+8.43	-8.43
94	+10.87	+6.12
95	+11.86	+3.91
96	+12.40	+1.55
97	+10.54	0
98	+12.40	-1.55
99	+10.87	-3.61
100	+10.87	-6.02

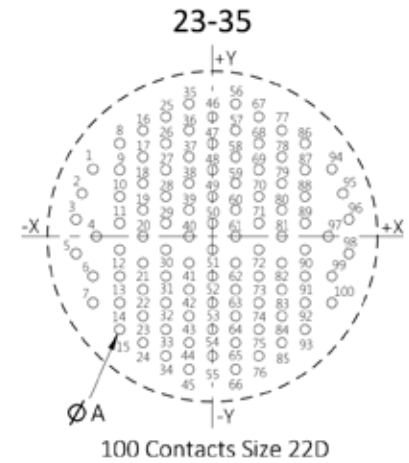

Cavity marking	X (mm)	Y (mm)
A	+2.84	+11.56
B	+5.72	+9.91
C	+8.53	+8.26
D	+11.43	+3.30
E	+11.43	0
F	+11.43	-3.30
G	+8.53	-8.26
H	+5.72	-10.41
J	-5.72	-10.41
K	-8.53	-8.26
L	-11.43	-3.30
M	-11.43	0
N	-11.43	+3.30
P	-8.53	+8.26
R	-5.72	+9.91
S	-2.84	+11.56
T	0	+9.91
U	+2.84	+8.26

Cavity marking	X (mm)	Y (mm)
V	+5.72	+6.60
W	+8.53	+4.95
X	+8.53	+1.65
Y	+8.53	-1.65
Z	+8.53	-4.95
a	+5.72	-6.60
b	+2.84	-8.26
c	0	-9.91
d	-2.84	-8.26
e	-5.72	-6.60
f	-8.53	-4.95
g	-8.53	-1.65
h	-8.53	+1.65
k	-8.53	+4.95
m	-5.72	+6.60
n	-2.84	+8.26
p	0	+6.60
q	+2.84	+4.95

Cavity marking	X (mm)	Y (mm)
r	+5.72	+3.30
s	+5.72	0
t	+5.72	-3.30
u	+2.84	-4.95
v	0	-6.60
w	-2.84	-4.95
x	-5.72	-3.30
y	-5.72	0
z	-5.72	+3.30
AA	-2.84	+4.95
BB	0	+3.30
CC	+2.84	+1.65
DD	+2.84	-1.65
EE	0	-3.30
FF	-2.84	-1.65
GG	-2.84	+1.65
HH	0	0

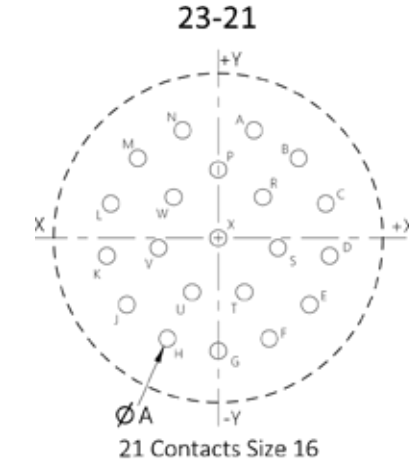
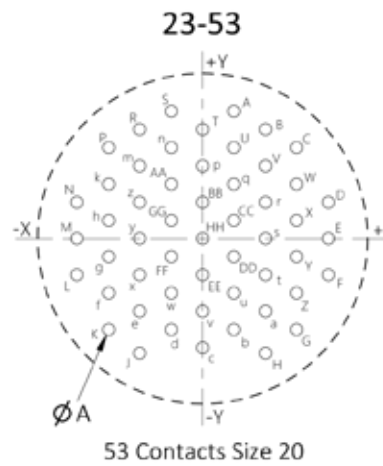

Cavity marking	X (mm)	Y (mm)
1	+3.61	+11.71
2	+5.74	+10.72
3	+7.65	+9.45
4	+9.45	+7.85
5	+10.72	+5.74
6	+11.71	+3.61
7	+11.71	-3.61
8	+10.72	-5.74
9	+9.45	-7.65
10	+7.65	-9.45
11	+5.74	-10.72
12	+3.61	-11.71
13	-3.61	-11.71
14	-5.74	-10.72
15	-7.65	-9.45
16	-9.45	-7.65
17	-10.72	-5.74
18	-11.71	-3.61

Cavity marking	X (mm)	Y (mm)
19	-11.71	+3.61
20	-10.72	+5.74
21	-9.45	+7.65
22	-7.65	+9.45
23	-5.74	+10.72
24	-3.61	+11.71
25	0	+9.60
26	+4.11	+8.97
27	+6.07	+7.77
28	+7.77	+6.07
29	+8.97	+4.11
30	+9.60	0
31	+8.97	-4.11
32	+7.77	-6.07
33	+6.07	-7.77
34	+4.11	-8.97
35	0	-9.60
36	-4.11	-8.97

Cavity marking	X (mm)	Y (mm)
37	-6.07	-7.77
38	-7.77	-6.07
39	-8.97	-4.11
40	-9.60	0
41	-8.97	+4.11
42	-7.77	+6.07
43	-6.07	+7.77
44	-4.11	+8.97
45	0	+4.37
46	+4.37	+4.37
47	+4.37	0
48	+4.37	-4.37
49	0	-4.37
50	-4.37	-4.37
51	-4.37	0
52	-4.37	+4.37
53	0	0

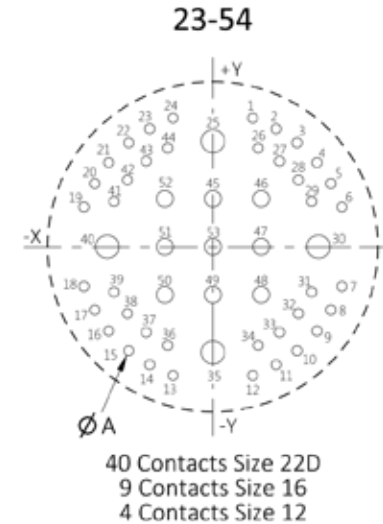

Cavity marking	X (mm)	Y (mm)
A	+3.25	+9.78
B	+7.34	+7.24
C	+9.80	+3.12
D	+10.16	-1.65
E	+8.33	-6.07
F	+4.65	-9.19
G	0	-10.31
H	-4.65	-9.19
J	-8.33	-6.07
K	-10.16	-1.65
L	-9.80	+3.12
M	-7.34	+7.24
N	-3.25	+9.78
P	0	+6.22
R	+4.06	+3.71
S	+5.44	-0.89
T	+2.39	-4.93
U	-2.39	-4.93
V	-5.44	-0.89
W	-4.06	+3.71
X	0	0

STANDARD RANGE

PRINTED CIRCUIT BOARD CONNECTORS

23

Cavity marking	X (mm)	Y (mm)
A	+2.84	+11.56
B	+5.72	+9.91
C	+8.53	+8.26
D	+11.43	+3.30
E	+11.43	0
F	+11.43	-3.30
G	+8.53	-8.26
H	+5.72	-9.91
J	+2.84	-11.56
K	-2.84	-11.56
L	-5.72	-9.91
M	-8.53	-8.26
N	-11.43	-3.30
P	-11.43	0
R	-11.43	+3.30
S	-8.53	+8.26
T	-5.72	+9.91
U	-2.84	+11.56
V	0	+9.91

Cavity marking	X (mm)	Y (mm)
W	+2.84	+8.26
X	+5.72	+6.60
Y	+8.53	+4.95
Z	+8.53	+1.65
a	+8.53	-1.65
b	+8.53	-4.95
c	+5.72	-6.60
d	+2.84	-8.26
e	0	-9.91
f	-2.84	-8.26
g	-5.72	-6.60
h	-8.53	-4.95
i	-8.53	-1.65
j	-8.53	+1.65
k	-8.53	+4.95
m	-5.72	+6.60
n	-2.84	+8.26
p	0	+6.60
q	+2.84	+4.95

Cavity marking	X (mm)	Y (mm)
r	+5.72	+3.30
s	+5.72	0
t	+5.72	-3.30
u	+2.84	-4.95
v	0	-6.60
w	-2.84	-4.95
x	-5.72	-3.30
y	-5.72	0
z	-5.72	+3.30
AA	-2.84	+4.95
BB	0	+3.30
CC	+2.84	+1.65
DD	+2.84	-1.65
EE	0	-3.30
FF	-2.84	-1.65
GG	-2.84	+1.65
HH	0	0

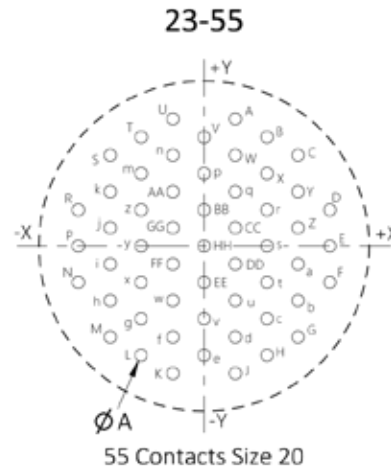

55 Contacts Size 20

23-151

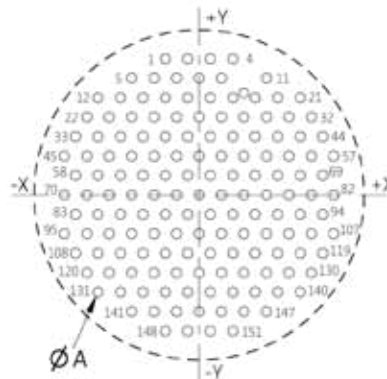

151 Contacts Size 23

Cavity marking	X (mm)	Y (mm)
1	-3.06	+12.37
2	-1.02	+12.37
3	+1.02	+12.37
4	+3.06	+12.37
5	-6.12	+10.60
6	-4.08	+10.60
7	-2.04	+10.60
8	0	+10.60
9	+2.04	+10.60
10	+4.08	+10.60
11	+6.12	+10.60
12	-9.18	+8.83
13	-7.14	+8.83
14	-5.10	+8.83
15	-3.06	+8.83
16	-1.02	+8.83
17	+1.02	+8.83
18	+3.06	+8.83
19	+5.10	+8.83
20	+7.14	+8.83
21	+9.18	+8.83
22	+10.20	+7.07

Cavity marking	X (mm)	Y (mm)
23	-8.16	+7.07
24	-6.12	+7.07
25	-4.08	+7.07
26	-2.04	+7.07
27	0	+7.07
28	+2.04	+7.07
29	+4.08	+7.07
30	+6.12	+7.07
31	+8.16	+7.07
32	+10.20	+7.07
33	-11.22	+5.30
34	-9.18	+5.30
35	-7.14	+5.30
36	-5.10	+5.30
37	-3.06	+5.30
38	-1.02	+5.30
39	+1.02	+5.30
40	+3.06	+5.30
41	+5.10	+5.30
42	+7.14	+5.30
43	+9.18	+5.30
44	+11.22	+5.30

Cavity marking	X (mm)	Y (mm)
45	-12.24	+3.53
46	-10.20	+3.53
47	-8.16	+3.53
48	-6.12	+3.53
49	-4.08	+3.53
50	-2.04	+3.53
51	0	+3.53
52	+2.04	+3.53
53	+4.08	+3.53
54	+6.12	+3.53
55	+8.16	+3.53
56	+10.20	+3.53
57	+12.24	+3.53
58	-11.22	+1.77
59	-9.18	+1.77
60	-7.14	+1.77
61	-5.10	+1.77
62	-3.06	+1.77
63	-1.02	+1.77
64	+1.02	+1.77
65	+3.06	+1.77
66	+5.10	+1.77

Cavity marking	X (mm)	Y (mm)
67	+7.14	+1.77
68	+9.18	+1.77
69	+11.22	+1.77
70	-12.24	0
71	-10.20	0
72	-8.16	0
73	-6.12	0
74	-4.08	0
75	-2.04	0
76	0	0
77	+2.04	0
78	+4.08	0
79	+6.12	0
80	+8.16	0
81	+10.20	0
82	+12.24	0
83	-11.22	-1.77
84	-9.18	-1.77
85	-7.14	-1.77
86	-5.10	-1.77
87	-3.06	-1.77
88	-1.02	-1.77

Cavity marking	X (mm)	Y (mm)
89	+1.02	-1.77
90	+3.06	-1.77
91	+5.10	-1.77
92	+7.14	-1.77
93	+9.18	-1.77
94	+11.22	-1.77
95	-12.24	-3.53
96	-10.20	-3.53
97	-8.16	-3.53
98	-6.12	-3.53
99	-4.08	-3.53
100	-2.04	-3.53
101	0	-3.53
102	+2.04	-3.53
103	+4.08	-3.53
104	+6.12	-3.53
105	+8.16	-3.53
106	+10.20	-3.53
107	+12.24	-3.53
108	-11.22	-5.30
109	-9.18	-5.30
110	-7.14	-5.30

Cavity marking	X (mm)	Y (mm)
111	-5.10	-5.30
112	-3.06	-5.30
113	-1.02	-5.30
114	+1.02	-5.30
115	+3.06	-5.30
116	+5.10	-5.30
117	+7.14	-5.30
118	+9.18	-5.30
119	+11.22	-5.30
120	-10.20	-7.07
121	-8.16	-7.07
122	-6.12	-7.07
123	-4.08	-7.07
124	-2.04	-7.07
125	0	-7.07
126	+2.04	-7.07
127	+4.08	-7.07
128	+6.12	-7.07
129	+8.16	-7.07
130	+10.20	-7.07
131	-9.18	-8.83
132	-7.14	-8.83

Cavity marking	X (mm)	Y (mm)
133	-5.10	-8.83
134	-3.06	-8.83
135	-1.02	-8.83
136	+1.02	-8.83
137	+3.06	-8.83
138	+5.10	-8.83
139	+7.14	-8.83
140	+9.18	-8.83
141	-6.12	-10.60
142	-4.08	-10.60
143	-2.04	-10.60
144	0	-10.60
145	+2.04	-10.60
146	+4.08	-10.60
147	+6.12	-10.60
148	-3.06	-12.37
149	-1.02	-12.37
150	+1.02	-12.37
151	+3.06	-12.37

STANDARD RANGE

PRINTED CIRCUIT BOARD CONNECTORS

25

Cavity marking	X (mm)	Y (mm)
A	0	+10.39
B	+5.99	+10.39
C	+8.99	+5.21
D	+11.99	0
E	+8.99	-5.21
F	+5.99	-10.39
G	0	-10.39
H	-5.99	-10.39
J	-8.99	-5.21
K	-11.99	0
L	-8.99	+5.21
M	-5.99	+10.39
N	-3.00	+5.21
P	+3.00	+5.21
R	+5.99	0
S	+3.00	-5.21
T	-3.00	-5.21
U	-5.99	0
V	0	0

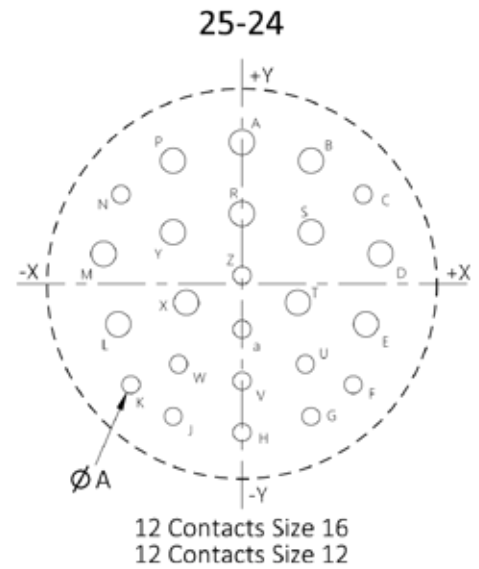
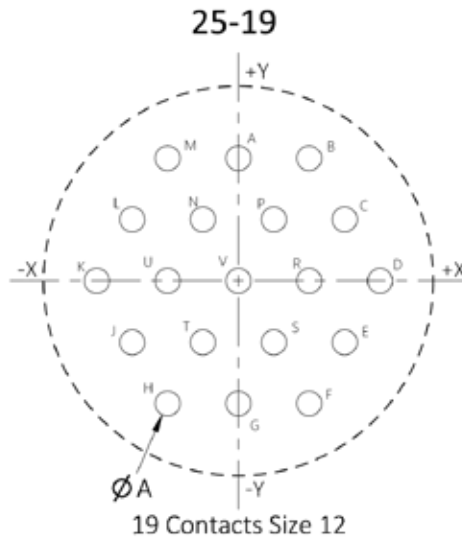

Cavity marking	X (mm)	Y (mm)
A	0	+11.99
B	+5.84	+10.41
C	+10.24	+7.57
D	+11.71	+2.54
E	+10.49	-3.40
F	+9.40	-8.53
G	+5.84	-11.20
H	0	-12.57
J	-5.84	-11.20
K	-9.40	-8.53
L	-10.49	-3.40
M	-11.71	+2.54

Cavity marking	X (mm)	Y (mm)
N	-10.24	+7.57
P	-5.84	+10.41
R	0	+5.94
S	+5.84	+4.37
T	+4.72	-1.57
U	+5.36	-6.78
V	0	-8.20
W	-5.36	-6.78
X	-4.72	-1.57
Y	-5.84	+4.37
Z	0	+0.71
a	0	-3.84

Cavity marking	X (mm)	Y (mm)
A	0	+12.22
B	+6.55	+10.31
C	+10.03	+7.04
D	+11.91	+2.77
E	+11.91	-2.77
F	+10.03	-7.04
G	+6.68	-10.31
H	+2.31	-11.99
J	-2.31	-11.99
K	-6.68	-10.31
L	-10.03	-7.04
M	-11.91	-2.77
N	-11.91	+2.77
P	-10.03	+7.04
R	-6.55	+10.31

Cavity marking	X (mm)	Y (mm)
S	-2.31	+8.15
T	+2.31	+8.15
U	+5.79	+4.93
V	+8.10	0
W	+6.10	-4.60
X	+2.31	-7.37
Y	-2.31	-7.37
Z	-6.10	-4.60
a	-8.10	0
b	-5.79	+4.93
c	0	+4.09
d	+3.40	0
e	0	-3.30
f	-3.40	0

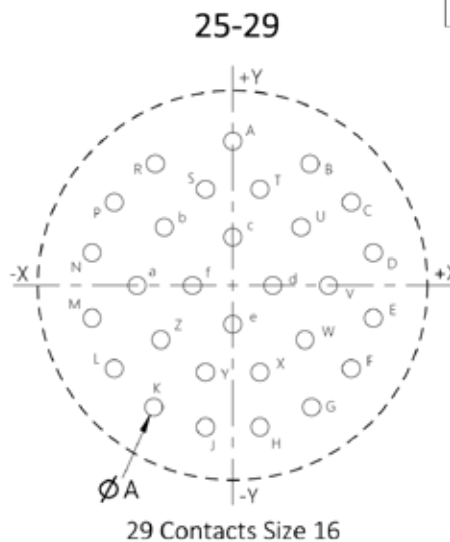

25

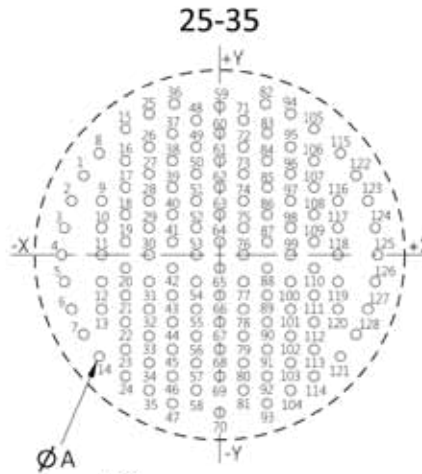

128 Contacts Size 22D

Cavity marking	X (mm)	Y (mm)
1	-12.17	+7.09
2	-13.21	+4.83
3	-13.87	+2.41
4	-14.10	0
5	-13.87	-2.41
6	-13.21	-4.83
7	-12.17	-7.09
8	-10.77	+9.07
9	-10.54	+4.83
10	-10.54	+2.41
11	-10.54	0
12	-10.54	-2.41
13	-10.54	-4.83
14	-10.77	-9.07
15	-8.43	+11.28
16	-8.43	+8.43
17	-8.43	+6.02
18	-8.43	+3.61
19	-8.43	+1.19
20	-8.43	-1.19
21	-8.43	-3.61
22	-8.43	-6.02

Cavity marking	X (mm)	Y (mm)
23	-8.43	-8.43
24	-8.43	-10.85
25	-6.32	+12.60
26	-6.32	+9.65
27	-6.32	+7.24
28	-6.32	+4.83
29	-6.32	+2.41
30	-6.32	0
31	-6.32	-2.41
32	-6.32	-4.83
33	-6.32	-7.24
34	-6.32	-9.65
35	-6.32	-12.07
36	-4.06	+13.49
37	-4.22	+10.85
38	-4.22	+8.43
39	-4.22	+6.02
40	-4.22	+3.61
41	-4.22	+1.19
42	-4.22	-1.19
43	-4.22	-3.61
44	-4.22	-6.02

Cavity marking	X (mm)	Y (mm)
45	-4.22	-8.43
46	-4.22	-10.85
47	-4.22	-13.26
48	-2.11	+12.07
49	-2.11	+9.65
50	-2.11	+7.24
51	-2.11	+4.83
52	-2.11	+2.41
53	-2.11	0
54	-2.11	-2.41
55	-2.11	-4.83
56	-2.11	-7.24
57	-2.11	-9.65
58	-2.11	-12.07
59	0	+13.26
60	0	+10.85
61	0	+8.43
62	0	+6.02
63	0	+3.61
64	0	+1.19
65	0	-1.19
66	0	-3.61

Cavity marking	X (mm)	Y (mm)
67	0	-6.02
68	0	-8.43
69	0	-10.85
70	0	-14.10
71	+2.11	+12.07
72	+2.11	+9.65
73	+2.11	+7.24
74	+2.11	+4.83
75	+2.11	+2.41
76	+2.11	0
77	+2.11	-2.41
78	+2.11	-4.83
79	+2.11	-7.24
80	+2.11	-9.65
81	+2.11	-12.07
82	+4.06	+13.49
83	+4.22	+10.85
84	+4.22	+8.43
85	+4.22	+6.02
86	+4.22	+3.61
87	+4.22	+1.19
88	+4.22	-1.19

Cavity marking	X (mm)	Y (mm)
89	+4.22	-3.61
90	+4.22	-6.02
91	+4.22	-8.43
92	+4.22	-10.85
93	+4.22	-13.26
94	+6.32	+12.60
95	+6.32	+9.65
96	+6.32	+7.24
97	+6.32	+4.83
98	+6.32	+2.41
99	+6.32	0
100	+6.32	-2.41
101	+6.32	-4.83
102	+6.32	-7.24
103	+6.32	-9.65
104	+6.32	-12.07
105	+8.43	+11.28
106	+8.43	+8.43
107	+8.43	+6.02
108	+8.43	+3.61
109	+8.43	+1.19
110	+8.43	-1.19

Cavity marking	X (mm)	Y (mm)
111	+8.43	-3.61
112	+8.43	-6.02
113	+8.43	-8.43
114	+8.43	-10.85
115	+10.77	+9.07
116	+10.54	+4.83
117	+10.54	+2.41
118	+10.54	0
119	+10.54	-2.41
120	+10.54	-4.83
121	+10.77	-9.07
122	+12.17	+7.09
123	+13.21	+4.83
124	+13.87	+2.41
125	+14.10	0
126	+13.87	-2.41
127	+13.21	-4.83
128	+12.17	-7.09

25-37

Cavity marking	X (mm)	Y (mm)
A	0	+11.99
B	+4.70	+11.99
C	+8.46	+9.70
D	+11.20	+6.32
E	+12.70	+2.18
F	+12.70	-2.18
G	+11.20	-6.32
H	+8.46	+9.70
J	+4.72	-11.99
K	0	-11.99
L	-4.72	-11.99
M	-8.46	-9.70
N	-11.20	-6.32
P	-12.70	-2.18
R	-12.70	+2.18
S	-11.20	+6.32
T	-8.46	+9.70
U	-4.72	+11.99
V	+2.18	+8.13

Cavity marking	X (mm)	Y (mm)
W	+6.15	+5.99
X	+8.28	+2.18
Y	+8.28	-2.18
Z	+6.15	-5.99
a	+2.18	-8.13
b	-2.18	-8.13
c	-6.15	-5.99
d	-8.28	-2.18
e	-8.28	+2.18
f	-6.15	+5.99
g	-2.18	+8.13
h	0	+4.37
k	+3.91	+2.18
m	+3.91	-2.18
n	0	-4.37
p	-3.91	-2.18
q	-3.91	+2.18
r	0	0

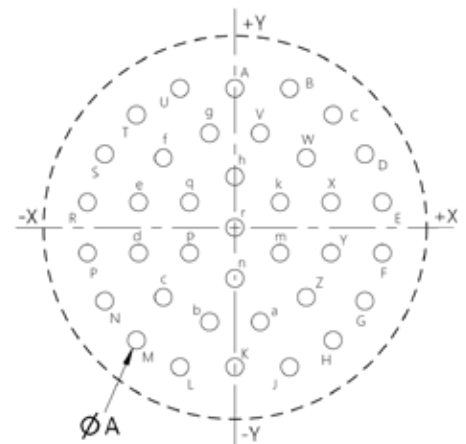

37 Contacts Size 16

STANDARD RANGE

PRINTED CIRCUIT BOARD CONNECTORS

25

Cavity marking	X (mm)	Y (mm)	Cavity marking	X (mm)	Y (mm)	Cavity marking	X (mm)	Y (mm)
A	+1.75	+13.49	W	-12.52	+5.21	t	-9.58	+3.35
B	+5.16	+12.57	X	-10.77	+8.28	u	-7.90	+6.38
C	+8.23	+10.80	Y	-8.23	+10.80	v	-5.38	+8.74
D	+10.77	+8.28	Z	-5.16	+12.57	w	-2.18	+10.08
E	+12.52	+5.21	a	-1.75	+13.49	x	+1.75	+6.68
F	+13.49	+1.75	b	+2.18	+10.08	y	+4.37	+3.78
G	+13.49	-1.75	c	+5.38	+8.74	z	+6.55	0
H	+12.52	-5.21	d	+7.90	+6.38	AA	+4.37	-3.78
J	+10.77	-8.28	e	+9.58	+3.35	BB	+1.75	-6.68
K	+8.23	-10.80	f	+10.46	0	CC	-1.75	-6.68
L	+5.16	-12.57	g	+9.58	-3.35	DD	-4.37	-3.78
M	+1.75	-13.49	h	+7.90	-6.38	EE	-6.55	0
N	-1.75	-13.49	k	+5.38	-8.74	FF	-4.37	+3.78
P	-5.16	-12.57	m	+2.18	-10.08	GG	-1.75	+6.68
R	-8.23	-10.80	n	-2.18	-10.08	HH	0	+3.35
S	-10.77	-8.28	p	-5.38	-8.74	JJ	+2.18	0
T	-12.52	-5.21	q	-7.90	-6.38	KK	0	-3.35
U	-13.49	-1.75	r	-9.58	-3.35	LL	-2.18	0
V	-13.49	+1.75	s	-10.46	0			

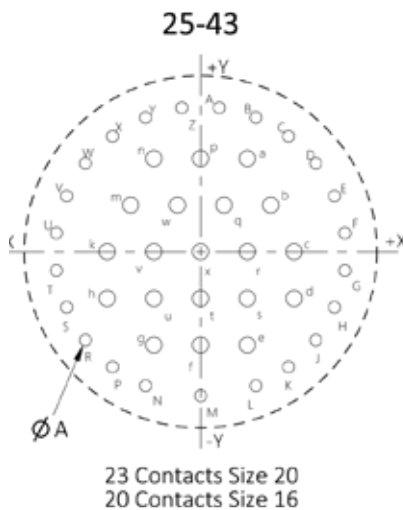
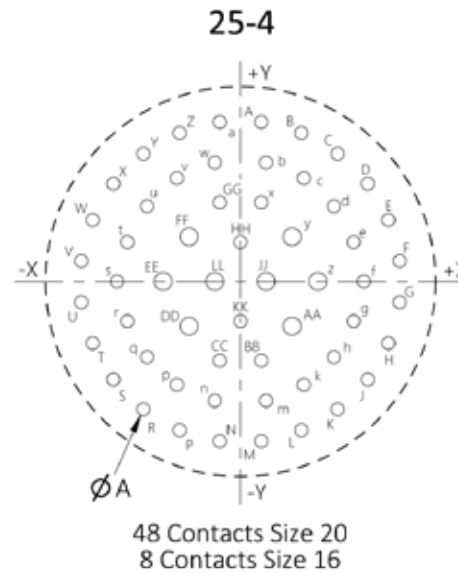

Cavity marking	X (mm)	Y (mm)	Cavity marking	X (mm)	Y (mm)
A	+1.75	+13.49	Z	-1.75	+13.49
B	+5.16	+12.57	a	+4.37	+8.74
C	+8.23	+10.80	b	+6.55	+4.37
D	+10.77	+8.28	c	+8.74	0
E	+12.52	+5.21	d	+8.74	-4.37
F	+13.49	+1.75	e	+4.37	-8.74
G	+13.49	-1.75	f	0	-8.74
H	+12.52	-5.21	g	-4.37	-8.74
J	+10.77	-8.28	h	-8.74	-4.37
K	+8.23	-10.80	k	-8.74	0
L	+5.16	-12.57	m	-6.55	+4.37
M	0	-13.49	n	-4.37	+8.74
N	-5.16	-12.57	p	0	+8.74
P	-8.23	-10.80	q	+2.18	+4.37
R	-10.77	-8.28	r	+4.37	0
S	-12.52	-5.21	s	+4.37	-4.37
T	-13.49	-1.75	t	0	-4.37
U	-13.49	+1.75	u	-4.37	-4.37
V	-12.52	+5.21	v	-4.37	0
W	-10.77	+8.28	w	-2.18	+4.37
X	-8.23	+10.80	x	0	0
Y	-5.16	+12.57			

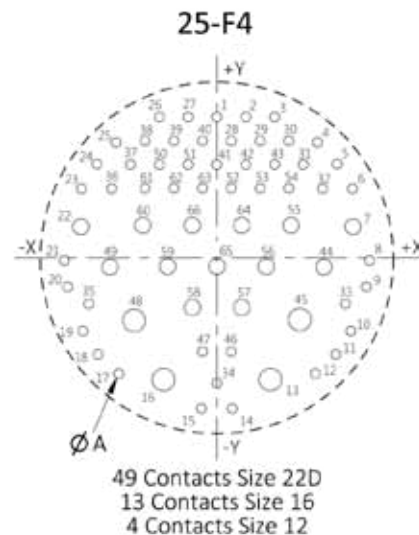

Cavity marking	X (mm)	Y (mm)	Cavity marking	X (mm)	Y (mm)	Cavity marking	X (mm)	Y (mm)
1	0	+13.18	23	-12.67	+6.48	45	+7.75	-5.89
2	+2.69	+13.18	24	-11.23	+8.79	46	+1.35	-8.81
3	+5.38	+13.18	25	-9.42	+10.82	47	-1.35	-8.81
4	+9.42	+10.82	26	-5.38	+13.18	48	-7.75	-5.89
5	+11.23	+8.79	27	-2.69	+13.18	49	-10.01	-0.86
6	+12.67	+6.48	28	+1.35	+10.97	50	-5.38	+8.74
7	+12.73	+2.92	29	+4.04	+10.97	51	-2.69	+8.74
8	+14.27	-0.25	30	+6.73	+10.97	52	+1.35	+6.53
9	+13.97	-2.72	31	+8.08	+8.74	53	+4.04	+6.53
10	+12.52	-6.86	32	+9.86	+6.48	54	+6.73	+6.53
11	+11.10	-9.07	33	+11.99	-4.32	55	+6.93	+3.05
12	+9.19	-10.87	34	0	-11.79	56	+4.62	-0.81
13	+5.00	-11.43	35	-11.99	-4.32	57	+2.31	-4.67
14	+1.45	-14.15	36	-9.86	+6.48	58	-2.31	-4.67
15	-1.45	-14.15	37	-8.08	+8.74	59	-4.62	-0.81
16	-5.00	-11.43	38	-6.73	+10.97	60	-6.93	+3.05
17	-9.19	-10.87	39	-4.04	+10.97	61	-6.73	+6.53
18	-11.10	-9.07	40	-1.35	+10.97	62	-4.04	+6.53
19	-12.52	-6.86	41	0	+8.74	63	-1.35	+6.53
20	-13.97	-2.72	42	+2.69	+8.74	64	+2.31	+3.05
21	-14.27	-0.25	43	+5.38	+8.74	65	0	-0.81
22	-12.73	+2.92	44	+10.01	-0.86	66	-2.31	+3.05

STANDARD RANGE

PRINTED CIRCUIT BOARD CONNECTORS

25

Cavity marking	X (mm)	Y (mm)	Cavity marking	X (mm)	Y (mm)	Cavity marking	X (mm)	Y (mm)	Cavity marking	X (mm)	Y (mm)	Cavity marking	X (mm)	Y (mm)	Cavity marking	X (mm)	Y (mm)
1	-2.04	+14.13	22	-9.18	+8.83	43	+8.16	+7.07	64	-4.08	+3.53	85	+11.22	+1.77	106	-5.10	-1.77
2	0	+14.13	23	-7.14	+8.83	44	+10.20	+7.07	65	-2.04	+3.53	86	+13.26	+1.77	107	-3.06	-1.77
3	+2.04	+14.13	24	-5.10	+8.83	45	+12.24	+7.07	66	0	+3.53	87	-14.28	0	108	-1.02	-1.77
4	-7.14	+12.37	25	-3.06	+8.83	46	-13.26	+5.30	67	+2.04	+3.53	88	-12.24	0	109	+1.02	-1.77
5	-5.10	+12.37	26	-1.02	+8.83	47	-11.22	+5.30	68	+4.08	+3.53	89	-10.20	0	110	+3.06	-1.77
6	-3.06	+12.37	27	+1.02	+8.83	48	-9.18	+5.30	69	+6.12	+3.53	90	-8.16	0	111	+5.10	-1.77
7	-1.02	+12.37	28	+3.06	+8.83	49	-7.14	+5.30	70	+8.16	+3.53	91	-6.12	0	112	+7.14	-1.77
8	+1.02	+12.37	29	+5.10	+8.83	50	-5.10	+5.30	71	+10.20	+3.53	92	-4.08	0	113	+9.18	-1.77
9	+3.06	+12.37	30	+7.14	+8.83	51	-3.06	+5.30	72	+12.24	+3.53	93	-2.04	0	114	+11.22	-1.77
10	+5.10	+12.37	31	+9.18	+8.83	52	-1.02	+5.30	73	-13.26	+1.77	94	0	0	115	+13.26	-1.77
11	+7.14	+12.37	32	+11.22	+8.83	53	+1.02	+5.30	74	-11.22	+1.77	95	+2.04	0	116	-12.24	-3.53
12	-8.16	+10.60	33	-12.24	+7.07	54	+3.06	+5.30	75	-9.18	+1.77	96	+4.08	0	117	-10.20	-3.53
13	-6.12	+10.60	34	-10.20	+7.07	55	+5.10	+5.30	76	-7.14	+1.77	97	+6.12	0	118	-8.16	-3.53
14	-4.08	+10.60	35	-8.16	+7.07	56	+7.14	+5.30	77	-5.10	+1.77	98	+8.16	0	119	-6.12	-3.53
15	-2.04	+10.60	36	-6.12	+7.07	57	+9.18	+5.30	78	-3.06	+1.77	99	+10.20	0	120	-4.08	-3.53
16	0	+10.60	37	-4.08	+7.07	58	+11.22	+5.30	79	-1.02	+1.77	100	+12.24	0	121	-2.04	-3.53
17	+2.04	+10.60	38	-2.04	+7.07	59	+13.26	+5.30	80	+1.02	+1.77	101	+14.28	0	122	0	-3.53
18	+4.08	+10.60	39	0	+7.07	60	-12.24	+3.53	81	+3.06	+1.77	102	-13.26	-1.77	123	+2.04	-3.53
19	+6.12	+10.60	40	+2.04	+7.07	61	-10.20	+3.53	82	+5.10	+1.77	103	-11.22	-1.77	124	+4.08	-3.53
20	+8.16	+10.60	41	+4.08	+7.07	62	-8.16	+3.53	83	+7.14	+1.77	104	-9.18	-1.77	125	+6.12	-3.53
21	-11.22	+8.83	42	+6.12	+7.07	63	-6.12	+3.53	84	+9.18	+1.77	105	-7.14	-1.77	126	+8.16	-3.53

Cavity marking	X (mm)	Y (mm)	Cavity marking	X (mm)	Y (mm)	Cavity marking	X (mm)	Y (mm)
127	+10.20	-3.53	148	-2.04	-7.07	169	-6.12	-10.60
128	+12.24	-3.53	149	0	-7.07	170	-4.08	-10.60
129	-13.26	-5.30	150	+2.04	-7.07	171	-2.04	-10.60
130	-11.22	-5.30	151	+4.08	-7.07	172	0	-10.60
131	-9.18	-5.30	152	+6.12	-7.07	173	+2.04	-10.60
132	-7.14	-5.30	153	+8.16	-7.07	174	+4.08	-10.60
133	-5.10	-5.30	154	+10.20	-7.07	175	+6.12	-10.60
134	-3.06	-5.30	155	+12.24	-7.07	176	+8.16	-10.60
135	-1.02	-5.30	156	-11.22	-8.83	177	-7.14	-12.37
136	+1.02	-5.30	157	-9.18	-8.83	178	-5.10	-12.37
137	+3.06	-5.30	158	-7.14	-8.83	179	-3.06	-12.37
138	+5.10	-5.30	159	-5.10	-8.83	180	-1.02	-12.37
139	+7.14	-5.30	160	-3.06	-8.83	181	+1.02	-12.37
140	+9.18	-5.30	161	-1.02	-8.83	182	+3.06	-12.37
141	+11.22	-5.30	162	+1.02	-8.83	183	+5.10	-12.37
142	+13.26	-5.30	163	+3.06	-8.83	184	+7.14	-12.37
143	-12.24	-7.07	164	+5.10	-8.83	185	-2.04	-14.13
144	-10.20	-7.07	165	+7.14	-8.83	186	0	-14.13
145	-8.16	-7.07	166	+9.18	-8.83	187	+2.04	-14.13
146	-6.12	-7.07	167	+11.22	-8.83			
147	-4.08	-7.07	168	-8.16	-10.60			

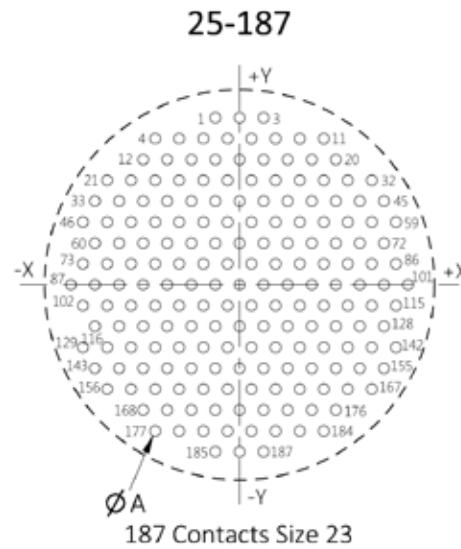

STANDARD RANGE

PRINTED CIRCUIT BOARD CONNECTORS

25

Cavity marking	X (mm)	Y (mm)
A	+4.96	+12.70
B	+7.96	+11.05
C	+10.49	+8.71
D	+12.32	+5.84
E	+13.39	+2.57
F	+13.61	-0.76
G	+12.98	-4.17
H	+11.53	-7.29
J	+9.35	-9.93
K	+6.58	-11.94
L	+3.40	-13.18
M	0	-13.64
N	-3.40	-13.18
P	-6.58	-11.94
R	-9.35	-9.93
S	-11.53	-7.29
T	-12.98	-4.17
U	-13.61	-0.76
V	-13.39	+2.57
W	-12.32	+5.84
X	-10.49	+8.71

Cavity marking	X (mm)	Y (mm)
Y	-7.96	+11.05
Z	-4.96	+12.70
a	-1.73	+11.53
b	+1.73	+11.53
c	+4.39	+9.22
d	+7.24	+7.19
e	+9.19	+4.45
f	+10.13	+1.17
g	+9.96	-2.24
h	+8.66	-5.41
i	+6.38	-7.98
j	+3.38	-9.63
k	0	-10.21
m	-3.38	-9.63
n	-6.38	-7.98
p	-8.66	-5.41
q	-9.96	-2.24
r	-10.13	+1.17
s	-9.19	+4.45
t	-7.24	+7.19
u	-4.39	+9.22

Cavity marking	X (mm)	Y (mm)
v	0	+8.59
w	+3.73	+5.66
x	+6.02	+3.10
y	+6.78	-0.25
z	+5.79	-3.53
AA	+3.33	-5.92
BB	0	-6.78
CC	-3.33	-5.92
DD	-5.79	-3.53
EE	-6.78	-0.25
FF	-6.02	+3.10
GG	-3.73	+5.66
HH	0	+5.08
JJ	+2.67	+2.39
KK	+3.43	-1.04
LL	0	-3.35
MM	-3.43	-1.04
NN	-2.67	+2.39
PP	0	0

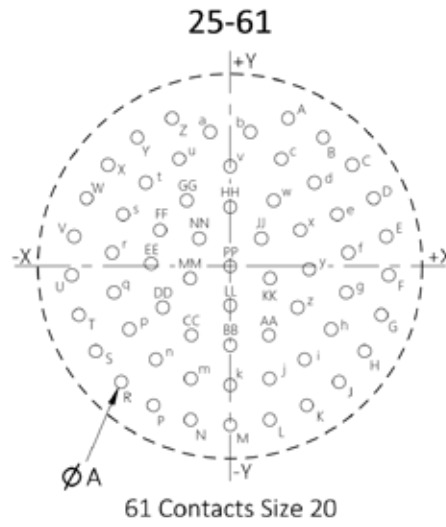

NOTES

Handwriting practice lines consisting of 24 horizontal dotted lines.

EXTENDED RANGE

REDUCED FLANGE



MAIN CHARACTERISTICS

- More density on panel 37% average footprint surface reduction
- More space inside the box: 36% average reduction of panel/PCB distance
- Lighter: 30% average lighter than standard 38999
- Derived from MIL-DTL-38999 series III version
- Mates with standard MIL-DTL-38999 series III plugs and caps
- Reduced flange receptacles are available in crimp version, with PC Tail contacts, as well as in stand off version
- For jam nut (TV07) configurations

SMALLER DIMENSIONS

Crimp Contacts	
38999 Series III Standard	38999 Series III Reduced Flange

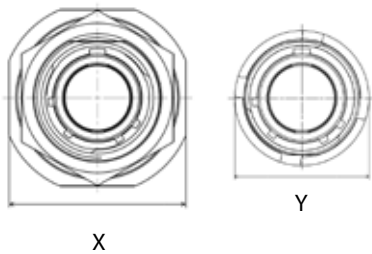

PC Tail Contacts	
38999 Series III PC Tail	38999 Series III Reduced Flange PC Tail

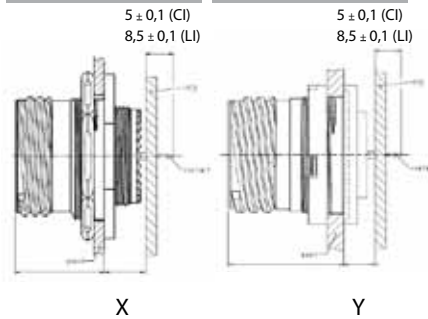

PC Tail Contacts & Stand Off	
38999 Series III Stand Off	38999 Series III Reduced Flange Stand Off

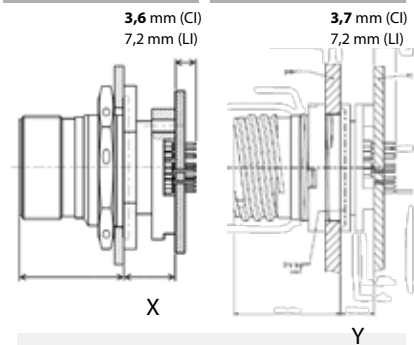

► Deviation: F312/F311* with safety castel nut

► Deviation: F059/F058* with safety castel nut

* with safety castel nut



FOOTPRINT AND WEIGHT SAVING

Sizes	Footprint Reduction (mm ²)
9	43%
11	46%
13	43%
15	36%
17	26%
19	37%
21	36%
23	34%
25	30%

Example of **Weight Reduction** :

38999 Series III stand off version: TV07WCI13-35P F459 = 31.46 g

38999 Series III Reduced flange stand off version : TV07WCI13-35P F259 = 19.49 g

> The #13 Reduced flange stand off version is **38 % lighter** than 38999 Series III standard stand off version.

TOOLS

Sizes	Tools PN
9	809681
11	809682
13	809683
15	809684
17	809685
19	809686
21	809687
23	809688
25	809689

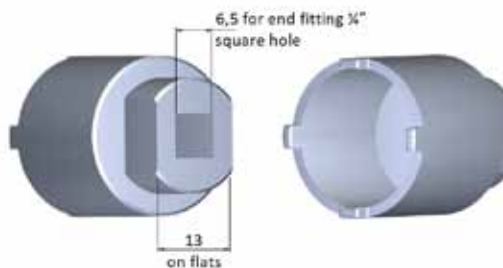

EXTENDED RANGE

STAND OFF RECEPTACLES

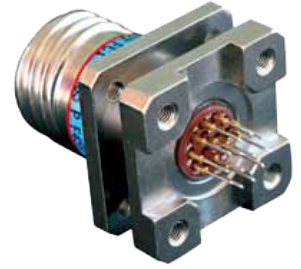

MAIN CHARACTERISTICS

- Receptacles with stand-off flange shells, for attachment to printed circuit boards.
- Tin plated contacts. Lead free versions available.
- Available in wall mount (TVP00) and jam nut (TV07) configurations.
- Prevent any mechanical stress on the contact tails.
- Provide grounding continuity between PCB and box.
- Increase reliability and resistance to shocks and vibrations
- For composite versions, please consult us.

Deviations :

- Lead Tinned Stand Off : F459
 - Silver Tinned Stand Off : F459LF
 - Silver Copper Tinned Stand Off : F459LFC
- For other versions, please consult us*

OVERALL DIMENSIONS

Jam nut receptacle (size 9 and 11)

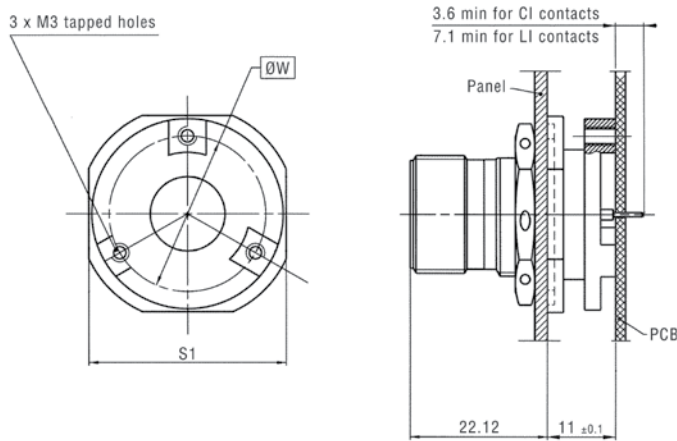

Square flange receptacle (size 9 to 25)

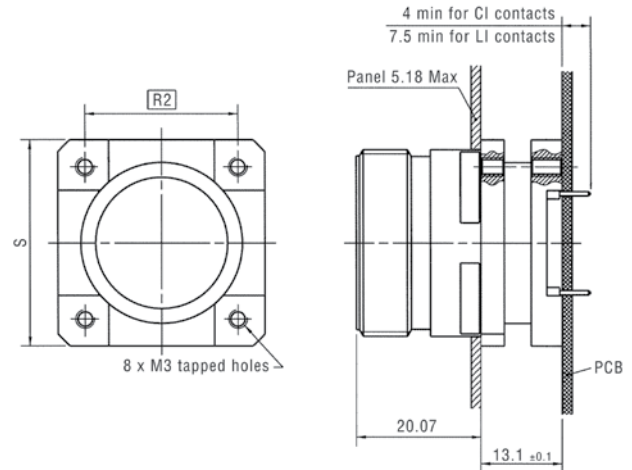

Jam nut receptacle (size 13 to 25)

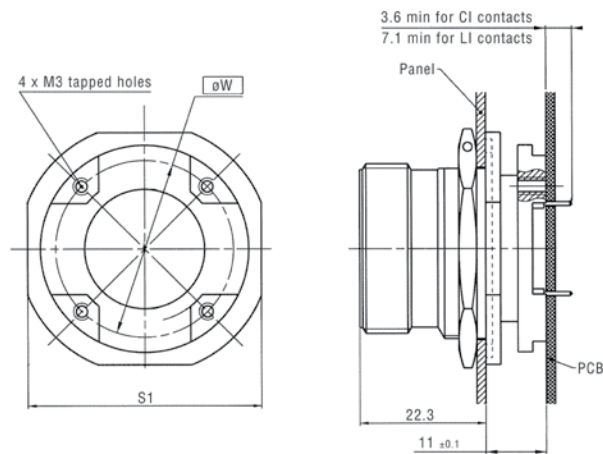

Shell Size	$S \pm 0.25$ (mm)	$R2$ (mm)	$S1 \pm 0.4$ (mm)	ϕW (mm)
9	23.83	16.00	27.0	20.50
11	26.19	18.26	31.8	25.20
13	28.58	20.62	34.9	25.25
15	30.96	23.01	38.1	28.42
17	33.32	26.10	41.3	31.42
19	36.53	27.24	46.0	35.03
21	39.67	29.36	49.2	37.82
23	42.88	31.75	52.4	41.12
25	46.02	34.93	55.6	44.30

Contact us for more detailed information.

For ordering informations, see section "Printed Circuit Board Connectors"

EXTENDED RANGE

TVS-Y / TVS-YN HERMETIC RECEPTACLES

PRESENTATION

TVS-Y and TVS-YN hermetic receptacles are dedicated to applications requiring low air leakage or high protection facing to contamination.



MAIN CHARACTERISTICS

- 9 shell sizes (stainless steel)
- Solder pin contacts in nickel alloy
- Contact plating in active zone: Gold
- Glass insert
- Air leakage < 1.10⁻⁷ cm³/s under 1 bar of differential pressure
- Passivation or nickel plating

OVERALL DIMENSIONS - HERMETIC VERSIONS

Square flange receptacle

TVPS02Y JD38999/21Y

TVPS02YN JD38999/21N

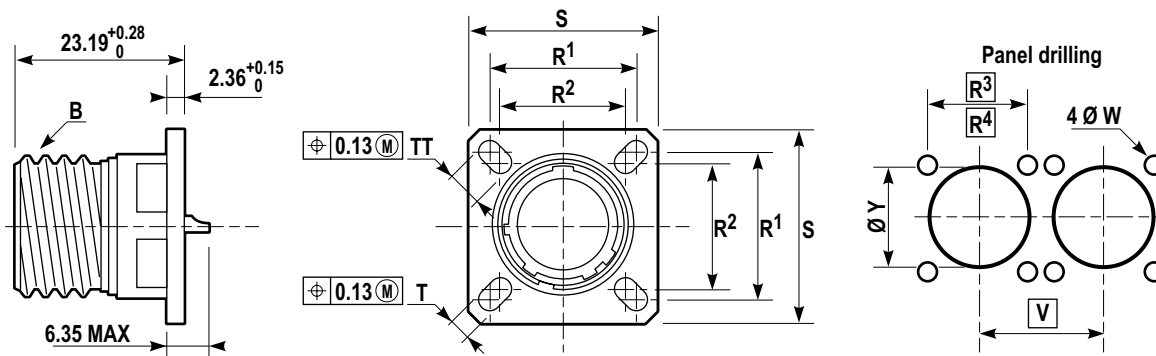

Shell size		B thread Class 2A 0.1P-0.3L-TS (inches)	R ¹ (mm)	R ² (mm)	S ±0.25 (mm)	T +0.20 -0.13 (mm)	TT +0.20 -0.13 (mm)	ØW +0 -0.25 (mm)	R ³ (mm)	R ⁴ (mm)	V Mini (mm)	ØY Mini (mm)
MIL-DTL-38999 Series III	Amphenol											
A	9	.6250	18.26	15.09	23.83	3.25	5.49	3.25	18.26	15.09	24.60	16.66
B	11	.7500	20.62	18.26	26.19	3.25	4.93	3.25	20.62	18.26	27.00	20.22
C	13	.8750	23.01	20.62	28.58	3.25	4.93	3.25	23.01	20.62	31.50	23.42
D	15	1.0000	24.61	23.01	30.96	3.25	4.39	3.25	24.61	23.01	34.50	26.59
E	17	1.1875	26.97	24.61	33.32	3.25	4.93	3.25	26.97	24.61	28.00	30.96
F	19	1.2500	29.36	26.97	36.53	3.25	4.93	3.25	29.36	26.97	40.50	32.94
G	21	1.3750	31.75	29.36	39.67	3.25	4.93	3.25	31.75	29.36	44.00	36.12
H	23	1.5000	34.93	31.75	42.88	3.91	6.15	3.81	34.93	31.75	47.00	39.29
J	25	1.6250	38.10	34.93	46.02	3.91	6.15	3.81	38.10	34.93	50.00	42.47

EXTENDED RANGE

TVS-Y / TVS-YN HERMETIC RECEPTACLES

Jam nut receptacle

TVS07Y JD38999/23Y
TVS07YN JD38999/23N

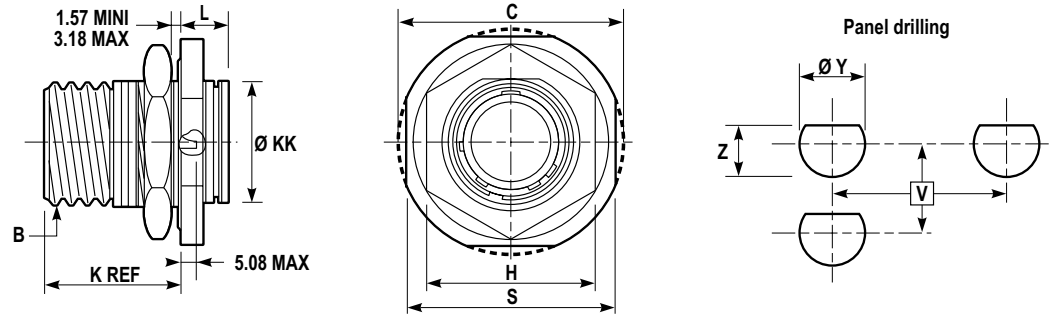

Shell size		B thread Class 2A 0.1P-0.3L-TS (inches)	C Maxi (mm)	H/plats +0.043 -0.41 (mm)	L Maxi (mm)	ØKK +0.28 0 (mm)	B ±0.25 (mm)	V Mini (mm)	ØY Mini (mm)	Z +0 -0.25 (mm)	Hex nut max torque value N.m
MIL-DTL-38999 Series III	Amphenol Socapex										
A	9	.6250	30.45	22.23	9.07	16.31	26.97	27.80	17.78	16.99	4.1
B	11	.7500	35.20	25.40	9.07	19.46	31.75	32.60	20.96	19.53	5.3
C	13	.8750	38.38	30.18	9.07	22.66	34.93	36.00	25.65	24.26	6.9
D	15	1.0000	41.55	33.32	9.07	25.86	38.10	39.60	28.83	27.53	8.6
E	17	1.1875	44.73	36.53	9.07	29.01	41.28	43.30	32.01	30.68	9.8
F	19	1.2500	49.50	39.67	9.68	32.21	46.02	47.00	35.18	33.86	10.9
G	21	1.3750	52.65	42.80	9.68	35.36	49.23	50.60	38.35	37.06	12.7
H	23	1.5000	65.85	46.02	9.68	38.56	52.37	54.20	41.53	40.01	13.8
J	25	1.6250	59.00	50.80	9.68	41.71	55.58	59.70	44.70	43.41	15

Solder mounting receptacle

TVSIY JD38999/25Y
TVSIYN JD38999/25N

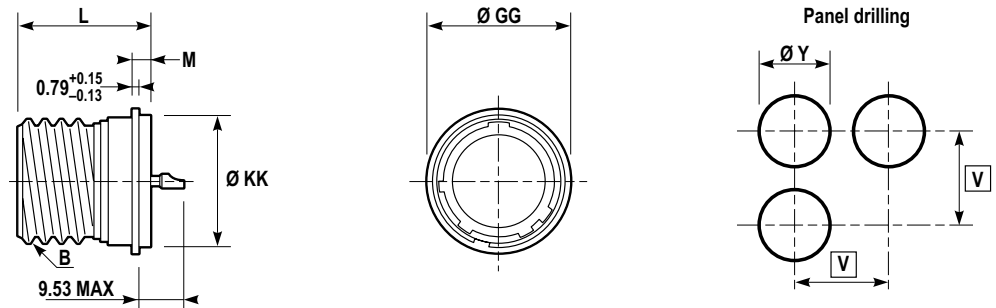

Shell size		B thread Class 2A 0.1P-0.3L-TS (inches)	ØGG +0.28 -0.25 (mm)	ØKK +0.03 -0.13 (mm)	L +0.28 -0 (mm)	M +0.15 -0.13 (mm)	V Mini (mm)	ØY Mini (mm)
MIL-DTL-38999 Series III	Amphenol							
A	9	.6250	19.05	17.07	20.47	3.18	24.60	17.60
B	11	.7500	21.44	19.84	20.47	3.18	27.00	20.40
C	13	.8750	24.61	23.01	20.47	3.18	31.50	23.50
D	15	1.0000	27.79	26.19	20.47	3.18	24.50	26.70
E	17	1.1875	30.94	29.36	20.47	3.18	38.00	29.90
F	19	1.2500	33.32	31.75	20.47	3.18	40.50	32.30
G	21	1.3750	36.53	34.93	20.47	3.18	44.00	35.50
H	23	1.5000	39.70	38.10	21.29	3.96	47.00	38.60
J	25	1.6250	42.88	41.28	21.29	3.96	50.00	41.80

POLARIZATION

MS Code	Socket contact Amphenol code	MS Code	Pin contact Amphenol code
SN	S (normal)	PN	P (normal)
SA	H	PA	G
SB	J	PB	I
SC	L	PC	K
SD	N	PD	M
SE	T	PE	R

EXTENDED RANGE

LANYARD RELEASE PLUGS (BREAKAWAY CONNECTORS)

PRESENTATION

Amphenol Breakaway Connectors provide unequalled performance in environments requiring instant disengagement. Designed to provide quick disconnect of a connector plug and receptacle with an axial pull on the lanyard, the "Breakaway" Fail Safe connector family offers a wide range of electrical and mechanical features:



- Compatible/intermateable with MIL-DTL-38999 series III receptacles
- Quick disconnect between plug and receptacle and damage free separation
- Up to 15° misalignment for instant desengagement
- Tread coupling (tri start connector)
- Other shell size and arrangements available in MIL-DTL-38999 standard lanyard versions
- 2 arrangements available for MIL-STD-1760 applications :

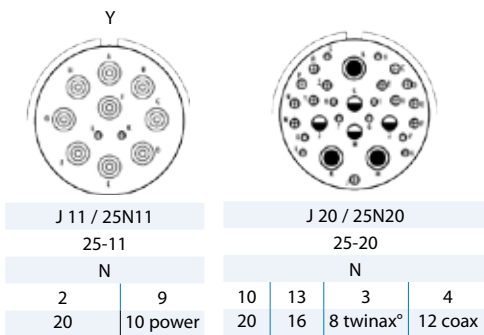

POLARIZATION

MS Code	Socket contact Amphenol code	MS Code	Pin contact Amphenol code
SN	S (normal)	PN	P (normal)
SA	H	PA	G
SB	J	PB	I
SC	L	PC	K
SD	N	PD	M
SE	T	PE	R

OVERALL DIMENSIONS

Lanyard release plugs - MIL-STD-1760

TVFBRW

JD38999/31W

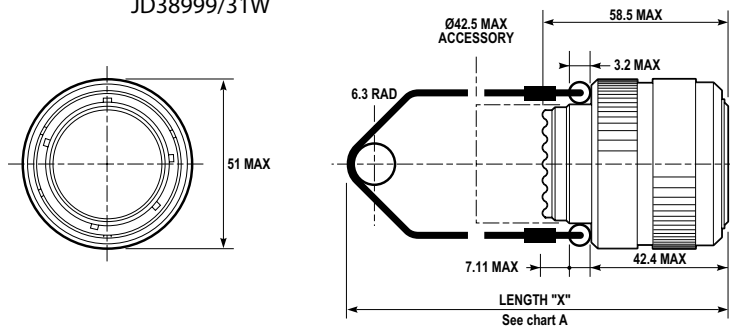

TABLE A

Length "X" MIL.STD 1760 coding	mm
A*	102
B*	115
C*	127
D	140
E	153
F	166
G	178
H	191
J	407
K	229
M	254
X	432

Other lengths are also available under TVFBRW proprietary designation. Consult us.

* for TV FBRW only

EXTENDED RANGE

LANYARD RELEASE PLUGS (BREAKAWAY CONNECTORS)

Lanyard release plugs

Standard version

(ordering information, see section "How to Order")

885565...P	JD38999/29W
915565...P	JD38999/29F
885565...S	JD38999/30W
915565...S	JD38999/30F

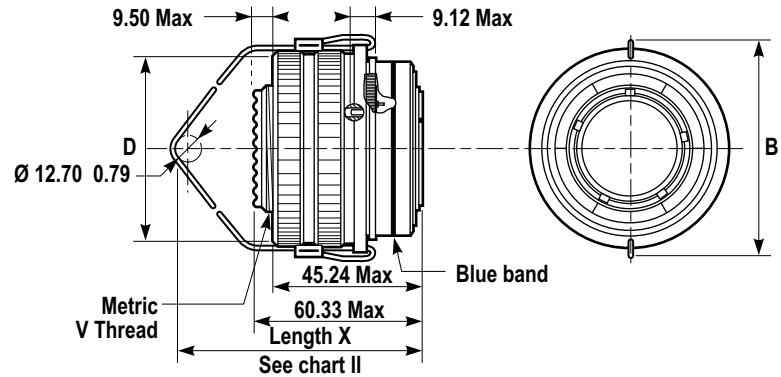

TABLE I

Arrangement code	Insert arrangement
04	11-04
06	11-35
07	11-98
08	11-02
10	13-4
11	13-08
13	13-98
14	13-35
18	15-5
19	15-19
20	15-35
21	15-97
22	15-18
23	15-15
27	17-06
28	17-08
29	17-26
30	17-35
31	17-99
37	19-11
38	19-28
39	19-32
40	19-35
47	21-11
48	21-16
49	21-35
50	21-41
51	21-39
57	23-21
58	23-35
59	23-53
60	23-55
61	23-54
66	25-19
67	25-29
68	25-35
69	25-43
70	25-61
71	25-04
72	25-24
73	25-46

TABLE II

Shell size		Metric Max	B Max (mm)	D Max (mm)
MIL-DTL-38999 Series III	Amphenol			
B	11	M15X1.0-6G	46.89	28.17
C	13	M18x1.0-6g	50.09	31.75
D	15	M22X1.0-6G	52.81	34.93
E	17	M25X1.0-6G	56.01	38.10
F	19	M28X1.0-6G	58.45	41.28
G	21	M31X1.0-6G	62.79	44.45
H	23	M34X1.0-6G	65.89	47.63
J	25	M37X1.0-6G	68.71	50.08

TABLE III

Length "X" (mm)	Code MS/Amphenol
102	A
115	B
127	C
140	D
153	E
166	F
178	G
191	H
203	I
216	J
229	K
242	L
254	M
267	N
280	P
293	R
305	S
318	T
331	U
356	V
381	W
407	X
432	Y
458	Z

EXTENDED RANGE THRU-BULKHEAD RECEPTACLES

TVB thru-bulkhead receptacles are used for the feed through of circuits on bulkheads or panels.



- Intermateable with MIL-DTL-38999 Series III connectors
- 9 shell sizes
- Interfacial seal on male side
- Olive drab cadmium or nickel plating
- Coding possibility

HOW TO ORDER

Thru-bulkhead Receptacles	TVB	W	15 35	PS	N	F467
Shell Material and finish						
W: Olive drab cadmium plated aluminium						
F: Electroless nickel plated aluminium						
B: Marine bronze						
ZN: Black Zinc Nickel						
Shell size and insert arrangements: see section "Insert Arrangements"						
Contact type						
PS: Pin & Socket						
Coding						
N, A, B, C, D, E						
Deviation						
F467: Drilled and tapped mounting holes (recommended)						

For further information, please consult us.

RANGE DERIVATED RECEPTACLES WITH ENHANCED SEALING

TV07 ETC receptacles with enhanced sealing are derived from the standard MIL-DTL-38999 Series III receptacles. The inserts have been modified to ensure an air leakage of $< 1.10^{-6} \text{cm}^3/\text{s}$ under 1 bar of differential pressure.



- Intermateable with MIL-DTL-38999 Series III connectors
- 9 shell sizes
- Solder or PCB pin contacts. Socket contacts available upon request

HOW TO ORDER

Series	TV	07	W	ET	C	15 35	P	A
Shell Type								
Jam nut receptacle: 175°C (O.D. cadmium): 07 200°C (nickel, bronze): S07								
Shell material, finish and contact type								
W: Olive drab cadmium plated aluminium								
F: Electroless nickel plated aluminium								
B: Marine bronze								
Z: Green zinc cobalt plated aluminium								
ZN: Black zinc nickel plated aluminium								
Enhanced sealing								
Contact termination								
C: Solder contacts								
CI: Standard PCB contacts								
LI: Long tail PCB contacts								
Shell size and insert arrangements: see section "Insert Arrangements"								
Contact type								
P: Pin								
Coding								
Blank for normal, A, B, C, D, E								

For further information, please consult us.

EXTENDED RANGE

INTEGRATED BACKSHELLS

MAIN CHARACTERISTICS

- All in one product
- Time saving during order and installation
- Space and weight saving
- Deviation : F472



Available on plugs and receptacles, these 2 in 1 connectors/band backshells provide a high EMI protection with a quick, easy and cost effective cabling process. They are low profile, with enhance sealing level and allow the use of macro and micro bands, as well as straight or right angle heat shrink moulded pieces. The design of the shells makes them compatible with over moulding process.

For further information, please consult us.

EXTENDED RANGE

MIL-DTL-38999 SERIES III OPTICAL CONNECTORS

TVOP

The TVOP connector is an optical version of the MIL-DTL-38999 series III connector, which uses standard 2.5 mm telecom optical termini in dedicated high precision inserts. It is designed to provide high level of performance and reliability, and cost effective solution for outdoor and indoor applications.



- 1 to 8 channels
- Available in multimode, singlemode PC and singlemode APC
- 0.5 dB typical Insertion Loss in multimode and singlemode

Insert arrangements



11-2



13-4

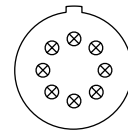

17-8

STARTOP

The STARTOP connector is made of standard MIL-DTL-38999 electrical connectors, using size 16 MIL-PRF-29504 optical termini. Hybrid versions (electrical and optical) are available, for further details please consult us.



- 1 to 8 channels
- Available in multimode
- 0.8 dB typical Insertion Loss

Insert arrangements



11-02

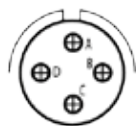

13-04

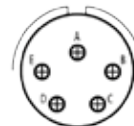

15-05

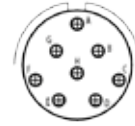

17-08

For further details, please consult the EWOC catalog (DOC-000503-ANG).

ACCESSORIES PROTECTIVE CAPS

STANDARD METALLIC CAPS

- For receptacles & plugs
- IP 68 (permanent sealing)

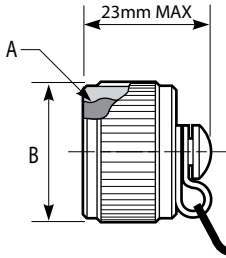

Protection cap for receptacles equipped with metallic chain, nylon cord or stainless steel rope

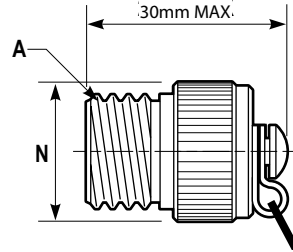

Protection cap for plugs equipped with metallic chain, nylon cord or stainless steel rope

Cap type	Metallic chain length (mm)	Nylon cord length (mm)	Stainless steel rope length (mm)
BEC/BER for receptacle	152	±105	127
BF for plug	127	160	127

Shell size		A thread 0.1P-0.3L-TS Class 2B (inches)	B Dia Max (mm)	C Dia Min (mm)	N Dia Max (mm)
MIL-DTL-38999 Series III	Amphenol				
A	9	.6250	22.23	17.86	22.73
B	11	.7500	25.40	21.44	25.40
C	13	.8750	28.58	25.81	29.74
D	15	1.0000	31.75	28.98	32.99
E	17	1.1875	36.53	32.16	36.47
F	19	1.2500	38.10	36.27	39.19
G	21	1.3750	41.28	38.51	42.42
H	23	1.5000	44.45	41.68	45.39
J	25	1.6250	47.63	44.86	48.62

ORDERING INFORMATION

Standard Metallic Caps	B	EC	N	TV	W	15
Protection cap type EC: For square flange receptacle ER: For jam nut receptacle F: For plug						
Wire type N: Nylon cord Blank for metallic chain R: Jacketed stainless steel rope RO: Jacketed stainless steel rope with washer end (only for plug)						
Connector type						
Finish B: Bronze ✓ F: Electroless nickel plated, aluminium version ✓ W: Olive drab cadmium plated aluminium version Z: Green zinc cobalt plated aluminium ✓ ZN: Black zinc Nickel aluminium from Amphenol Europe ✓						
Corresponding connector shell size: 09/11/13/15/17/19/21/23/25						

For stainless steel caps, please consult us

✓: RoHS compliant

ACCESSORIES

PROTECTIVE CAPS

RUBBER CAPS

NEW

- For receptacles
- IP67 (1m, 1 hour sealing)

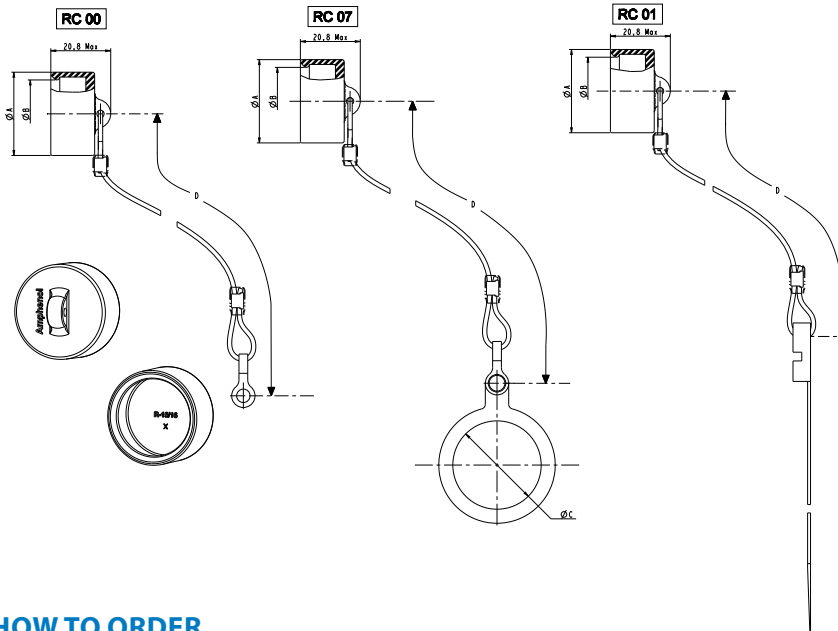

Sizes	ØA Max	ØB Max	ØC Max $+0,25$ 0	D Max
9	19,25	13,85	17,86	140
11	22,55	17,2	22,63	140
13	25,95	20,6	25,81	140
15	28,75	23,4	30,24	140

HOW TO ORDER

Cap Series	RC	00	N	TV	9
Protection cap type					
00: For square flange receptacle					
07: For jam nut receptacle					
01: For line receptacle					
Wire type					
N: Nylon cord					
Connector type					
Shell size:					
09/11/13/15/17/19					

ACCESSORIES

PROTECTIVE CAPS - TERMINATION TYPE

For both standard Metallic Caps & Rubber Caps

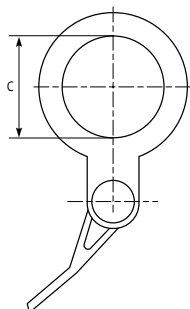

Termination of the chain, rope (RO type) or cord for jam nut receptacle protection caps

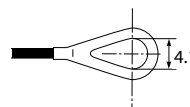

Termination of the cord or rope (R type) for square flange receptacle protection caps

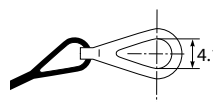

Termination of the chain for square flange receptacle and plug protection caps

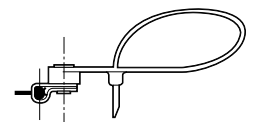

Termination of the cord for plugs protection caps

ACCESSORIES

BACKSHELLS



SHIELDING	
	<p>TV-35: BAND BACKSHELL FOR SHIELDING</p> <ul style="list-style-type: none"> • Full 360° shield termination • Available with different cabling chambers • Easy maintenance or repairability • Sealing ensured by straight or right angled heat-shrink molded piece • Right angle version: TV SBC
	<p>TV NSA: HIGH LEVEL OF EMI/RFI PROTECTION</p> <ul style="list-style-type: none"> • Electrical continuity between cable and connector by clamping the braid with a screwing system • Free inner ring to avoid twisting of the braid when screwing • Sealing ensured by straight or right angle heat-shrink molded piece
	<p>M85049/88: BAND LOCK ADAPTOR</p> <ul style="list-style-type: none"> • MIL standardized band backshell • Full 360° termination • Sealing ensured by straight or right angle heat-shrink molded piece • Right angle and 45° versions available
SEALING	
	<p>TV NSD: ADAPTER FOR HEAT-SHRINK MOLDED PIECE</p>
MECHANICAL RETENTION	
	<p>M85049/38 - M85049/38S: STRAIN RELIEF CLAMP</p> <ul style="list-style-type: none"> • MIL standardized strain relief clamp • Mechanical retention of the cable • Easy maintenance or repairability • Self locking option available
	<p>M85049/19: NON-ENVIRONMENTAL EMI/RFI BACKSHELL</p> <ul style="list-style-type: none"> • 360° screen termination • Strain relief cable holding mechanism

For more detailed information, consult our Backshell catalog (E118)

ACCESSORIES

OTHER ACCESSORIES

DUMMY RECEPTACLES

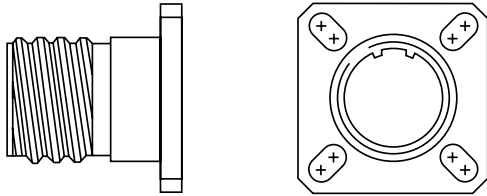

- Dummy receptacles match all plug types with any shell coding (N, A, B, C, D, E)
- Dimensions are identical to the front part of TVP00 receptacles
- A rubber washer ensures correct sealing of mated connectors
- Specific polarized versions are available on request

How to order - Amphenol designation

Dummy receptacle	SE	00	TV	W	11
Shell type					
00: derived from the TV square flange receptacle					
Series					
Finish					
W: Olive-drab cadmium plated					
F: Electroless nickel plated ✓					
B: Marine Bronze ✓					
ZN: Black Zinc Nickel plated ✓					
Shell size					
09/11/13/15/17/19/21/23/25					

✓: RoHS compliant

HOLDING SUPPORT EQUIPPED WITH OLIVE DRAB CADMIUM DUMMY RECEPTACLES REFERENCE: 809 931

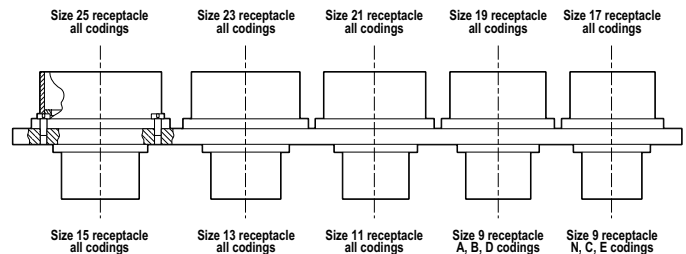

PLASTIC DUST CAPS

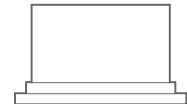

Shell size	Plastic dust caps for plug	Plastic dust caps for receptacles
9	606062	606061
11	805414	606062
13	606073	606063
15	606066	606064
17	606067	606065
19	606068	606066
21	606070	606067
23	606079	606068
25	606079	606069

ACCESSORIES

OTHER ACCESSORIES

CRIMP CONTACTS

	Contact size	Pin contacts		Socket contacts	
		Proprietary No	Military No	Proprietary No	Military No
Signal and Power	00	Refer to catalog contacts (DOC-000081-ANG)		Refer to catalog contacts (DOC-000081-ANG)	
	4	900007	-	900047	-
	8*	900197 900198**	-	900217	-
	12	900005	M39029/58-365	900045	M39029/56-353
	16	900000	M39029/58-364	900040	M39029/56-352
	20	900001	M39029/58-363	900041	M39029/56-351
	22D	900004	M39029/58-360	900044	M39029/56-348
	23	900049	M39029/18-177	900048	M39029/17-172

* Use with piggy back grommets is mandatory

** For arrangement 21-48 only

	Contact size	Pin contacts		Socket contacts		Cable Type
		Proprietary No	Military No	Proprietary No	Military No	
Coax	8*	900130	M39029/60-367	900140	M39029/59-366	M17/95-RG180
		900135	-	900145	-	M17/94-RG179 M17/113-RG316 M17/119-RG174
	12	900340	M39029/28-211	900350	M39029/75-416	M17/94-RG179 M17/113-RG316 M17/119-RG174
		900341	M39029/28-409	900351	M39029/75-417	M17/95-RG180 Raychem 9528 A1318
		900342***	-	900352**	-	M17/113-RG316
	16	900132	M39029/76-424	900142	M39029/77-428	M17/94-RG179 M17/113-RG316 M17/119-RG174 KX22A
900131		M39029/76-425	900141	M39029/77-429	M17/93-RG178 M17/169-00001	
Twinax	8*	074834	M39029/90-529	072453	M39029/91-530	M17/176-00002
Twinax	8*	600611	-	600614	-	M17/176-00002
Quadrax 100Ω	8	900330	-	900338	-	Tensolite NF24 Q100
Optical contact	16	-	M29504/4-4040	-	M29504/5-4046	50/125 & 62.5/125 fiber

* Use with piggy back grommets is mandatory

*** High performance size 12 coaxial contacts 50 ohms matched

For other cable types, please consult us

PIGGY BACK GROMMETS

The piggy back grommets insure back contact sealing when using size 8 power, coax, twinax or quadrax contacts. Quadrax contact part numbers always include piggy back grommets.

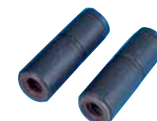

Type of contact	Cable OD (mm)	Proprietary No
Size 8 power	4.4 to 5.2	900471
Size 8 twinax and coax	3 to 4.4	900472
Size 8 twinax and coax	3 to 4.4	900476 ****

**** to use for arrangements 25-20, 19-17

ACCESSORIES

OTHER ACCESSORIES

SEALING PLUGS

To be mounted behind the crimp contacts

Contact size	Proprietary No	Military No
8 power	900024	-
12	900023	MS27488-12-2
16	900020	MS27488-16-2
20	900021	MS27488-20-2
22D	900022	MS27488-22-2
23	900022	MS27488-22-2

DUMMY CONTACTS

To be mounted instead of the contacts

Contact size	Dummy contact material	Proprietary No
4	White plastic	900329
8	Green plastic	900488
8	Brass + gold finish	900183
8	White plastic (recommended)	900029
12	Brass + gold finish	900025
12	White plastic	900486
16	Brass + gold finish	900028
16	Blue plastic	900026
20	Brass + gold finish	900332

Metal dummy contacts are recommended for applications requesting EMI protection.

STANDARD PC TAIL CONTACTS

	Contact size	Type	Pin contacts		Socket contacts	
			Tail dimension (mm)	Proprietary No	Tail dimension (mm)	Proprietary No
Signal	12	CI	5	900238	5	900403
	16	CI	5	900240	5	900263
		LI	8.5	900246	8.5	600526
	20	CI	5	900241	5	900251
		LI	8.5	900243	8.5	900252
	22D	CI	5	900245	5	900256
		LI	8.5	922389	8.5	922390
23	CI	5	900458	5	900459	
Coax	12	-	consult us	900489	-	-
		-	consult us	900409	-	-
	16	-	consult us	900184**	consult us	900405
Twinax	8	-	consult us	072265	-	-

** 900179 = 900184 + tin plating

Other PC tail lengths are available, please consult us.

ACCESSORIES

OTHER ACCESSORIES

REDUCING FERRULES

Reducing ferrules allow using cables with smaller diameters than specified in the table part electrical characteristics

Reducing ferrule No	Contact size	Wire Gauge	Pin contacts	Socket contacts
No reducing ferrule	8	8	900197 / 900198	900217
900154		10		
No reducing ferrule	12	12	900005	900045
900092		14		
		16		
900093		18		
		20		
No reducing ferrule	16	16	900000	900040
900091		18		
		20		
900090		22		
		24		
No reducing ferrule	20	20	900001	900041
900090		22		
		24		
900094		26		
900099	28	900004	900044	
No reducing ferrule	22D			34
				30
		22		
		24		
		26		
		28		

The sealing of mated connectors is only guaranteed for the minimum wire outside diameter given in the table part electrical characteristics.

1500 CYCLES CRIMP CONTACTS (FOR CTV ONLY)

	Contact size	Pin contacts		Socket contacts	
		Proprietary No	Military No	Proprietary No	Military No
Signal	20	900318	M39029/107-621	900323	M39029/106-615
	22D	900317	M39029/107-620	900322	M39029/106-614
	16	900319	M39029/107-622	900324	M39029/106-616

ACCESSORIES

APPLICATION TOOLS

CRIMPING TOOLS



Contact size	Contact type	Contact part number		Crimping tool		Positioner	
		Proprietary No	Military No	Proprietary No	Military No	Proprietary No	Military No
00		Refer to catalog contacts (DOC-000081-ANG)					
4	P	900007	-	809947	-	809948	-
	S	900047	-	809947	-	809948	-
8 Coax		Inner pin & socket		809 801	M22520/2-01	-	M22520/2-31
		Outer pin & socket		809 914	M22520/5-01	809 915	M22520/5-41
8 Power	P	900 197	-	809 872	-	809 873	-
	P	900 198	-	809 872	-	809 873	-
	S	900 217	-	809 872	-	809 873	-
12 Coax		Inner pin & socket		809 801	M22520/2-01	809 932	M22520/2-34
		Outer pin & socket		809 926	M22520/31-01	809 927	M22520/31-02
12	P	900 005	M39029/58-365	809 857	M22520/1-01	809 858	M22520/1-04
	S	900 045	M39029/56-353	809 857	M22520/1-01	809 858	M22520/1-04
16 Coax		Inner pin & socket		809 801	M22520/2-01	809 862	M22520/2-35
		Outer pin & socket		809 863	M22520/4-01	809 864	M22520/4-02
16	P	900 000	M39029/58-364	809 857	M22520/1-01	809 858	M22520/1-04
	S	900 040	M39029/56-352	809 857	M22520/1-01	809 858	M22520/1-04
20	P	900 001	M39029/58-363	809 857	M22520/1-01	809 858	M22520/1-04
				809 801	M22520/2-01	809 826	M22520/2-10
	S	900 041	M39029/56-351	809 857	M22520/1-01	809 858	M22520/1-04
22D				809 801	M22520/2-01	809 826	M22520/2-10
	P	900 004	M39029/58-360	809 801	M22520/2-01	809 810	M22520/2-09
	S	900 044	M39029/56-348	809 801	M22520/2-01	809 835	M22520/2-07
23	P	900 049	M39029/18-177	809801	M22520/2-01	809 691	M22520/2-13
	S	900 048	M39029/17-172	809801	M22520/2-01	809 692	M22520/2-16

INSERTION AND REMOVAL TOOLS

Plastic tools



Contact size	Insertion tool		Removal tool		Colour	
	Proprietary No	Military No	Proprietary No	Military No	Insertion	Extraction
8 Power/coax	*	*	-	M81969/14-12	-	green
12	809 859	M81969/14-04	809 859	M81969/14-04	yellow	white
16	809 855	M81969/14-03	809 855	M81969/14-03	blue	white
20	809 854	M81969/14-10	809 854	M81969/14-10	red	orange
22D	809 856	M81969/14-01	809 856	M81969/14-01	green	white

* Manual insertion

Metallic tools



Contact size	Straight type		Angle type			
	Insertion tools Proprietary No	Removal tools Proprietary No	Insertion tools		Removal tools	
			Proprietary No	Military No	Proprietary No	Military No
4	*	809943	-	-	-	-
8 Power/coax	-	809961	*	*	809 845	M81969/8-14
12	-	-	809 838	M81969/8-09	809 839	M81969/8-10
16	809 816	809 846	809 812	M81969/8-07	809 820	M81969/8-08
20	809 817	809 847	809 813	M81969/8-05	809 821	M81969/8-06
22D	809 819	809 849	809 815	M81969/8-01	809 823	M81969/8-02
23	810 010	810 010	-	-	-	-

* Manual insertion

HOW TO ORDER

STANDARD VERSIONS

AMPHENOL DESIGNATION

Series	TV	P00	R	Q	W	17-75	P	A	-	-
TV: Metallic shell										
CTV: Composite shell										
Shell type										
P00: Square flange receptacle: 175°C (O.D. cadmium, g.zinc cobalt, ni-PTFE, b.zinc nickel)										
PS00: Square flange receptacle: 200°C *** (nickel, s.steel, bronze)										
07: Jam nut receptacle: 175°C (O.D. cadmium, g.zinc cobalt, ni-PTFE, b.zinc nickel)										
S07: Jam nut receptacle: 200°C *** (nickel, s.steel, bronze)										
06: Straight plug: 175°C (O.D. cadmium, g.zinc cobalt, ni-PTFE, b.zinc nickel)										
S06: Straight plug: 200°C *** (nickel, s.steel, bronze)										
01: In line receptacle 175°C (O.D. cadmium, g.zinc cobalt, ni-PTFE, b.zinc nickel)										
S01: In line receptacles 200°C *** (nickel, s.steel, bronze)										
02: P00 without rear threat (no poss. for backshell) 175°C (O.D. cadmium, g.zinc cobalt, ni-PTFE, b.zinc nickel)										
S02: PS00 without rear threat (no poss. for backshell) 200°C *** (nickel, s.steel, bronze)										
Contact type										
R: Crimp contacts (or connector delivered without contact) Omit for PC tail contacts, Durmalon plating and black zinc nickel plating										
Ground Plane receptacle and Quadrax contact options										
G: conductive insert										
Q: insert compatible with quadrax or differential twinax contacts **										
GQ: conductive insert compatible with quadrax or differential twinax contacts Omit for standard receptacle (without conductive insert) and insert without quadrax contact										
Class										
W: Olive Drab Cadmium plating (on aluminium or composite)										
F: Nickel Plating (on aluminium or composite) ✓										
K: Passivated Stainless Steel ✓										
S: Nickel plated Stainless Steel ✓										
B: Marine Bronze (copper aluminium alloy) ✓										
DT: Durmalon plating (Nickel - PTFE) ✓										
Z: Green zinc Cobalt plated aluminium ✓										
ZN: Black Zinc Nickel plated aluminium ✓										
PC Tail Contacts										
Omit for crimp contacts										
CI: standard PCB contacts										
LI: long tail PCB contacts										
Shell size and Contact arrangement *** See section "Insert Arrangements"										
Contact type										
P: Pin (500 cycles)										
S: Socket (500 cycles)										
H: Pin (1500 cycles - CTV only)										
J: Socket (1500 cycles - CTV only)										
Polarization Blank for normal or A, B, C, D, E . See coding system, section "Insert Arrangements"; sub-section "coding polarization"										
Contacts Omit for connectors delivered with contacts										
LC: Connector delivered without contacts										
Deviation										
F404 / F404LF / F404LFC: Tinned PCB contacts (lead tinned / silver tinned / silver-copper tinned)										
F485 (for TVS06 RB only): Coupling nut conforms to CECC75 - 201 - 002A (for arctic gloves)										
F459 / F459LF / F459LFC: stand-off receptacle (lead tinned / silver tinned / silver-copper tinned)										
F472 Integrated backshells										
For other deviations (FXXX), please <i>consult us</i> .										

** For Quadrax or dif. Twinax compatible inserts, please omit the "S" corresponding to 200°C compatibility when applicable, in the P/N. Ex: CTV07RQQF17 52PLC
For other arrangements, shell, coding or deviation, please consult us.

***For high-density contact arrangement, please omit the « S » corresponding to 200°C compatibility in the P/N. High-density inserts are +175°C maxi compatible. Ex: TVP 00 RF 09 09 S

✓: RoHS compliant

HOW TO ORDER

STANDARD VERSIONS

MILITARY DESIGNATION (CRIMP CONTACTS ONLY)

Series	JD38999/	20	F	H	53	P	A
Shell type							
20: Square flange receptacle							
24: Jam nut receptacle							
26: Straight plug							
Shell material and finish							
<u>Composite</u>							
J: Olive drab cadmium plated 175°C							
M: Electroless nickel plated 200°C ✓							
<u>Aluminium</u>							
W: Olive drab cadmium plated 175°C							
F: Electroless nickel plated 200°C ✓							
T: Nickel PTFE plated 175°C ✓							
Z: Black Zinc Nickel plated aluminium 175°C ✓							
<u>Stainless steel</u>							
K: Passivated 200°C, firewall capability ✓							
S: Nickel plated 200°C, firewall capability ✓							
Shell size							
A B C D E F G H J MIL							
09 11 13 15 17 19 21 23 25 Amphenol							
Contact arrangement							
See section "Insert Arrangements"							
Contact and connector type							
A: Without pin contact							
B: Without socket contact							
P: With pin contacts							
S: With socket contacts							
H: With 1500 cycles pin contacts (only valid for composite)							
J: With 1500 cycles socket contacts (only valid for composite)							
Polarization							
N for normal or A, B, C, D, E. See coding system, section "Insert Arrangements"							

✓: RoHS compliant

EN3645 (EUROPEAN NORM ORDERING INFORMATION, ASD-STAN) - (CRIMP CONTACTS ONLY)

Standard number	EN3645	F	0	G	N	16	A	N
Class:								
W: Crimp version, Aluminum Olive drab cadmium plated, 175°C								
F: Crimp version, Aluminum Nickel plated, 200°C ✓								
J: Crimp version, Composite material Olive Drab cadmium plated, 175°C								
M: Crimp version, Composite material Nickel plated, 200°C ✓								
K: Crimp version, Passivated Stainless Steel, 200°C ✓								
Shell style:								
0: Square flange receptacle								
7: Jam Nut Receptacle								
6: Plug								
Shell size code:								
A for 09, B for 11, C for 13, D for 15, E for 17, F for 19, G for 21, H for 23, J for 25								
Insert type:								
N: Standard								
G: Grounded cavities								
Q: Quadrax insert, grounded								
L: Quadrax insert, non grounded								
R: Power insert								
Contact arrangement according to EN3645-002:								
See section "Insert Arrangements"								
Contact code:								
M: with Pin contacts			F: with Socket contacts			Coax, twinax, quadrax contacts are not supplied with the connector		
A: without Pin contacts			B: without Socket contacts					
Polarization (Key Ways rotation):								
N, A, B, C, D, E. See coding system, section "Inser Arrangements"								

HOW TO ORDER

HERMETIC VERSIONS

AMPHENOL DESIGNATION

Series	TV	SI	YN	11	35	P	-
Shell type							
PS02: Square flange receptacle							
S07: Jam nut receptacle							
SI: Solder mounting receptacle							
Shell material and finish							
Y: Stainless steel passivated ✓							
YN: Stainless steel nickel plated ✓							
Shell size:							
09/11/13/15/17/19/21/23/25							
Contact arrangement							
See section "Insert Arrangements", marked with "Y"							
Contact type							
P: Pin							
Polarization							
Blank for normal or A, B, C, D, E. See coding system, section "Insert Arrangements"							

MILITARY DESIGNATION

Connector type	JD38999/	25	N	B	35	P	N
Shell type							
21: Square flange receptacle							
23: Jam nut receptacle							
25: Solder mounting receptacle							
Shell material and finish							
Y: Stainless steel passivated ✓							
N: Stainless steel nickel plated ✓							
Shell size							
A B C D E F G H J MIL							
09 11 13 15 17 19 21 23 25 Amphenol							
Contact arrangement							
See section "Insert Arrangements", marked with "Y"							
Contact type							
P: Pin							
Polarization							
N for normal or A, B, C, D, E. See coding system, section "Insert Arrangements"							

✓: RoHS compliant

HOW TO ORDER

LANYARD RELEASE PLUGS - STANDARD VERSIONS

AMPHENOL DESIGNATION

Shell finish 88: Olive-drab cadmium plated 91: Nickel plated ✓	88	5565	20	K	P
Connector type					
Shell size and arrangement code See table I, section "Range Derivated", Sub-section "Lanyard Release Plugs" Others, please consult us					
Lanyard length A to Z code (see table III, section "Range Derivated", Sub-section "Lanyard Release Plugs")					
Contact type and polarization See chart below and coding, section "Insert Arrangement"					

MILITARY DESIGNATION

Connector type JD38999/ 29: Plug with pin contacts 30: Plug with socket contacts	JD38999/ 29	W	D	35	E	N
Shell finish W: Olive drab cadmium plated F: Nickel plated ✓						
Shell size A* B C D E F G H J MIL 09* 11 13 15 17 19 21 23 25 Amphenol * Please consult us						
Contact arrangement See table I, section "Range Derivated", Sub-section "Lanyard Release Plugs"						
Lanyard length A to Z code (see table III, section "Range Derivated", Sub-section "Lanyard Release Plugs")						
Polarization N for normal or A, B, C, D, E. See coding, section "Insert arrangement"						

✓: RoHS compliant

HOW TO ORDER

LANYARD RELEASE PLUGS - COMPATIBLE WITH MIL-STD-1760 APPLICATIONS

AMPHENOL DESIGNATION

Series	TV	FB	RW	25-11	P	E
FB: MIL-STD-1760 lanyard release plug						
RW: Olive drab cadmium plated						
Arrangement 25-11, 25-20: see section "Insert Arrangements"						
Contact type and polarization G: 25-11 arrangement, pin contacts only P: 25-20 arrangement, pin contacts only						
Lanyard length Other lengths are available upon request. See table A, section "Range Derivated", sub-section "Lanyard Release Plugs"						

MILITARY DESIGNATION

Series	JD38999/	31	W	E	11	N	1
Shell and contact type 31: Plug with pin contacts, per MIL-STD-1760							
Shell finish W: Olive drab cadmium plated 175°C							
Lanyard length. See table A, section "Range Derivated", sub-section "Lanyard Release Plugs"							
Contact arrangement 11: 25-11 arrangement 20: 25-20 arrangement							
Polarization N for 25-20 arrangement. See section "Insert Arrangement" A for 25-11 arrangement.							
Plug locking ring type 1: Ø 51mm (low profile) 2: Ø 68mm (please consult us)							

For MIL-STD-1760 Type II connectors, please consult us.

NOTES

Area with horizontal dotted lines for taking notes.

HOW TO ORDER

CROSS REFERENCES

Shell material	MIL-DTL-38999 Series III	EN 3645	AMPHENOL
Composite shell	JD38999/20J X XX A °	EN3645 J0 X N XX A °	CTVP00RW ■■■## P ^ LC
			CTVP00WCI ■■■## P ^ LC
		EN3645 J0 X L XX A °	CTVP00RQW ■■■## P ^ LC
		EN3645 J0 X Q XX A °	CTVP00RGQW ■■■## P ^ LC
	JD38999/20M X XX A °	EN3645 M0 X N XX A °	CTVPS00RF ■■■## P ^ LC
			CTVPS00FCI ■■■## P ^ LC
		EN3645 M0 X L XX A °	CTVP00RQF ■■■## P ^ LC
		EN3645 M0 X Q XX A °	CTVP00RGQF ■■■## P ^ LC
	JD38999/24J X XX A °	EN3645 J7 X N XX A °	CTV07RW ■■■## P ^ LC
			CTV07WCI ■■■## P ^ LC
		EN3645 J7 X L XX A °	CTV07RQW ■■■## P ^ LC
		EN3645 J7 X Q XX A °	CTV07RGQW ■■■## P ^ LC
	JD38999/24M X XX A °	EN3645 M7 X N XX A °	CTVS07RF ■■■## P ^ LC
			CTVS07FCI ■■■## P ^ LC
		EN3645 M7 X L XX A °	CTV07RQF ■■■## P ^ LC
		EN3645 M7 X Q XX A °	CTV07RGQF ■■■## P ^ LC
	JD38999/26J X XX A °	EN3645 J6 X N XX A °	CTV06RW ■■■## P ^ LC
		EN3645 J6 X L XX A °	CTV06RQW ■■■## P ^ LC
JD38999/26M X XX A °	EN3645 M6 X N XX A °	CTVS06RF ■■■## P ^ LC	
	EN3645 M6 X L XX A °	CTV06RQF ■■■## P ^ LC	
Aluminium shell	JD38999/20W X XX A °	EN3645 W0 X N XX A °	TVP00RW ■■■## P ^ LC
			TVP00WCI ■■■## P ^ LC
		EN3645 W0 X L XX A °	TVP00RQW ■■■## P ^ LC
	JD38999/20Z X XX A °		TVP00ZN ■■■## P ^ LC
			TVP00ZNCI ■■■## P ^ LC
			TVP00RQZN ■■■## P ^ LC
		EN3645 W0 X Q XX A °	TVP00RGQZN ■■■## P ^ LC
	JD38999/20F X XX A °	EN3645 F0 X N XX A °	TVP00RGQW ■■■## P ^ LC
			TVPS00RF ■■■## P ^ LC
		EN3645 F0 X L XX A °	TVPS00FCI ■■■## P ^ LC
		EN3645 F0 X Q XX A °	TVP00RQF ■■■## P ^ LC
	JD38999/24W X XX A °	EN3645 W7 X N XX A °	TVP00RGQF ■■■## P ^ LC
			TV07RW ■■■## P ^ LC
			TV07WCI ■■■## P ^ LC
		EN3645 W7 X L XX A °	TV07RQW ■■■## P ^ LC
		EN3645 W7 X Q XX A °	TV07RGQW ■■■## P ^ LC
	JD38999/24Z X XX A °		TV07ZN ■■■## P ^ LC
			TV07ZNCI ■■■## P ^ LC
			TV07RQZN ■■■## P ^ LC
			TV07RGQZN ■■■## P ^ LC
	JD38999/24F X XX A °	EN3645 F7 X N XX A °	TVS07RF ■■■## P ^ LC
			TVS07FCI ■■■## P ^ LC
		EN3645 F7 X L XX A °	TV07RQF ■■■## P ^ LC
		EN3645 F7 X Q XX A °	TV07RGQF ■■■## P ^ LC
JD38999/26W X XX A °	EN3645 W6 X N XX A °	TV06RW ■■■## P ^ LC	
	EN3645 W6 X L XX A °	TV06RQW ■■■## P ^ LC	
JD38999/26Z X XX A °		TV06ZN ■■■## P ^ LC	
		TV06RQZN ■■■## P ^ LC	
JD38999/26F X XX A °	EN3645 F6 X N XX A °	TVS06RF ■■■## P ^ LC	
	EN3645 F6 X L XX A °	TV06RQF ■■■## P ^ LC	
Stainless Steel shell	JD38999/20K X XX A °	EN3645 K0 X N XX A °	TVPS00RK ■■■## P ^ LC
			TVPS00KCI ■■■## P ^ LC
	JD38999/20S X XX A °		TVPS00RS ■■■## P ^ LC
			TVPS00SCI ■■■## P ^ LC
	JD38999/24K X XX A °	EN3645 K7 X N XX A °	TVS07RK ■■■## P ^ LC
			TVS07KCI ■■■## P ^ LC
	JD38999/24S X XX A °		TVS07RS ■■■## P ^ LC
			TVS07SCI ■■■## P ^ LC
JD38999/26K X XX A °	EN3645 K6 X N XX A °	TVS06RK ■■■## P ^ LC	
JD38999/26S X XX A °		TVS06RS ■■■## P ^ LC	
Hermetic receptacles	JD38999/21Y X XX P °	EN3645 Y0 X N XX M °	TVPS02Y ■■■## P ^
	JD38999/21N X XX P °		TVPS02YN ■■■## P ^
	JD38999/23Y X XX P °	EN3645 Y7 X N XX M °	TVS07Y ■■■## P ^
	JD38999/23N X XX P °		TVS07YN ■■■## P ^
	JD38999/25Y X XX P °	EN3645 Y1 X N XX M °	TVSIY ■■■## P ^
	JD38999/25N X XX P °		TVSIYN ■■■## P ^
Dust caps	JD38999/32W X R	EN3645 W4 X 0	BF R TV W ■■■
	JD38999/32W X N	EN3645 W4 X 7	BF RO TV W ■■■
	JD38999/33W X R	EN3645 W3 X 0	BEC R TV W ■■■
	JD38999/33W X N	EN3645 W3 X 7	BER R TV W ■■■
Dummy receptacle		EN3645 W5 X	SE00 TV W ■■■

As example, male version without contact (except for bronze and hermetic male versions with contacts).

Caption	MIL-DTL-38999 Series III P/N	EN3645	AMPHENOL P/N
Shell size	X	X	■■■
Insert arrangement	XX	XX	##
Polarization, rotation of secondary keyways	°	°	^

NOTES

Area with horizontal dotted lines for taking notes.

Amphenol Socapex

948, promenade de l'Arve BP29
74311 Thyez Cedex - France
Phone: +33 (0)4 50 89 28 00
contact@amphenol-socapex.fr
www.amphenol-socapex.com

 [www.twitter.com/AmphenolSocapex](https://twitter.com/AmphenolSocapex)
 www.linkedin.com/company/amphenol-socapex

Amphenol Sales contacts in Europe

Amphenol Air LB

2 rue Clément Ader, ZAC de WE
08110 Carignan - FRANCE
Phone: +33 (0)3 24 22 78 49

Amphenol SEFEE

Z.I. des Cazes - BP 243
12402 Saint-Affrique Cedex - France
Phone: +33 5 65 98 11 00

Amphenol AIR LB GmbH

Am Kleinbahnhof 4
66740 Saarlouis - GERMANY
Phone: +49 6831 981 00

Amphenol LIMITED

Thanet Way, Whitstable
Kent, CT53JF - UNITED KINGDOM
Phone: +44 (0) 1227 773200

Amphenol INVOTEC

Invotec Circuits Tamworth Limited
Hedging Lane, Dosthill,
Tamworth, B77 5HH - UNITED KINGDOM
Phone: +44 (0) 1827 263250

Amphenol IONIX

Greenfold Way - Leigh
Lancashire, WN7 3XJ - UNITED KINGDOM
Phone: +44 1942 685200

Amphenol MARTEC LIMITED

St Augustines Business Park, Swalecliffe,
Whitstable
Kent, CT5 2QJ - UNITED KINGDOM
Phone: +44 (0) 1227 793733

Amphenol ITALY

Via Barbaiana n.5
20020 Lainate - Milano - ITALY
Phone: +39 293 254 214

Amphenol IBERICA

Edificio Burgosal, Oficina nr 55 - Comunidad de
Madrid, 35-bis Las Rozas SPAIN
Phone: +34 629 054629

Amphenol AUSTRIA & CEE

Wiener Gasse 68
2380 Perchtoldsdorf - AUSTRIA
Phone: +43 699 10396071

Amphenol POLAND

Lwowska 8/16,
53-516 Wroclaw - POLAND
Phone: +48 513017157

Amphenol SWITZERLAND

Phone: +43 699 10396071

Amphenol SOUTH CENTER

Slovenia, Serbia, Montenegro, Yugoslavia,
Greece, Bulgaria
Phone: +39 02 93254208
Phone: +39 02 93254210

Amphenol NORDIC

Phone: +46 70 2129200 (Mil/Aero)
+46 76 7909560 (Industrial)

Amphenol BENELUX

Zadkinestraat 26
Almere, 1328 NN - THE NETHERLANDS
Phone: +31 651 296835

Amphenol SCANDINAVIA AB

Ångsullsvägen 7-5
187 51 Täby - SWEDEN
Phone: +46 70 21 29200

Amphenol Sales contacts in Asia

Amphenol DAESHIN

558 SongNae-Dong SoSa-Gu, Bucheon-city, Kyunggi-Do
Korea 420-130
Phone: +81-32 610 3800

Amphenol EAST ASIA LTD.

159 Kampong Ampat, #04-01/04
KA Place
Singapore 368328
Phone: +656549-6537/ +656294-2128

Amphenol INTERCONNECT INDIA PRIVATE LIMITED

105 Bhosari Industrial Area - Pune 411 026 - India
Phone: +91 20 3068 8304

Amphenol PCD CO. LTD

Building 21, 1st Liao Keng Industrial Zone, Shi Yan Street
Bao An District, Shenzhen 518108 - China
Phone: +86 755 8173 8000/8286

Amphenol JAPAN

471-1, Deba, Ritto-City, Shiga 520 3041 - Japan
Phone: +81 77 553 8501

Amphenol Sales contacts in North America

Amphenol PCD

72 Cherry Hill Drive - Beverly, MA. 01915 - USA
Phone: +1 978-624-3400

Amphenol FIBER SYSTEMS INT.

1300 Central Expwy N, Suite 100
Allen, TX 75013 - USA
Phone: +1 214-547-2400

Amphenol AEROSPACE OPERATIONS

40-60 Delaware street - Sidney, NY 13838-1395
- USA
Phone: +1 800-678-0141

Amphenol PRINTED CIRCUIT BOARD TECHNOLOGY

91 Northeastern Boulevard
Nashua, New Hampshire 03062 - USA
Phone: +1 603-324-4500

SV MICROWAVE

2400 Centrepark West Dr.
West Palm Beach, FL 33409 - USA
Phone: +1 561-840-1800

Amphenol ADVANCED SENSORS

967 Windfall Road
St. Mary's, PA 15857-3333 - USA
Phone: +1 814-834-9140

TIMES MICROWAVE SYSTEMS

358 Hall Avenue
Wallington, CT 06492 - USA
Phone: +1 800-867-2629

Amphenol GRIFFITH ENTERPRISES

6000 E Coury Drive
Cottonwood, AZ 86326-9202 - USA
Phone: +1 928-634-3685

Amphenol NEXUSTECHNOLOGIES, INC

50 Sunnyside Ave., Stamford,
CT 06902 - USA
Phone: +1 203-327-7300

Amphenol BORISCH TECHNOLOGIES

4511 East Paris
Grand Rapids, MI 49512 - USA
Phone: +1 616 554 9820

Amphenol CANADA CORPORATION

605 Milner avenue - M1B 5X6 - Toronto, Ontario -
CANADA
Phone: +1 416 291 4401

Amphenol Sales contacts in Other Areas

Amphenol ARGENTINA

Av. Callao 930 2do piso Oficina B "Plaza" C1023 - AAP
Buenos Aires - ARGENTINA
Phone: +54 11 4815-6886

Amphenol AUSTRALIA PTY LIMITED

2 Fiveways Blvd., Keysborough - Melbourne
Victoria 3173 - AUSTRALIA
Phone: +61 3 8796-8888

Amphenol DO BRAZIL

Rua Diogo Moreira, 132, 20 andar, rooms 2001-2-3
CEP: 05423-010 Sao Paulo SP - BRAZIL
Phone: +55 11 3815-1003

Bar-Tec Ltd., ISRAEL

3 Hagavish Street, Kfir-Barkan Bldg. East Industrial
Zone - Kfar-Sava, 44102 - ISRAEL
Phone: +972 9 764 4100

Amphenol MEXICO

Prolongacion Reforma 61-6 B2
Col Paseo de las Lomas - C.P. 013130 - MEXICO
Phone: +52 55 5258-9984

Amphenol AFRICA

30 Impala Rd,
Sandton 2146 - SOUTH AFRICA
Phone: +27 82 410 5179

Amphenol TURKEY

Sun Plaza 15 Kat: 15 Maslak Hah. Bilim Sok. No.5
Sisli/Istanbul, 34398 - TURKEY
Phone: +90 212 367 9220

Amphenol

The information given in this document are **as a guideline only**.
We reserve the right to **modify our products** in any way we deem necessary.
Any duplication is **prohibited**, unless approved in writing.
This catalog uses paper from managed forests, PEFC & FSC labels, and is printed by a printer certified "Imprim'Vert®".

Your local Contact:



For more information, please visit our website:
www.amphenol-socapex.com

Mouser Electronics

Authorized Distributor

Click to View Pricing, Inventory, Delivery & Lifecycle Information:

Amphenol:

[TVP00WCI0935P](#) [TVP00WCI1198P](#) [TVP00WCI1335PF459](#) [TVP00WCI1335P](#) [TVP00WCI1135P](#) [TVP00WCI1535P](#)
[TVP00WCI1135SA](#) [TVP00WCI0935SA](#) [TVPS00FCI1535P](#) [TVP00WCI1735P](#) [TVP00WCI0998P](#) [TVP00WCI1735S](#)
[TVP00WCI1932P](#) [TVP00WCI0935S](#) [TVP00WCI2561P](#) [TVP00WCI1535SA](#) [TVP00WCI1935PA](#) [TVP00WCI1799P](#)
[TVP00WCI1398SB](#) [TVP00WCI0998SC](#) [TVP00WCI1308SC](#) [TVP00WCI1535PA](#) [TVP00WCI1326SA](#)
[TVP00WCI1932S](#) [TVP00WCI1911S](#) [TVP00WCI0935PC](#) [TVP00WCI2535S](#) [TVP00WCI1102S](#) [TVP00WCI2535P](#)
[TVP00WCI2535PA](#) [TVP00WCI1104P](#) [TVP00WCI1535SB](#) [TVP00WCI0935SB](#) [TVP00WCI1535SC](#)
[TVP00WCI1199SA](#) [TVP00WCI1102PA](#) [TVP00WCI1119PA](#) [TVP00WCI1102SA](#) [TVP00WCI1105SB](#)
[TVP00WCI1308PA](#) [TVP00WCI1199SC](#) [TVP00WCI0998SB](#) [TVP00WCI1119P](#) [TVP00WCI1935S](#) [TVP00WCI0909S](#)
[TVP00WCI1935P](#) [TVP00WCI1304P](#) [TVP00WCI1932PA](#) [TVP00WCI2314PB](#) [TVP00WCI1326PA](#) [TVP00WCI1518S](#)
[TVP00WCI1199PB](#) [TVP00WCI1308SB](#) [TVP00WCI1304PB](#) [TVP00WCI1326S](#) [TVP00WCI1102SC](#)
[TVP00WCI1135SB](#) [TVP00WCI1335PC](#) [TVP00WCI1398PB](#) [TVP00WCI1135SC](#) [TVP00WCI0935PB](#)
[TVP00WCI1519PA](#) [TVP00WCI1398SA](#) [TVP00WCI1326PC](#) [TVP00WCI2504P](#) [TVP00WCI1135PA](#)
[TVP00WCI1335PB](#) [TVP00WCI1135PB](#) [TVP00WCI1935SA](#) [TVP00WCI1304S](#) [TVP00WCI2141SB](#) [TVP00WCI1708S](#)
[TVP00WCI2314P](#) [TVP00WCI1104SC](#) [TVP00WCI2135PA](#) [TVP00WCI0935SC](#) [TVP00WCI2335SA](#)
[TVP00WCI0998PC](#) [TVP00WCI2111S](#) [TVP00WCI1198PA](#) [TVP00WCI2335P](#) [TVP00WCI1304PC](#) [TVP00WCI1198S](#)
[TVP00WCI1304SA](#) [TVP00WCI1335S](#) [TVP00WCI2141SC](#) [TVP00WCI2111P](#) [TVP00WCI1135PC](#) [TVP00WCI1308SA](#)
[TVP00WCI1198SC](#) [TVP00WCI1104PA](#) [TVP00WCI1735SA](#) [TVP00WCI1304PA](#) [TVP00WCI1105PB](#)
[TVP00WCI2141PB](#) [TVP00WCI1326SC](#) [TVP00WCI1597P](#) [TVP00WCI1735PA](#) [TVP00WCI0998PB](#)
[TVP00WCI1308PC](#)