PART NUMBER**5400BDA-ROCV**

**Rochester Electronics
Manufactured Components**

Rochester branded components are manufactured using either die/wafers purchased from the original suppliers or Rochester wafers recreated from the original IP. All re-creations are done with the approval of the Original Component Manufacturer. (OCM)

Parts are tested using original factory test programs or Rochester developed test solutions to guarantee product meets or exceeds the OCM data sheet.

Quality Overview

- ISO-9001
- AS9120 certification
- Qualified Manufacturers List (QML) MIL-PRF-38535
 - Class Q Military
 - Class V Space Level

Qualified Suppliers List of Distributors (QSLD)

- Rochester is a critical supplier to DLA and meets all industry and DLA standards.

Rochester Electronics, LLC is committed to supplying products that satisfy customer expectations for quality and are equal to those originally supplied by industry manufacturers.

The original manufacturer's datasheet accompanying this document reflects the performance and specifications of the Rochester manufactured version of this device. Rochester Electronics guarantees the performance of its semiconductor products to the original OCM specifications. 'Typical' values are for reference purposes only. Certain minimum or maximum ratings may be based on product characterization, design, simulation, or sample testing.

SN5400

SNx400, SNx4LS00, and SNx4S00 Quadruple 2-Input Positive-NAND

The SNx4xx00 devices contain four independent, 2-input NAND gates. The devices perform the Boolean function $Y = \overline{A \cdot B}$ or $Y = \overline{A} + \overline{B}$ in positive logic.

Rochester Electronics Manufactured Components

Rochester branded components are manufactured using either die/wafers purchased from the original suppliers or Rochester wafers recreated from the original IP. All re-creations are done with the approval of the Original Component Manufacturer (OCM).

Parts are tested using original factory test programs or Rochester developed test solutions to guarantee product meets or exceeds the OCM data sheet.

Quality Overview

- ISO-9001
- AS9120 certification
- Qualified Manufacturers List (QML) MIL-PRF-35835
 - Class Q Military
 - Class V Space Level
- Qualified Suppliers List of Distributors (QSLD)
 - Rochester is a critical supplier to DLA and meets all industry and DLA standards.

Rochester Electronics, LLC is committed to supplying products that satisfy customer expectations for quality and are equal to those originally supplied by industry manufacturers.

The original manufacturer's datasheet accompanying this document reflects the performance and specifications of the Rochester manufactured version of this device. Rochester Electronics guarantees the performance of its semiconductor products to the original OCM specifications. 'Typical' values are for reference purposes only. Certain minimum or maximum ratings may be based on product characterization, design, simulation, or sample testing.

FOR REFERENCE ONLY

SNx400, SNx4LS00, and SNx4S00 Quadruple 2-Input Positive-NAND Gates

1 Features

- Package Options Include:
 - Plastic Small-Outline (D, NS, PS)
 - Shrink Small-Outline (DB)
 - Ceramic Flat (W)
 - Ceramic Chip Carriers (FK)
 - Standard Plastic (N)
 - Ceramic (J)
- Also Available as Dual 2-Input Positive-NAND Gate in Small-Outline (PS) Package
- Inputs Are TTL Compliant; $V_{IH} = 2\text{ V}$ and $V_{IL} = 0.8\text{ V}$
- Inputs Can Accept 3.3-V or 2.5-V Logic Inputs
- SN5400, SN54LS00, and SN54S00 are Characterized For Operation Over the Full Military Temperature Range of -55°C to 125°C

2 Applications

- AV Receivers
- Portable Audio Docks
- Blu-Ray Players
- Home Theater
- MP3 Players or Recorders
- Personal Digital Assistants (PDAs)

3 Description

The SNx4xx00 devices contain four independent, 2-input NAND gates. The devices perform the Boolean function $Y = A \cdot B$ or $Y = \overline{A + B}$ in positive logic.

Device Information⁽¹⁾

| PART NUMBER | PACKAGE | BODY SIZE (NOM) |
|---------------------------------------|-----------|--------------------|
| SN74LS00DB | SSOP (14) | 6.20 mm × 5.30 mm |
| SN7400D, SN74LS00D, SN74S00D | SOIC (14) | 8.65 mm × 3.91 mm |
| SN74LS00NSR | PDIP (14) | 19.30 × 6.35 mm |
| SNJ5400J, SNJ54LS00J, SNJ54S00J | CDIP (14) | 19.56 mm × 6.67 mm |
| SNJ5400W, SNJ54LS00W, SNJ54S00W | CFP (14) | 9.21 mm × 5.97 mm |
| SN54LS00FK, SN54S00FK | LCCC (20) | 8.89 mm × 8.89 mm |
| SN7400NS, SN74LS00NS, SN74S00NS | SO (14) | 10.30 mm × 5.30 mm |
| SN7400PS, SN74LS00PS | SO (8) | 6.20 mm × 5.30 mm |

(1) For all available packages, see the orderable addendum at the end of the data sheet.

Logic Diagram, Each Gate (Positive Logic)



Table of Contents

| | | | |
|---|-----------|--|-----------|
| 1 Features | 1 | 8.1 Overview | 10 |
| 2 Applications | 1 | 8.2 Functional Block Diagram | 10 |
| 3 Description | 1 | 8.3 Feature Description | 10 |
| 4 Revision History | 2 | 8.4 Device Functional Modes | 10 |
| 5 Pin Configuration and Functions | 3 | 9 Application and Implementation | 11 |
| 6 Specifications | 4 | 9.1 Application Information | 11 |
| 6.1 Absolute Maximum Ratings | 4 | 9.2 Typical Application | 11 |
| 6.2 ESD Ratings: SN74LS00 | 4 | 10 Power Supply Recommendations | 12 |
| 6.3 Recommended Operating Conditions | 4 | 11 Layout | 13 |
| 6.4 Thermal Information | 6 | 11.1 Layout Guidelines | 13 |
| 6.5 Electrical Characteristics: SNx400 | 6 | 11.2 Layout Example | 13 |
| 6.6 Electrical Characteristics: SNx4LS00 | 6 | 12 Device and Documentation Support | 14 |
| 6.7 Electrical Characteristics: SNx4S00 | 6 | 12.1 Documentation Support | 14 |
| 6.8 Switching Characteristics: SNx400 | 7 | 12.2 Related Links | 14 |
| 6.9 Switching Characteristics: SNx4LS00 | 7 | 12.3 Receiving Notification of Documentation Updates | 14 |
| 6.10 Switching Characteristics: SNx4S00 | 7 | 12.4 Community Resources | 14 |
| 6.11 Typical Characteristics | 8 | 12.5 Trademarks | 14 |
| 7 Parameter Measurement Information | 9 | 12.6 Electrostatic Discharge Caution | 14 |
| 7.1 Propagation Delays, Setup and Hold Times, and Pulse Width | 9 | 12.7 Glossary | 14 |
| 8 Detailed Description | 10 | 13 Mechanical, Packaging, and Orderable Information | 15 |

4 Revision History

NOTE: Page numbers for previous revisions may differ from page numbers in the current version.

| Changes from Revision C (November 2016) to Revision D | Page |
|--|----------|
| • Changed <i>Typical Application Diagram</i> see <i>Application and Implementation</i> section | 1 |

| Changes from Revision B (October 2003) to Revision C | Page |
|--|----------|
| • Added <i>ESD Ratings</i> table, <i>Feature Description</i> section, <i>Device Functional Modes</i> , <i>Application and Implementation Power Supply Recommendations</i> section, <i>Layout</i> section, <i>Device and Documentation Support</i> section, and <i>Mechanical, Packaging, and Orderable Information</i> section. | 1 |
| • Changed <i>Ordering Information</i> table to <i>Device Comparison Table</i> ; see <i>Package Option Addendum</i> at the end of the data sheet | 1 |
| • Changed Package thermal impedance, $R_{\theta JA}$, values in <i>Thermal Information</i> table From: 86°C/W To: 90.9°C/W (D), From: 96°C/W To: 102.8°C/W (DB), From: 80°C/W To: 54.8°C/W (N), and From: 76°C/W To: 89.7°C/W (NS) | 6 |

5 Pin Configuration and Functions

**SN5400 J, SN54xx00 J and W, SN74xx00 D, N, and NS, or
SN74LS00 D, DB, N, and NS Packages**
14-Pin CDIP, CFP, SOIC, PDIP, SO, or SSOP
Top View

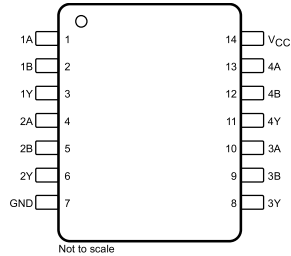

SN5400 W Package
14-Pin CFP
Top View

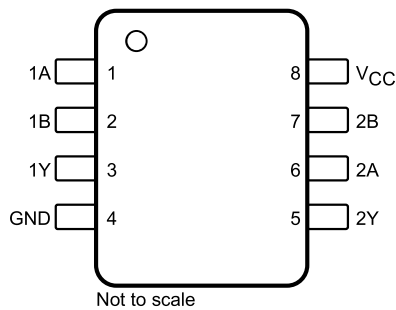

SN74xx00 PS Package
18-Pin SO
Top View

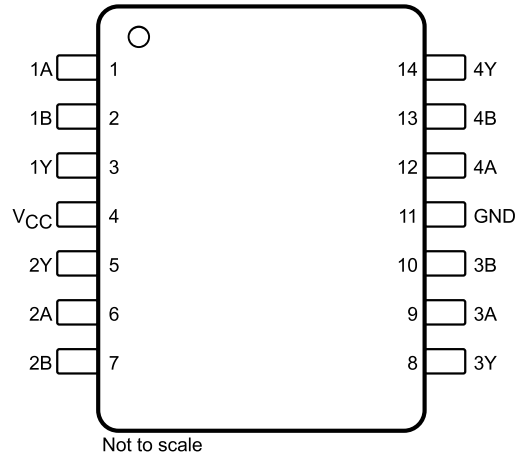

SN54xx00 FK Package
20-Pin LCCC
Top View

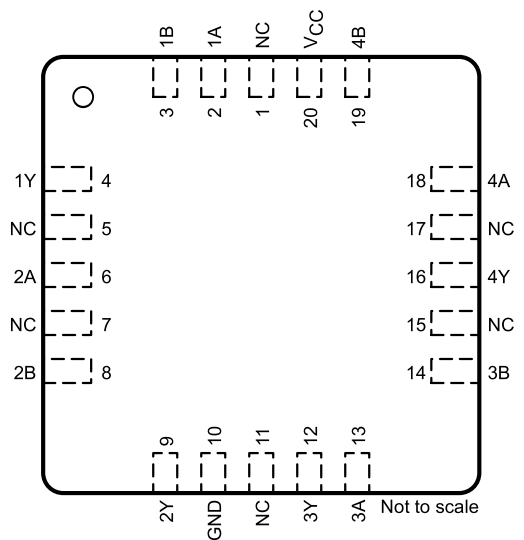

Pin Functions

| NAME | PIN | | | | I/O | DESCRIPTION |
|------|---------------------------------|---------------|--------------|------|-----|---------------|
| | CDIP, CFP, SOIC, PDIP, SO, SSOP | SO (SN74xx00) | CFP (SN5400) | LCCC | | |
| 1A | 1 | 1 | 1 | 2 | I | Gate 1 input |
| 1B | 2 | 2 | 2 | 3 | I | Gate 1 input |
| 1Y | 3 | 3 | 3 | 4 | O | Gate 1 output |
| 2A | 4 | 6 | 6 | 6 | I | Gate 2 input |
| 2B | 5 | 7 | 7 | 8 | I | Gate 2 input |
| 2Y | 6 | 5 | 5 | 9 | O | Gate 2 output |
| 3A | 10 | — | 9 | 13 | I | Gate 3 input |
| 3B | 9 | — | 10 | 14 | I | Gate 3 input |

Pin Functions (continued)

| NAME | PIN | | | | I/O | DESCRIPTION |
|-----------------|---------------------------------|---------------|--------------|---------------------|-----|---------------|
| | CDIP, CFP, SOIC, PDIP, SO, SSOP | SO (SN74xx00) | CFP (SN5400) | LCCC | | |
| 3Y | 8 | — | 8 | 12 | O | Gate 3 output |
| 4A | 13 | — | 12 | 18 | I | Gate 4 input |
| 4B | 12 | — | 13 | 19 | I | Gate 4 input |
| 4Y | 11 | — | 14 | 16 | O | Gate 4 output |
| GND | 7 | 4 | 11 | 10 | — | Ground |
| NC | — | — | — | 1, 5, 7, 11, 15, 17 | — | No connect |
| V _{CC} | 14 | 8 | 4 | 20 | — | Power supply |

6 Specifications

6.1 Absolute Maximum Ratings

over operating free-air temperature range (unless otherwise noted)⁽¹⁾

| | MIN | MAX | UNIT |
|--|--------------------|-----|------|
| Supply voltage, V _{CC} ⁽²⁾ | | 7 | V |
| Input voltage | SNx400 and SNxS400 | 5.5 | V |
| | SNx4LS00 | 7 | |
| Junction temperature, T _J | | 150 | °C |
| Storage temperature, T _{stg} | –65 | 150 | °C |

- (1) Stresses beyond those listed under *Absolute Maximum Ratings* may cause permanent damage to the device. These are stress ratings only, which do not imply functional operation of the device at these or any other conditions beyond those indicated under *Recommended Operating Conditions*. Exposure to absolute-maximum-rated conditions for extended periods may affect device reliability.
- (2) Voltage values are with respect to network ground terminal.

6.2 ESD Ratings: SN74LS00

| | VALUE | UNIT |
|--|--|-------|
| V _(ESD) Electrostatic discharge | Human-body model (HBM), per ANSI/ESDA/JEDEC JS-001 ⁽¹⁾ | ±500 |
| | Charged-device model (CDM), per JEDEC specification JESD22-C101 ⁽²⁾ | ±2000 |

- (1) JEDEC document JEP155 states that 500-V HBM allows safe manufacturing with a standard ESD control process. Manufacturing with less than 500-V HBM is possible with the necessary precautions.
- (2) JEDEC document JEP157 states that 250-V CDM allows safe manufacturing with a standard ESD control process. Manufacturing with less than 250-V CDM is possible with the necessary precautions. Pins listed as ±2000 V may actually have higher performance. ESD Tested on SN74LS00N package.

6.3 Recommended Operating Conditions

over operating free-air temperature range (unless otherwise noted)

| | MIN | NOM | MAX | UNIT |
|---|--------------------------------|------|------|------|
| V _{CC} Supply voltage | SN54xx00 | 5 | 5.5 | V |
| | SN74xx00 | 4.75 | 5 | |
| V _{IH} High-level input voltage | 2 | | | V |
| V _{IL} Low-level input voltage | SNx400, SN7LS400, and SNx4S00 | | 0.8 | V |
| | SN54LS00 | | 0.7 | |
| I _{OH} High-level output current | SN5400, SN54LS00, and SN74LS00 | | –0.4 | mA |
| | SNx4S00 | | –1 | |
| I _{OL} Low-level output current | SNx400 | | 16 | mA |
| | SN5LS400 | | 4 | |
| | SN7LS400 | | 8 | |
| | SNx4S00 | | 20 | |

Recommended Operating Conditions (continued)

over operating free-air temperature range (unless otherwise noted)

| | | | MIN | NOM | MAX | UNIT |
|----------------|--------------------------------|----------|-----|-----|-----|------|
| T _A | Operating free-air temperature | SN54xx00 | -55 | | 125 | °C |
| | | SN74xx00 | 0 | | 70 | |

6.4 Thermal Information

| THERMAL METRIC ⁽¹⁾⁽²⁾ | SN74LS00 | | | | UNIT |
|---|----------|-----------|----------|---------|------|
| | D (SOIC) | DB (SSOP) | N (PDIP) | NS (SO) | |
| | 14 PINS | 14 PINS | 14 PINS | 14 PINS | |
| R _{θJA} Junction-to-ambient thermal resistance | 90.9 | 102.8 | 54.8 | 89.7 | °C/W |
| R _{θJC(top)} Junction-to-case (top) thermal resistance | 51.9 | 53.3 | 42.1 | 48.1 | °C/W |
| R _{θJB} Junction-to-board thermal resistance | 48 | 53.4 | 34.8 | 50.1 | °C/W |
| ψ _{JT} Junction-to-top characterization parameter | 18.6 | 16.5 | 26.9 | 16.7 | °C/W |
| ψ _{JB} Junction-to-board characterization parameter | 47.8 | 52.9 | 34.7 | 49.8 | °C/W |

(1) For more information about traditional and new thermal metrics, see the [Semiconductor and IC Package Thermal Metrics](#) application report.

(2) The package thermal impedance is calculated in accordance with JESD 51-7.

6.5 Electrical Characteristics: SNx400

over operating free-air temperature range (unless otherwise noted)

| PARAMETER | TEST CONDITIONS | MIN | TYP | MAX | UNIT | |
|------------------|---|--------|-----|------|------|----|
| V _{IK} | V _{CC} = MIN and I _I = -12 mA | | | -1.5 | V | |
| V _{OH} | V _{CC} = MIN, V _{IL} = 0.8 V, and I _{OH} = -0.4 mA | 2.4 | 3.4 | | V | |
| V _{OL} | V _{CC} = MIN, V _{IH} = 2 V, and I _{OL} = 16 mA | | 0.2 | 0.4 | V | |
| I _I | V _{CC} = MAX and V _I = 5.5 V | | | 1 | mA | |
| I _{IH} | V _{CC} = MAX and V _I = 2.4 V | | | 40 | μA | |
| I _{IL} | V _{CC} = MAX and V _I = 0.4 V | | | -1.6 | mA | |
| I _{OS} | V _{CC} = MAX | SN5400 | | -20 | -55 | mA |
| | | SN7400 | | -18 | -55 | |
| I _{CCH} | V _{CC} = MAX and V _I = 0 V | | 4 | 8 | mA | |
| I _{CCL} | V _{CC} = MAX and V _I = 4.5 V | | 12 | 22 | mA | |

6.6 Electrical Characteristics: SNx4LS00

over operating free-air temperature range (unless otherwise noted)

| PARAMETER | TEST CONDITIONS | MIN | TYP | MAX | UNIT |
|------------------|---|-----------------------------------|------|------|------|
| V _{IK} | V _{CC} = MIN and I _I = -18 mA | | | -1.5 | V |
| V _{OH} | V _{CC} = MIN, V _{IL} = MAX, and I _{OH} = -0.4 mA | 2.5 | 3.4 | | V |
| V _{OL} | V _{CC} = MIN and V _{IH} = 2 V | I _{OL} = 4 mA | 0.25 | 0.4 | V |
| | | I _{OL} = 8 mA (SN74LS00) | 0.35 | 0.5 | |
| I _I | V _{CC} = MAX and V _I = 7 V | | | 0.1 | mA |
| I _{IH} | V _{CC} = MAX and V _I = 2.7 V | | | 20 | μA |
| I _{IL} | V _{CC} = MAX and V _I = 0.4 V | | | -0.4 | mA |
| I _{OS} | V _{CC} = MAX | -20 | | -100 | mA |
| I _{CCH} | V _{CC} = MAX and V _I = 0 V | | 0.8 | 1.6 | mA |
| I _{CCL} | V _{CC} = MAX and V _I = 4.5 V | | 2.4 | 4.4 | mA |

6.7 Electrical Characteristics: SNx4S00

over operating free-air temperature range (unless otherwise noted)

| PARAMETER | TEST CONDITIONS | MIN | TYP | MAX | UNIT |
|-----------------|---|-----|-----|------|------|
| V _{IK} | V _{CC} = MIN and I _I = -18 mA | | | -1.2 | V |
| V _{OH} | V _{CC} = MIN, V _{IL} = 0.8 V, and I _{OH} = -1 mA | 2.5 | 3.4 | | V |
| V _{OL} | V _{CC} = MIN, V _{IH} = 2 V, and I _{OL} = 20 mA | | | 0.5 | V |
| I _I | V _{CC} = MAX and V _I = 5.5 V | | | 1 | mA |
| I _{IH} | V _{CC} = MAX and V _I = 2.7 V | | | 50 | μA |
| I _{IL} | V _{CC} = MAX and V _I = 0.5 V | | | -2 | mA |

Electrical Characteristics: SNx4S00 (continued)

over operating free-air temperature range (unless otherwise noted)

| PARAMETER | TEST CONDITIONS | MIN | TYP | MAX | UNIT |
|-----------|---|-----|-----|------|------|
| I_{OS} | $V_{CC} = \text{MAX}$ | -40 | | -100 | mA |
| I_{CCH} | $V_{CC} = \text{MAX}$ and $V_I = 0 \text{ V}$ | | 10 | 16 | mA |
| I_{CCL} | $V_{CC} = \text{MAX}$ and $V_I = 4.5 \text{ V}$ | | 20 | 36 | mA |

6.8 Switching Characteristics: SNx400

$V_{CC} = 5 \text{ V}$, $T_A = 25^\circ\text{C}$, and over operating free-air temperature range (unless otherwise noted). See [Figure 2](#).

| PARAMETER | FROM (INPUT) | TO (OUTPUT) | TEST CONDITIONS | MIN | TYP | MAX | UNIT |
|-----------|--------------|-------------|--|-----|-----|-----|------|
| t_{PLH} | A or B | Y | $R_L = 400 \ \Omega$ and $C_L = 15 \text{ pF}$ | | 11 | 22 | ns |
| t_{PHL} | | | | | 7 | 15 | |

6.9 Switching Characteristics: SNx4LS00

$V_{CC} = 5 \text{ V}$, $T_A = 25^\circ\text{C}$, and over operating free-air temperature range (unless otherwise noted). See [Figure 2](#).

| PARAMETER | FROM (INPUT) | TO (OUTPUT) | TEST CONDITIONS | MIN | TYP | MAX | UNIT |
|-----------|--------------|-------------|---|-----|-----|-----|------|
| t_{PLH} | A or B | Y | $R_L = 2 \text{ k}\Omega$ and $C_L = 15 \text{ pF}$ | | 9 | 15 | ns |
| t_{PHL} | | | | | 10 | 15 | |

6.10 Switching Characteristics: SNx4S00

$V_{CC} = 5 \text{ V}$, $T_A = 25^\circ\text{C}$, and over operating free-air temperature range (unless otherwise noted). See [Figure 2](#).

| PARAMETER | FROM (INPUT) | TO (OUTPUT) | TEST CONDITIONS | MIN | TYP | MAX | UNIT |
|-----------|--------------|-------------|--|-----|-----|-----|------|
| t_{PLH} | A or B | Y | $R_L = 280 \ \Omega$ and $C_L = 15 \text{ pF}$ | | 3 | 4.5 | ns |
| | | | $R_L = 280 \ \Omega$ and $C_L = 50 \text{ pF}$ | | 4.5 | | |
| t_{PHL} | A or B | Y | $R_L = 280 \ \Omega$ and $C_L = 15 \text{ pF}$ | | 3 | 5 | |
| | | | $R_L = 280 \ \Omega$ and $C_L = 50 \text{ pF}$ | | 5 | | |

6.11 Typical Characteristics

$C_L = 15 \text{ pF}$

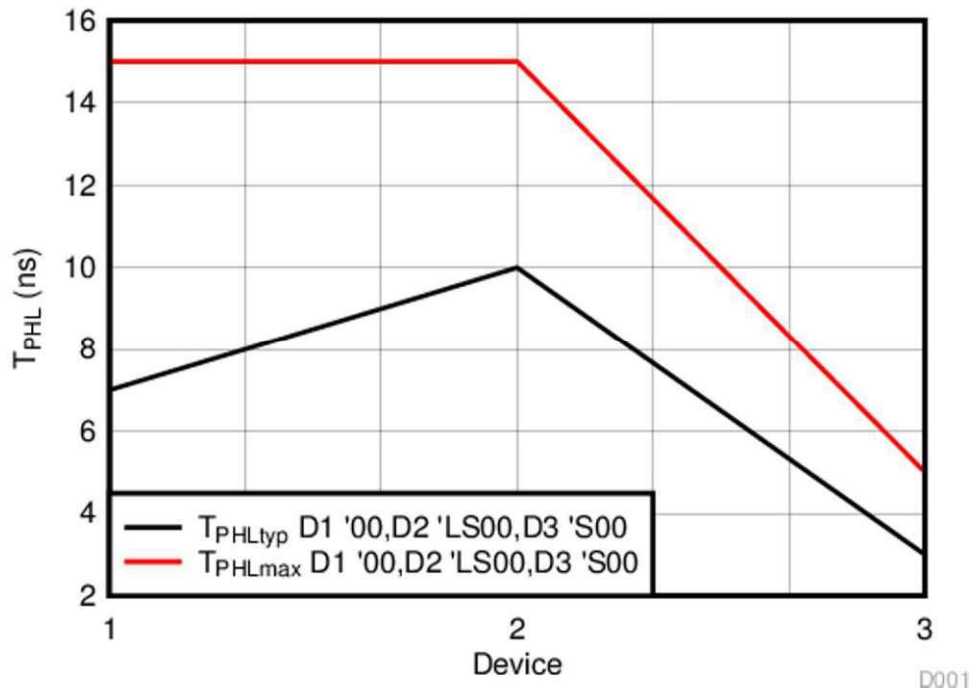
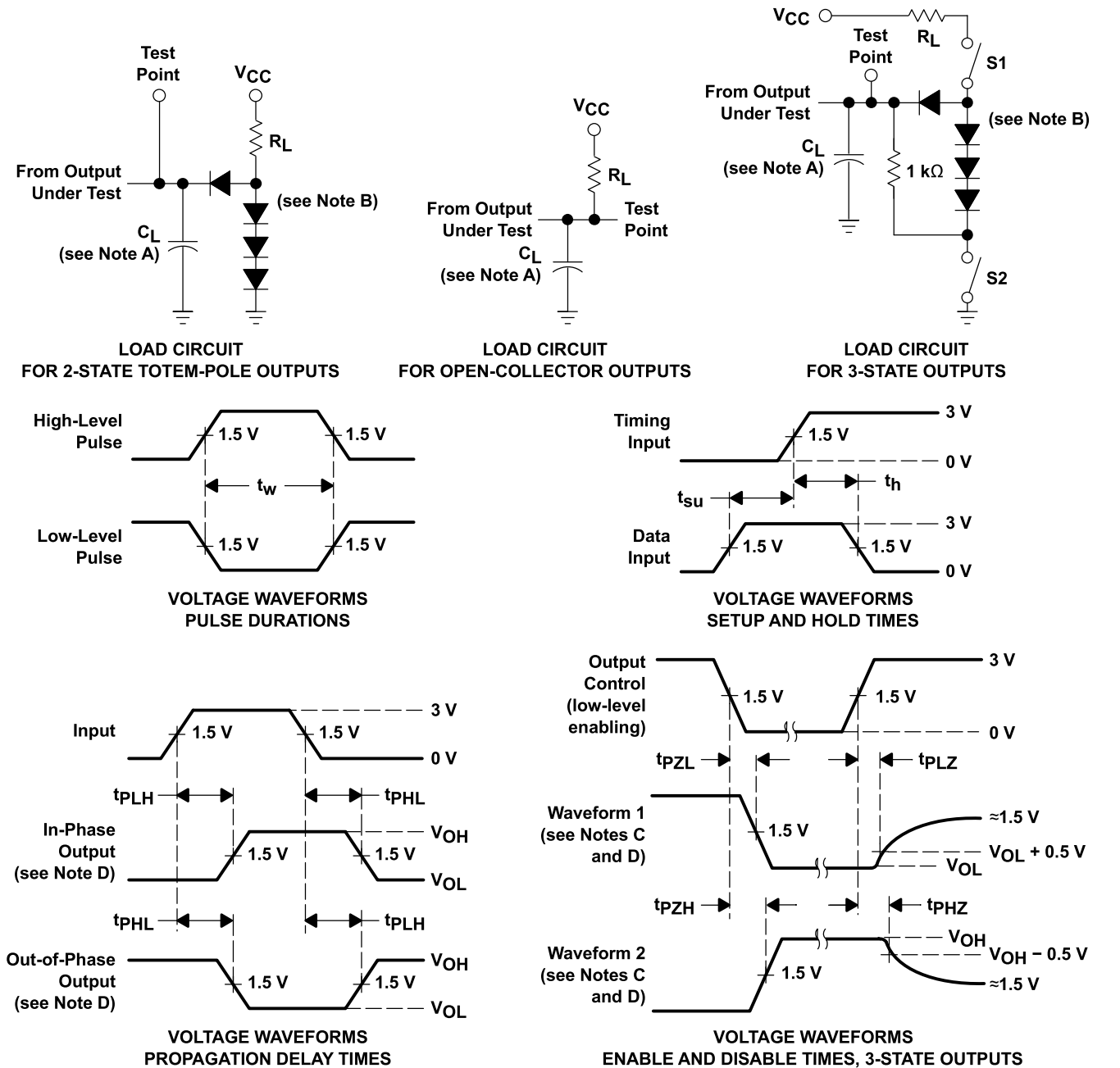

Figure 1. T_{PHL} (Across Devices)

7 Parameter Measurement Information

7.1 Propagation Delays, Setup and Hold Times, and Pulse Width



- NOTES:
- C_L includes probe and jig capacitance.
 - All diodes are 1N3064 or equivalent.
 - Waveform 1 is for an output with internal conditions such that the output is low except when disabled by the output control. Waveform 2 is for an output with internal conditions such that the output is high except when disabled by the output control.
 - S1 and S2 are closed for t_{PLH} , t_{PHL} , t_{PHZ} , and t_{PLZ} ; S1 is open and S2 is closed for t_{PZH} ; S1 is closed and S2 is open for t_{PZL} .
 - All input pulses are supplied by generators having the following characteristics: $PRR \leq 1$ MHz, $Z_O \approx 50 \Omega$; t_r and $t_f \leq 7$ ns for Series 54/74 devices and t_r and $t_f \leq 2.5$ ns for Series 54S/74S devices.
 - The outputs are measured one at a time with one input transition per measurement.

Figure 2. Load Circuits and Voltage Waveforms

8 Detailed Description

8.1 Overview

The SNx4xx00 devices are quadruple, 2-input NAND gates which perform the Boolean function $Y = \overline{A \cdot B}$ or $Y = \overline{A} + \overline{B}$ in positive logic.

8.2 Functional Block Diagram



8.3 Feature Description

The operating voltage of SN74xx00 is from 4.75-V to 5.25-V V_{CC} . The operating voltage of SN54xx00 is from 4.5-V to 5.5-V V_{CC} . The SN54xx00 devices are rated from -55°C to 125°C whereas SN74xx00 device are rated from 0°C to 70°C .

8.4 Device Functional Modes

Table 1 lists the functions of the devices.

Table 1. Functional Table (Each Gate)

| INPUTS | | OUTPUT |
|--------|---|--------|
| A | B | Y |
| H | H | L |
| L | X | H |
| X | L | H |

9 Application and Implementation

NOTE

Information in the following applications sections is not part of the TI component specification, and TI does not warrant its accuracy or completeness. TI's customers are responsible for determining suitability of components for their purposes. Customers should validate and test their design implementation to confirm system functionality.

9.1 Application Information

The SNx4xx00 devices are quadruple, 2-input NAND gate. A typical application of NAND gate can be as an error indicator as shown in [Figure 3](#). If either of the sensor has an error, the error flag is high to indicate system error.

9.2 Typical Application

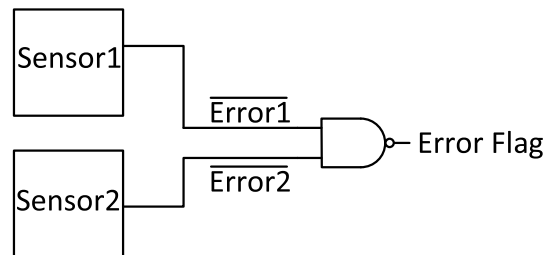

Figure 3. Typical Application Diagram

9.2.1 Design Requirements

These devices use BJT technology and have unbalanced output drive with I_{OL} and I_{OH} specified as per the [Recommended Operating Conditions](#).

9.2.2 Detailed Design Procedure

- Recommended Input Conditions:
 - The inputs are TTL compliant.
 - Because the base-emitter junction at the inputs breaks down, no voltage greater than 5.5 V must be applied to the inputs.
 - Specified high and low levels: See V_{IH} and V_{IL} in [Recommended Operating Conditions](#).
- Recommended Output Conditions:
 - No more than one output must be shorted at a time as per the [Electrical Characteristics: SNx400](#) for thermal stability and reliability.
 - For high-current applications, consider thermal characteristics of the package listed in [Thermal Information](#).

Typical Application (continued)

9.2.3 Application Curve

$C_L = 15 \text{ pF}$

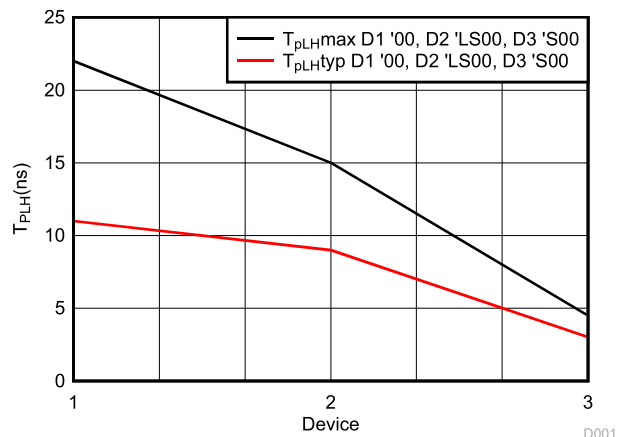

Figure 4. T_{PLH} (Across Devices)

10 Power Supply Recommendations

The power supply can be any voltage between the minimum and maximum supply voltage rating located in [Recommended Operating Conditions](#) for each of the SNx4LS00, SNx4S00, and SNx400 devices.

Each V_{CC} pin must have a good bypass capacitor to prevent power disturbance. For devices with a single supply, $0.1 \mu\text{F}$ is recommended; if there are multiple V_{CC} pins, then $0.01 \mu\text{F}$ or $0.022 \mu\text{F}$ is recommended for each power pin. It is acceptable to parallel multiple bypass capacitors to reject different frequencies of noise. A $0.1 \mu\text{F}$ and a $1 \mu\text{F}$ are commonly used in parallel. The bypass capacitor must be installed as close to the power pin as possible for best results.

11 Layout

11.1 Layout Guidelines

When using multiple bit logic, devices inputs must never float.

Devices with multiple-emitter inputs (SN74 and SN74S series) need special care. Because no voltage greater than 5.5 V must be applied to the inputs (if exceeded, the base-emitter junction at the inputs breaks down), the inputs of these devices must be connected to the supply voltage, V_{CC} , through series resistor, R_S (see Figure 5). This resistor must be dimensioned such that the current flowing into the gate or gates, which results from overvoltage, does not exceed 1 mA. However, because the high-level input current of the circuits connected to the gate flows through this resistor, the resistor must be dimensioned so that the voltage drop across it still allows the required high level. Equation 1 and Equation 2 are for dimensioning resistor, R_S , and several inputs can be connected to a high level through a single resistor if the following conditions are met.

$$R_{S(\min)} = \frac{V_{CCP} - 5.5 \text{ V}}{1 \text{ mA}} \quad (1)$$

$$R_{S(\max)} = \frac{V_{CC(\min)} - 2.4 \text{ V}}{n I_{IH}}$$

where

- n = number of inputs connected
 - I_{IH} = high input current (typical 40 μA)
 - $V_{CC(\min)}$ = minimum supply voltage, V_{CC}
 - V_{CCP} = maximum peak voltage of the supply voltage, V_{CC} (about 7 V)
- (2)

11.2 Layout Example

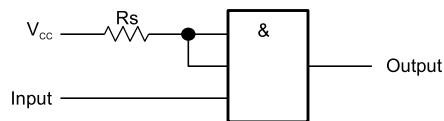

Figure 5. Series Resistor Connected to Unused Inputs of Multiple-Emitter Transistors

12 Device and Documentation Support

12.1 Documentation Support

12.1.1 Related Documentation

For related documentation see the following:

[Designing With Logic](#) (SDYA009)

12.2 Related Links

The table below lists quick access links. Categories include technical documents, support and community resources, tools and software, and quick access to sample or buy.

Table 2. Related Links

| PARTS | PRODUCT FOLDER | SAMPLE & BUY | TECHNICAL DOCUMENTS | TOOLS & SOFTWARE | SUPPORT & COMMUNITY |
|----------|----------------------------|----------------------------|----------------------------|----------------------------|----------------------------|
| SN5400 | Click here | Click here | Click here | Click here | Click here |
| SN54LS00 | Click here | Click here | Click here | Click here | Click here |
| SN54S00 | Click here | Click here | Click here | Click here | Click here |
| SN7400 | Click here | Click here | Click here | Click here | Click here |
| SN74LS00 | Click here | Click here | Click here | Click here | Click here |
| SN74S00 | Click here | Click here | Click here | Click here | Click here |

12.3 Receiving Notification of Documentation Updates

To receive notification of documentation updates, navigate to the device product folder on ti.com. In the upper right corner, click on *Alert me* to register and receive a weekly digest of any product information that has changed. For change details, review the revision history included in any revised document.

12.4 Community Resources

The following links connect to TI community resources. Linked contents are provided "AS IS" by the respective contributors. They do not constitute TI specifications and do not necessarily reflect TI's views; see TI's [Terms of Use](#).

TI E2E™ Online Community *TI's Engineer-to-Engineer (E2E) Community*. Created to foster collaboration among engineers. At e2e.ti.com, you can ask questions, share knowledge, explore ideas and help solve problems with fellow engineers.

Design Support *TI's Design Support* Quickly find helpful E2E forums along with design support tools and contact information for technical support.

12.5 Trademarks

E2E is a trademark of Texas Instruments.
All other trademarks are the property of their respective owners.

12.6 Electrostatic Discharge Caution



These devices have limited built-in ESD protection. The leads should be shorted together or the device placed in conductive foam during storage or handling to prevent electrostatic damage to the MOS gates.

12.7 Glossary

SLYZ022 — *TI Glossary*.

This glossary lists and explains terms, acronyms, and definitions.

13 Mechanical, Packaging, and Orderable Information

The following pages include mechanical, packaging, and orderable information. This information is the most current data available for the designated devices. This data is subject to change without notice and revision of this document. For browser-based versions of this data sheet, refer to the left-hand navigation.



www.ti.com

PACKAGE OPTION ADDENDUM

24-Aug-2018

PACKAGING INFORMATION

| Orderable Device | Status (1) | Package Type | Package Drawing | Pins | Package Qty | Eco Plan (2) | Lead/Ball Finish (6) | MSL Peak Temp (3) | Op Temp (°C) | Device Marking (4/5) | Samples |
|------------------|------------|--------------|-----------------|------|-------------|--------------|----------------------|--------------------|--------------|----------------------|---------|
| JM38510/00104BCA | ACTIVE | CDIP | J | 14 | 1 | TBD | A42 | N / A for Pkg Type | -55 to 125 | JM38510/ 00104BCA | Samples |
| JM38510/00104BDA | ACTIVE | CFP | W | 14 | 1 | TBD | A42 | N / A for Pkg Type | -55 to 125 | JM38510/ 00104BDA | Samples |
| JM38510/07001BCA | ACTIVE | CDIP | J | 14 | 1 | TBD | A42 | N / A for Pkg Type | -55 to 125 | JM38510/ 07001BCA | Samples |
| JM38510/07001BDA | ACTIVE | CFP | W | 14 | 1 | TBD | A42 | N / A for Pkg Type | -55 to 125 | JM38510/ 07001BDA | Samples |
| JM38510/30001B2A | ACTIVE | LCCC | FK | 20 | 1 | TBD | POST-PLATE | N / A for Pkg Type | -55 to 125 | JM38510/ 30001B2A | Samples |
| JM38510/30001BCA | ACTIVE | CDIP | J | 14 | 1 | TBD | A42 | N / A for Pkg Type | -55 to 125 | JM38510/ 30001BCA | Samples |
| JM38510/30001BDA | ACTIVE | CFP | W | 14 | 1 | TBD | A42 | N / A for Pkg Type | -55 to 125 | JM38510/ 30001BDA | Samples |
| JM38510/30001SCA | ACTIVE | CDIP | J | 14 | 1 | TBD | A42 | N / A for Pkg Type | -55 to 125 | JM38510/30001S CA | Samples |
| JM38510/30001SDA | ACTIVE | CFP | W | 14 | 1 | TBD | A42 | N / A for Pkg Type | -55 to 125 | JM38510/30001S DA | Samples |
| M38510/00104BCA | ACTIVE | CDIP | J | 14 | 1 | TBD | A42 | N / A for Pkg Type | -55 to 125 | JM38510/ 00104BCA | Samples |
| M38510/00104BDA | ACTIVE | CFP | W | 14 | 1 | TBD | A42 | N / A for Pkg Type | -55 to 125 | JM38510/ 00104BDA | Samples |
| M38510/07001BCA | ACTIVE | CDIP | J | 14 | 1 | TBD | A42 | N / A for Pkg Type | -55 to 125 | JM38510/ 07001BCA | Samples |
| M38510/07001BDA | ACTIVE | CFP | W | 14 | 1 | TBD | A42 | N / A for Pkg Type | -55 to 125 | JM38510/ 07001BDA | Samples |
| M38510/30001B2A | ACTIVE | LCCC | FK | 20 | 1 | TBD | POST-PLATE | N / A for Pkg Type | -55 to 125 | JM38510/ 30001B2A | Samples |
| M38510/30001BCA | ACTIVE | CDIP | J | 14 | 1 | TBD | A42 | N / A for Pkg Type | -55 to 125 | JM38510/ 30001BCA | Samples |
| M38510/30001BDA | ACTIVE | CFP | W | 14 | 1 | TBD | A42 | N / A for Pkg Type | -55 to 125 | JM38510/ 30001BDA | Samples |
| M38510/30001SCA | ACTIVE | CDIP | J | 14 | 1 | TBD | A42 | N / A for Pkg Type | -55 to 125 | JM38510/30001S CA | Samples |



www.ti.com

PACKAGE OPTION ADDENDUM

24-Aug-2018

| Orderable Device | Status ⁽¹⁾ | Package Type | Package Drawing | Pins | Package Qty | Eco Plan ⁽²⁾ | Lead/Ball Finish ⁽⁶⁾ | MSL Peak Temp ⁽³⁾ | Op Temp (°C) | Device Marking ^(4/5) | Samples |
|------------------|-----------------------|--------------|-----------------|------|-------------|-------------------------|---------------------------------|------------------------------|--------------|---------------------------------|---------|
| M38510/30001SDA | ACTIVE | CFP | W | 14 | 1 | TBD | A42 | N / A for Pkg Type | -55 to 125 | JM38510/30001S DA | Samples |
| SN5400J | ACTIVE | CDIP | J | 14 | 1 | TBD | A42 | N / A for Pkg Type | -55 to 125 | SN5400J | Samples |
| SN54LS00J | ACTIVE | CDIP | J | 14 | 1 | TBD | A42 | N / A for Pkg Type | -55 to 125 | SN54LS00J | Samples |
| SN54S00J | ACTIVE | CDIP | J | 14 | 1 | TBD | A42 | N / A for Pkg Type | -55 to 125 | SN54S00J | Samples |
| SN7400D | ACTIVE | SOIC | D | 14 | 50 | Green (RoHS & no Sb/Br) | CU NIPDAU | Level-1-260C-UNLIM | 0 to 70 | 7400 | Samples |
| SN7400DG4 | ACTIVE | SOIC | D | 14 | 50 | Green (RoHS & no Sb/Br) | CU NIPDAU | Level-1-260C-UNLIM | 0 to 70 | 7400 | Samples |
| SN7400N | ACTIVE | PDIP | N | 14 | 25 | Green (RoHS & no Sb/Br) | CU NIPDAU | N / A for Pkg Type | 0 to 70 | SN7400N | Samples |
| SN7400NE4 | ACTIVE | PDIP | N | 14 | 25 | Green (RoHS & no Sb/Br) | CU NIPDAU | N / A for Pkg Type | 0 to 70 | SN7400N | Samples |
| SN74LS00D | ACTIVE | SOIC | D | 14 | 50 | Green (RoHS & no Sb/Br) | CU NIPDAU | Level-1-260C-UNLIM | 0 to 70 | LS00 | Samples |
| SN74LS00DBR | ACTIVE | SSOP | DB | 14 | 2000 | Green (RoHS & no Sb/Br) | CU NIPDAU | Level-1-260C-UNLIM | 0 to 70 | LS00 | Samples |
| SN74LS00DG4 | ACTIVE | SOIC | D | 14 | 50 | Green (RoHS & no Sb/Br) | CU NIPDAU | Level-1-260C-UNLIM | 0 to 70 | LS00 | Samples |
| SN74LS00DR | ACTIVE | SOIC | D | 14 | 2500 | Green (RoHS & no Sb/Br) | CU NIPDAU | Level-1-260C-UNLIM | 0 to 70 | LS00 | Samples |
| SN74LS00DRE4 | ACTIVE | SOIC | D | 14 | 2500 | Green (RoHS & no Sb/Br) | CU NIPDAU | Level-1-260C-UNLIM | 0 to 70 | LS00 | Samples |
| SN74LS00N | ACTIVE | PDIP | N | 14 | 25 | Green (RoHS & no Sb/Br) | CU NIPDAU | N / A for Pkg Type | 0 to 70 | SN74LS00N | Samples |
| SN74LS00NE4 | ACTIVE | PDIP | N | 14 | 25 | Green (RoHS & no Sb/Br) | CU NIPDAU | N / A for Pkg Type | 0 to 70 | SN74LS00N | Samples |
| SN74LS00NSR | ACTIVE | SO | NS | 14 | 2000 | Green (RoHS & no Sb/Br) | CU NIPDAU | Level-1-260C-UNLIM | 0 to 70 | 74LS00 | Samples |
| SN74LS00NSRG4 | ACTIVE | SO | NS | 14 | 2000 | Green (RoHS & no Sb/Br) | CU NIPDAU | Level-1-260C-UNLIM | 0 to 70 | 74LS00 | Samples |
| SN74LS00PSR | ACTIVE | SO | PS | 8 | 2000 | Green (RoHS & no Sb/Br) | CU NIPDAU | Level-1-260C-UNLIM | 0 to 70 | LS00 | Samples |

| Orderable Device | Status ⁽¹⁾ | Package Type | Package Drawing | Pins | Package Qty | Eco Plan ⁽²⁾ | Lead/Ball Finish ⁽⁶⁾ | MSL Peak Temp ⁽³⁾ | Op Temp (°C) | Device Marking ^(4/5) | Samples |
|------------------|-----------------------|--------------|-----------------|------|-------------|-------------------------|---------------------------------|------------------------------|--------------|---------------------------------|---------|
| SN74LS00PSRG4 | ACTIVE | SO | PS | 8 | 2000 | Green (RoHS & no Sb/Br) | CU NIPDAU | Level-1-260C-UNLIM | 0 to 70 | LS00 | Samples |
| SN74S00D | NRND | SOIC | D | 14 | 50 | Green (RoHS & no Sb/Br) | CU NIPDAU | Level-1-260C-UNLIM | 0 to 70 | S00 | |
| SN74S00DE4 | NRND | SOIC | D | 14 | 50 | Green (RoHS & no Sb/Br) | CU NIPDAU | Level-1-260C-UNLIM | 0 to 70 | S00 | |
| SN74S00N | NRND | PDIP | N | 14 | 25 | Green (RoHS & no Sb/Br) | CU NIPDAU | N / A for Pkg Type | 0 to 70 | SN74S00N | |
| SNJ5400J | ACTIVE | CDIP | J | 14 | 1 | TBD | A42 | N / A for Pkg Type | -55 to 125 | SNJ5400J | Samples |
| SNJ5400W | ACTIVE | CFP | W | 14 | 1 | TBD | A42 | N / A for Pkg Type | -55 to 125 | SNJ5400W | Samples |
| SNJ54LS00FK | ACTIVE | LCCC | FK | 20 | 1 | TBD | POST-PLATE | N / A for Pkg Type | -55 to 125 | SNJ54LS00FK | Samples |
| SNJ54LS00J | ACTIVE | CDIP | J | 14 | 1 | TBD | A42 | N / A for Pkg Type | -55 to 125 | SNJ54LS00J | Samples |
| SNJ54LS00W | ACTIVE | CFP | W | 14 | 1 | TBD | A42 | N / A for Pkg Type | -55 to 125 | SNJ54LS00W | Samples |
| SNJ54S00FK | ACTIVE | LCCC | FK | 20 | 1 | TBD | POST-PLATE | N / A for Pkg Type | -55 to 125 | SNJ54S00FK | Samples |
| SNJ54S00J | ACTIVE | CDIP | J | 14 | 1 | TBD | A42 | N / A for Pkg Type | -55 to 125 | SNJ54S00J | Samples |
| SNJ54S00W | ACTIVE | CFP | W | 14 | 1 | TBD | A42 | N / A for Pkg Type | -55 to 125 | SNJ54S00W | Samples |

⁽¹⁾ The marketing status values are defined as follows:

ACTIVE: Product device recommended for new designs.

LIFEBUY: TI has announced that the device will be discontinued, and a lifetime-buy period is in effect.

NRND: Not recommended for new designs. Device is in production to support existing customers, but TI does not recommend using this part in a new design.

PREVIEW: Device has been announced but is not in production. Samples may or may not be available.

OBSOLETE: TI has discontinued the production of the device.

⁽²⁾ **RoHS:** TI defines "RoHS" to mean semiconductor products that are compliant with the current EU RoHS requirements for all 10 RoHS substances, including the requirement that RoHS substance do not exceed 0.1% by weight in homogeneous materials. Where designed to be soldered at high temperatures, "RoHS" products are suitable for use in specified lead-free processes. TI may reference these types of products as "Pb-Free".

RoHS Exempt: TI defines "RoHS Exempt" to mean products that contain lead but are compliant with EU RoHS pursuant to a specific EU RoHS exemption.

Green: TI defines "Green" to mean the content of Chlorine (Cl) and Bromine (Br) based flame retardants meet JS709B low halogen requirements of <=1000ppm threshold. Antimony trioxide based flame retardants must also meet the <=1000ppm threshold requirement.

⁽³⁾ MSL, Peak Temp. - The Moisture Sensitivity Level rating according to the JEDEC industry standard classifications, and peak solder temperature.

- (4) There may be additional marking, which relates to the logo, the lot trace code information, or the environmental category on the device.
- (5) Multiple Device Markings will be inside parentheses. Only one Device Marking contained in parentheses and separated by a "-" will appear on a device. If a line is indented then it is a continuation of the previous line and the two combined represent the entire Device Marking for that device.
- (6) Lead/Ball Finish - Orderable Devices may have multiple material finish options. Finish options are separated by a vertical ruled line. Lead/Ball Finish values may wrap to two lines if the finish value exceeds the maximum column width.

Important Information and Disclaimer: The information provided on this page represents TI's knowledge and belief as of the date that it is provided. TI bases its knowledge and belief on information provided by third parties, and makes no representation or warranty as to the accuracy of such information. Efforts are underway to better integrate information from third parties. TI has taken and continues to take reasonable steps to provide representative and accurate information but may not have conducted destructive testing or chemical analysis on incoming materials and chemicals. TI and TI suppliers consider certain information to be proprietary, and thus CAS numbers and other limited information may not be available for release.

In no event shall TI's liability arising out of such information exceed the total purchase price of the TI part(s) at issue in this document sold by TI to Customer on an annual basis.

OTHER QUALIFIED VERSIONS OF SN5400, SN54LS00, SN54LS00-SP, SN54S00, SN7400, SN74LS00, SN74S00 :

- Catalog: SN7400, SN74LS00, SN54LS00, SN74S00
- Military: SN5400, SN54LS00, SN54S00
- Space: SN54LS00-SP

NOTE: Qualified Version Definitions:

- Catalog - TI's standard catalog product
- Military - QML certified for Military and Defense Applications
- Space - Radiation tolerant, ceramic packaging and qualified for use in Space-based application

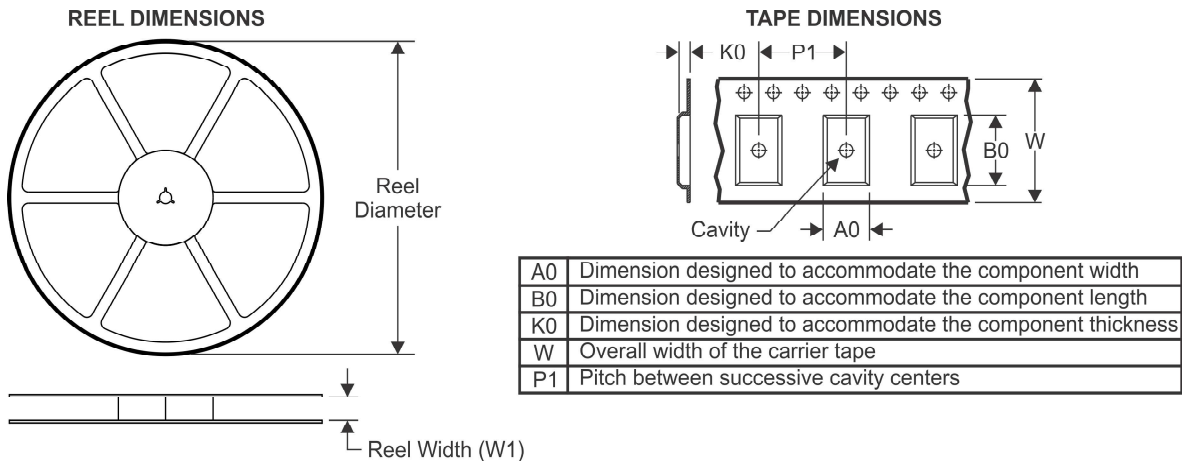
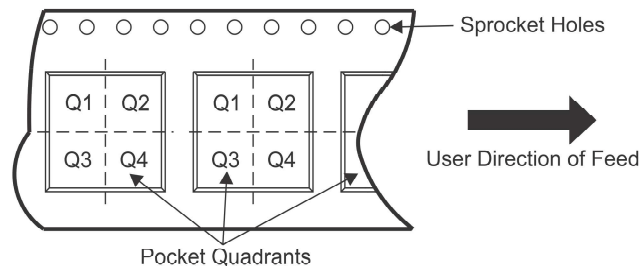
TAPE AND REEL INFORMATION

QUADRANT ASSIGNMENTS FOR PIN 1 ORIENTATION IN TAPE

*All dimensions are nominal

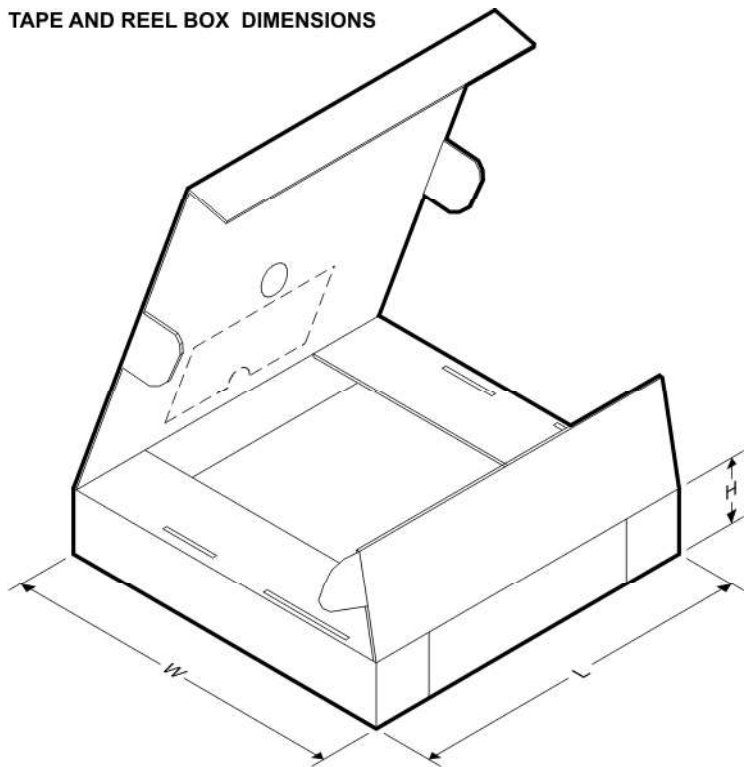
| Device | Package Type | Package Drawing | Pins | SPQ | Reel Diameter (mm) | Reel Width W1 (mm) | A0 (mm) | B0 (mm) | K0 (mm) | P1 (mm) | W (mm) | Pin1 Quadrant |
|-------------|--------------|-----------------|------|------|--------------------|--------------------|---------|---------|---------|---------|--------|---------------|
| SN74LS00DBR | SSOP | DB | 14 | 2000 | 330.0 | 16.4 | 8.2 | 6.6 | 2.5 | 12.0 | 16.0 | Q1 |
| SN74LS00DR | SOIC | D | 14 | 2500 | 330.0 | 16.4 | 6.5 | 9.0 | 2.1 | 8.0 | 16.0 | Q1 |
| SN74LS00NSR | SO | NS | 14 | 2000 | 330.0 | 16.4 | 8.2 | 10.5 | 2.5 | 12.0 | 16.0 | Q1 |
| SN74LS00PSR | SO | PS | 8 | 2000 | 330.0 | 16.4 | 8.2 | 6.6 | 2.5 | 12.0 | 16.0 | Q1 |

TAPE AND REEL BOX DIMENSIONS

*All dimensions are nominal

| Device | Package Type | Package Drawing | Pins | SPQ | Length (mm) | Width (mm) | Height (mm) |
|-------------|--------------|-----------------|------|------|-------------|------------|-------------|
| SN74LS00DBR | SSOP | DB | 14 | 2000 | 367.0 | 367.0 | 38.0 |
| SN74LS00DR | SOIC | D | 14 | 2500 | 367.0 | 367.0 | 38.0 |
| SN74LS00NSR | SO | NS | 14 | 2000 | 367.0 | 367.0 | 38.0 |
| SN74LS00PSR | SO | PS | 8 | 2000 | 367.0 | 367.0 | 38.0 |

FK (S-CQCC-N**)

LEADLESS CERAMIC CHIP CARRIER

28 TERMINAL SHOWN

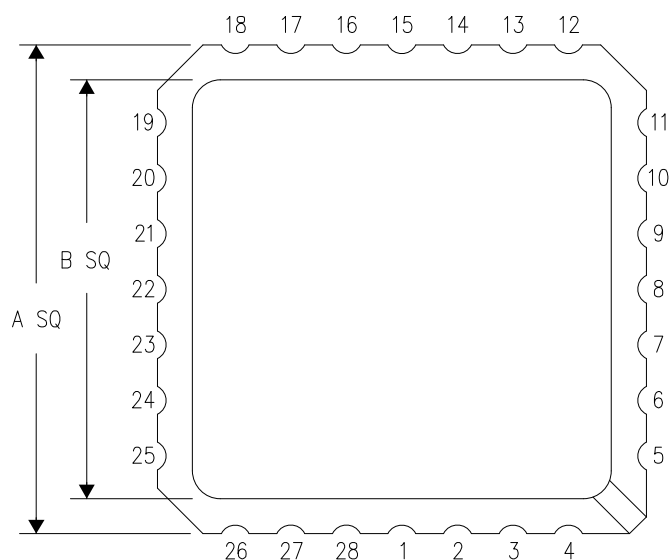

| NO. OF TERMINALS ** | A | | B | |
|---------------------|------------------|------------------|------------------|------------------|
| | MIN | MAX | MIN | MAX |
| 20 | 0.342 (8,69) | 0.358 (9,09) | 0.307 (7,80) | 0.358 (9,09) |
| 28 | 0.442 (11,23) | 0.458 (11,63) | 0.406 (10,31) | 0.458 (11,63) |
| 44 | 0.640 (16,26) | 0.660 (16,76) | 0.495 (12,58) | 0.560 (14,22) |
| 52 | 0.740 (18,78) | 0.761 (19,32) | 0.495 (12,58) | 0.560 (14,22) |
| 68 | 0.938 (23,83) | 0.962 (24,43) | 0.850 (21,6) | 0.858 (21,8) |
| 84 | 1.141 (28,99) | 1.165 (29,59) | 1.047 (26,6) | 1.063 (27,0) |

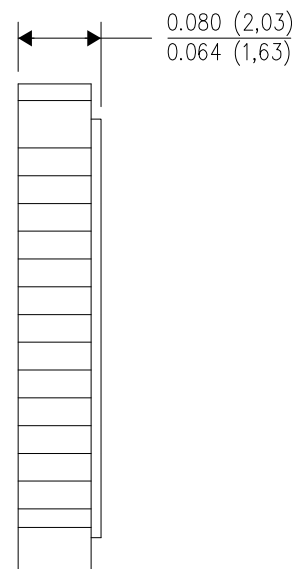
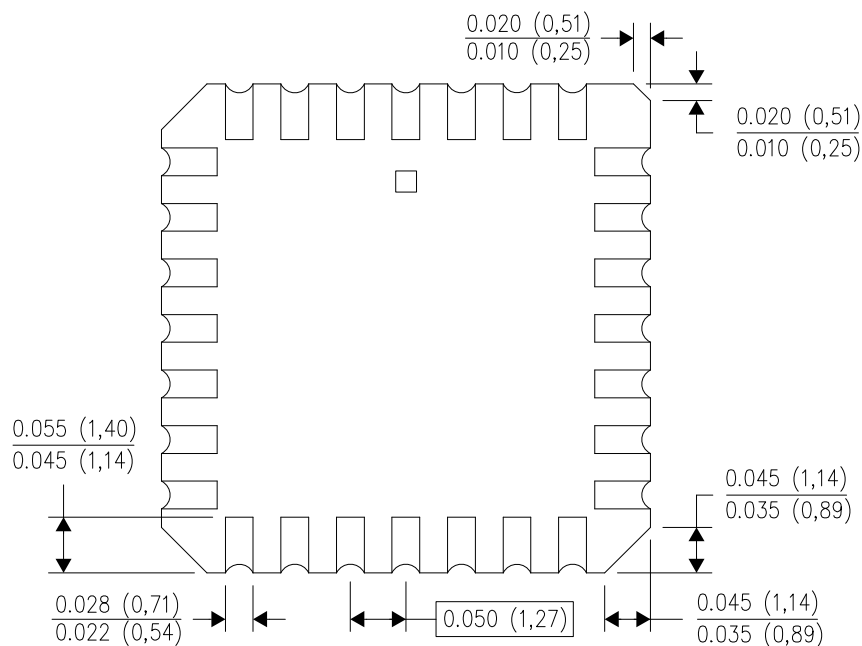

4040140/D 01/11

- NOTES:
- All linear dimensions are in inches (millimeters).
 - This drawing is subject to change without notice.
 - This package can be hermetically sealed with a metal lid.
 - Falls within JEDEC MS-004

MECHANICAL DATA

NS (R-PDSO-G**)

PLASTIC SMALL-OUTLINE PACKAGE

14-PINS SHOWN

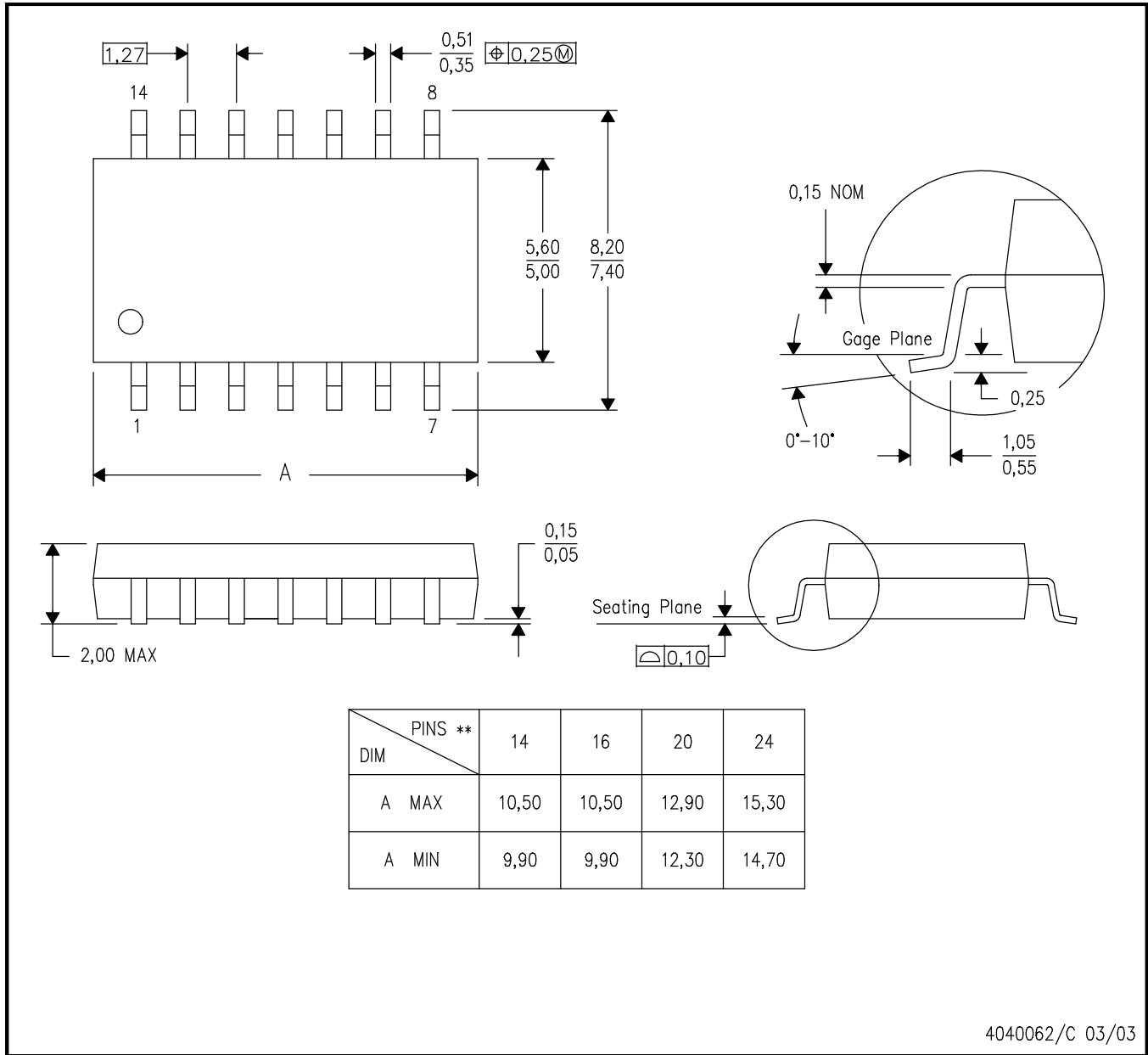

- NOTES:
- A. All linear dimensions are in millimeters.
 - B. This drawing is subject to change without notice.
 - C. Body dimensions do not include mold flash or protrusion, not to exceed 0,15.

J 14

GENERIC PACKAGE VIEW
CDIP - 5.08 mm max height
CERAMIC DUAL IN LINE PACKAGE

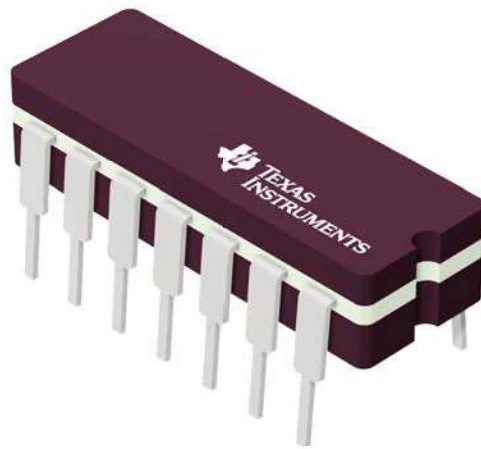

Images above are just a representation of the package family, actual package may vary.
Refer to the product data sheet for package details.

4040083-5/G

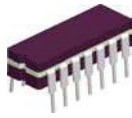

J0014A

PACKAGE OUTLINE

CDIP - 5.08 mm max height

CERAMIC DUAL IN LINE PACKAGE

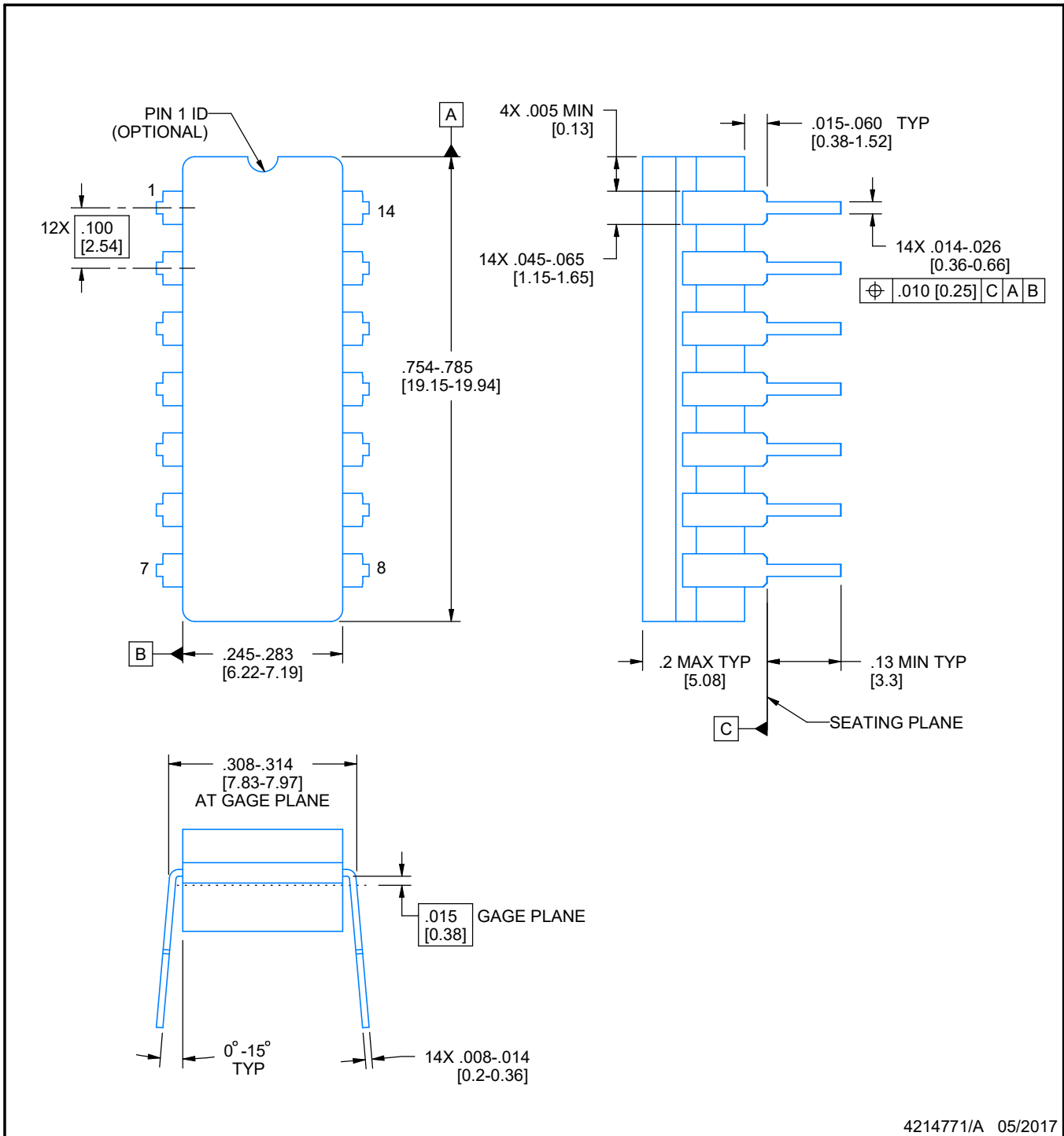

4214771/A 05/2017

NOTES:

1. All controlling linear dimensions are in inches. Dimensions in brackets are in millimeters. Any dimension in brackets or parenthesis are for reference only. Dimensioning and tolerancing per ASME Y14.5M.
2. This drawing is subject to change without notice.
3. This package is hermetically sealed with a ceramic lid using glass frit.
4. Index point is provided on cap for terminal identification only and on press ceramic glass frit seal only.
5. Falls within MIL-STD-1835 and GDIP1-T14.

EXAMPLE BOARD LAYOUT

J0014A

CDIP - 5.08 mm max height

CERAMIC DUAL IN LINE PACKAGE

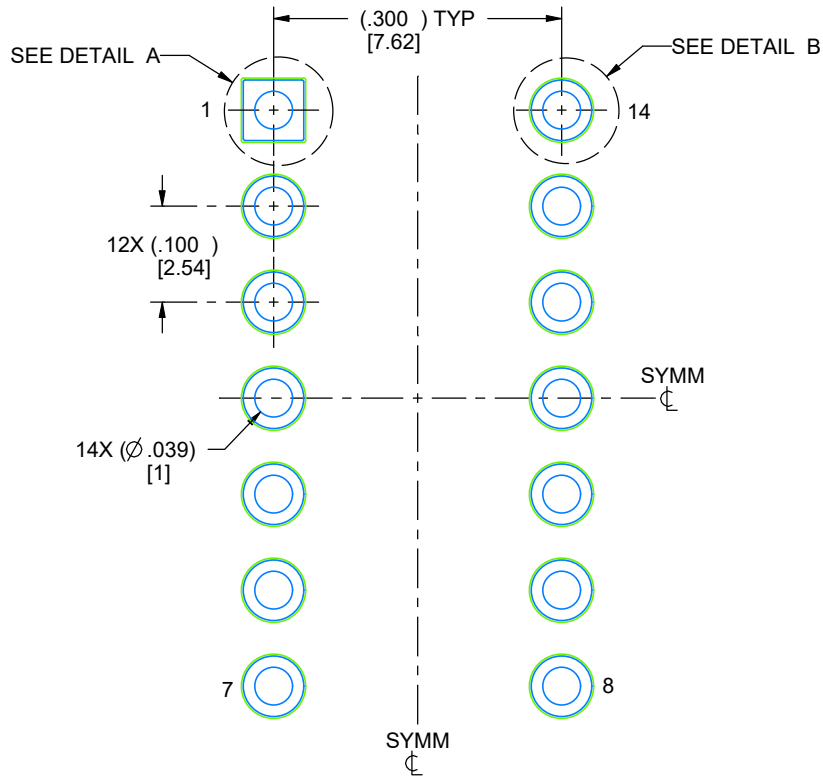

LAND PATTERN EXAMPLE
NON-SOLDER MASK DEFINED
SCALE: 5X

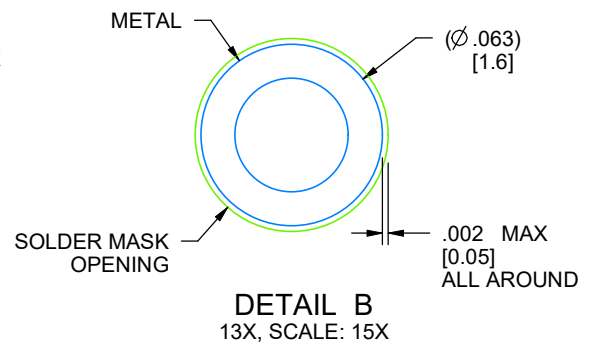
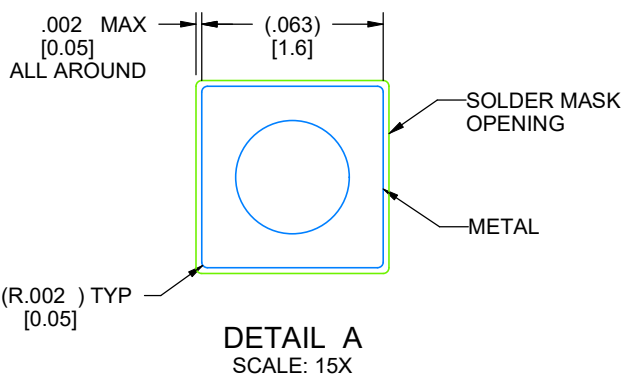



4214771/A 05/2017

D (R-PDSO-G14)

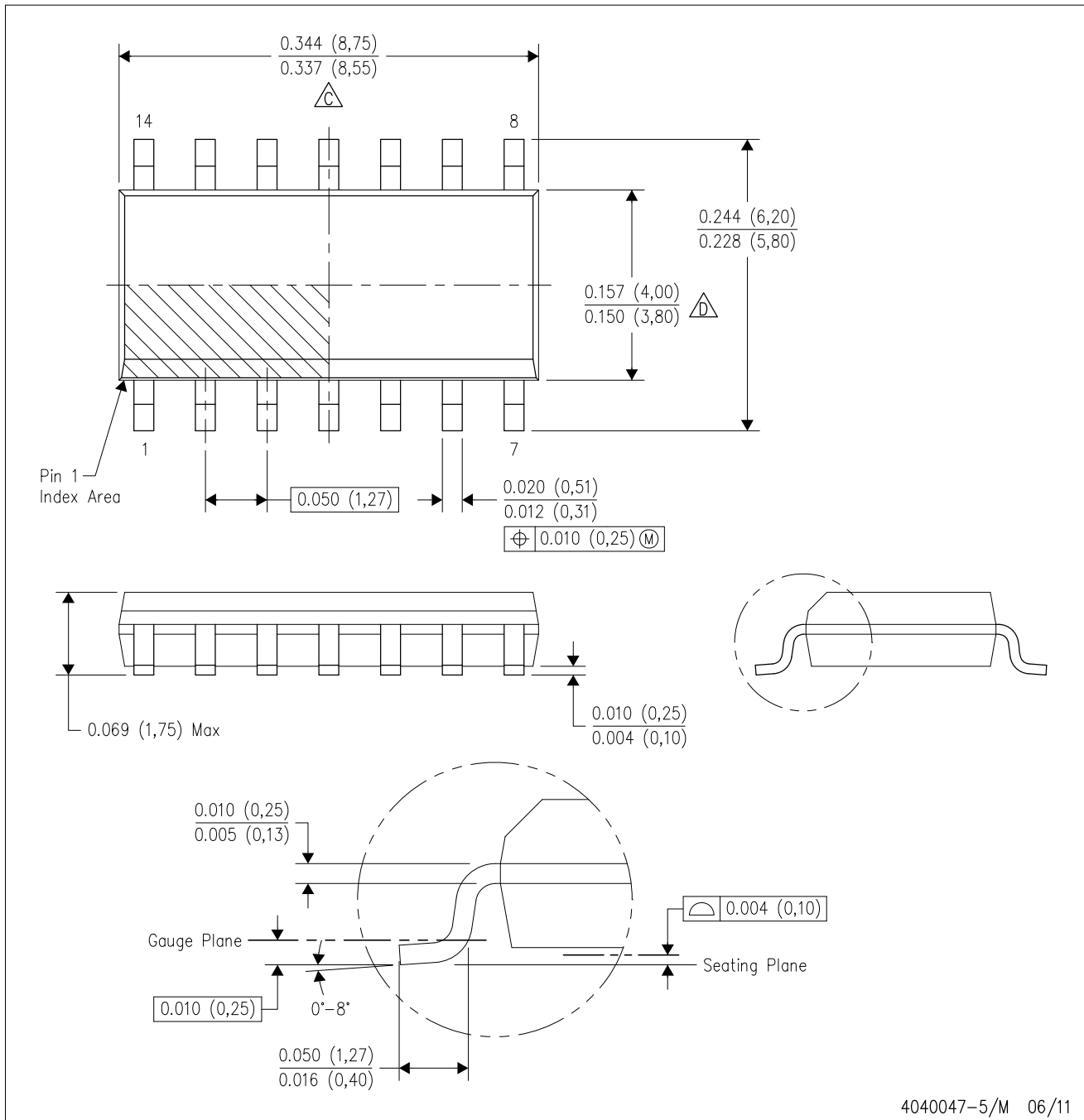
PLASTIC SMALL OUTLINE



- NOTES:
- A. All linear dimensions are in inches (millimeters).
 - B. This drawing is subject to change without notice.
 -  Body length does not include mold flash, protrusions, or gate burrs. Mold flash, protrusions, or gate burrs shall not exceed 0.006 (0,15) each side.
 -  Body width does not include interlead flash. Interlead flash shall not exceed 0.017 (0,43) each side.
 - E. Reference JEDEC MS-012 variation AB.

D (R-PDSO-G14)

PLASTIC SMALL OUTLINE

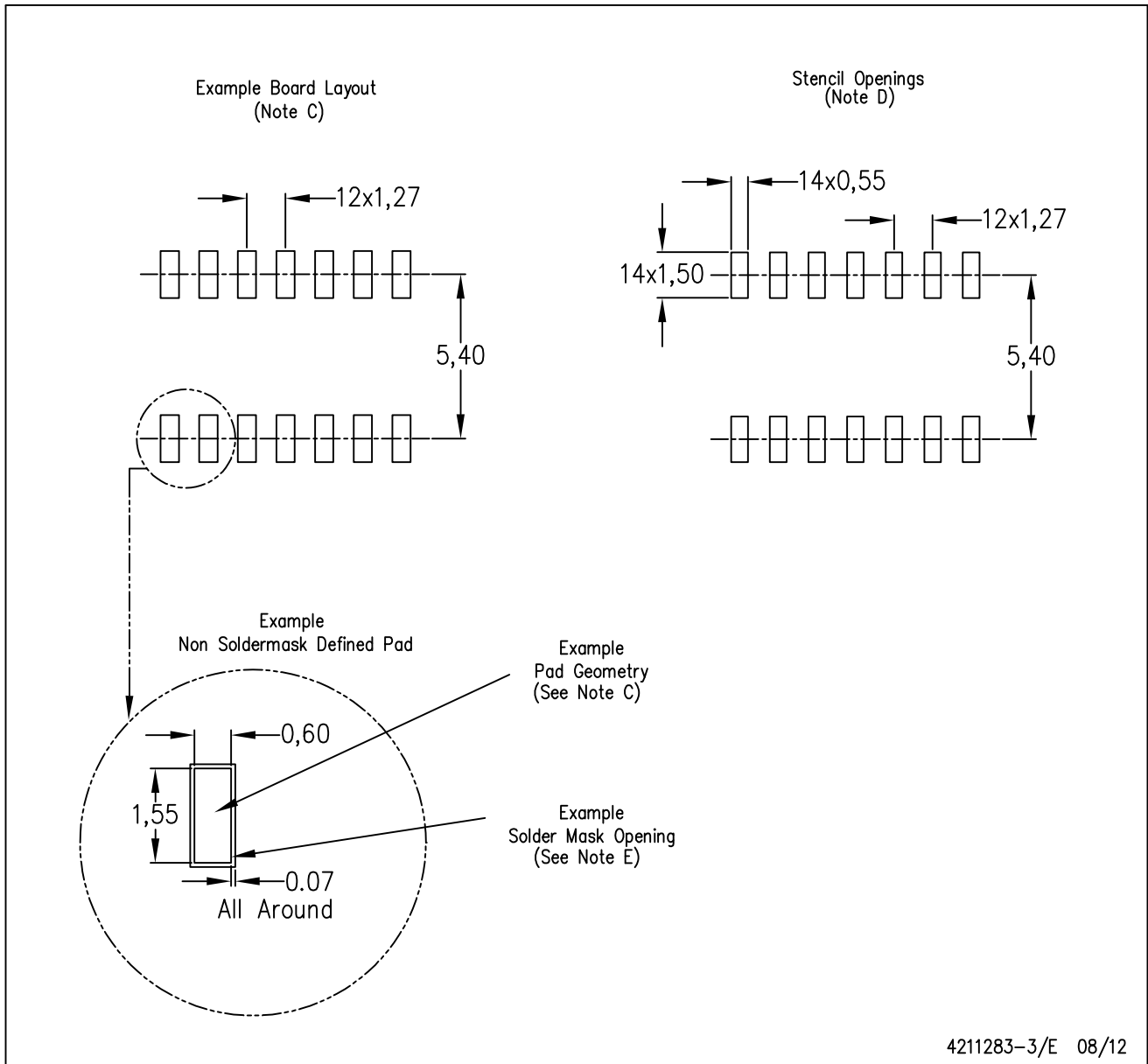

- NOTES:
- A. All linear dimensions are in millimeters.
 - B. This drawing is subject to change without notice.
 - C. Publication IPC-7351 is recommended for alternate designs.
 - D. Laser cutting apertures with trapezoidal walls and also rounding corners will offer better paste release. Customers should contact their board assembly site for stencil design recommendations. Refer to IPC-7525 for other stencil recommendations.
 - E. Customers should contact their board fabrication site for solder mask tolerances between and around signal pads.

MECHANICAL DATA

PS (R-PDSO-G8)

PLASTIC SMALL-OUTLINE PACKAGE

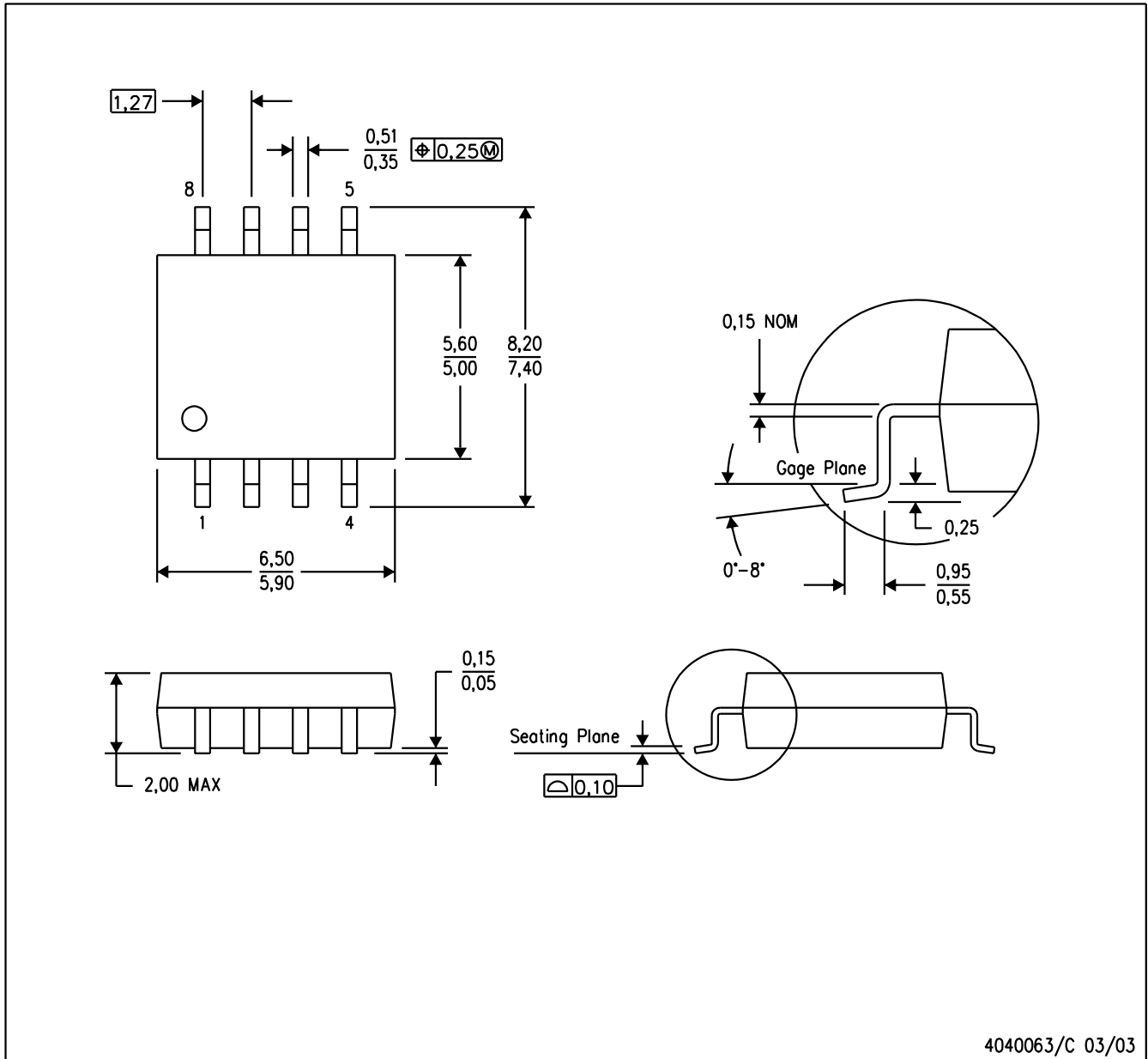

- NOTES:
- A. All linear dimensions are in millimeters.
 - B. This drawing is subject to change without notice.
 - C. Body dimensions do not include mold flash or protrusion, not to exceed 0,15.

PS (R-PDSO-G8)

PLASTIC SMALL OUTLINE

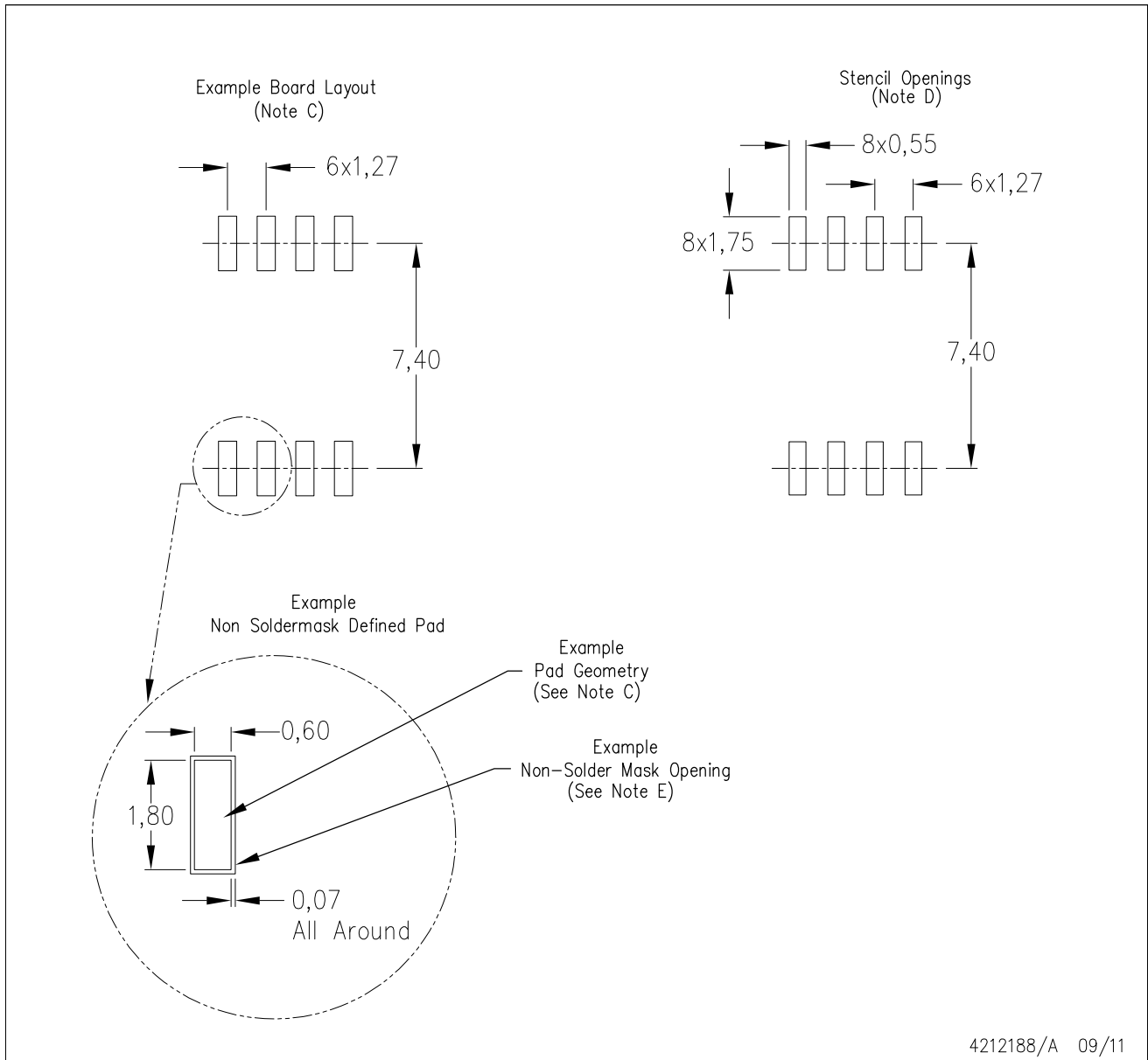



- NOTES:
- All linear dimensions are in millimeters.
 - This drawing is subject to change without notice.
 - Publication IPC-7351 is recommended for alternate designs.
 - Laser cutting apertures with trapezoidal walls and also rounding corners will offer better paste release. Customers should contact their board assembly site for stencil design recommendations. Refer to IPC-7525 for other stencil recommendations.
 - Customers should contact their board fabrication site for solder mask tolerances between and around signal pads.

N (R-PDIP-T**)

PLASTIC DUAL-IN-LINE PACKAGE

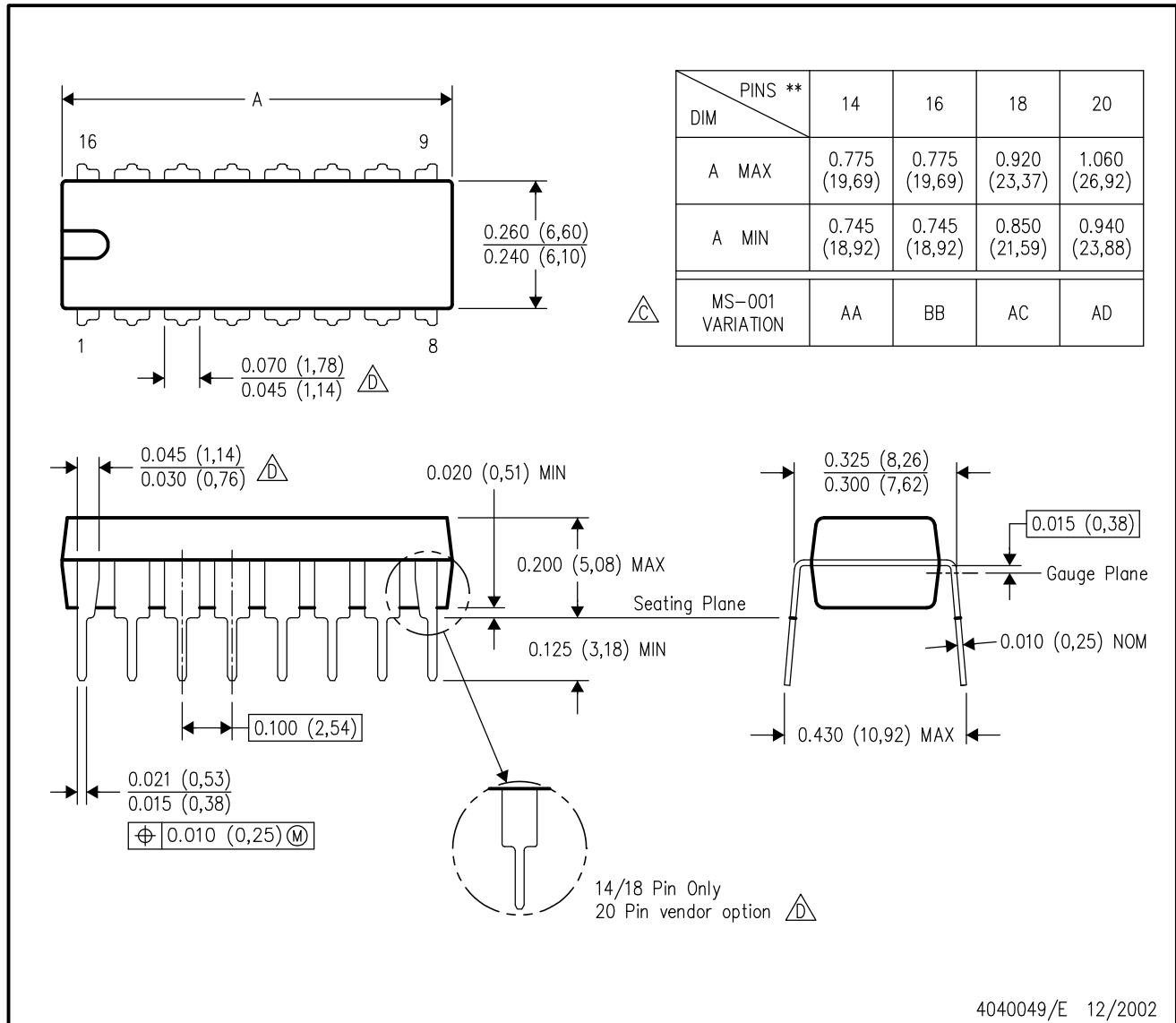
16 PINS SHOWN



- NOTES:
- A. All linear dimensions are in inches (millimeters).
 - B. This drawing is subject to change without notice.
 -  Falls within JEDEC MS-001, except 18 and 20 pin minimum body length (Dim A).
 -  The 20 pin end lead shoulder width is a vendor option, either half or full width.

DB (R-PDSO-G**)

PLASTIC SMALL-OUTLINE

28 PINS SHOWN

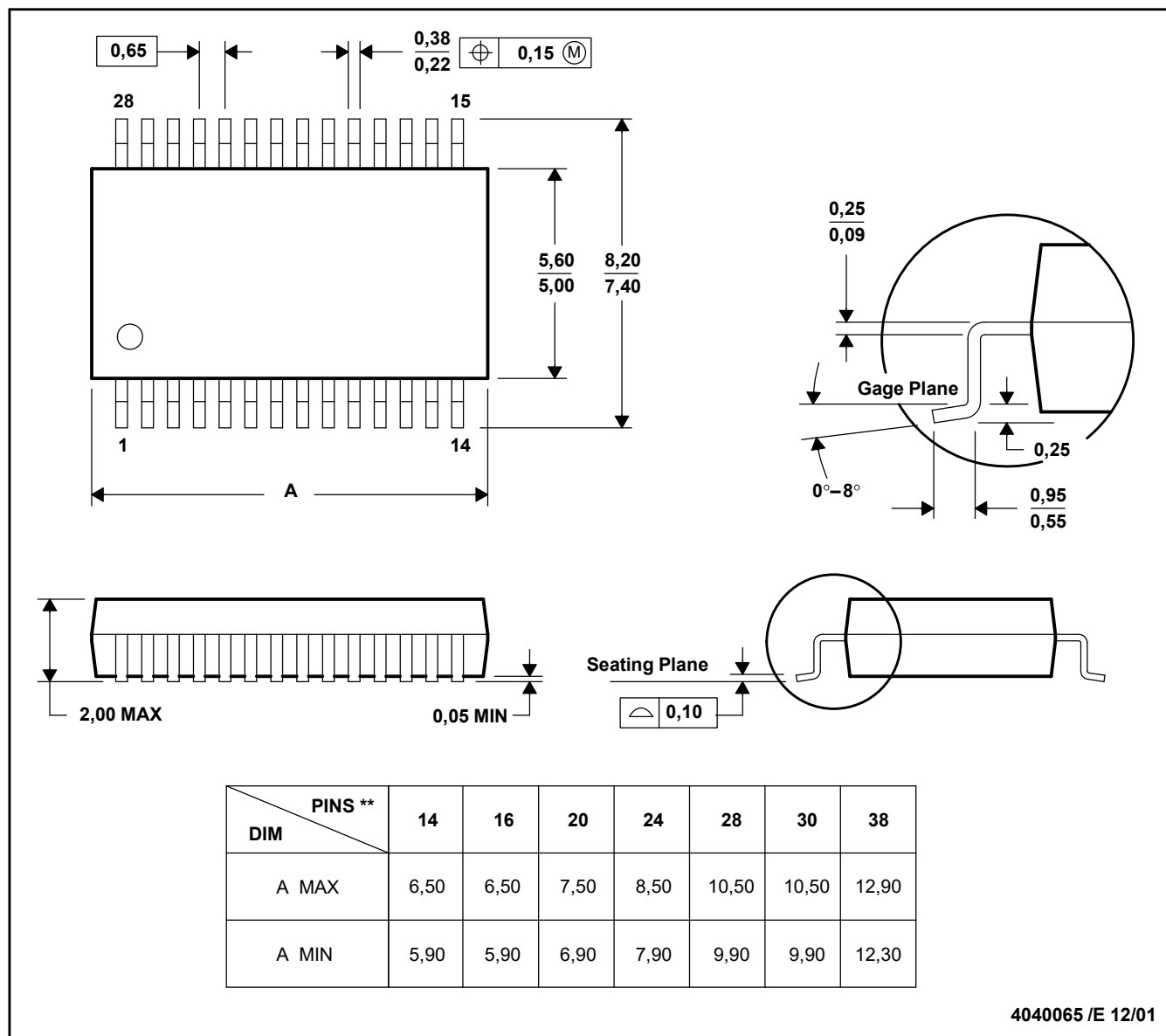

- NOTES: A. All linear dimensions are in millimeters.
 B. This drawing is subject to change without notice.
 C. Body dimensions do not include mold flash or protrusion not to exceed 0,15.
 D. Falls within JEDEC MO-150

W (R-GDFP-F14)

CERAMIC DUAL FLATPACK

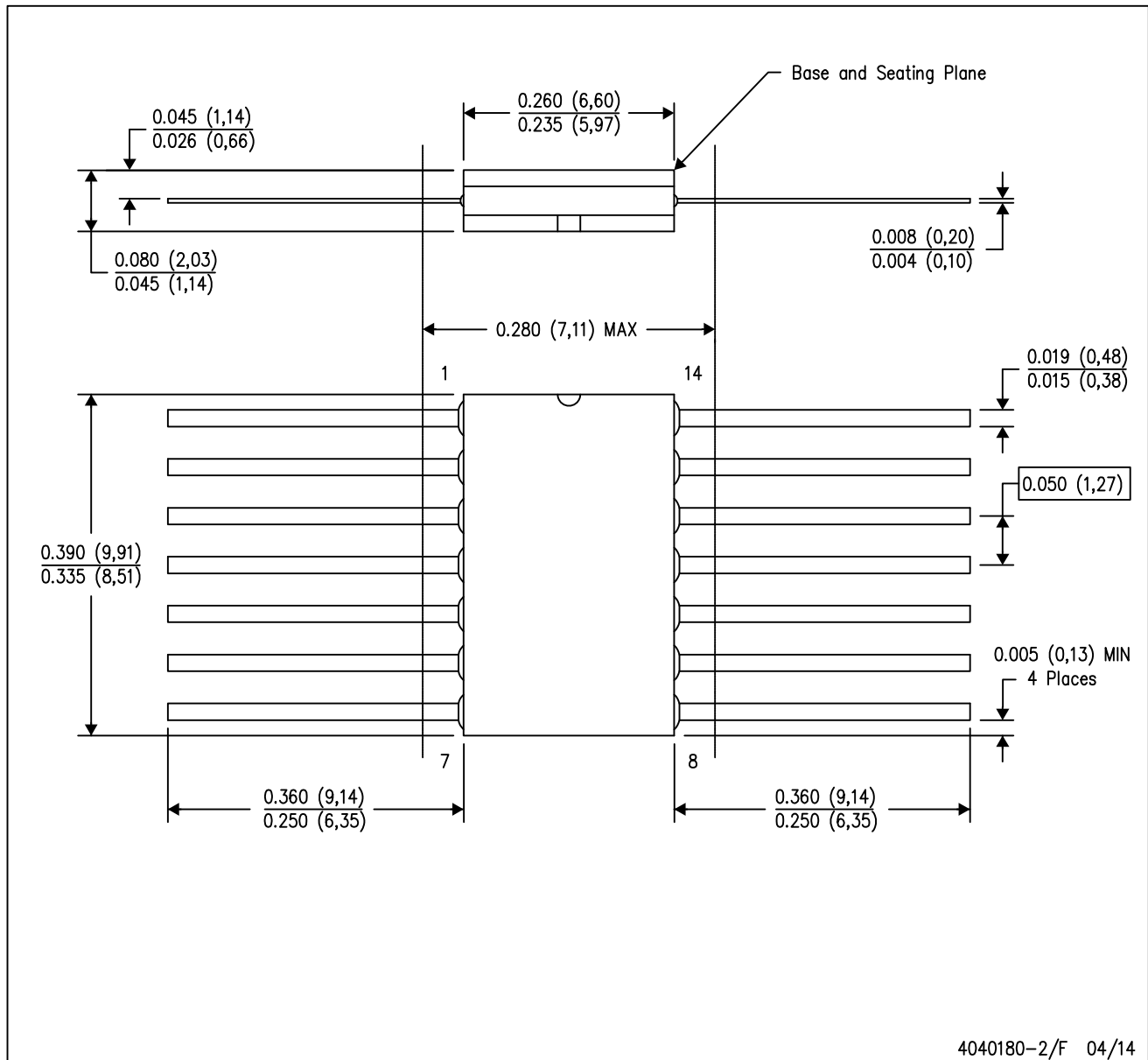

4040180-2/F 04/14

- NOTES:
- A. All linear dimensions are in inches (millimeters).
 - B. This drawing is subject to change without notice.
 - C. This package can be hermetically sealed with a ceramic lid using glass frit.
 - D. Index point is provided on cap for terminal identification only.
 - E. Falls within MIL STD 1835 GDFP1-F14

IMPORTANT NOTICE

Texas Instruments Incorporated (TI) reserves the right to make corrections, enhancements, improvements and other changes to its semiconductor products and services per JESD46, latest issue, and to discontinue any product or service per JESD48, latest issue. Buyers should obtain the latest relevant information before placing orders and should verify that such information is current and complete.

TI's published terms of sale for semiconductor products (<http://www.ti.com/sc/docs/stdterms.htm>) apply to the sale of packaged integrated circuit products that TI has qualified and released to market. Additional terms may apply to the use or sale of other types of TI products and services.

Reproduction of significant portions of TI information in TI data sheets is permissible only if reproduction is without alteration and is accompanied by all associated warranties, conditions, limitations, and notices. TI is not responsible or liable for such reproduced documentation. Information of third parties may be subject to additional restrictions. Resale of TI products or services with statements different from or beyond the parameters stated by TI for that product or service voids all express and any implied warranties for the associated TI product or service and is an unfair and deceptive business practice. TI is not responsible or liable for any such statements.

Buyers and others who are developing systems that incorporate TI products (collectively, "Designers") understand and agree that Designers remain responsible for using their independent analysis, evaluation and judgment in designing their applications and that Designers have full and exclusive responsibility to assure the safety of Designers' applications and compliance of their applications (and of all TI products used in or for Designers' applications) with all applicable regulations, laws and other applicable requirements. Designer represents that, with respect to their applications, Designer has all the necessary expertise to create and implement safeguards that (1) anticipate dangerous consequences of failures, (2) monitor failures and their consequences, and (3) lessen the likelihood of failures that might cause harm and take appropriate actions. Designer agrees that prior to using or distributing any applications that include TI products, Designer will thoroughly test such applications and the functionality of such TI products as used in such applications.

TI's provision of technical, application or other design advice, quality characterization, reliability data or other services or information, including, but not limited to, reference designs and materials relating to evaluation modules, (collectively, "TI Resources") are intended to assist designers who are developing applications that incorporate TI products; by downloading, accessing or using TI Resources in any way, Designer (individually or, if Designer is acting on behalf of a company, Designer's company) agrees to use any particular TI Resource solely for this purpose and subject to the terms of this Notice.

TI's provision of TI Resources does not expand or otherwise alter TI's applicable published warranties or warranty disclaimers for TI products, and no additional obligations or liabilities arise from TI providing such TI Resources. TI reserves the right to make corrections, enhancements, improvements and other changes to its TI Resources. TI has not conducted any testing other than that specifically described in the published documentation for a particular TI Resource.

Designer is authorized to use, copy and modify any individual TI Resource only in connection with the development of applications that include the TI product(s) identified in such TI Resource. NO OTHER LICENSE, EXPRESS OR IMPLIED, BY ESTOPPEL OR OTHERWISE TO ANY OTHER TI INTELLECTUAL PROPERTY RIGHT, AND NO LICENSE TO ANY TECHNOLOGY OR INTELLECTUAL PROPERTY RIGHT OF TI OR ANY THIRD PARTY IS GRANTED HEREIN, including but not limited to any patent right, copyright, mask work right, or other intellectual property right relating to any combination, machine, or process in which TI products or services are used. Information regarding or referencing third-party products or services does not constitute a license to use such products or services, or a warranty or endorsement thereof. Use of TI Resources may require a license from a third party under the patents or other intellectual property of the third party, or a license from TI under the patents or other intellectual property of TI.

TI RESOURCES ARE PROVIDED "AS IS" AND WITH ALL FAULTS. TI DISCLAIMS ALL OTHER WARRANTIES OR REPRESENTATIONS, EXPRESS OR IMPLIED, REGARDING RESOURCES OR USE THEREOF, INCLUDING BUT NOT LIMITED TO ACCURACY OR COMPLETENESS, TITLE, ANY EPIDEMIC FAILURE WARRANTY AND ANY IMPLIED WARRANTIES OF MERCHANTABILITY, FITNESS FOR A PARTICULAR PURPOSE, AND NON-INFRINGEMENT OF ANY THIRD PARTY INTELLECTUAL PROPERTY RIGHTS. TI SHALL NOT BE LIABLE FOR AND SHALL NOT DEFEND OR INDEMNIFY DESIGNER AGAINST ANY CLAIM, INCLUDING BUT NOT LIMITED TO ANY INFRINGEMENT CLAIM THAT RELATES TO OR IS BASED ON ANY COMBINATION OF PRODUCTS EVEN IF DESCRIBED IN TI RESOURCES OR OTHERWISE. IN NO EVENT SHALL TI BE LIABLE FOR ANY ACTUAL, DIRECT, SPECIAL, COLLATERAL, INDIRECT, PUNITIVE, INCIDENTAL, CONSEQUENTIAL OR EXEMPLARY DAMAGES IN CONNECTION WITH OR ARISING OUT OF TI RESOURCES OR USE THEREOF, AND REGARDLESS OF WHETHER TI HAS BEEN ADVISED OF THE POSSIBILITY OF SUCH DAMAGES.

Unless TI has explicitly designated an individual product as meeting the requirements of a particular industry standard (e.g., ISO/TS 16949 and ISO 26262), TI is not responsible for any failure to meet such industry standard requirements.

Where TI specifically promotes products as facilitating functional safety or as compliant with industry functional safety standards, such products are intended to help enable customers to design and create their own applications that meet applicable functional safety standards and requirements. Using products in an application does not by itself establish any safety features in the application. Designers must ensure compliance with safety-related requirements and standards applicable to their applications. Designer may not use any TI products in life-critical medical equipment unless authorized officers of the parties have executed a special contract specifically governing such use. Life-critical medical equipment is medical equipment where failure of such equipment would cause serious bodily injury or death (e.g., life support, pacemakers, defibrillators, heart pumps, neurostimulators, and implantables). Such equipment includes, without limitation, all medical devices identified by the U.S. Food and Drug Administration as Class III devices and equivalent classifications outside the U.S.

TI may expressly designate certain products as completing a particular qualification (e.g., Q100, Military Grade, or Enhanced Product). Designers agree that it has the necessary expertise to select the product with the appropriate qualification designation for their applications and that proper product selection is at Designers' own risk. Designers are solely responsible for compliance with all legal and regulatory requirements in connection with such selection.

Designer will fully indemnify TI and its representatives against any damages, costs, losses, and/or liabilities arising out of Designer's non-compliance with the terms and provisions of this Notice.