

Three Phase sinusoidal BLDC Motor Controller

Description

The FT1128 is a Three Phase sinusoidal Brushless DC (BLDC) Motor controller with a built-in driver. It comes with Hall insensitive sensor design providing both SVPWM and BLDC drive with constant/variable lead angle. Open/Closed loop speed adjustment can be achieved through either direct-PWM or analog voltage, initiated by soft-start. Speed indicator is provided through a Frequency Generator output, generating digital pulse with a configurable frequency proportional to the speed of the motor.

Protection functions of FT1128 are comprehensive including lock protection and automatic recovery, under voltage, thermal shutdown and current limit protections. These prevent the control circuits and the motor from being damaged, particularly under stressed applications and demanding environments.

Feature

- Selectable SVPWM (sine-wave) or BLDC (120°) drives
- Hall sensor/ Hall IC input supported
- 180° sinusoidal drive, for high efficiency and low acoustic noise
- Intelligent Soft-start
- Constant/Variable lead angle control
- Open/Closed loop speed adjustment can be selected (direct-PWM and analog voltage control).
- FG (Frequency Generator)
- Current limit protection
- Over current protection(FT1128Q)
- Built-in lock protection and automatic recovery circuit
- Built-in thermal shutdown protection (TSD)

Block Diagram

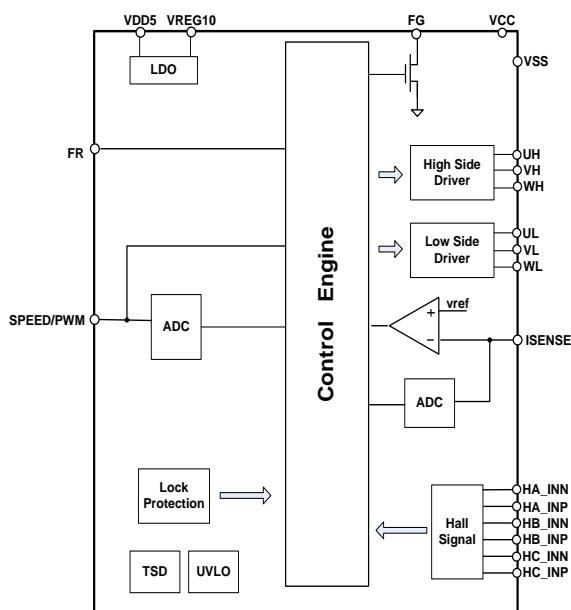

FT1128T Block Diagram

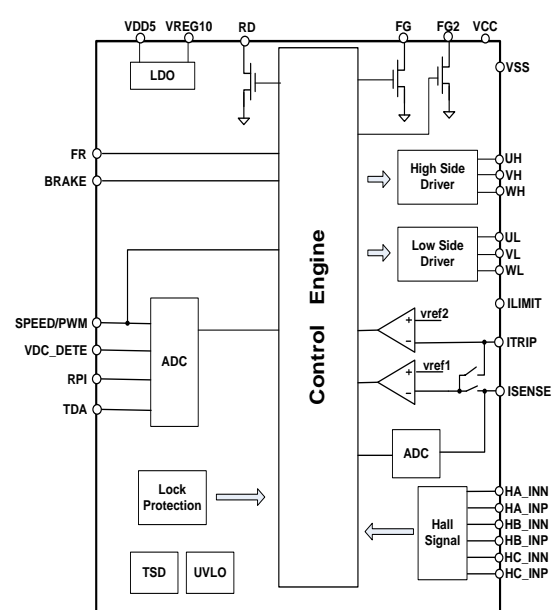

FT1128Q Block Diagram

Pin Assignment

TSSOP20

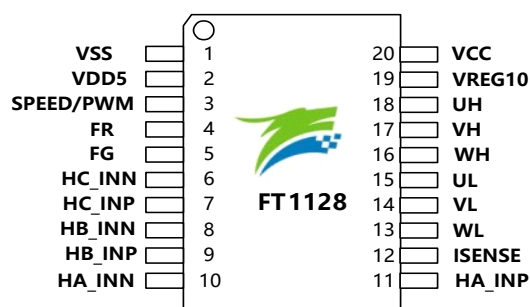

Pin Configuration

PIN NO.	PIN Name	Type	Description
1	VSS	Ground	Signal and power ground.
2	VDD5	O	Digital power output, LDO DC5V output for digital signal.
3	SPEED/PWM	I	Speed control input
4	FR	I	Motor rotation direction input
5	FG	O	Open drain. Frequency Generator, speed signal output.
6	HC_INN	I	Hall C - Sensor Input. Phase-W magnetic field detection.
7	HC_INP	I	Hall C + Sensor Input. Phase-W magnetic field detection.
8	HB_INN	I	Hall B - Sensor Input. Phase-V magnetic field detection.
9	HB_INP	I	Hall B + Sensor Input. Phase-V magnetic field detection.
10	HA_INN	I	Hall A - Sensor Input. Phase-U magnetic field detection.
11	HA_INP	I	Hall A + Sensor Input. Phase-U magnetic field detection.
12	ISENSE	I	Current limit & Lead angle analog input
13	WL	O	Low side phase W NMOS driver
14	VL	O	Low side phase V NMOS driver
15	UL	O	Low side phase U NMOS driver
16	WH	O	High side phase W PMOS driver.
17	VH	O	High side phase V PMOS driver.
18	UH	O	High side phase U PMOS driver.
19	VREG10	O	LDO output
20	VCC	POWER	Power supply

Pin Assignment

QFN28

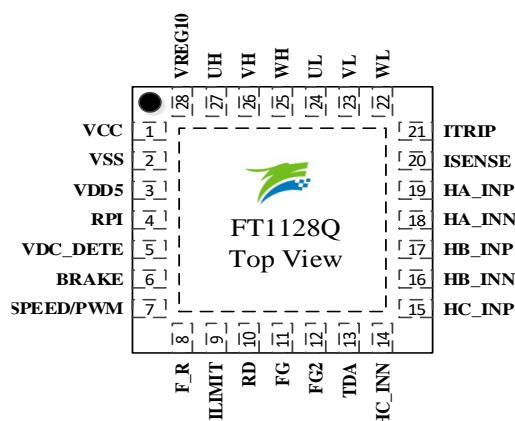

Pin Configuration

PIN NO.	PIN Name	Type	Description
1	VCC	POWER	Power supply
2	VSS	Ground	Signal and power ground.
3	VDD5	O	Digital power output, LDO DC 5V output for digital signal.
4	RPI	I	Soft start duty setting
5	VDC_DETE	I	Power supply over voltage and under voltage detection input
6	BRAKE	I	Brake signal input, Low: Brake. Internal pull-up.
7	SPEED/PWM	I	Speed control input
8	FR	I	Motor rotation direction input
9	ILIMIT	I	Current limit analog input
10	RD	O	Open drain. Motor rotate detection output.
11	FG	O	Open drain. Frequency Generator, speed signal output.
12	FG2	O	Open drain. Frequency Generator, HALL B signal output.
13	TDA	I	Thermal Detection input
14	HC_INN	I	Hall C - Sensor Input. Phase-W magnetic field detection.
15	HC_INP	I	Hall C + Sensor Input. Phase-W magnetic field detection.
16	HB_INN	I	Hall B - Sensor Input. Phase-V magnetic field detection.
17	HB_INP	I	Hall B + Sensor Input. Phase-V magnetic field detection.
18	HA_INN	I	Hall A - Sensor Input. Phase-U magnetic field detection.
19	HA_INP	I	Hall A + Sensor Input. Phase-U magnetic field detection.
20	ISENSE	I	Current limit & Lead angle analog input
21	ITRIP	I	Current limit & over current protection input pin
22	WL	O	Low side phase W NMOS driver
23	VL	O	Low side phase V NMOS driver
24	UL	O	Low side phase U NMOS driver
25	WH	O	High side phase W PMOS driver.
26	VH	O	High side phase V PMOS driver.
27	UH	O	High side phase U PMOS driver.
28	VREG10	O	LDO output

Absolute Maximum Ratings

Stresses exceeding the absolute maximum ratings may damage the device. The device may be damaged or may not function or be operational above these ratings and stressing the device to/above these levels is not recommended. Fortior does not recommend exceeding or designing about the Absolute Maximum Ratings.

Parameter	Symbol	Condition	Ratings	Unit
Power supply voltage	V_{ccmax}		30.0	V
RDFG output current	$I_{RDFGmax}$		10	mA
RDFG output pin withstand voltage	$V_{RDFGmax}$		5.5	V
Operating temperature	T_{opr}		-40~+125	°C
Storage temperature	T_{stg}		-65~+150	°C

Recommended Operating Conditions

The Recommended Operating Conditions table defines the conditions for actual device operation. Recommended operating conditions are specified to ensure optimal performance to the datasheet specifications.

Symbol	Parameter	Min.	Typ.	Max.	Unit
	V_{cc}	3.7	12	28	V

Electrical Characteristics

For guaranteed specifications and test conditions, consult the Electrical Characteristics.

Unless otherwise specified, $T_a=25^{\circ}\text{C}$, $V_{CC}=12\text{V}$

Parameter	Symbol	Condition	Ratings			Unit
			Min.	Typ.	Max.	
Power supply current	I_{cc}	Working	-	10	15	mA
VDD5 LDO						
Regulator voltage	VDD5		4.9	5	5.1	V
Regulator output current	I_{v5out}	VDD5=5V	-		10	mA
10V Regulator Block						
Regulator voltage	Vreg10		9.5	10.0	10.5	V
Regulator output current	I_{v10out}	Vreg10=10V	-		10	mA
Analog I/O Section*Note1,*2						
Analog Input range			0	-	5.3	V
Hall Input Pin*Note2						
Hall sensor input sensitivity	VHN	Zero peak value (including offset and hysteresis)	-	10	20	mV
Digital Input Section*Note3						
High-level input voltage	Vdinh		2.7	-	5.3	V
Low-level input voltage	Vdinl		0	-	0.9	V
SPEED – PWM DIGITAL MODE						
PWM input frequency	Fpwm		1		80	kHz
HP(High Side PMOS Driver) *Note4						
Output high voltage	HVoh	Sink current = 20mA	11.2	11.5	12	V
Output low voltage	HVol	Source current = 20mA	-	3	5	V
Source Current	I_{o+}		-	150	-	mA
Sink Current	I_{o-}		-	90	-	mA
LN(Low Side NMOS Driver) *Note5						
Output high voltage	LVoh	Sink current = 20mA	8.5	10	11	V
Output low voltage	LVol	Source current = 20mA	-	0	0.3	V
Source Current	I_{o+}		-	150	-	mA
Sink Current	I_{o-}		-	180	-	mA
RD\FG\FG2 Output Pin						
RD\FG output pin low-level voltage	V_{RD_FG}	When $I_o=5\text{mA}$	-	0.1	0.2	V
Thermal Protection Circuit						
Thermal protection circuit operating temperature	TSD		-	150	-	$^{\circ}\text{C}$
Temperature hysteresis width	ΔTSD		-	30	-	$^{\circ}\text{C}$

1.Note1: SPEED、ISENSE、ILIMIT、ITRIP、VDC_DETE、TDA

2. Note2: HA_INN、HA_INP、HB_INN、HB_INP、HC_INN、HC_INP、

3. Note3: FR、PWM.

4. Note4: UH、VH、WH

5. Note5: UL、VL、WL

Functional Description and Notes

Please read the following notes before designing driver circuits with FT1128.

1. Power Up Sequence

Upon powering up of IC, VCC needs to rise to 3V and above within 30ms; Any IO input control sequence must not be connected before VCC is stable.

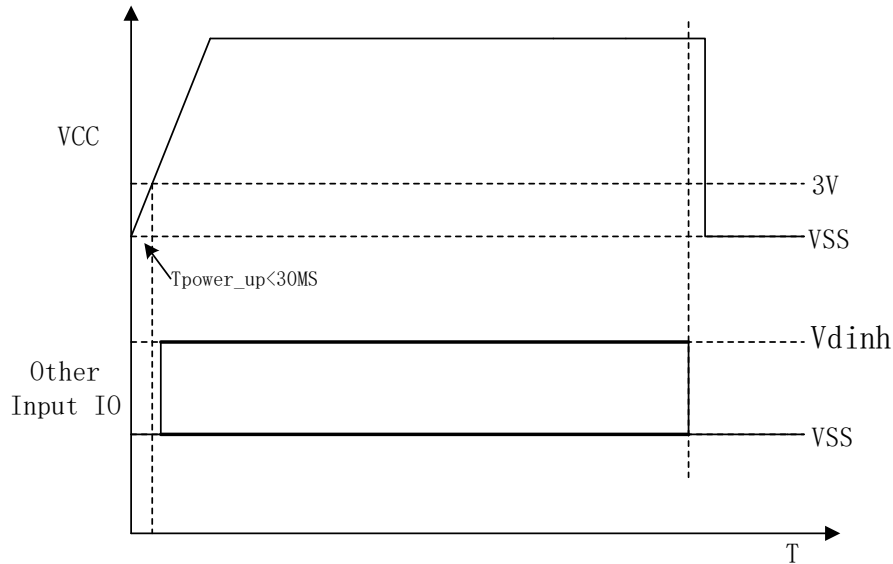

2. Frequency Generator

The Frequency Generator output generates a rotation pulse providing information about the speed of motor. It can be programmed using internal efuse to give 2 mechanical rotation for motor pole pairs ranging from 2-8, or 1-3 per electrical rotation. The default setting is 1 pulse per electrical degree. The FG pin is an open drain output, which is to be connected to a logical voltage level through an external pull-up resistor when used. This pin can be left open if unused.

3. Differential Hall Signal

HA_INN \ HA_INP \ HB_INN \ HB_INP \ HC_INN \ HC_INP are the differential Hall sensor inputs from the assembled motor and must be proportionately stepped down to less than VDD5 for IC protection. HA_INP \ HB_INP \ HC_INP are the Hall IC inputs from the assembled motor, if Hall ICs are used. HA_INN \ HB_INN \ HC_INN is to be connected to ground for HALL IC applications.

4. Hall insensitive mode

User can select Hall insensitive mode. Under this mode, the drive is insensitive to and compensate for the unbalances in the hall signals. It can also be configured such that optimally detected hall edge can be used as reference.

5. SVPWM Mode and BLDC Mode

FT1128 can run in SVPWM mode for motor control. Under SVPWM mode, the phase currents are sinusoidal for acoustic noise reduction. The corresponding sequence diagram is shown in Figure 1.

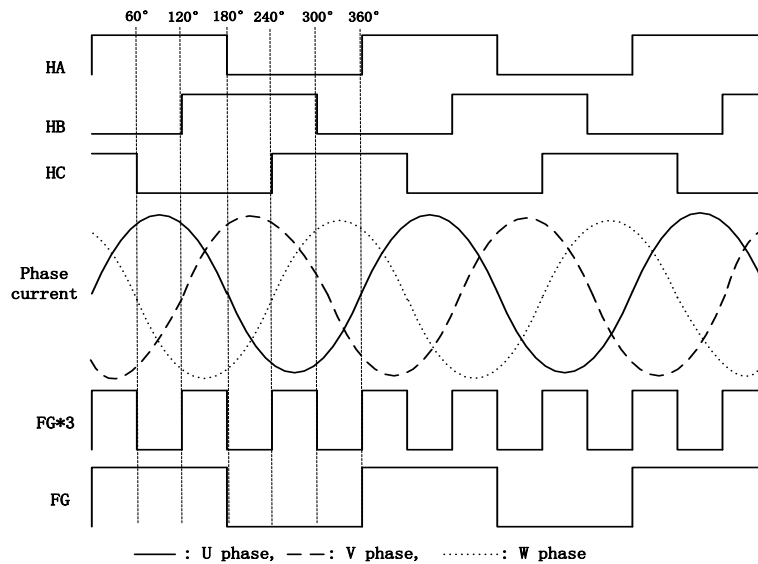

Figure 1 Sequence diagram for 3 Hall

FT1128 can also be programmed to drive the motor with the traditional BLDC (120°) mode. The voltage and current sequence diagram is shown in Figure 2.

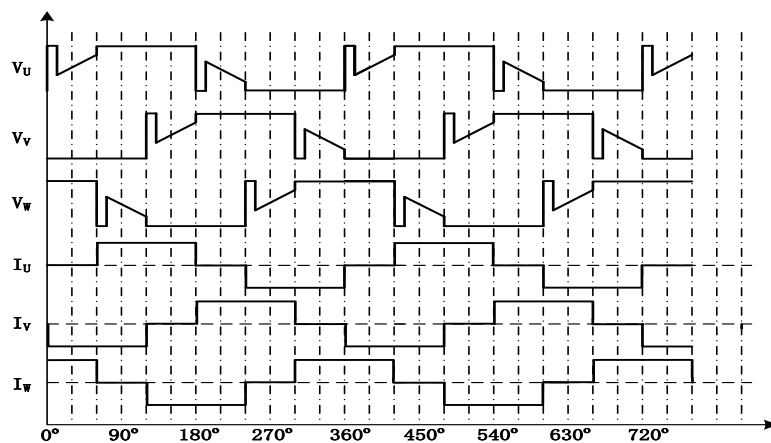

Figure 2 Voltage and Current of BLDC(120°)

6. Setting of Function

Many functions can be set by programming efuses within the chip. These functions include: selection of SVPWM (sine-wave) or BLDC (120°) modulation mode, selection of current protection, selection of open loop speed control or close loop speed control etc.

7. Speed Control Methods

FT1128 has two methods to control speed, through direct digital PWM input or analog voltage input. If digital PWM input is used, PWM input duty direct input to control speed. If analog voltage speed control is used, the voltage seen at SPEED will generate an internal PWM with its duty cycle determined by the following equation:

$$Duty_cycle = \frac{V_{SPEED} - 0.5}{4}$$

The selection of digital PWM input control or analog voltage is done through efuse.

8. Intelligent Soft-start

FT1128 can be started with soft-start as configured by efuse. Under open loop PWM control, the motor is started with initial starting PWM duty and subsequently increased/reduced to the input PWM duty cycle after a configurable number of softstart cycles. However, in the event of rotation at start, to avoid VCC overshoot, FT1128 will bypass the initial starting PWM duty stage and connect the input PWM straight to the output.

9. Closed loop speed control

Closed loop speed control can be is controlled through the duty cycle of the digital input PWM or the voltage level of the analog input PWM. Additional efuses (VLOW and VRANGE) together with SMIN_DUTY can be set in order to achieve the speed profiles. This is achieved using an internal PI loop with its proportional and integral gains configurable through efuses.

10. Lead Angle Correction

The lead angle of generated motor driving signals relative to the Hall signals can be shifted by an angle between 0 and 63 degrees. The lead angle control can be achieved by directly applying a voltage to the ISENSE pin or fixing the efuse. The control of the lead angle by analog voltage input control or fixing efuse is programmed by efuse.

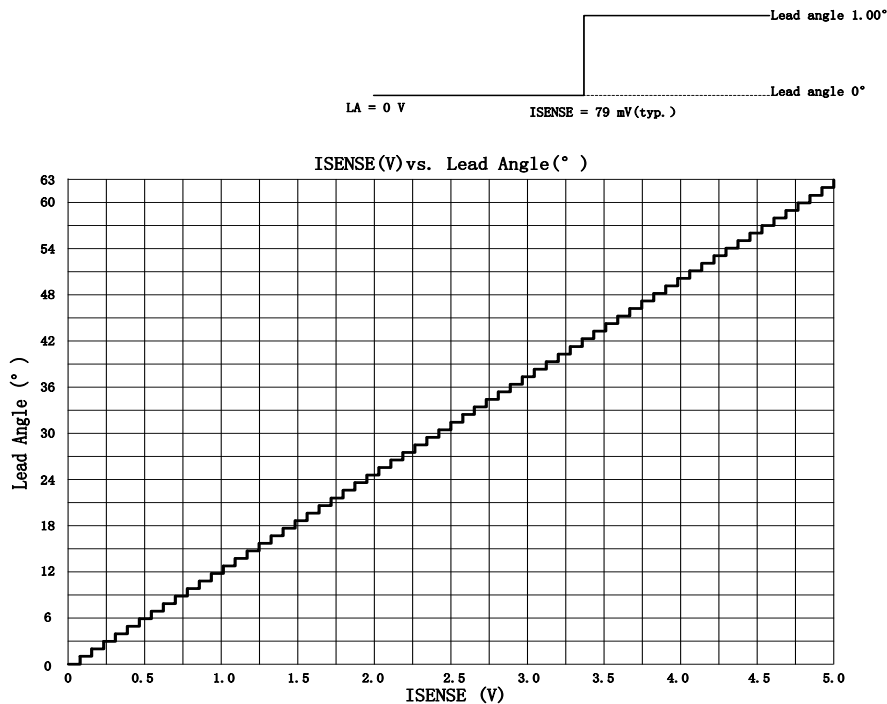

Figure 3 ISENSE Vs Lead Angle

<Typical Characteristics of the ISENSE versus Lead Angle>

Step	ISENSE (V)	Lead angle(°)	Step	ISENSE(V)	Lead angle(°)	Step	ISENSE (V)	Lead angle(°)
0	0.00	0.00	22	1.75	22.00	44	3.49	44.00
1	0.08	1.00	23	1.83	23.00	45	3.57	45.00
2	0.16	2.00	24	1.90	24.00	46	3.65	46.00
3	0.24	3.00	25	1.98	25.00	47	3.73	47.00
4	0.32	4.00	26	2.06	26.00	48	3.81	48.00
5	0.40	5.00	27	2.14	27.00	49	3.89	49.00
6	0.48	6.00	28	2.22	28.00	50	3.98	50.00
7	0.56	7.00	29	2.30	29.00	51	4.05	51.00
8	0.63	8.00	30	2.38	30.00	52	4.13	52.00
9	0.71	9.00	31	2.46	31.00	53	4.21	53.00
10	0.79	10.00	32	2.54	32.00	54	4.29	54.00
11	0.87	11.00	33	2.62	33.00	55	4.37	55.00
12	0.95	12.00	34	2.70	34.00	56	4.44	56.00
13	1.03	13.00	35	2.78	35.00	57	4.52	57.00
14	1.11	14.00	36	2.86	36.00	58	4.60	58.00
15	1.19	15.00	37	2.94	37.00	59	4.68	59.00
16	1.27	16.00	38	3.02	38.00	60	4.76	60.00
17	1.35	17.00	39	3.10	39.00	61	4.84	61.00
18	1.43	18.00	40	3.17	40.00	62	4.92	62.00
19	1.51	19.00	41	3.25	41.00	63	5.00	63.00
20	1.59	20.00	42	3.33	42.00			
21	1.67	21.00	43	3.41	43.00			

11. Lockup Protection and Automatic Restart

If motor rotation is abnormal, and the motor stalls for a duration of T_{run} , the lock-up protection circuit will disable the driver (by setting its outputs to high-impedance) in order to prevent the motor coil from burnout. After a “waiting time (T_{wait})”, lock-up protection is released and normal operation will be resumed. Similarly, if rotation is abnormal for another time period, T_{run} , lock-up protection is triggered. T_{wait} and T_{run} timings are configurable with internal efuses and can be modified by user. The number of restarts after stall detection can also be configured to 1, 3, 8 or infinite times depending on efuse setting.

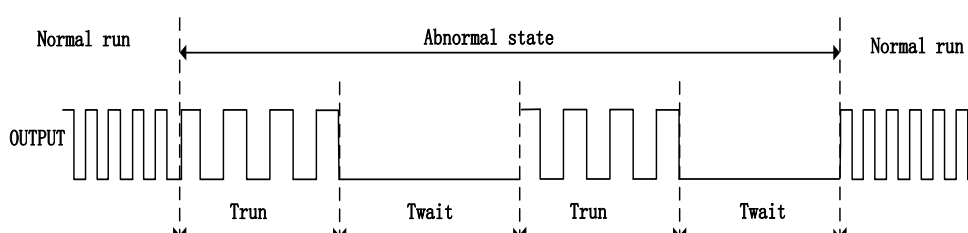

Figure 4 Lockup Protection and Automatic Restart

12. Current Protection

There are three methods of current protection: overload current limit protection, cycle by cycle current limit protection and over current protection. The overload current limit protection and cycle by cycle current limit protection of the motor can be selected by setting internal efuse

The current limit circuit limits the output current peak value to a level determined by the equation:

$$I = V_{ref1} / R_{ISENSE}$$

For the overload current protection mode, the current limit circuit detects the peak current of the output transistors at the ITRIP/ISENSE pin and then reduces the duty cycle of PWM.

For the cycle by cycle current protection mode, when the voltage at the ISENSE/ITRIP input is higher than Vref1, the current limit protection is generated and the output PWM is turned off and evaluated every PWM cycle.

For over current protection, when the voltage at the Itrip input is higher than vref2, the over current protection will be triggered, and outputs are immediately turned off. After a “waiting time” (Twait), the over current protection will be released and FT1128 restarts its operation with the startup sequence.

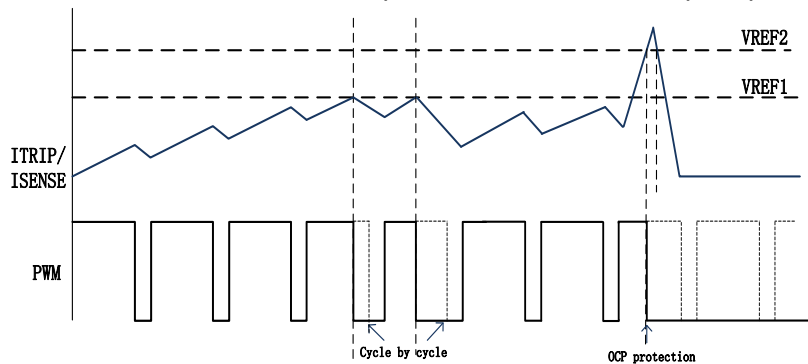

Figure5 Cycle by cycle current limit protection mode and over current protection

Vref1: Internal Reference voltage1, the vref1 voltage can be set to 0.15V、0.2V、0.25V or 0.3V by setting internal efuse.

Vref2: Internal Reference voltage2, typically 0.5V.

13. Thermal Protection.

FT1128 has a built in thermal shunt down function, which will shut down the device when the junction temperature is over 150°C and will resume operating when the junction temperature drops back to 120°C.

13. Brake Function (FT1128Q only)

FT1128Q comes with brake function. Braking comes intelligently for protective purpose. When BRAKE pin is set to low, if the motor is rotating above the brake threshold speed, output MOSFETs are turned off to brake the motor. However, if the motor is rotating below the brake threshold speed, and the lower legs of the output MOSFETs are turned on to brake the motor. The reason for this distinction is to protect the MOSFETs from excessive braking currents due to large back-EMF. User can set the safe back-EMF for short braking by setting brake threshold speed using the internal efuse.

14. Voltage protection (FT1128Q only)

FT1128Q provides a VDC_DETE input pin, which is used for FT1128Q have over voltage and under voltage protection. VDC_DETE can be connected to a stepped down VCC. When there is an overvoltage such that VDC_DETE exceeds 3.9V, FT1128Q will turn all MOS off. IC resumes to normal if VDC_DETE goes below 3.67V. Similarly, if there is an undervoltage such that VDC_DETE voltage goes below 1.2V, FT1128Q will turn all MOS off. IC resumes to normal if VDC_DETE exceeds 1.4V.

15. External Thermal Protection (FT1128Q only)

When thermal protection is triggered, that is when TDA is less than 2.12V, output PWM duty cycle will reduce till it reaches SMIN_DUTY. During this pwm duty reduction transition, the IC will respond only to input PWM duty level lower than its current level. Upon thermal recovery, that is when TDA is more than 2.25V, the output duty cycle will increase until it reaches to that of the input pwm duty. Normal operation will resume thereafter.

16. One time programmable.

FT1128 Efuse for chip configuration can only be programmed once. It is not reprogrammable.

Application Circuit Example

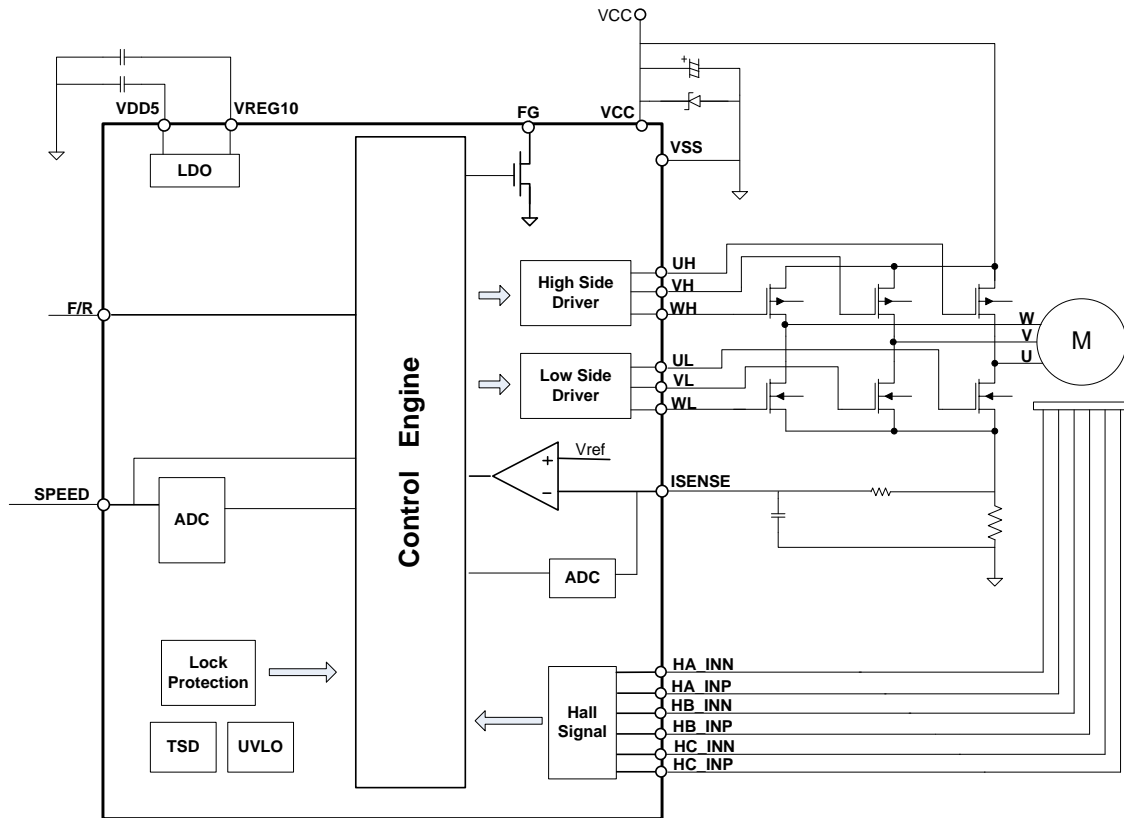

FT1128T Application Circuit

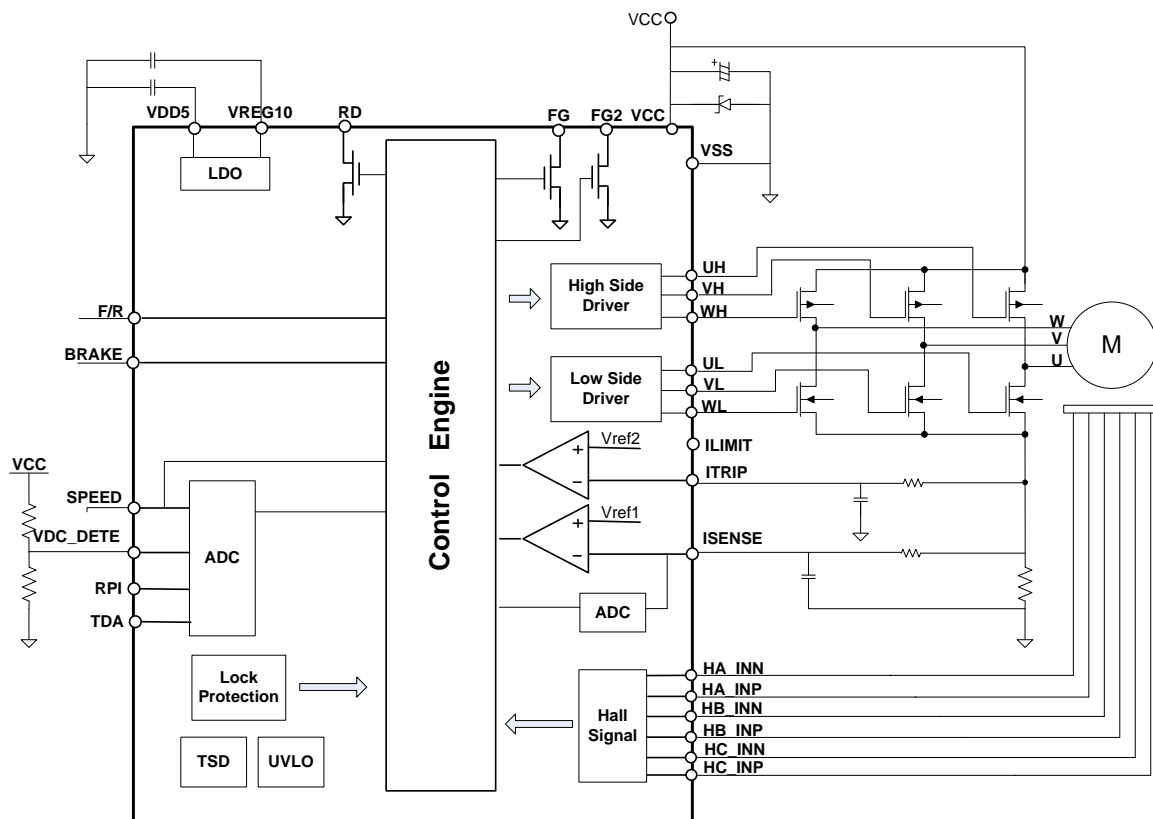

FT1128Q Application Circuit

Internal Equivalent Circuit of Pins

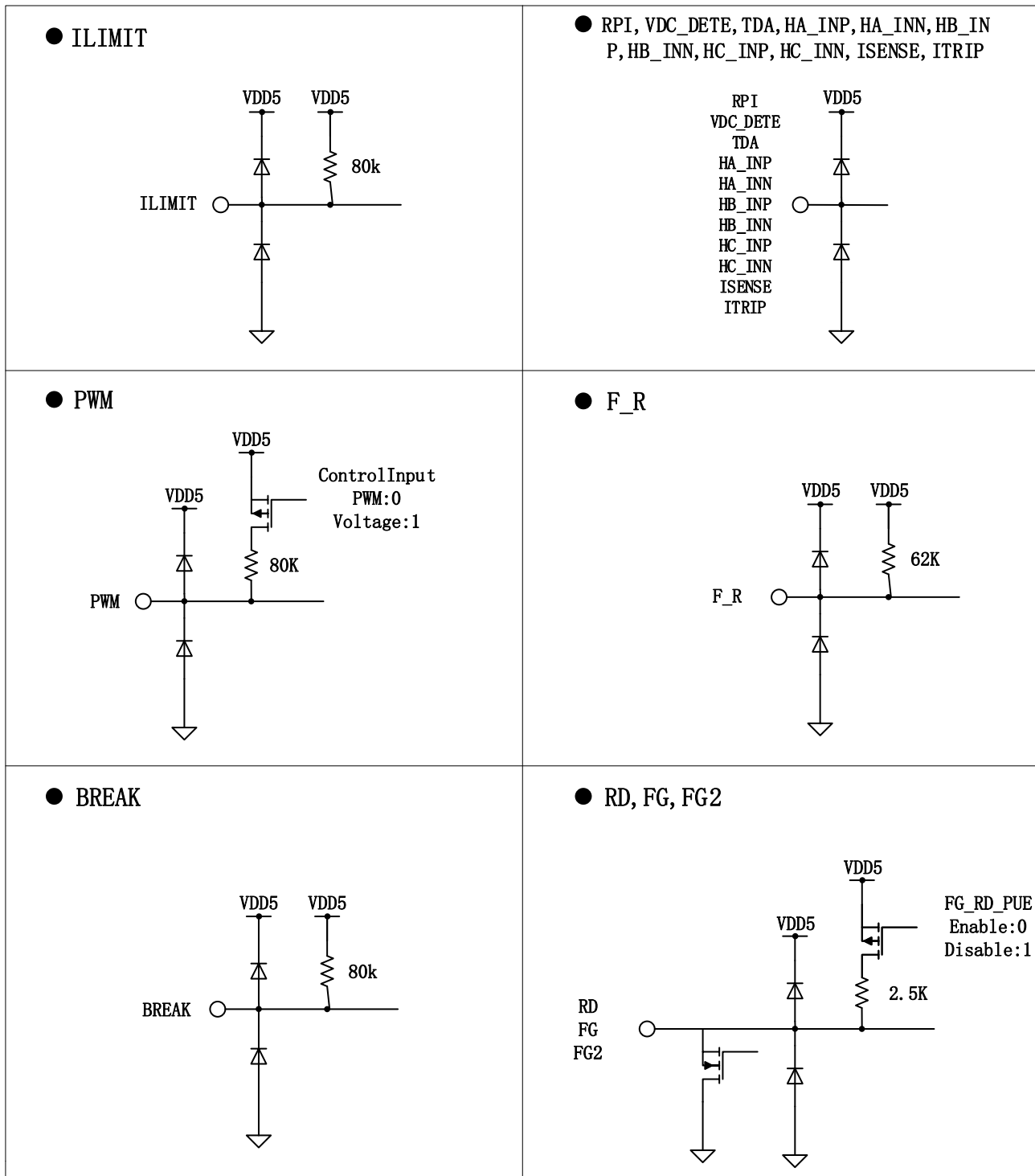

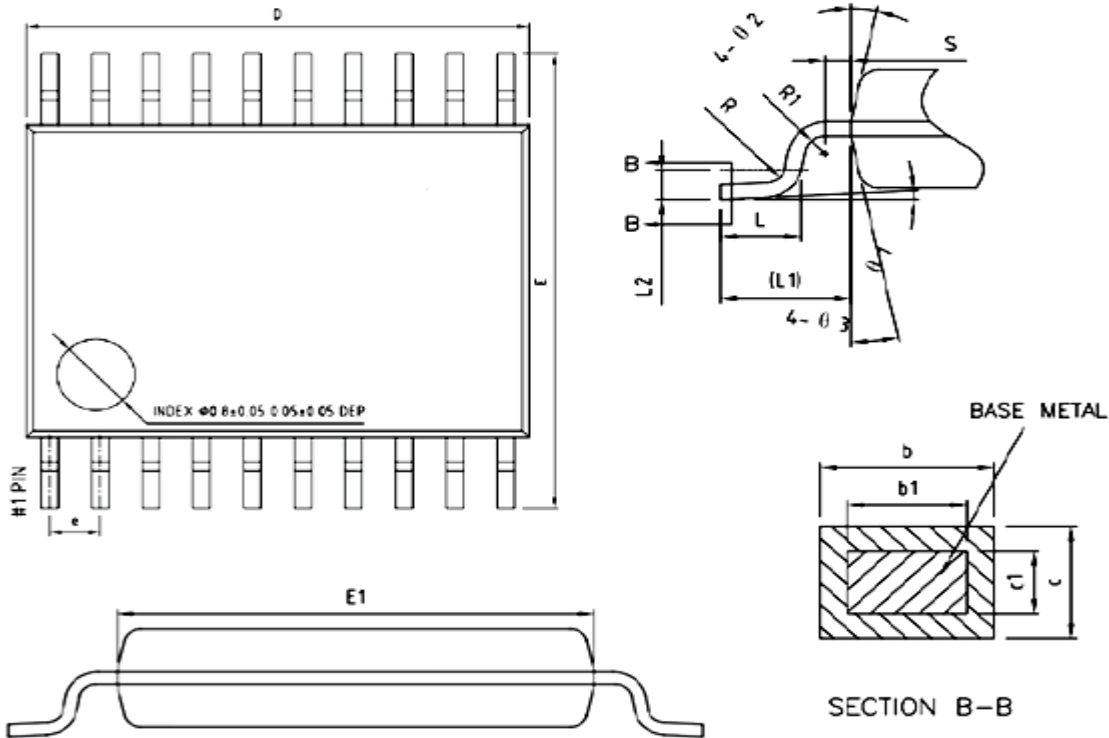
Package Information & Ordering Information
TSSOP-20

	MIN	NOM	MAX
A	-	-	1.20
A1	0.05	-	0.15
A2	0.80	1.00	1.05
b	0.19	-	0.30
b1	0.19	0.22	0.25
c	0.09	-	0.20
c1	0.09	-	0.16
D	6.40	6.50	6.60
E	6.20	6.40	6.60
E1	4.30	4.40	4.50
e	0.65BSC		
L	0.45	0.60	0.75
L1	1.00BSC		

Part Number	Package Type	Marking ID	Package Method	Quantity
FT1128T	TSSOP20	FT1128T	TUBE	46

QFN28 (5x5)

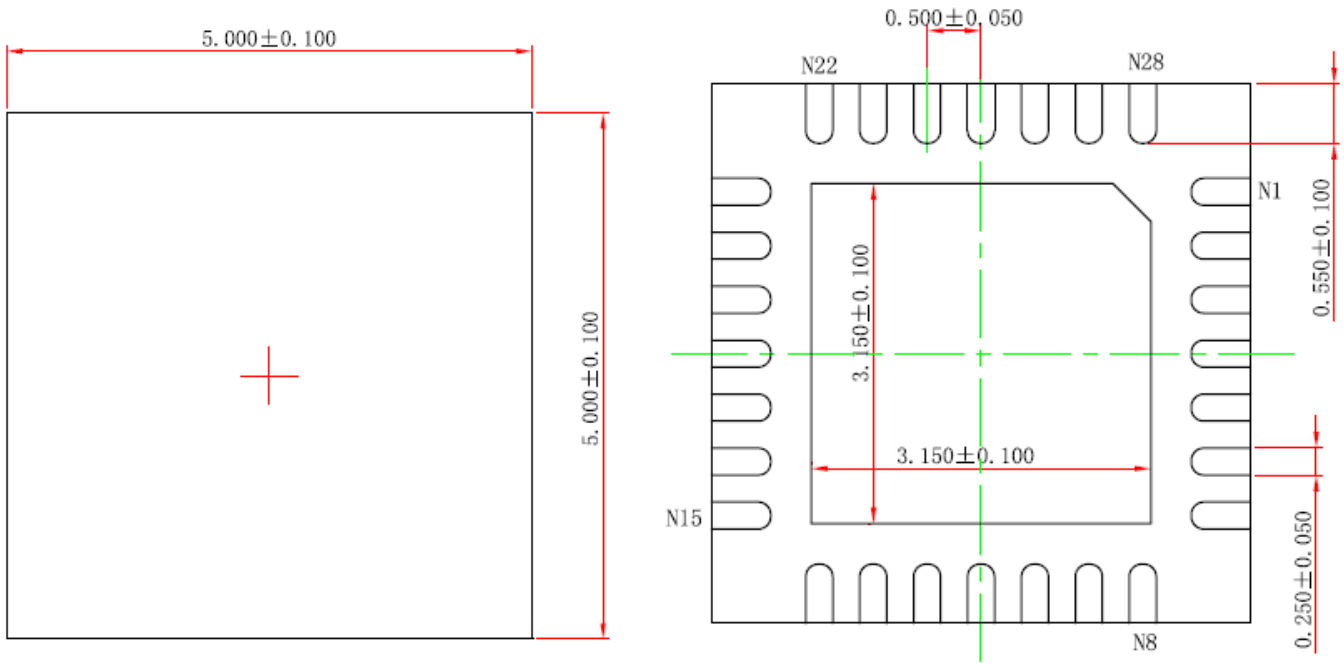

Top View

Bottom View

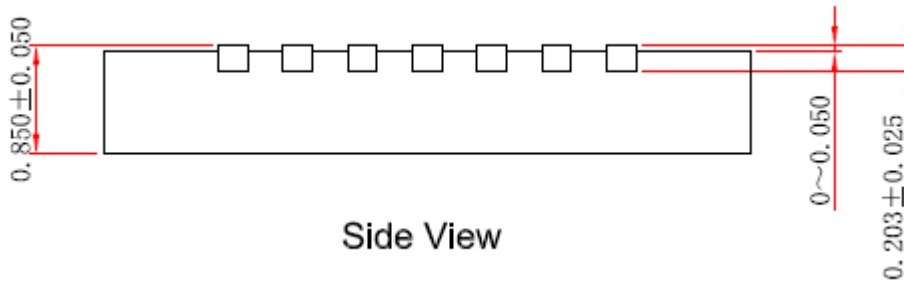

Side View

Part Number	Package Type	Marking ID	Package Method	Quantity
FT1128Q	QFN28(5*5)	FT1128Q	tray	490

Copyright Notice

Copyright by Fortior Technology (Shenzhen) Co., Ltd. All Rights Reserved.

Right to make changes —Fortior Technology (Shenzhen) Co., Ltd reserves the right to make changes in the products - including circuits, standard cells, and/or software - described or contained herein in order to improve design and/or performance. The information contained in this manual is provided for the general use by our customers. Our customers should be aware that the personal computer field is the subject of many patents. Our customers should ensure that they take appropriate action so that their use of our products does not infringe upon any patents. It is the policy of Fortior Technology (Shenzhen) Co., Ltd. to respect the valid patent rights of third parties and not to infringe upon or assist others to infringe upon such rights.

This manual is copyrighted by Fortior Technology (Shenzhen) Co., Ltd. You may not reproduce, transmit, transcribe, store in a retrieval system, or translate into any language, in any form or by any means, electronic, mechanical, magnetic, optical, chemical, manual, or otherwise, any part of this publication without the expressly written permission from Fortior Technology (Shenzhen) Co., Ltd.

Fortior Technology (Shenzhen) Co.,Ltd.

Room203, 2/F, Building No.11, Keji Central Road2,

Software Park, High-Tech Industrial Park, Shenzhen, P.R. China 518057

Tel: 0755-26867710

Fax: 0755-26867715

URL: <http://www.fortiortech.com>

Contained herein

Copyright by Fortior Technology (Shenzhen) Co.,Ltd all rights reserved.