

## Three Phase Sensorless BLDC Motor Driver

# FT3216

### Overview

The FT3216 is a Three Phase sensorless BLDC motor driver. Due to its adaptive features and wide power-supply range capabilities, it is intended to cover a wide range of motor characteristics, while requiring minimal tuning from the user. Speed adjustment can be achieved through either direct-PWM or analog voltage control. Speed indicator is provided through a Frequency Generator output, generating digital pulse with its frequency proportional to the speed of the motor.

Protection functions of FT3216 are comprehensive including lock protection and automatic recovery, under voltage, thermal shutdown, current limit and over current protections. These prevent the control circuits and the motor from being damaged, particularly under stressed applications and

demanding environments.

### Features

- Position sensorless BLDC controller
- Selectable soft switch SBLDC (150°) or BLDC (120°) drives
- PWM speed input
- Analog speed input
- Soft start
- FG (Frequency Generator) and RD (Rotation detection) output
- Current limit and internal over current protection
- Lock protection
- Built-in thermal shutdown protection (TSD)
- Built-in Under Voltage Lock Out (UVLO)
- Low Rds (1.0Ω)

### Block Diagram

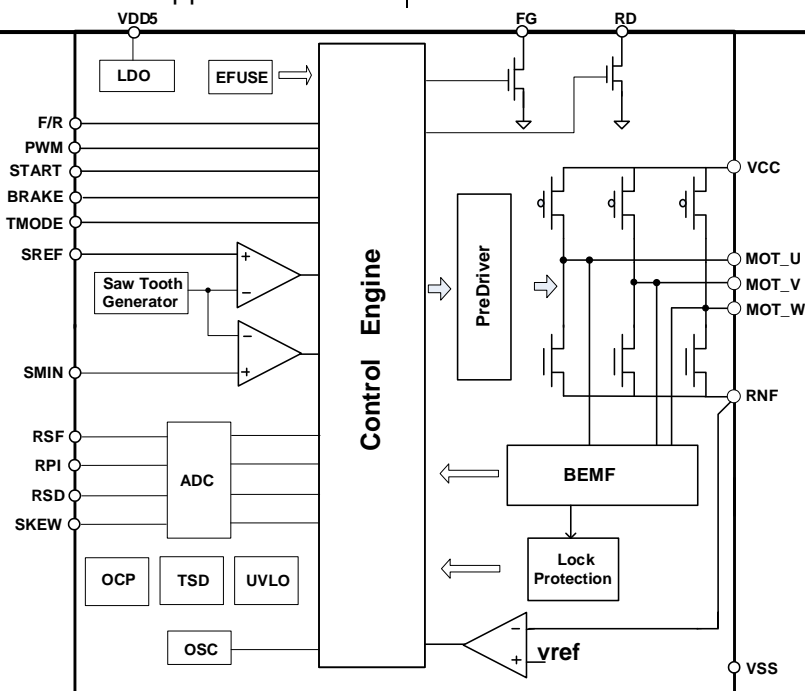

## 1. Pin Assignment

Package: TSSOP20

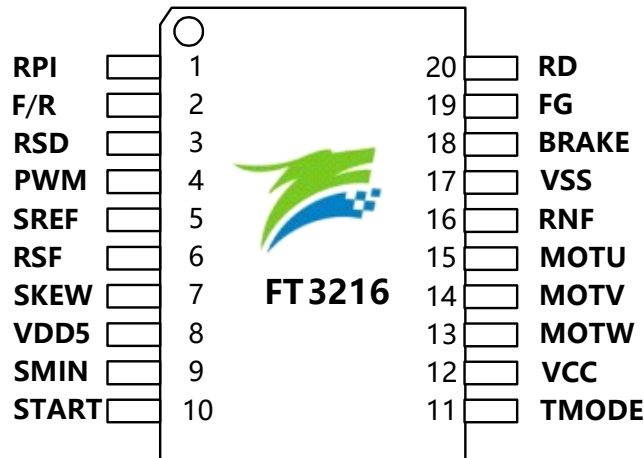

**Table 1 Pin Configuration**

PIN NO.	PIN Name	Type	Description
1	RPI	I	Initial PWM duty cycle setting.
2	F/R	I	Motor rotation direction input
3	RSD	I	Stall protection time setting
4	PWM	I	PWM input for speed adjustment. Internal pull-up
5	SREF	I	Analog input voltage for speed adjustment.
6	RSF	I	Start frequency setting
7	SKEW	I	Soft start time setting
8	VDD5	O	Digital power output, LDO DC5V output for digital signal.
9	SMIN	I	Minimum speed setting
10	START	I	Motor start input. High: Start; Low: Free. Internal pull-up
11	TMODE	I	Test signal input, connect to GND
12	VCC	P	Power supply
13	MOT_W	O	Motor output W
14	MOT_V	O	Motor output V
15	MOT_U	O	Motor output U
16	RNF	O	Output current detection pin
17	VSS	G	Signal and power ground.
18	BRAKE	I	Brake signal input, Low: Brake. Internal pull-up.
19	FG	O	Open drain. Frequency Generator, speed signal output.
20	RD	O	Open drain. Motor rotate detection output.

## 2. Absolute Maximum Ratings (@Ta=25°C)

Stresses exceeding the absolute maximum ratings may damage the device. The device may be damaged or may not function or be operational above these ratings and stressing the device to/above these levels is not recommended. Fortior does not recommend exceeding or designing about the Absolute Maximum Ratings.

**Table 2**

Parameter	Symbol	Condition	Ratings	Unit
Power supply voltage	VCC max		30	V
Output current	I <sub>OUT</sub> max	Peak (startup and lock rotor)	1.5	A
		Duty cycle = 100%, VCC=12V	800	mA
		Duty cycle = 100%, VCC=24V	700	mA
Logic input pin withstand voltage	V <sub>logic</sub> max		5.5	V
RD/FG output pin withstand voltage	V <sub>FG</sub> max		5.5	V
RD/FG output current	I <sub>FG</sub> max		10	mA
Operating temperature	T <sub>opr</sub>		-40 ~ +85	°C
Storage temperature	T <sub>stg</sub>		-65 ~ +150	°C

## 3. Recommended Operating Conditions

**Table 3**

Parameter	Symbol	Condition	Ratings	Unit
Power supply voltage	VCC		4.5~28	V

## 4. Electrical Characteristics

**Table 4** (Unless otherwise specified, Ta = 25°C, VCC = 24 V)

Parameter	Symbol	Condition	Ratings			Unit
			Min.	Typ.	Max.	
Power supply current 1	I <sub>cc1</sub>	Working current	-	15		mA
Power supply current 2	I <sub>cc2</sub>	Standby current	-	1.5		mA
<b>Output Block</b>						
High-side switch ON resistance	R <sub>on</sub> (H)	I <sub>o</sub> = 0.5A	-	0.55	0.9	Ω
Low-side switch ON resistance	R <sub>on</sub> (L)	I <sub>o</sub> = 0.5A	-	0.45	0.7	Ω
<b>5V Regulator Block</b>						
Regulator voltage	V <sub>dd5</sub>	I <sub>o</sub> = 10mA	4.75	5	5.25	V
Regulator output current	I <sub>v5out</sub>	V <sub>reg5</sub> =5V			10	mA
<b>Analog I/O Section *Note1</b>						
Analog Input range			0		5	V
<b>Digital I/O Section *Note2</b>						
Digital high-level input voltage	V <sub>dinh</sub>	-	2.3	-	5.3	V
Digital low-level input voltage	V <sub>dinl</sub>	-	0	-	1.0	V
Digital I/O internal pull up resistor	R <sub>dio</sub>	-	150k	200k	250k	ohm

Parameter	Symbol	Condition	Ratings			Unit
			Min.	Typ.	Max.	
<b>Internal PWM Block</b>						
Saw tooth Frequency	VPWM		22.5	25	27.5	KHz
VPWM High Level Voltage	VPWMH		3.56	3.75	3.94	V
VPWM Low Level Voltage	VPWML		0.71	0.75	0.79	V
<b>FG/RD Output Pin</b>						
FG/RD output pin low-level voltage	VFG	When $I_o = 5 \text{ mA}$	-	0.1	0.2	V
<b>Thermal Protection Circuit</b>						
Thermal protection circuit operating temperature	TSD	Design target	-	165	-	°C
Temperature hysteresis width	$\Delta TSD$	Design target	-	30	-	°C
<b>Low-Voltage Detection</b>						
Low voltage detection voltage	UVLO			3.3		V
<b>ADC</b>						
Input range	Vin		0	-	VDD5	V
Resolution	N			6		BIT

**Notes:**

**\*Note1:** RSF、RPI、SKEW、RSD、SREF、SMIN

**\*Note2:** F/R、START、PWM、BRAKE

## Functional Description and Notes

Please read the following notes before designing driver circuits with FT3216.

### 1. Motor Start.

This is followed with a forced commutation mode, where the duty cycle of PWM and the frequency of commutation are determined by the RPI pin and the RSF pin separately. The duty cycle of PWM increases proportionally with the increasing RPI voltage, while the period of commutation increases proportionally with the RSF voltage. The RSF and RPI voltage settings may vary depending on the motor type and load, so that they should be experimentally adjusted carefully. Starting of motor may fail if unsuitable values of RSF and RPI are used. The voltage range of RPI and RSF is 0V to VDD5. When the motor rotates, generating stable and detectable back-EMF, correct position can be detected and forced commutation will transit into sensorless commutation.

Soft start function is controlled by SKEW voltage. This is achieved by limiting the internal speed response slew rate to slow the rate of change of PWM duty cycle delivered to the motor phases. The SKEW voltage is higher, the startup time is longer.

### 2. PWM Output

FT3216 can be programmed to drive the motor with the traditional BLDC (120°) mode. The voltage and current sequence diagram is shown in Figure 1.

FT3216 can select synchronous rectification in the BLCD mode by programming efuse , and is intended to reduce heat generation compared to diode regeneration.

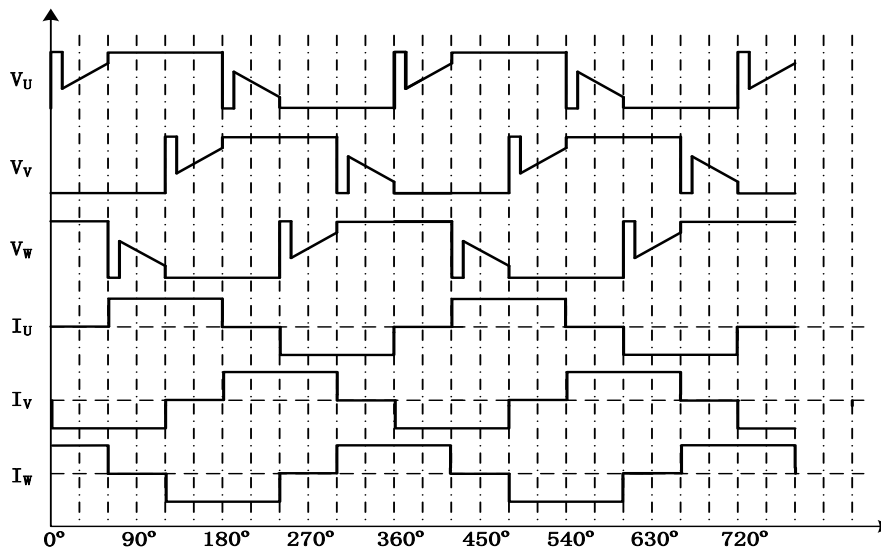

Figure 1 Voltage and Current Sequence diagram

FT3216 can also be programmed to drive the motor with the traditional SBLDC (150°) mode. Under SBLDC mode, the phase currents are quasi-sinusoidal for acoustic noise reduction. The voltage and current sequence diagram is shown in Figure 2.

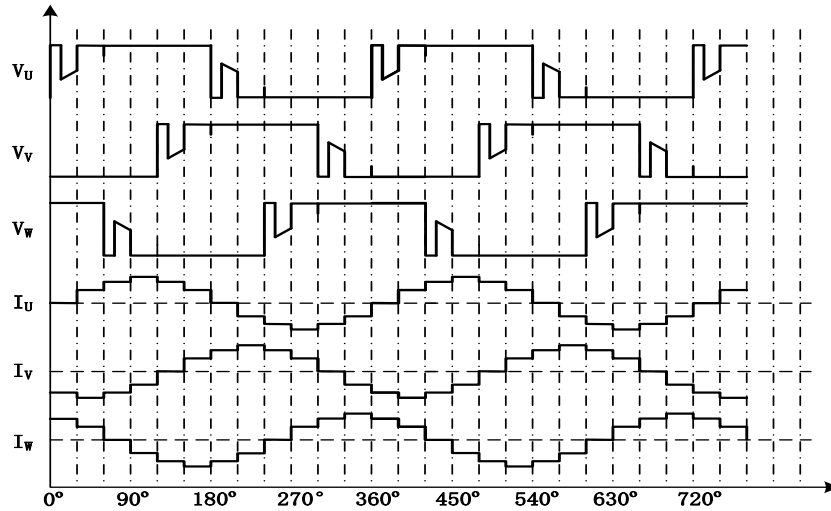

Figure 2 Voltage and Current Sequence diagram

### 3. Speed Control Methods

FT3216 has two methods to adjust the motor speed, using PWM pin by adjusting its duty cycle or using SREF pin by adjusting the voltage level. Please note that during speed adjustment with PWM, SREF must be disabled and pulled high. Conversely during speed adjustment with SREF, PWM must be disabled and pulled high.

When adjusting speed with PWM, the speed is varied by performing switching in accordance with the duty cycle that is provided to the PWM pin. When adjusting speed with SREF, speed is adjusted by an internally generated PWM with the duty cycle determined by the equation:

$$Duty\_cycle = \frac{V_{SREF} - 0.75}{3}$$

When the SREF pin is connected to VDD5 and the motor speed will rise to full speed. When SREF pin is lower than 0.75V during operation, the motor will slow down and stop.

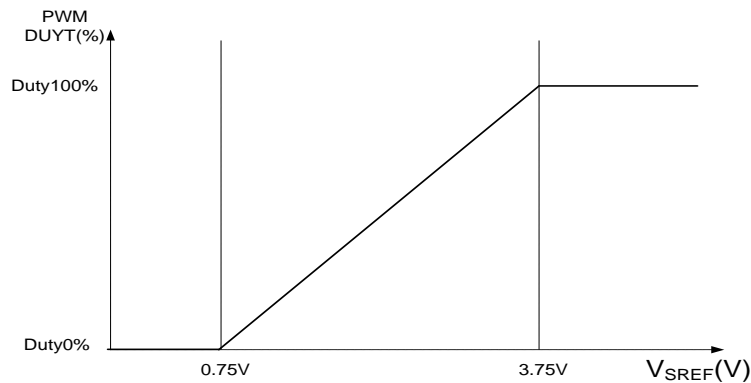

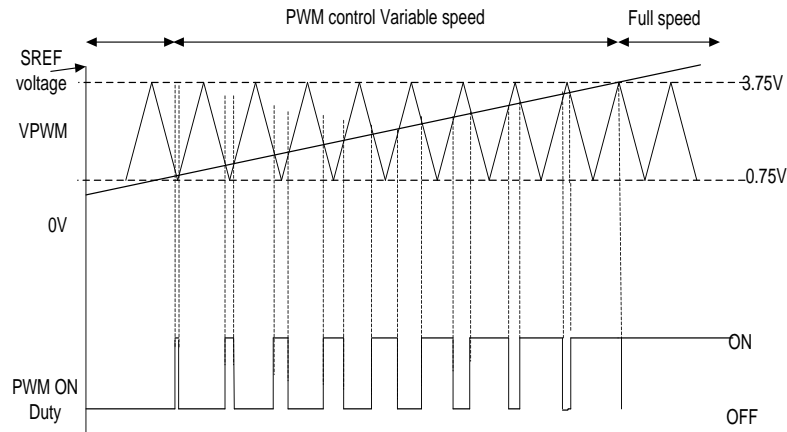

Figure 3 Rotation Speed Control Chart

When the rotate speed is very low, the motor possible appear discontinuous state of rotation. Minimum speed setting is controlled by SMIN pin to prevent this condition. When the voltage of SREF pin is less than the voltage of SMIN pin, PWM is immediately turned off. SMIN pin can be pulled low or set by programming efuse if minimum speed limit is not needed.

#### 4. Frequency Generator Function

The Frequency Generator output generates a rotation pulse to give information about the speed of motor. The default setting is 1 pulse per electrical degree (FG). The FG pin is an open drain output, connecting to a logical voltage level through an external pull-up resistor. This pin can be left open if unused.

#### 5. Setting of Function

Many functions can be set by programming efuse within the chip. These functions include: selection of SBLDC (quasi-sinusoidal) or BLDC (120°) modulation mode, selection of Synchronous rectification (Synchronous rectification and normal mode ), etc.

#### 6. Brake Function

FT3216 comes with brake function. Braking comes intelligently for protective purpose. When BRAKE pin is set to low, if the motor is rotating above the brake threshold speed, output MOSFETs are turned off to brake the motor. However, if the motor is rotating below the brake threshold speed, and the lower legs of the output MOSFETs are turned on to brake the motor. The reason for this distinction is to protect the MOSFETs from excessive braking currents due to large back-EMF. User can set the safe back-EMF for short braking by setting brake threshold speed using the internal efuse.

#### 7. Forward and Reverse

FT3216 has an FR pin to set the motor for a forward spin or reverse spin. The spin direction of the motor can be changed when during normal operation or can be set before power up. During normal operation, when FR status is changed, the motor break first and after a waiting time (FR\_DELAY), the motor is reverse. FR\_DELAY is configurable with internal efuse and can be modified by user.

## 8. Lockup Protection and Automatic Restart

If motor rotation is abnormal, the internal detection circuit starts self-locking detection for a given time (Trun). If the motor keeps stalling under the Trun, the lock-up protection circuit disable the driver (by setting its outputs to high-impedance) in order to prevent the motor coil from burnout and the RD pin goes logic high. After a “waiting time (Twait)”, the lock-up protection is released and normal operation resumes. Similarly if rotation is abnormal for another time period, Trun, lock-up protection is triggered. Trun timing is configurable with internal efuse and can be modified by user. Twait timing is configurable with RSD pin. If automatic restart is not needed, it can be canceled with internal effuse and the motor remains stop after the first Trun.

The RD pin is an open drain output. During the lock-up protection condition, RD output will keep high until the lock-up protection is dismissed and restart completed. This pin can be left open if unused.

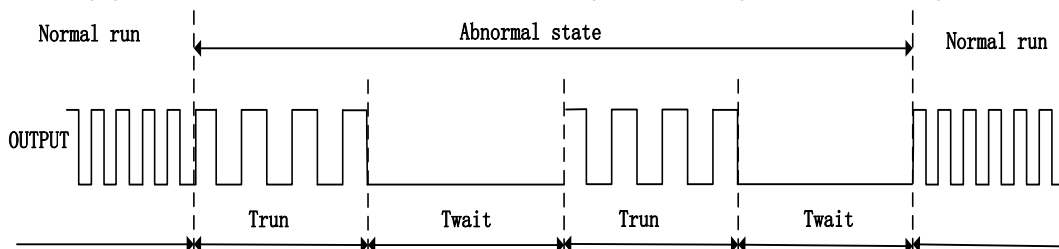

Figure4 Lock-up Protection and Automatic Restart

## 9. Current Protections.

There are three methods of current protection: overload current protection, cycle by cycle current protection and build-in over current protection. The overload current protection and cycle by cycle current protection of the motor can be selected by setting internal efuse.

The current limit circuit limits the output current peak value to a level determined by the equation:

$$I = V_{RNF} / R_{RNF}$$

$V_{RNF}$  is configurable with internal efuse and it has four level can be set by users.  $R_{RNF}$  is current detection resistor.

For the overload current protection mode, the current limit circuit detects the voltage at the RNF input is higher than  $V_{RNF}$  and then reduces the duty cycle of PWM.

For the cycle by cycle current protection mode, when the voltage at the RNF input is higher than  $V_{RNF}$ , the current limit protection is generated and the output PWM is turned off and evaluated every PWM cycle.

For over current detection, if current is higher than 1.5A, the over current protection is triggered, PWM is immediately turned off. After a “waiting time” (Twait), the over current protection is released and FT3216 restarts its operation with the startup sequence. If automatic restart is not needed, it can be canceled with internal efuse and the motor remains stop after the over current protection is triggered.



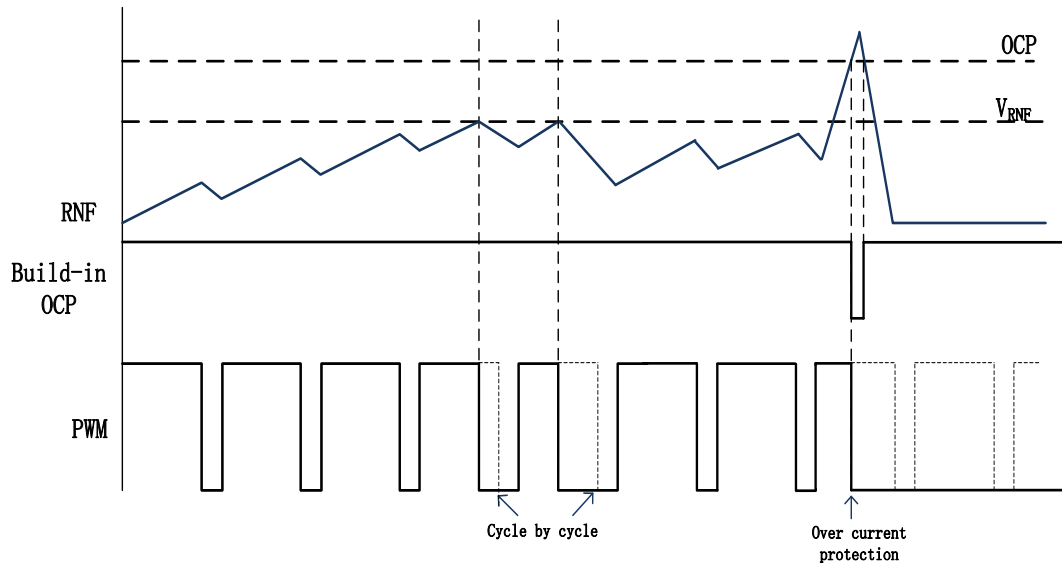

Figure 5 Cycle by cycle current protection mode

## 10. UVLO.

FT3216 has a built-in UVLO function block. The device will be locked out when VCC reaches 3.3 V and woke up at 3.3 V.

## 11. Thermal Protection.

FT3216 has a built in thermal shunt down function, which will shut down the device when the junction temperature is over 165°C and will resume operating when the junction temperature drops back to 135°C.

### 5. Application Circuit Example

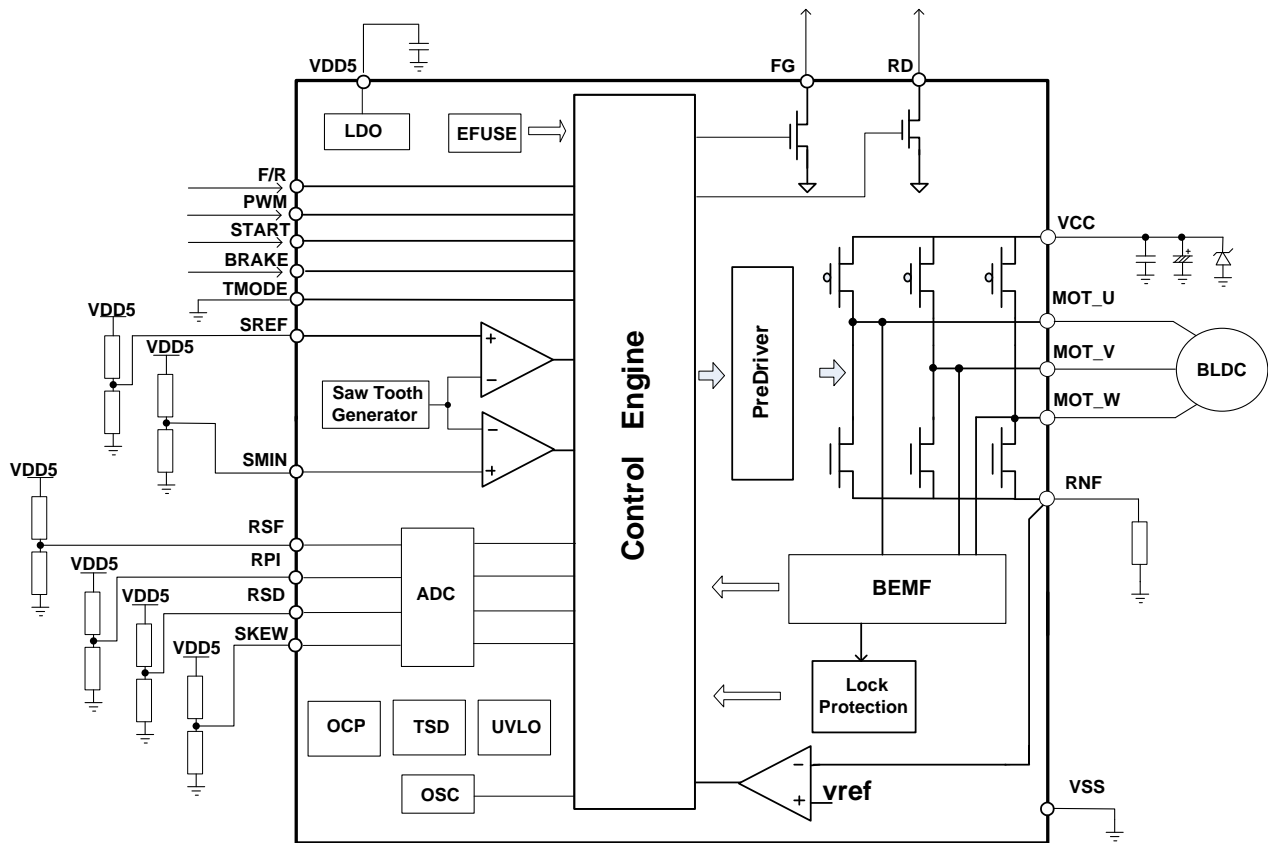

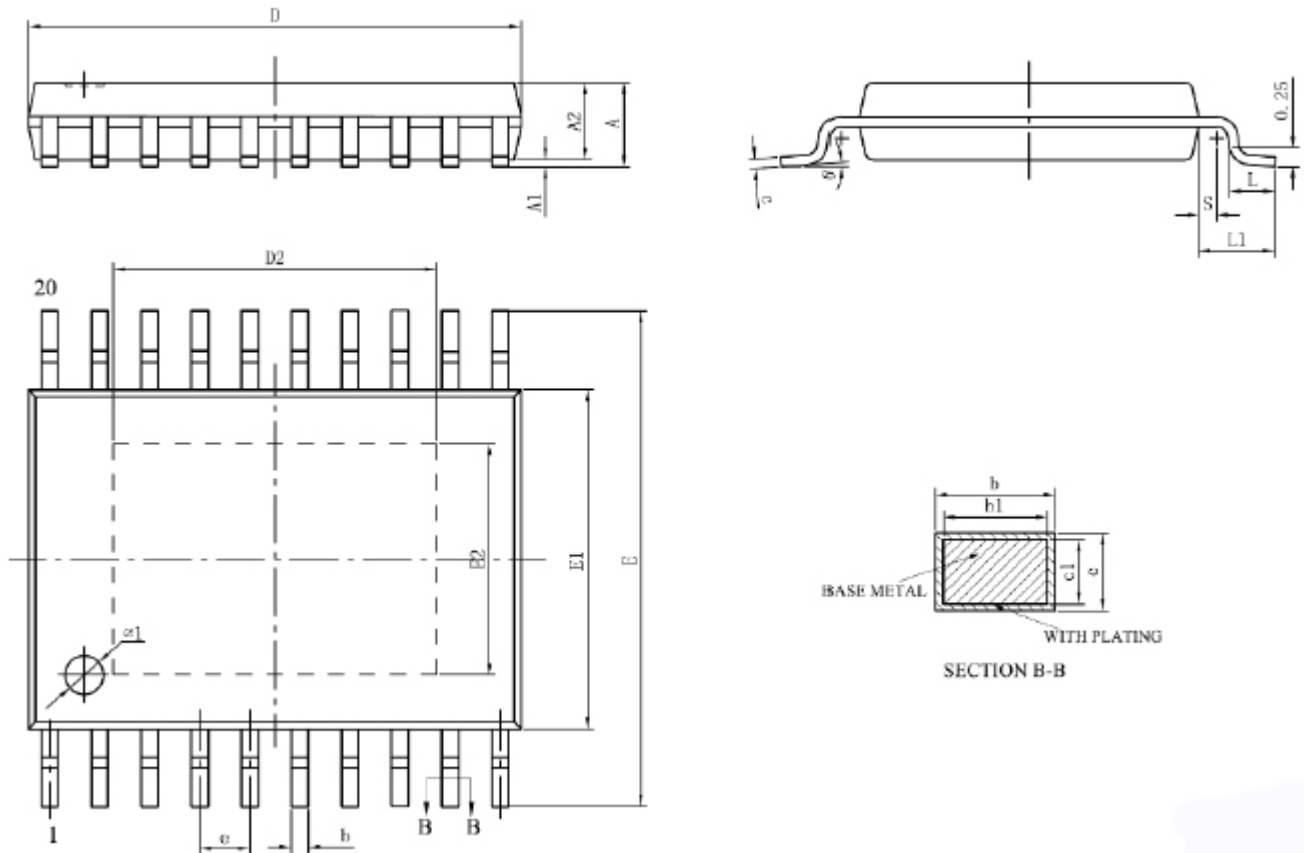
**6. Package Information (TSSOP20)**

SYMBOL	MILLIMETER		
	MIN	NOM	MAX
A	—	—	1.20
A1	0.05	—	0.15
A2	0.80	1.00	1.05
b	0.19	—	0.30
b1	0.19	0.22	0.25
c	0.09	—	0.20
c1	0.09	—	0.16
D	6.40	6.50	6.60
D2	4.10	4.20	4.30
E2	2.90	3.00	3.10
E1	4.30	4.40	4.50
E	6.20	6.40	6.60
e	0.65BSC		
L	0.45	0.60	0.75
L1	1.00BSC		
S	0.20	—	—
Ø1	Ø0.8×0.05~0.10DP		
θ	0	—	8°
L/F 载体尺寸(mil)	118*165 (C)		

## Copyright Notice

Copyright by Fortior Technology (Shenzhen) Co., Ltd. All Rights Reserved.

Right to make changes —Fortior Technology (Shenzhen) Co., Ltd reserves the right to make changes in the products - including circuits, standard cells, and/or software - described or contained herein in order to improve design and/or performance. The information contained in this manual is provided for the general use by our customers. Our customers should be aware that the personal computer field is the subject of many patents. Our customers should ensure that they take appropriate action so that their use of our products does not infringe upon any patents. It is the policy of Fortior Technology (Shenzhen) Co., Ltd. to respect the valid patent rights of third parties and not to infringe upon or assist others to infringe upon such rights.

This manual is copyrighted by Fortior Technology (Shenzhen) Co., Ltd. You may not reproduce, transmit, transcribe, store in a retrieval system, or translate into any language, in any form or by any means, electronic, mechanical, magnetic, optical, chemical, manual, or otherwise, any part of this publication without the expressly written permission from Fortior Technology (Shenzhen) Co., Ltd.

## Fortior Technology (Shenzhen) Co., Ltd.

Room203, 2/F, Building No.11, Keji Central Road2,  
Software Park, High-Tech Industrial Park, Shenzhen, P.R. China 518057  
Tel: 0755-26867710  
Fax: 0755-26867715  
URL: <http://www.fortiortech.com>

## Contained herein

**Copyright by Fortior Technology (Shenzhen) Co., Ltd all rights reserved.**