

SPTECH Product Specification

SPTECH Silicon NPN Darlington Power Transistor

TIP121

DESCRIPTION

- High DC Current Gain-
: $h_{FE} = 1000(\text{Min})@ I_C = 3A$
- Collector-Emitter Sustaining Voltage-
: $V_{CEO(\text{SUS})} = 80V(\text{Min})$
- Low Collector-Emitter Saturation Voltage-
: $V_{CE(\text{sat})} = 2.0V(\text{Max})@ I_C = 3A$
= $4.0V(\text{Max})@ I_C = 5A$
- Complement to Type TIP126

APPLICATIONS

- Designed for general purpose amplifier and low speed switching applications.

ABSOLUTE MAXIMUM RATINGS ($T_a = 25^\circ\text{C}$)

SYMBOL	PARAMETER	VALUE	UNIT
V_{CBO}	Collector-Base Voltage	80	V
V_{CEO}	Collector-Emitter Voltage	80	V
V_{EBO}	Emitter-Base Voltage	5	V
I_C	Collector Current-Continuous	5	A
I_{CM}	Collector Current-Peak	8	A
I_B	Base Current	120	mA
P_C	Collector Power Dissipation $T_c = 25^\circ\text{C}$	65	W
	Collector Power Dissipation $T_a = 25^\circ\text{C}$	2	
T_j	Junction Temperature	150	$^\circ\text{C}$
T_{stg}	Storage Temperature Range	-65~150	$^\circ\text{C}$

THERMAL CHARACTERISTICS

SYMBOL	PARAMETER	MAX	UNIT
$R_{th\ j-c}$	Thermal Resistance, Junction to Case	1.92	$^\circ\text{C}/\text{W}$
$R_{th\ j-a}$	Thermal Resistance, Junction to Ambient	62.5	$^\circ\text{C}/\text{W}$

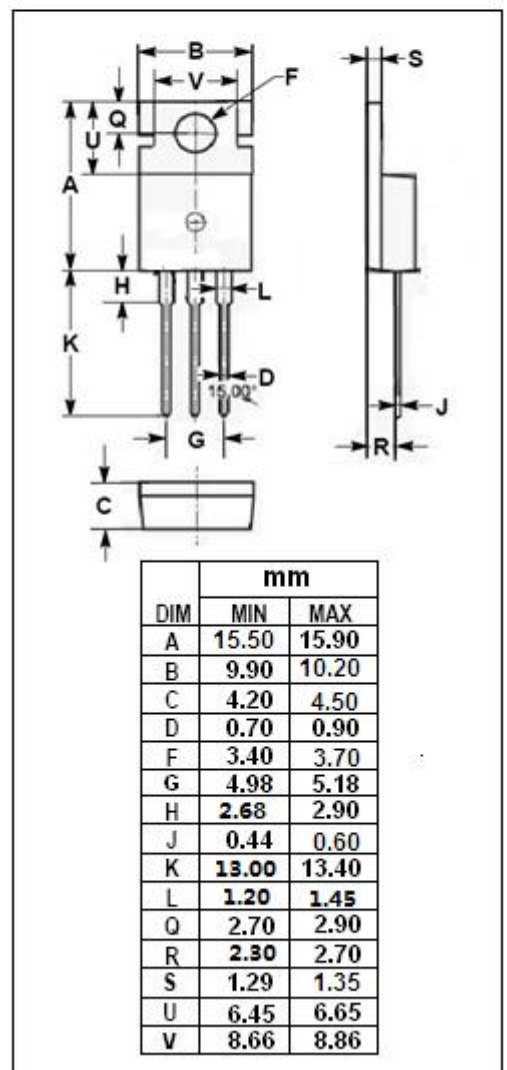
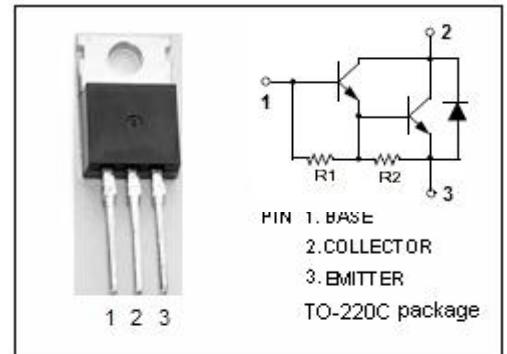

**SPTECH Silicon NPN Darlington Power Transistor
TIP121**

ELECTRICAL CHARACTERISTICS

T_c=25°C unless otherwise specified

SYMBOL	PARAMETER	CONDITIONS	MIN	TYP.	MAX	UNIT
V _{CEO(SUS)}	Collector-Emitter Sustaining Voltage	I _C = 30mA, I _B = 0	80			V
V _{CE(sat)-1}	Collector-Emitter Saturation Voltage	I _C = 3A ,I _B = 12mA			2.0	V
V _{CE(sat)-2}	Collector-Emitter Saturation voltage	I _C = 5A ,I _B = 20mA			4.0	V
V _{BE(on)}	Base-Emitter On Voltage	I _C = 3.0A ; V _{CE} = 3V			2.5	V
I _{CBO}	Collector Cutoff Current	V _{CB} = 80V, I _E = 0			0.2	mA
I _{CEO}	Collector Cutoff Current	V _{CE} = 40V, I _B = 0			0.5	mA
I _{EBO}	Emitter Cutoff Current	V _{EB} = 5V; I _C = 0			2	mA
h _{FE-1}	DC Current Gain	I _C = 0.5A; V _{CE} = 3V	1000			
h _{FE-2}	DC Current Gain	I _C = 3.0A; V _{CE} = 3V	1000			
C _{OB}	Output Capacitance	I _E = 0; V _{CB} = 10V, f= 0.1MHz			200	pF