

| | | | | |
|-----------|--------------|-------|--------------|-------|
| MFG. ENG. | APPROVED BY: | DATE: | APPROVED BY: | DATE: |
| | | | QA | |

NOTES:

1. ALL PARTS ARE BULK PACKED.
2. REFER TO DRAWING HPMCSTD FOR CONTACT PATTERNS.
3. ALL DIMENSIONS ARE REFERENCE ONLY IN INCHES [mm], WITHIN ±0.015 UNLESS OTHERWISE NOTED.

| ASS'Y P/N | CONTACT QTY. | CABLE O.D. RANGE |
|------------------|--------------|-------------------------|
| W18882-4PG-P-518 | 4 | 0.18 - 0.20 [4.6 - 5.1] |
| W18882-4PG-P-521 | 4 | 0.21 - 0.22 [5.3 - 5.6] |
| W18882-4PG-P-522 | 4 | 0.22 - 0.23 [5.6 - 5.8] |
| W18882-4PG-P-5XX | 4 | |

GROMMET SIZE = CABLE O.D. RANGE:
 518 = 0.18 - 0.20 [4.6 - 5.1]
 521 = 0.21 - 0.22 [5.3 - 5.6]
 522 = 0.22 - 0.23 [5.6 - 5.8]

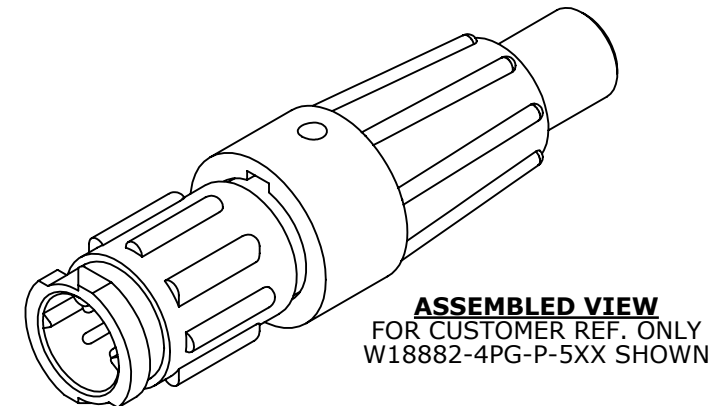
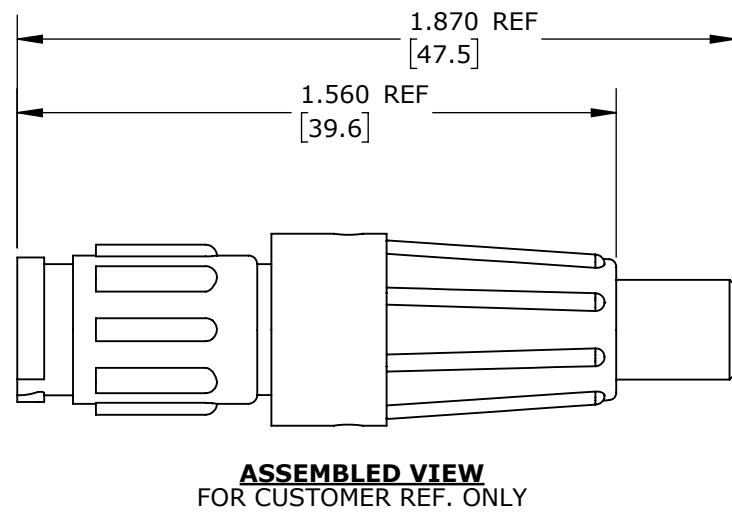
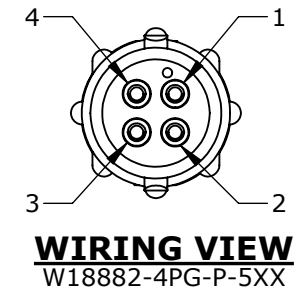
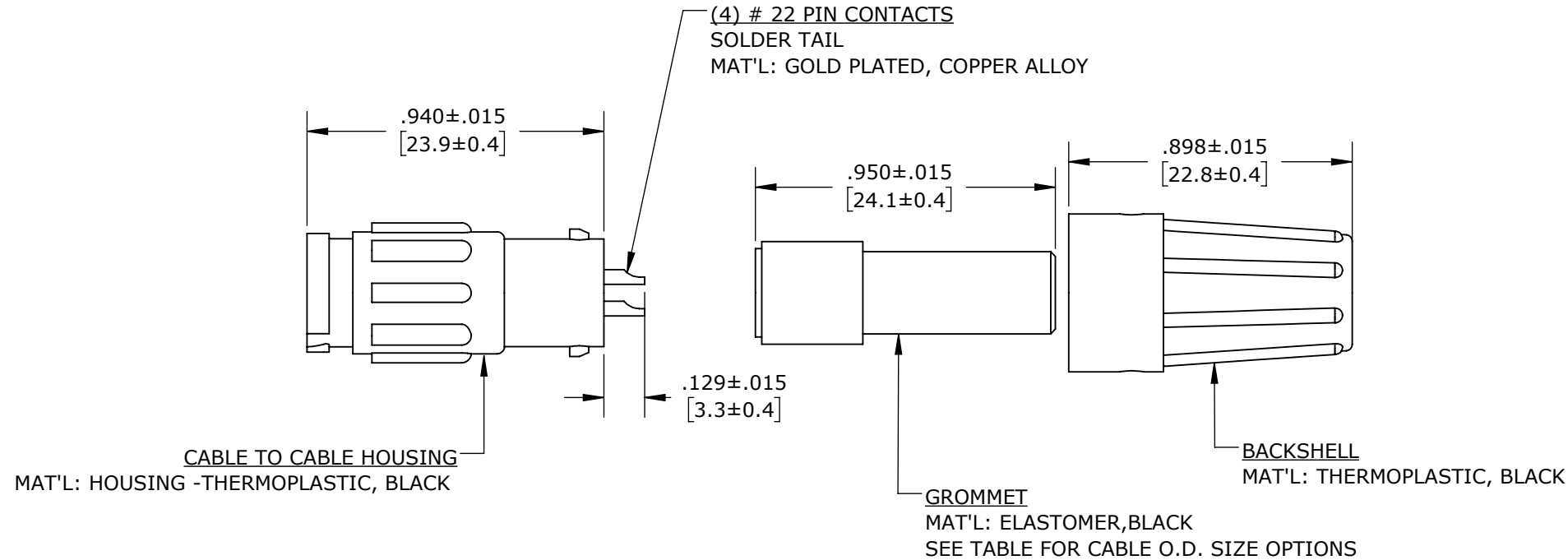
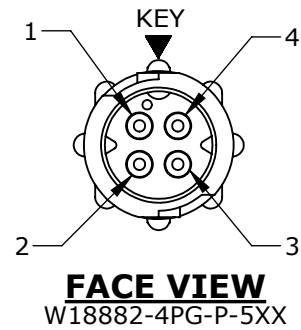

CUSTOMER APPROVAL

THIS DOCUMENT CONTAINS CONFIDENTIAL INFORMATION PROPRIETARY TO CONXALL CORPORATION. ANY REPRODUCTION, DISCLOSURE, OR USE OF THIS DOCUMENT /INFORMATION IS EXPRESSLY PROHIBITED UNLESS AUTHORIZED IN WRITING BY CONXALL CORPORATION.

APPROVED BY: _____

DATE: _____

RoHS COMPLIANT

DIMENSIONS IS BRACKETS [] ARE METRIC

PRELIMINARY

| | | | | |
|------------------|------------|------------------|--|--|
| 0A | JGK | 8/27/19 | DRAWING CREATED FOR PDR #18004. | |
| REV. | INIT. | DATE | DESCRIPTION | |
| | JGK | 8/27/19 | ALL INFORMATION ILLUSTRATED IS THE PROPERTY OF CONXALL CORPORATION. UNAUTHORIZED DUPLICATION OR DISTRIBUTION OF THIS DOCUMENT IS PROHIBITED. | |
| APPROVED BY: | | | 601 E. WILDWOOD VILLA PARK, IL 60181 | |
| TITLE: | | | CABLE TO CABLE CONN. ASS'Y (4) #22 PIN CONTACTS, SOLDER TAIL | |
| CUSTOMER: | | | INSTA-CLICK, MICRO-CON-X STANDARD PRODUCT | |
| SCALE | SIZE | SHEET | PART NUMBER: W18882-4PG-P-5XX | |
| NTS | B | 1 OF 1 | REV 0A | |
| FILE: | DIRECTORY: | PART NUMBER: | | |
| W18882-4PG-P-5XX | SLW | W18882-4PG-P-5XX | | |

CUSTOMER PRINT

PART NUMBER: W18882-4PG-P-5XX