

SPTECH Silicon NPN Power Transistor

BU2720DX

DESCRIPTION

- High Switching Speed
- High Voltage
- Built-in Ddamper Ddiode

APPLICATIONS

- Designed for use in horizontal deflection circuits of color TV receivers.

ABSOLUTE MAXIMUM RATINGS(T_a=25°C)

SYMBOL	PARAMETER	VALUE	UNIT
V _{CES}	Collector- Emitter Voltage(V _{BE} = 0)	1600	V
V _{CEO}	Collector-Emitter Voltage	825	V
V _{EBO}	Emitter-Base Voltage	7.5	V
I _C	Collector Current- Continuous	10	A
I _{CM}	Collector Current-Peak	25	A
I _B	Base Current- Continuous	10	A
I _{BM}	Base Current-Peak	14	A
P _C	Collector Power Dissipation @ T _c =25°C	45	W
T _J	Junction Temperature	150	°C
T _{stg}	Storage Temperature Range	-65~150	°C

SYMBOL	PARAMETER	MAX	UNIT
R _{thj-c}	Thermal Resistance,Junction to Case	2.8	°C/W

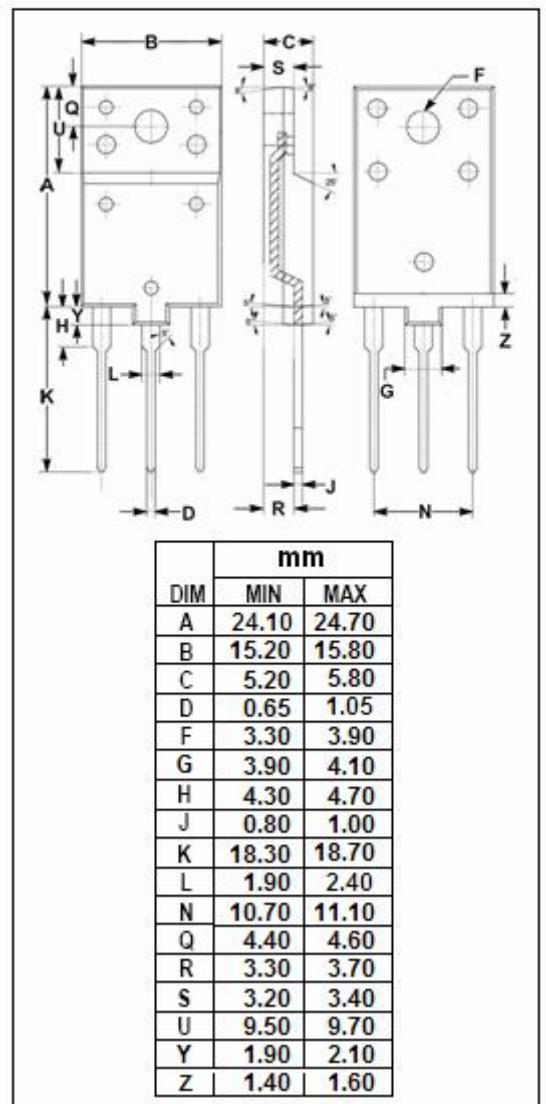
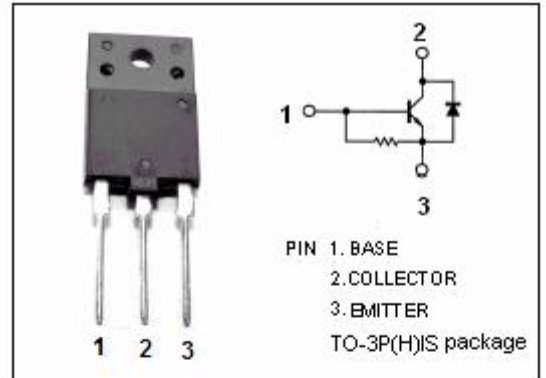

ELECTRICAL CHARACTERISTICS

 $T_C=25^{\circ}\text{C}$ unless otherwise specified

SYMBOL	PARAMETER	CONDITIONS	MIN	TYP.	MAX	UNIT
$V_{(BR)EBO}$	Emitter-Base Breakdown Voltage	$I_E=600\text{mA}; I_C=0$	7.5			V
$V_{CE(sat)}$	Collector-Emitter Saturation Voltage	$I_C=5.5\text{A}; I_B=1.38\text{A}$			1.0	V
$V_{BE(sat)}$	Base-Emitter Saturation Voltage	$I_C=5.5\text{A}; I_B=1.38\text{A}$			1.0	V
I_{CES}	Collector Cutoff Current	$V_{CE}=1600\text{V}; V_{BE}=0$ $V_{CE}=1600\text{V}; V_{BE}=0; T_C=125^{\circ}\text{C}$			1.0 2.0	mA
h_{FE-1}	DC Current Gain	$I_C=1\text{A}; V_{CE}=5\text{V}$		19		
h_{FE-2}	DC Current Gain	$I_C=5.5\text{A}; V_{CE}=1\text{V}$	4		7.5	
V_{ECF}	C-E Diode Forward Voltage	$I_F=5.5\text{A}$		1.6		V