

# Miniature Waterproof Plastic Connectors

## HR30 Series



### Mated dimensions

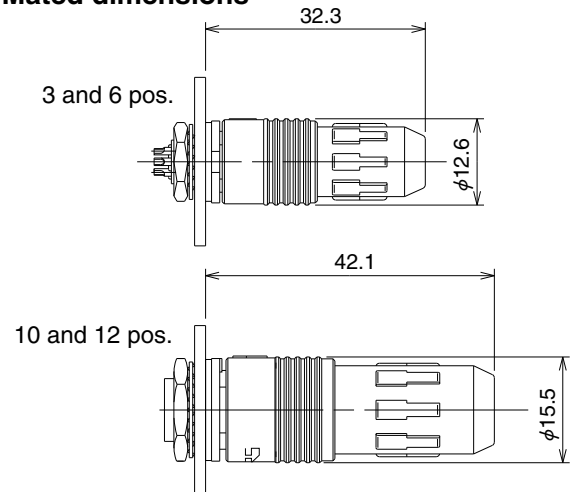

Fig.1

## ■ Features

### 1. Small-size with low profile

3, 6 contacts : Maximum outer diameter  $\phi$ 12.6mm  
Mated length 32.3mm (from the panel surface)

10, 12 contacts : Maximum outer diameter  $\phi$ 15.5mm  
Mated length 42.1mm (from the panel surface)

These small, compact connectors offer unique features available only from Hirose.

### 2. Waterproof construction

IPX7 and IPX8 waterproof construction in the mated state

IPX7 : Left submerged in water at a depth of 1m for 30 minutes

IPX8 : Left submerged in water at a depth of 2m for 14 days

### 3. Push/pull lock

Waterproof connectors feature an easy to operate push/pull locks developed with our exclusive technology.

### 4. Light weight

3 and 6 contacts : 6g (plug + receptacle)

10 and 12 contacts : 9g (plug + receptacle)

### 5. Clamp structure

Our proprietary clamping method allows clamping the cable by simply tightening the cord ring.

### 6. Easy mating operation

The plug can be securely locked while holding it in your hand while mating. (Fig.2)

### 7. Mis-insertion prevention

Mating portions are polarized to avoid improper mating and connector damage.

### 8. Mating mark

Both the plug and the receptacle feature a white index mark on them which is used to quickly align the two interfaces for proper mating.(Fig.3)

### 9. Complies with the RoHS requirements

In consideration of environmental issues, we use only materials that comply with the RoHS Directive.

### Lock/release operation

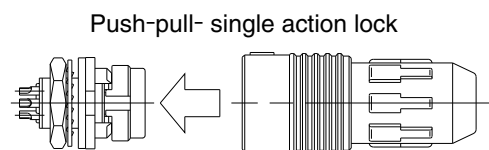

Fig.2



Fig.3

## 10. High speed transmission

Supports Cat. 5e(1Gbps) high speed Ethernet

- Based on ISO TR 11801-9902 Class D3 - Conn E3(End-to-End)
- Characteristics depend on pin assignment, cable specifications and cable assembly conditions. Please check prior to use.
- Please contact a Hirose representative for questions on the recommended pin assignment.

## 11. Suited for long-term outdoor use

Sunshine weather meter test performed for 2,000 hours.  
For details, please contact us for the test reports.

## ■ Product Specifications

Ratings	Current rating	5A (3 pos.) 2A (6,10,12 pos.)	Operation Temperature Range	-25°C to +85°C
	Voltage rating	100V AC,140V DC(3,6 pos.) 30V AC,42V DC(10,12 pos.)	Storage Temperature Range	-10°C to +60°C

Characteristic	Specification	Conditions
1.Contact resistance	5mΩ max. (3 pos.) 15mΩ max. (Solder type : 6, 10, and 12 pos.) 30mΩ max. (Through hole type: 6 and 12 pos.)	1A DC
2.Insulation resistance	1000MΩ min.	100V DC
3.Withstanding voltage	No flashover or insulation breakdown	300V AC / 1minute
4.Vibration	No electrical discontinuity of 10μs or more	Frequency : 10 to 55 Hz, single amplitude of 0.75mm, 1 cycle= 5min, 10 cycles in each of the 3 directions.
5.Durability (mating/un-mating)	Contact resistance 10mΩ min.(3 pos.) Contact resistance 30mΩ min. (Solder type: 6, 10, and 12 pos.) Contact resistance 100mΩ min. (Through hole type: 6 and 12 pos.)	1000 cycles
6.Temperature cycle	Insulation resistance 100MΩ min.	(-55°C : 30 minutes → Room temperature : 10 to 15 minutes → +85°C : 30 minutes → Room temperature : 10 to 15 minutes) for 5 cycles
7.Humidity resistance	Insulation resistance 10MΩ min. (when humidity high) 100MΩ min. (when dry)	96 hours at temperature of 40°C and humidity of 90% to 95%
8.Waterproof performance	No water penetration inside.	While mated with corresponding or protective cap submerged at depth of 1m for half hour.

## ■ Material / Finish

Assembly	Component	Material	Finish	Remarks
Plug	Insulator	PPS	Black	UL94V-0
		PBT	Black	UL94V-0
		Polyacetal	Natural	——
	Gasket	Silicone rubber, chloroprene rubber	Red/Black	——
	Contacts	Brass, phosphor bronze, Copper compound metal	Gold plated	——
Spring	Stainless steel	——	——	
Receptacles	Insulator	PPS	Black	UL94V-0
	Gasket	Chloroprene rubber	Black	——
	Contacts	Brass, phosphor bronze, Copper compound metal	Gold plated	——
	Hexagonal nut	Zinc alloy	Chromate	——
	Washer	Phosphor bronze	Nickel plated	——
Crimp contact (male/female)	Contacts	Phosphor bronze	Selective gold plated	——

## ■ Product Number Structure

Refer to the chart below when determining the product specifications from the product number.  
Please select from the product numbers listed in this catalog when placing orders.

HR30 - 6 P A - 6 S C (\* \*)

<p>① Model name : HR30</p> <p>② Shell size : Outside diameter/plug mating side</p> <p>③ Connector type : P : Plug R : Receptacle J : Jack</p> <p>④ Variation Blank : Standard A : Fine wire B, D : Over mold type</p>	<p>⑤ Number of Contacts : 3, 6, 10 and 12</p> <p>⑥ Contact type S : Female contact P : Male contact</p> <p>⑦ Contact wiring type Blank : Solder C : Crimping D : Through hole</p> <p>⑧ Other specifications: A two-digit character is added to indicate other specifications as needed.</p>
---	---

## Plugs

### ● Solder Type

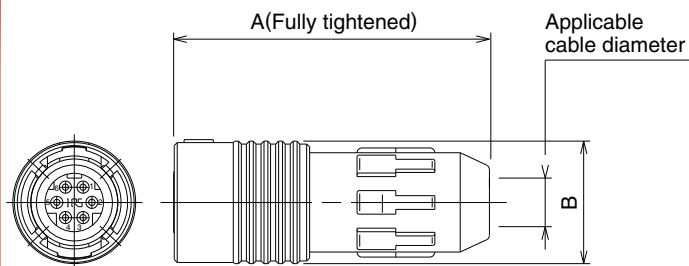

(Representative example)

Part No.	HRS No.	A	B	Applicable cable diameter range	Solder pot inner diameter	Weight
HR30-6P-3S(31)	130-0004-1 31	29.8	12.6	4.2 to 5	1.1 mm	4g
HR30-6P-6S(31)	130-0010-4 31				0.8 mm	
HR30-6P-6P(31)	130-0009-5 31	30.3		3.5 to 4.3	1.1 mm	
HR30-6PA-3S(71)	130-0021-0 71	29.8			0.8 mm	
HR30-6PA-6S(71)	130-0019-9 71	30.3				
HR30-6PA-6P(71)	130-0020-8 71	30.3				
HR30-7P-12S(71)	130-0027-7 71	39.8	15.5	6.2 to 7	0.6 mm	6.7g
HR30-8P-12P(71)	130-0026-4 71					

### ● Crimp Type

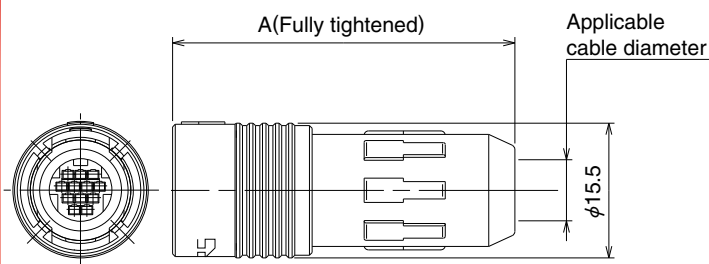

(Representative example)

Part No.	HRS No.	A	Applicable cable diameter range	Crimp contact	Weight
HR30-7P-10SC(71)	130-0013-2 71	39.8	6.2 to 7	HR30-SC-211	6g
HR30-7P-12SC(71)	130-0014-5 71			HR30-PC-211	
HR30-8P-12PC(71)	130-0015-8 71				

## ■ Plug for overmolds

### ● Solder Type

#### HR30-6PB-6S

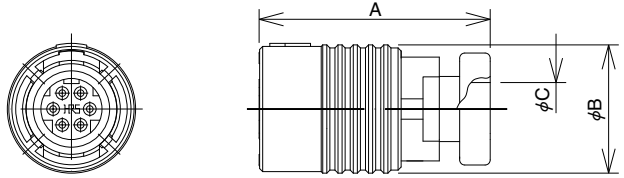

Part No.	HRS No.	A	B	C	Solder pot inner diameter	Weight
HR30-6PB-3S	130-0034-2	22.7	12.6	5.2	1.1 mm	3.1g
HR30-6PB-6S	130-0032-7				0.8 mm	2.9g
HR30-6PD-6P	130-0041-8	23.2				
HR30-7PB-12S	130-0035-5	25.9	15.5	6.4	0.6 mm	4.7g
HR30-8PB-12P	130-0030-1					4.5g

### ● Crimp Type

#### HR30-8PB-12PC

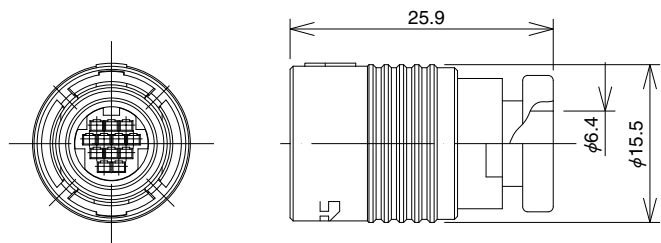

Part No.	HRS No.	Crimp contact	Weight
HR30-7PB-10SC	130-0036-8	HR30-SC-211	4.1g
HR30-7PB-12SC	130-0033-0		
HR30-8PB-12PC	130-0031-4	HR30-PC-211	4.3g

## ■ Receptacles

### ● Solder Type

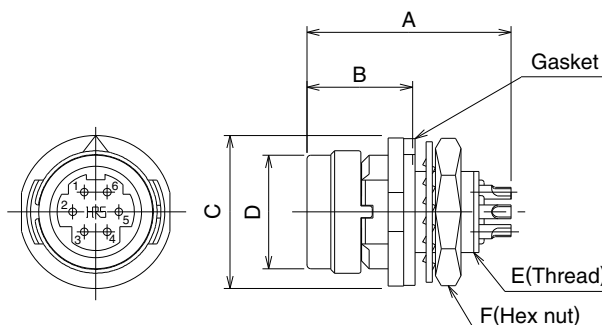
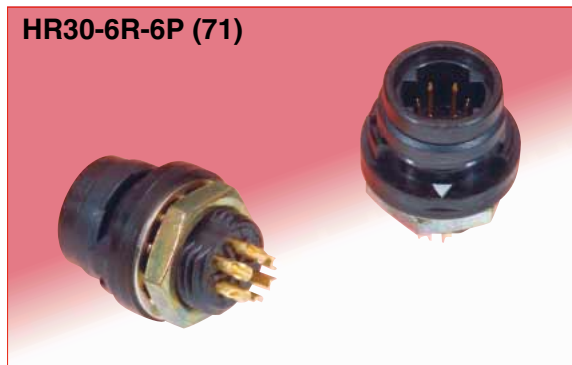

(Representative example)

Part No.	HRS No.	A	B	C	D	E	F	Solder pot inner diameter	Weight
HR30-6R-3P(71)	130-1003-4 71	16	8.3	12	8.9	M8×0.75	10	1.1mm	2g
HR30-6R-6P(71)	130-1009-0 71							0.8mm	
HR30-6R-6S(71)	130-1008-8 71	18.4							
HR30-7R-12P(31)	130-1016-6 31	18.6	9.3	15	11.5	M11×1	13	0.6mm	3.4g
HR30-8R-12S(31)	130-1018-1 31								

### ● Crimp Type

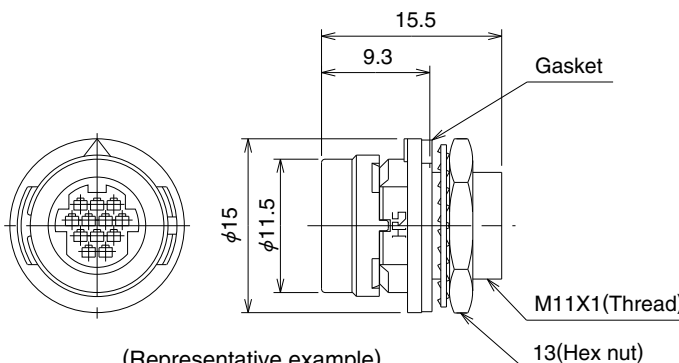

(Representative example)

Part No.	HRS No.	Crimp contact	Weight
HR30-7R-10PC(31)	130-1012-5 31	HR30-PC-211	3g
HR30-7R-12PC(31)	130-1013-8 31		
HR30-8R-12SC(31)	130-1014-0 31	HR30-SC-211	

### ● Through hole Type

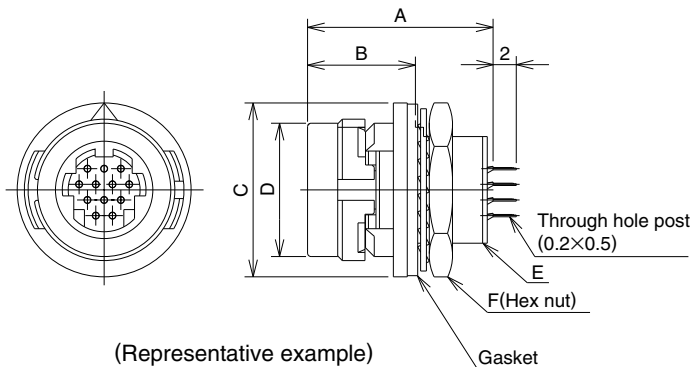

(Representative example)

Part No.	HRS No.	A	B	C	D	E	F	Weight
HR30-6R-6PD(71)	130-1020-3 71	14.9	8.3	12	8.9	M8×0.75	10	2g
HR30-6R-6SD(71)	130-1021-6 71	15.2						
HR30-7R-12PD(31)	130-1017-9 31	16	9.3	15	11.5	M11×1	13	3.4g
HR30-8R-12SD(31)	130-1019-4 31							

Oct. 1. 2024 Copyright 2024 HIROSE ELECTRIC CO., LTD. All Rights Reserved.

## ■ Jacks

### ● Solder Type

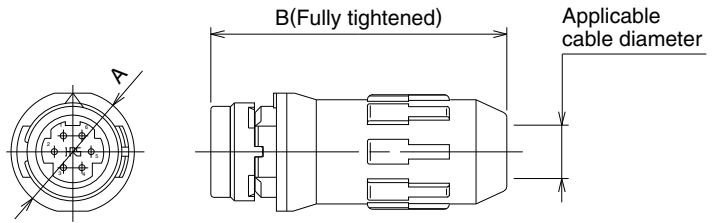

(Representative example)

Part No.	HRS No.	A	B	Applicable cable diameter range	Solder pot inner diameter	Weight
HR30-6J-6P(31)	130-2009-6 31	12	28.8	4.2 to 5	0.8 mm	3g
HR30-6JA-6P(71)	130-2018-7 71			3.5 to 4.3		
HR30-7J-12P(71)	130-2020-9 71	15	37.3	6.2 to 7	0.6 mm	5.7g
HR30-8J-12S(71)	130-2019-0 71					5.9g

### ● Crimp Type

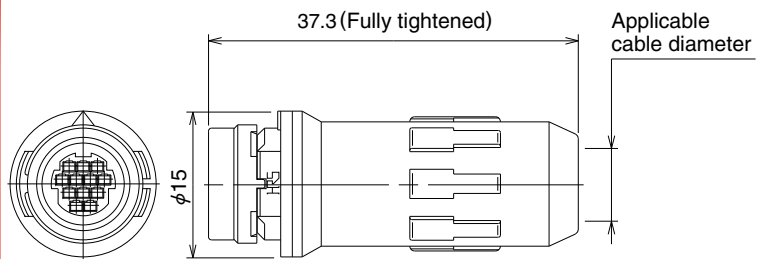

(Representative example)

Part No.	HRS No.	Applicable cable diameter range	Crimp contact	Weight
HR30-7J-10PC(71)	130-2015-9 71	6.2 to 7	HR30-PC-211	5g
HR30-7J-12PC(71)	130-2017-4 71		HR30-SC-211	
HR30-8J-12SC(71)	130-2016-1 71			

## ■ Jack for overmolds

### ● Solder Type

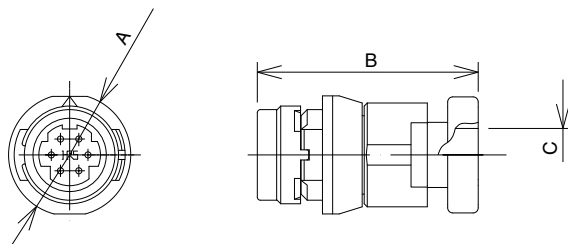

Part No.	HRS No.	A	B	C	Solder pot inner diameter	Weight
HR30-6JB-3P	130-2029-0	12.7	21.7	5.2	1.1mm	2.3g
HR30-6JB-6P	130-2021-1	12			0.8mm	2.2g
HR30-6JB-6S	130-2028-0	12.7			2.3g	
HR30-7JB-12P	130-2023-7	15	23.7	6.4	0.6mm	3.6g
HR30-8JB-12S	130-2024-0					4.1g

### ● Crimp Type

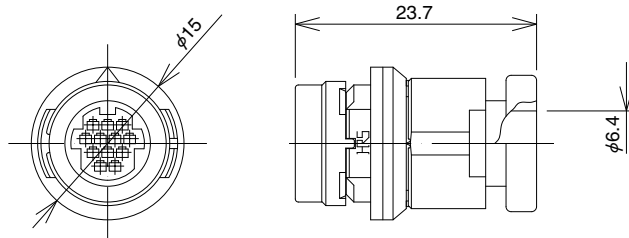

Part No.	HRS No.	Crimp contact	Weight
HR30-7JB-10PC	130-2025-2	HR30-PC-211	3.1g
HR30-7JB-12PC	130-2022-4		
HR30-8JB-12SC	130-2026-5	HR30-SC-211	



## ■ Caps

### ● For Plugs

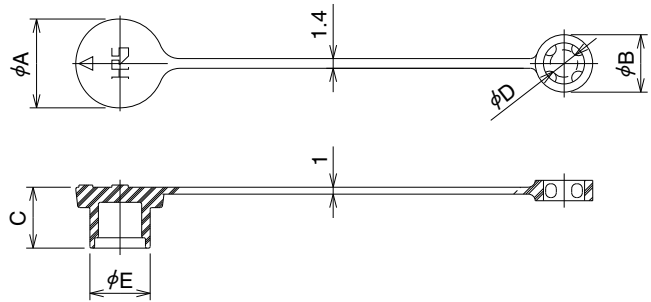

(Representative example)

Part No.	HRS No.	A	B	C	D	E	Applicable cable diameter	Weight
HR30-6P-C(31)	130-3000-7 31	13	8.4	8.9	4	8.8	$\phi 4.2$ to 5	1g
HR30-7P-C(31)	130-3004-8 31	16	10.4	10.5	6	11.4	$\phi 6.2$ to 7	2g
HR30-8P-C(31)	130-3003-5 31							

### ● For Receptacle

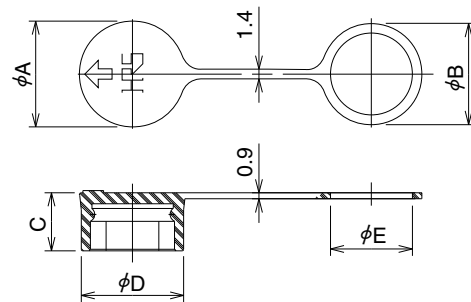

(Representative example)

Part No.	HRS No.	A	B	C	D	E	Remarks	Weight
HR30-6R-C(31)	130-3001-0 31	12.6	11.8	7.5	12.1	9.1	This cap fits each size of the HR30-7R and HR30-8R receptacles	1g
HR30-7R-C(31)	130-3002-2 31	15.5	14.8	8.5	15	12.1		

Note : When using these caps, do not use the gasket that is normally supplied with the receptacle.  
The "B" diameter end of the receptacle cap will serve as the gasket.

## ◆ Crimp Contacts

### Male contact

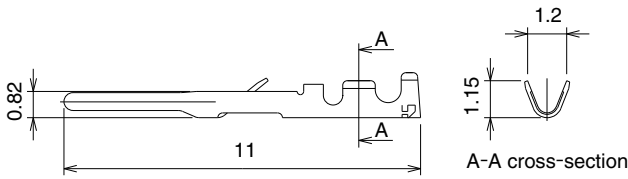

(Representative example)

Type	Part No.	HRS No.	Packaging type	Weight
Loose contact	HR30-PC-111	130-0022-3	100pcs/pack	0.03g/1 pin
Reel contact	HR30-PC-211	130-0016-0	10,000pcs/reel	0.03g/1 pin

### Female contact

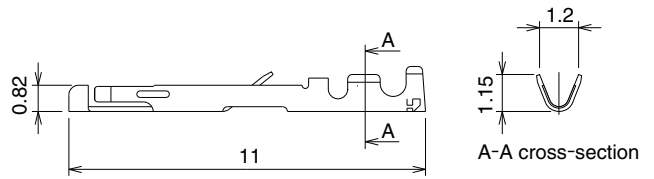

(Representative example)

Type	Part No.	HRS No.	Packaging type	Weight
Loose contact	HR30-SC-111	130-0023-6	100pcs/pack	0.03g/1 pin
Reel contact	HR30-SC-211	130-0017-3	10,000pcs/reel	0.03g/1 pin

Note : Use wire size 26 to 30 AWG with a jacket diameter of 1 mm max.

## ◆ Diagrams of Connectors in Combination

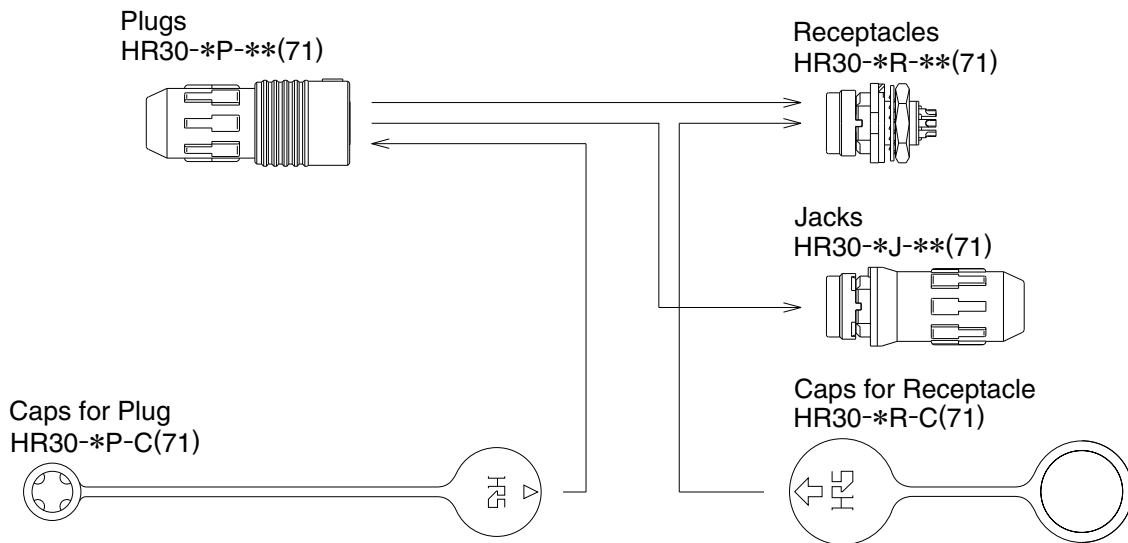

Note 1 : Please use connectors with compatible shell size and number of contacts. If you are using a male contact plug, please also use a corresponding product with a female receptacle and a jack.

Note 2 : Please install the applicable crimping contacts when using the crimping style connectors.  
(Please refer to the manual for wiring work.)

Note 3 : When using the cap on the receptacle side, do not use the gasket that is normally supplied with the receptacle. The Hirose cap has the necessary gasket as part of the cap unit.

## ◆ Cap mounting diagram

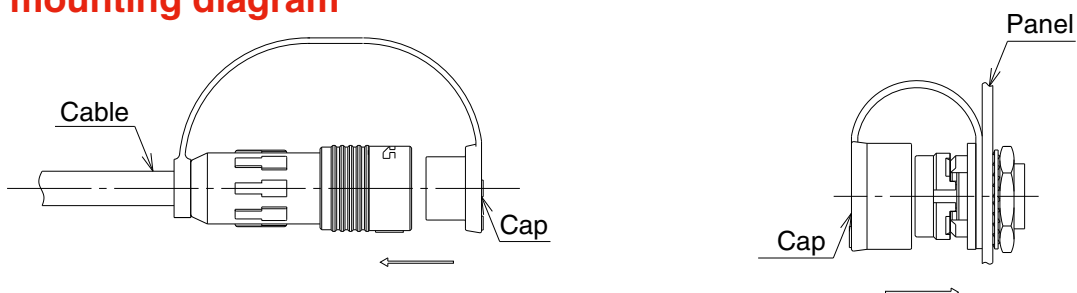

## ◆ Applicable Tools

### ● Cable Assembly Tools

Part No.	HRS No.	Applicable Connectors			
		Shell size	Connector type	No. of contacts	Contact type
HR30-6P-3S-T01	150-0220-1	6	Plug	3	Female
HR30-6P-6S-T01	150-0214-9			6	Female
HR30-6P-6P-T01	150-0221-4				Male
HR30-7P-10SC-T01	150-0228-3	7	Plug	10	Female
HR30-7P-12SC-T01	150-0223-0			12	Female
HR30-8P-12PC-T01	150-0227-0	8	Plug	12	Male
HR30-6R-3P-T01	150-0225-5	6	Receptacle Jack	3	Male
HR30-6R-6P-T01	150-0218-0			6	Male
HR30-6R-6S-T01	150-0222-7				Female
HR30-7J-10PC-T01	150-0231-8	7	Receptacle Jack	10	Male
HR30-7J-12PC-T01	150-0230-5				Male
HR30-8J-12SC-T01	150-0226-8	8		12	Female

Note : Wiring for soldering or disassembly and assembly of plugs and jacks can be accomplished more efficiently when using the cable assembly tool.

### ● Tightening collar for back shell

Part No.	HRS No.	Applicable Connectors
HR30-6P-T02	150-0216-4	3 and 6 contacts
HR30-8P-T02	150-0224-2	10 and 12 contacts

Note : The code ring tightening collar is used to tighten the cord ring to the specified torque.  
(Please refer to the manual for assembly procedures.)



### ◆ Applicable Tools

Type	Description	Part No.	HRS No.	Applicable contact	Applicable wire
Manual	Manual crimping tool	HT-102/HR30-1	150-0229-6	HR30-SC-111	AWG26 to 30
				HR30-PC-111	
Automatic	Automatic crimping machine	CM-105C	901-0001-0	—	—
	Applicator	AP105-HR30-1	901-2015-9	HR30-SC-211 HR30-PC-211	AWG26 to 30
Extraction tool		HR30-TP	150-0219-2	HR30-SC-111	—
				HR30-SC-211	
				HR30-PC-111	—
				HR30-PC-211	

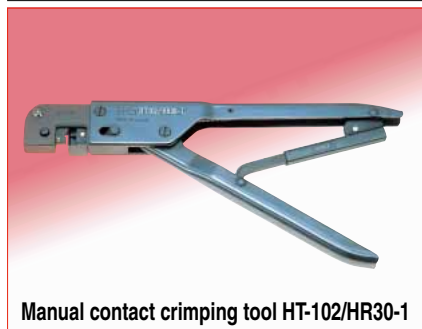

### ◆ Receptacle, Board Mounting Through Hole Pattern

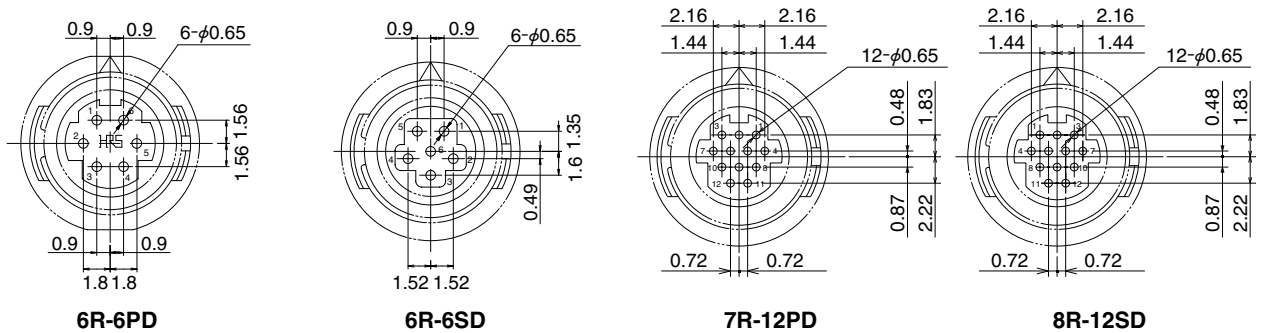

- Remark : 1. The receptacle through hole configuration depicts a view from the mating side of the connector.  
 2. The above  $\triangle$  mark indicates the guide key position.  
 3. The recommended board maximum thickness : 1.2mm.  
 4. Tolerance of +0.03mm is recommended for the plated through hole location. Tolerance of +0.02mm is recommended for the plated through hole diameter.

### ◆ Contact Position Arrangement

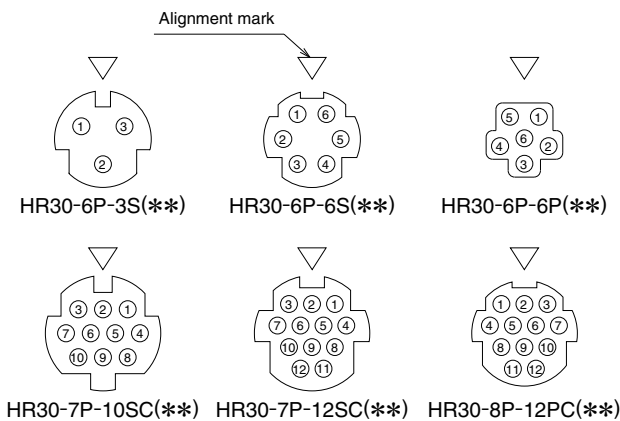

### ◆ Panel Cutout

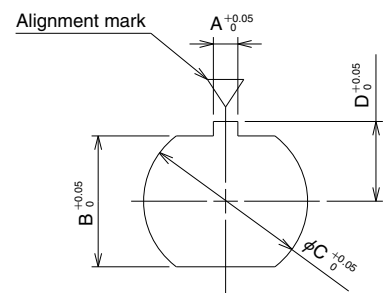

	A	B	C	D	Panel Thickness
3,6 pos.	1.25	6.45	8.05	3.95	0.7 to 2
10,12 pos.	1.35	9.25	11.05	5.45	0.7 to 3

- Remarks : 1. The contact arrangement depicts a view from the wiring side.  
 2. Installation is accomplished by securing the receptacle from the back side of the panel using the supplied hexagon nut. The tightening torque of the hexagon nut should be 0.5 N·m for 3, 6 contacts, and 0.8 N·m for 10, 12 contacts.

In addition, apply Loctite 263 and Lockprimer 7649 which are manufactured by Henkel Japan Ltd., Tokyo in order to prevent looseness.

## ◆ Assembly Procedures

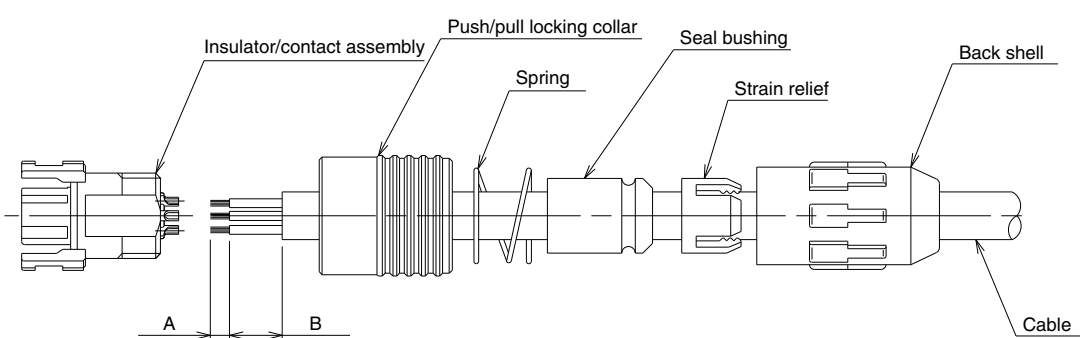
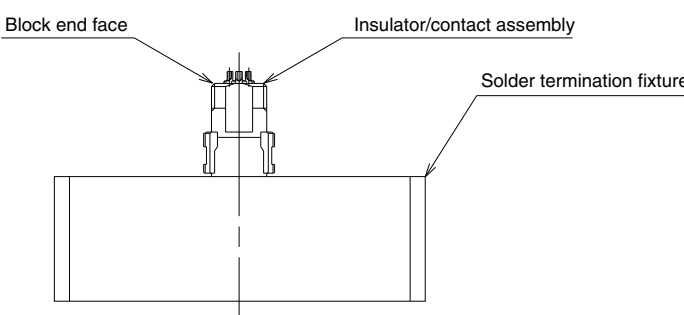
Plug Assembly Sequence														
1		<table border="1" style="width: 100%; border-collapse: collapse; margin-top: 10px;"> <thead> <tr style="background-color: #f2f2f2;"> <th style="width: 60%;"></th> <th style="width: 20%; text-align: center;">A</th> <th style="width: 20%; text-align: center;">B</th> </tr> </thead> <tbody> <tr> <td>Solder type : 3 and 6 Contacts.</td> <td style="text-align: center;">2mm</td> <td style="text-align: center;">5.5mm max.</td> </tr> <tr> <td>Solder type : 12 Contacts.</td> <td style="text-align: center;">2mm</td> <td style="text-align: center;">10mm max.</td> </tr> <tr> <td>Crimp type : 10 and 12 Contacts.</td> <td style="text-align: center;"><math>2 \frac{0}{.5}</math>mm</td> <td style="text-align: center;">15 to 20mm</td> </tr> </tbody> </table>		A	B	Solder type : 3 and 6 Contacts.	2mm	5.5mm max.	Solder type : 12 Contacts.	2mm	10mm max.	Crimp type : 10 and 12 Contacts.	$2 \frac{0}{.5}$ mm	15 to 20mm
	A	B												
Solder type : 3 and 6 Contacts.	2mm	5.5mm max.												
Solder type : 12 Contacts.	2mm	10mm max.												
Crimp type : 10 and 12 Contacts.	$2 \frac{0}{.5}$ mm	15 to 20mm												
<p>Insert the cable in the following order : 1. Back shell, 2. cord clamp, 3. gasket, 4, spring and 5. locking collar. Prepare the cable end according to the dimensions shown in Table 1.</p> <p>Note : When preparing the cable, use caution not to damage the insulation and conductors of the lead wires.</p>														
2		<p><b>Solder type</b></p> <p>Fix the P case block on the cable termination tool, and after preliminary soldering, solder for 3 to 4 seconds with the soldering iron at <math>350 \pm 10^\circ\text{C}</math>.</p> <p>Note 1 : Take care to avoid creating cold solder joints and solder joints with voids or air holes in it. Also check to make sure the solder joint is adequately fused between the lead wires and solder cup.</p> <p>Note 2 : The P case block is a precision unit. Please use caution when soldering the P case block so it does not become damaged. Any damage could result in loss of the waterproof performance.</p> <p><b>Crimp type</b></p> <p>After crimping the appropriate contact to the cable lead wire, insert the terminated wire into the correct contact position on the P case block.</p> <p>Note : After inserting the crimping wire/contact, slightly pull the lead wire and check if the crimping contact is properly seated into the P case block.</p>												

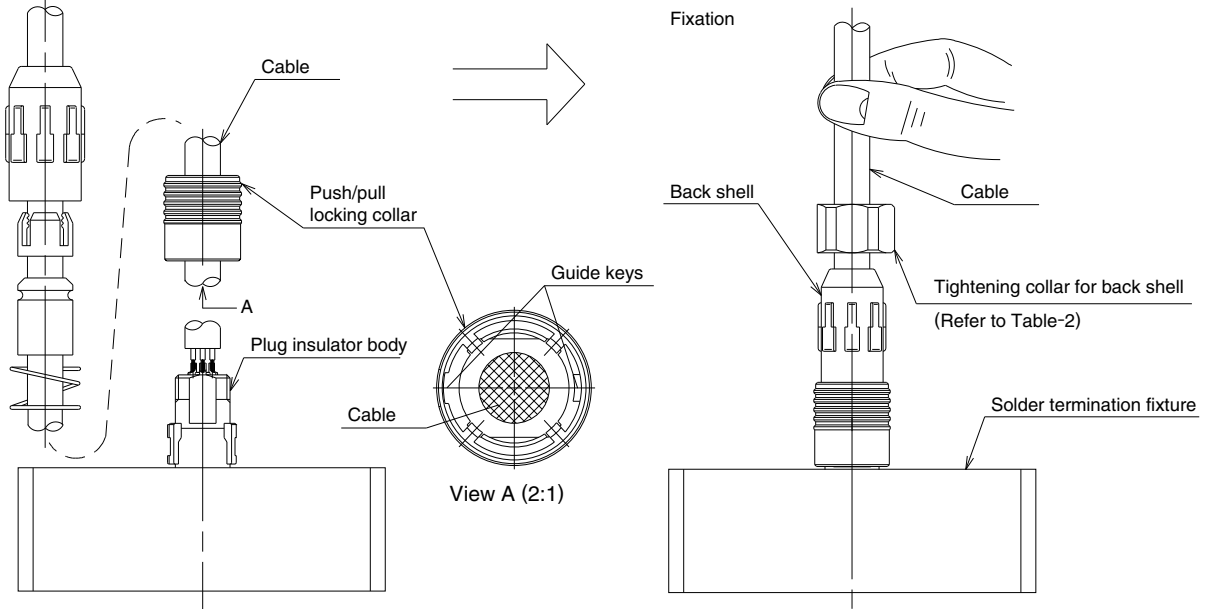

3

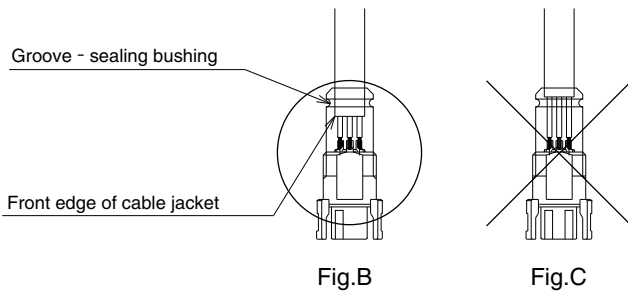

**Table-2**

Connector	Back shell tightening collar size	Torque
3 and 6 Contacts.	16mm	0.5N·m
10 and 12 Contacts.	18mm	0.5N·m

Insert the cable by fitting the coupling guide to the wire-connected P case block.

Then, pass the cable through and assemble in the following order: 1. spring, gasket, 2 cord clamp, and 3. cord tube. Make sure when assembling it with the cord clamp and cord tube, to maintain the positional relations between the cable sheath end face and the concave area of the gasket as shown in Fig.B.

Note : Please install the cord tube using the cord tube tightening tool with the cord ring tightening torque shown in Table-2.

In addition, apply Loctite 263 and Lockprimer 7649 which are manufactured by Henkel Japan Ltd., Tokyo in order to prevent looseness.

When screwing in the cord tube, use your hand to hold the cable so that the cable will not rotate or twist and apply stress to the soldered wires. However, as the cable tends to be twisted slightly (just over one rotation), we recommend that you twist it in the opposite direction in advance.

## ◆ Points to note when using Heat shrink tubing

We recommend that you use shrink tubing over the solder connections in order to protect the soldered wires and to enhance insulation. However, please be careful when applying heat in this area when installing the shrink tube so excess heat does not bleed into or affect the resin parts as shown in the figure below.

If the product does become heated beyond the area shown and into the resin parts, please make sure to prevent the following.

- ① Deformation of the C ring. This could result in prevention of locking during mating.
- ② Melting of some parts.

To prevent the deformation of the C rings of the receptacles and the jack, we recommend heat to be applied after mating with a compatible plug.

Before heating, please mate the plug in the receptacle securely, then pull the back shell for checking whether it is locked properly. If it is heated with semi-fitting, C ring may be thermally deformed with shrinking condition and it may not be locked properly.

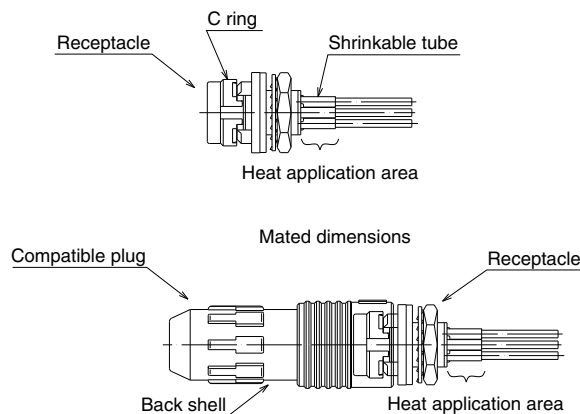

## ◆ Precautions after wiring (Solder type and Crimp type)

After wiring, do not seal the connected portion with potting, etc.

Potting may cause the O-ring to come off when the applicable plug is removed.

If the connector is used with the O-ring removed, the waterproof performance will not be satisfied.

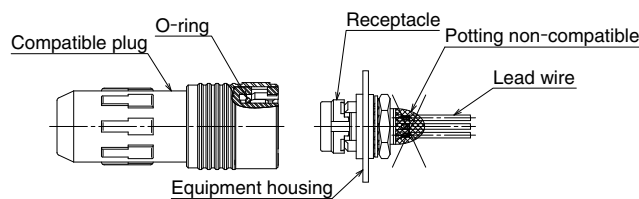

## ◆ General usage notes

1. Mating	2. Un-mating
<p>When mounting, smooth mating will be achieved by holding plug in any are “A” and aligning the arrow of the plug with that of the receptacle, then pushing the plug straight in.</p>	<p>When removing the plug from its connected condition, hold the plug by push/pull locking collar (area “B”) and pull straight off.</p>

## ◆ Precautions

1. Make sure the power is off before mating or un-mating the connector.
2. When mating the connector, push it on with a force of a least 30N.  
After mating, pull slightly on the connector to check for proper mating and to ensure the connector is firmly locked to the receptacle.
3. After mating the connector, do not apply a force over 30N to the cable in the directions shown by the arrows. An excessive load can lead to connector damage.

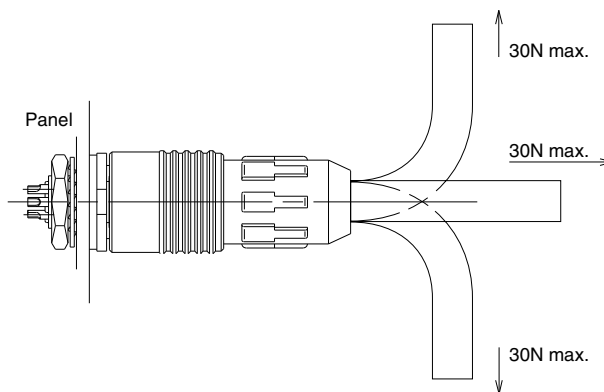

4. To maintain the waterproof performance, cable clamping force and cable stability, please use a cable within the recommended for cable diameters.  
Because the performance will differ depending on the cable structure, make sure to check all specifications of the cable assembly before use or production.
5. Please assemble and install the connector and components with the specified tightening torque.  
If the tightening torque is too weak or too strong, loosening or breakage can occur.
6. Please contact Hirose if your application requires compliance with the Electrical Appliance and Meterial Safety Act.
7. Please note that the white label on the connector may come off due to solvents such as alcohol.

# HIROSE ELECTRIC CO.,LTD.

2-6-3,Nakagawa Chuoh,Tsuzuki-Ku,Yokohama-Shi 224-8540,JAPAN  
<https://www.hirose.com/>