

SPTECH Silicon PNP Power Transistor

BD540

DESCRIPTION

- DC Current Gain -
: $h_{FE} = 40(\text{Min.}) @ I_C = -0.5A$
- Collector-Emmitter Breakdown Voltage-
: $V_{(BR)CEO} = -40V(\text{Min})$
- Complement to Type BD539

APPLICATIONS

- Designed for use in medium power linear and switching applications.

ABSOLUTE MAXIMUM RATINGS($T_a=25^\circ\text{C}$)

SYMBOL	PARAMETER	VALUE	UNIT
V_{CBO}	Collector-Base Voltage	-40	V
V_{CEO}	Collector-Emmitter Voltage	-40	V
V_{EBO}	Emmitter-Base Voltage	-5	V
I_C	Collector Current-Continuous	-5	A
P_C	Collector Power Dissipation @ $T_a=25^\circ\text{C}$	2	W
	Collector Power Dissipation @ $T_c=25^\circ\text{C}$	45	
T_J	Junction Temperature	150	$^\circ\text{C}$
T_{stg}	Storage Temperature Range	-65~150	$^\circ\text{C}$

THERMAL CHARACTERISTICS

SYMBOL	PARAMETER	MAX	UNIT
$R_{th\ j-c}$	Thermal Resistance, Junction to Case	2.78	$^\circ\text{C/W}$
$R_{th\ j-a}$	Thermal Resistance, Junction to Ambient	62.5	$^\circ\text{C/W}$

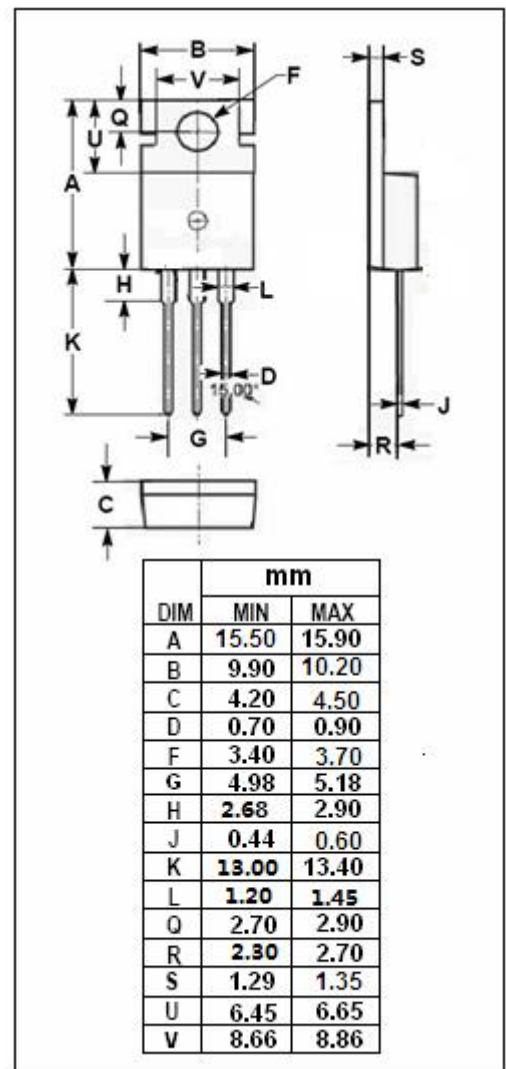
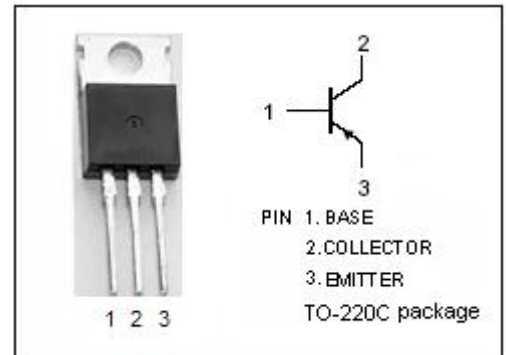

ELECTRICAL CHARACTERISTICS

$T_C=25^{\circ}\text{C}$ unless otherwise specified

SYMBOL	PARAMETER	CONDITIONS	MIN	MAX	UNIT
$V_{(BR)CEO}$	Collector-Emitter Breakdown Voltage	$I_C = -30\text{mA}; I_B = 0$	-40		V
$V_{CE(sat)-1}$	Collector-Emitter Saturation Voltage	$I_C = -1\text{A}; I_B = -0.125\text{A}$		-0.25	V
$V_{CE(sat)-2}$	Collector-Emitter Saturation Voltage	$I_C = -3\text{A}; I_B = -0.375\text{A}$		-0.8	V
$V_{CE(sat)-3}$	Collector-Emitter Saturation Voltage	$I_C = -5\text{A}; I_B = -1\text{A}$		-1.5	V
$V_{BE(on)}$	Base-Emitter On Voltage	$I_C = -3\text{A}; V_{CE} = -4\text{V}$		-1.25	V
I_{CEO}	Collector Cutoff Current	$V_{CB} = -30\text{V}; I_B = 0$		-0.3	mA
I_{CES}	Collector Cutoff Current	$V_{CE} = -40\text{V}; V_{BE} = 0$		-0.2	mA
I_{EBO}	Emitter Cutoff Current	$V_{EB} = -5\text{V}; I_C = 0$		-1.0	mA
h_{FE-1}	DC Current Gain	$I_C = -0.5\text{A}; V_{CE} = -4\text{V}$	40		
h_{FE-2}	DC Current Gain	$I_C = -1\text{A}; V_{CE} = -4\text{V}$	30		
h_{FE-3}	DC Current Gain	$I_C = -3\text{A}; V_{CE} = -4\text{V}$	12		