

**SPTECH Silicon NPN Power Transistor**

**BU407**

**DESCRIPTION**

- High Voltage:  $V_{CEV} = 330V(\text{Min})$
- Fast Switching Speed-  
:  $t_f = 750ns(\text{Max})$
- Low Saturation Voltage-  
:  $V_{CE(\text{sat})} = 1.0V(\text{Max}) @ I_C = 5A$

**APPLICATIONS**

- Designed for use in horizontal deflection output stages of TV's and CRT's

**ABSOLUTE MAXIMUM RATINGS( $T_a = 25^\circ\text{C}$ )**

SYMBOL	PARAMETER	VALUE	UNIT
$V_{CBO}$	Collector-Base Voltage	330	V
$V_{CEV}$	Collector-Emitter Voltage	330	V
$V_{CEO}$	Collector-Emitter Voltage	150	V
$V_{EBO}$	Emitter-Base Voltage	6	V
$I_C$	Collector Current-Continuous	7	A
$I_{CP}$	Collector Current-Peak Repetitive	10	A
$I_{CP}$	Collector Current- Peak (10ms)	15	A
$I_B$	Base Current	4	A
$P_C$	Collector Power Dissipation @ $T_C = 25^\circ\text{C}$	60	W
$T_J$	Junction Temperature	150	$^\circ\text{C}$
$T_{\text{stg}}$	Storage Temperature Range	-65~150	$^\circ\text{C}$

**THERMAL CHARACTERISTICS**

SYMBOL	PARAMETER	MAX	UNIT
$R_{th\ j-c}$	Thermal Resistance, Junction to Case	2.08	$^\circ\text{C}/\text{W}$
$R_{th\ j-a}$	Thermal Resistance, Junction to Ambient	70	$^\circ\text{C}/\text{W}$

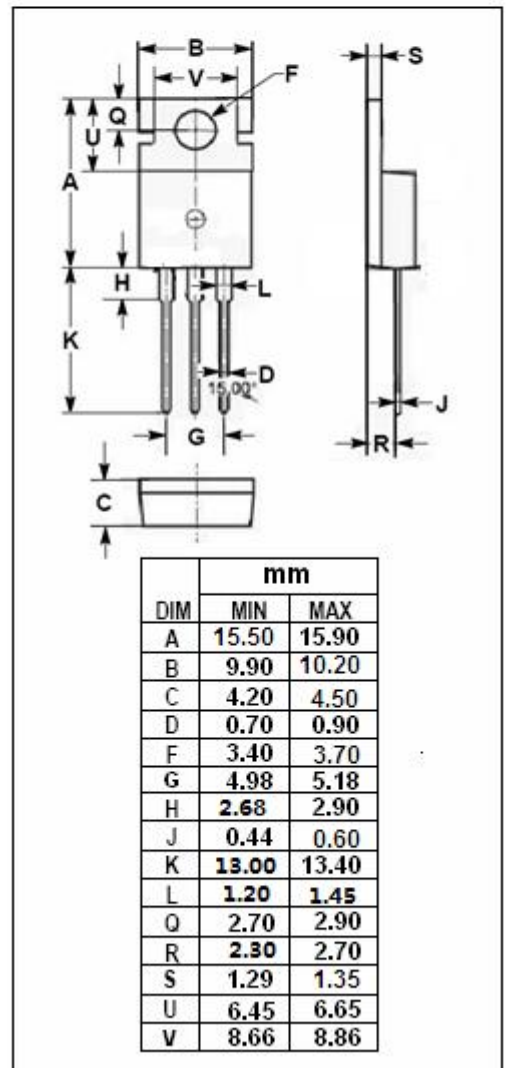
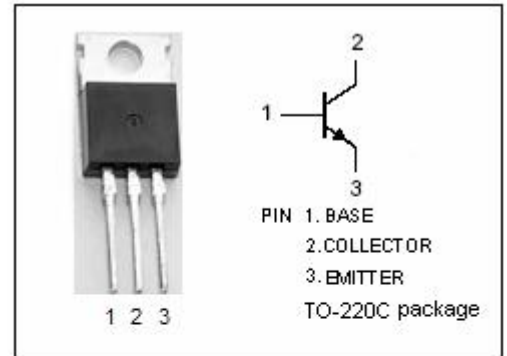

**ELECTRICAL CHARACTERISTICS**

$T_C=25^{\circ}\text{C}$  unless otherwise specified

SYMBOL	PARAMETER	CONDITIONS	MIN	TYP.	MAX	UNIT
$V_{CEO(SUS)}$	Collector-Emitter Sustaining Voltage	$I_C= 50\text{mA} ; I_B= 0$	150			V
$V_{CE(sat)}$	Collector-Emitter Saturation Voltage	$I_C= 5\text{A}; I_B= 0.5\text{A}$			1.0	V
$V_{BE(sat)}$	Base-Emitter Saturation Voltage	$I_C= 5\text{A}; I_B= 0.5\text{A}$			1.2	V
$I_{CES}$	Collector Cutoff Current	$V_{CE}= 330\text{V}; V_{BE}= 0$ $V_{CE}= 200\text{V}; V_{BE}= 0$			5.0 0.1	mA
$I_{EBO}$	Emitter Cutoff Current	$V_{EB}= 6\text{V}; I_C=0$			1.0	mA
$f_T$	Current-Gain—Bandwidth Product	$I_C= 0.5\text{A} ; V_{CE}= 10\text{V}$	10			MHz
$C_{OB}$	Output Capacitance	$I_E= 0; V_{CB}= 10\text{V}; f_{test}= 1.0\text{MHz}$		80		pF
$t_f$	Fall Time	$I_C= 5\text{A}; I_{B1}= -I_{B2}= 0.5\text{A}$			0.75	$\mu\text{s}$