

DESCRIPTION

- High breakdown voltage, and high reliability
- Wide area of safe operation (ASO)
- High-speed switching

APPLICATIONS

- Designed for horizontal deflection output applications.

ABSOLUTE MAXIMUM RATINGS(T_a=25°C)

SYMBOL	PARAMETER	VALUE	UNIT
V _{CBO}	Collector-Base Voltage	1500	V
V _{CEO}	Collector-Emitter Voltage	800	V
V _{EBO}	Emitter-Base Voltage	6	V
I _C	Collector Current-Continuous	20	A
I _{CM}	Collector Current-Pulse	30	A
P _C	Collector Power Dissipation @ T _C =25°C	200	W
T _J	Junction Temperature	150	°C
T _{stg}	Storage Temperature Range	-55~150	°C

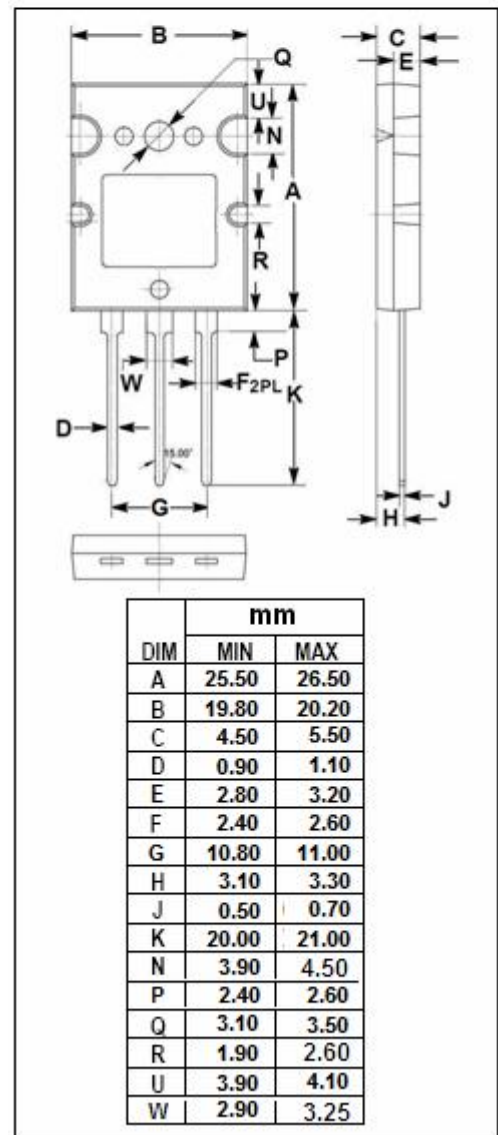
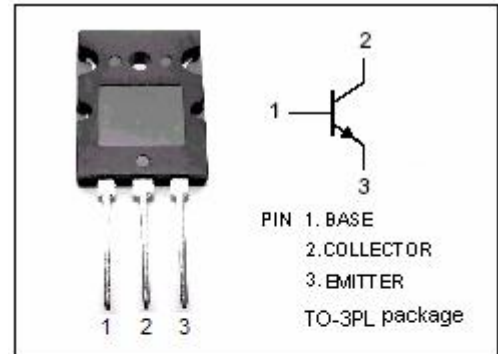

ELECTRICAL CHARACTERISTICS

$T_C=25^{\circ}\text{C}$ unless otherwise specified

SYMBOL	PARAMETER	CONDITIONS	MIN	TYP.	MAX	UNIT
$V_{CE(SUS)}$	Collector-Emitter Sustaining Voltage	$I_C=10\text{mA}; I_B=0$	800			V
$V_{CE(sat)}$	Collector-Emitter Saturation Voltage	$I_C=10\text{A}; I_B=2.8\text{A}$			3.0	V
$V_{BE(sat)}$	Base-Emitter Saturation Voltage	$I_C=10\text{A}; I_B=2.8\text{A}$			1.5	V
I_{CBO}	Collector Cutoff Current	$V_{CB}=1500\text{V}; I_E=0$			1.0	mA
I_{EBO}	Emitter Cutoff Current	$V_{EB}=5\text{V}; I_C=0$			50	μA
h_{FE}	DC Current Gain	$I_C=10\text{A}; V_{CE}=5\text{V}$	5		12	
f_T	Current-Gain—Bandwidth Product	$I_C=0.1\text{A}; V_{CE}=10\text{V}$		3		MHz
t_{stg}	Storage Time	$I_C=12\text{A}, I_{B1}=2.4\text{A}; I_{B2}=-4.8\text{A}$		1.5	2.5	μs
t_f	Fall Time			0.12	0.2	μs