



TO-263-2L Plastic-Encapsulate MOSFETS

CJB130SN10 N-Channel Power MOSFET

V_{(BR)DSS}	R_{DS(on)TYP}	I_D
100V	4.3mΩ@10V	130A

TO-263-2L

1. GATE
2. DRAIN
3. SOURCE

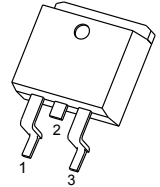

DESCRIPTION

The CJB130SN10 uses shielded gate trench technology and design to provide excellent R_{DS(ON)} with low gate charge. It can be used in a wide variety of applications

FEATURES

- Low R_{DS(on)}
- Low Gate Charge

APPLICATIONS

- High efficiency power supply
- Secondary synchronus rectifier

MARKING

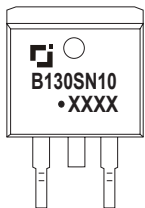

B130SN10 = Device code.
 Solid dot = Green molding compound device,
 if none, the normal device.
 XXXX = Code.

EQUIVALENT CIRCUIT

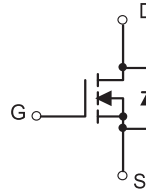

MAXIMUM RATINGS (T_a=25°C unless otherwise noted)

Parameter	Symbol	Limit	Unit
Drain-Source Voltage	V _{DS}	100	V
Gate-Source Voltage	V _{GS}	±20	V
Continuous Drain Current	I _D ①	130	A
Pulsed Drain Current	I _{DM} ②	390	A
Single Pulsed Avalanche Energy	E _{AS} ③	600	mJ
Power Dissipation	P _D ①	250	W
Thermal Resistance from Junction to Ambient	R _{θJA} ⑥	62.5	°C/W
Thermal Resistance from Junction to Case	R _{θJC} ①	0.5	°C/W
Operating Junction and Storage Temperature Range	T _J , T _{stg}	-55~+150	°C

MOSFET ELECTRICAL CHARACTERISTICS

$T_a=25\text{ }^\circ\text{C}$ unless otherwise specified

Parameter	Symbol	Test Condition	Min	Typ	Max	Unit
Off characteristics						
Drain-source breakdown voltage	$V_{(BR)DSS}$	$V_{GS} = 0V, I_D = 250\mu A$	100			V
Zero gate voltage drain current	I_{DSS}	$V_{DS} = 80V, V_{GS} = 0V$	$T_J = 25\text{ }^\circ\text{C}$		1.0	μA
			$T_J = 125\text{ }^\circ\text{C}$		100	
Gate-body leakage current	I_{GSS}	$V_{DS} = 0V, V_{GS} = \pm 20V$			± 100	nA
On characteristics ④						
Gate-threshold voltage	$V_{GS(th)}$	$V_{DS} = V_{GS}, I_D = 250\mu A$	2.0	3.0	4.0	V
Static drain-source on-state resistance	$R_{DS(on)}$	$V_{GS} = 10V, I_D = 12A$		4.3	5.5	m Ω
Dynamic characteristics ④ ⑤						
Input capacitance	C_{iss}	$V_{DS} = 50V, V_{GS} = 0V, f = 100KHz$		6660	13320	pF
Output capacitance	C_{oss}			821	1642	
Reverse transfer capacitance	C_{rss}			17	34	
Gate resistance	R_g	$f = 1MHz$		3.2		Ω
Switching characteristics ④ ⑤						
Total gate charge	Q_g	$V_{GS} = 10V, V_{DS} = 50V, I_D = 22A$		91	182	nC
Gate-source charge	Q_{gs}			23	46	
Gate-drain charge	Q_{gd}			13	26	
Turn-on delay time	$t_{d(on)}$	$V_{DS} = 50V, I_D = 22A, V_{GS} = 10V, R_G = 2.2\Omega$		28.2		ns
Turn-on rise time	t_r			7.5		
Turn-off delay time	$t_{d(off)}$			81.9		
Turn-off fall time	t_f			20.1		
Drain-Source Diode Characteristics						
Drain-source diode forward voltage	V_{SD} ④	$V_{GS} = 0V, I_S = 20A$			1.3	V
Continuous drain-source diode forward current	I_S ①				130	A
Pulsed drain-source diode forward current	I_{SM} ②				390	A

Notes:

1. $T_C = 25\text{ }^\circ\text{C}$ Limited only by maximum temperature allowed.

2. $P_W \leq 10\mu s$, Duty cycles $\leq 1\%$.

3. EAS condition: $V_{DD} = 50V, V_{GS} = 10V, L = 0.5mH, R_g = 25\Omega$ Starting $T_J = 25\text{ }^\circ\text{C}$.

4. Pulse Test : Pulse Width $\leq 300\mu s$, duty cycle $\leq 2\%$.

5. Guaranteed by design, not subject to production.

6. The value of $R_{\theta JA}$ is measured with the device mounted on 1 in 2 FR-4 board with 2oz. Copper, in a still air environment with $T_a = 25\text{ }^\circ\text{C}$.

Typical Characteristics

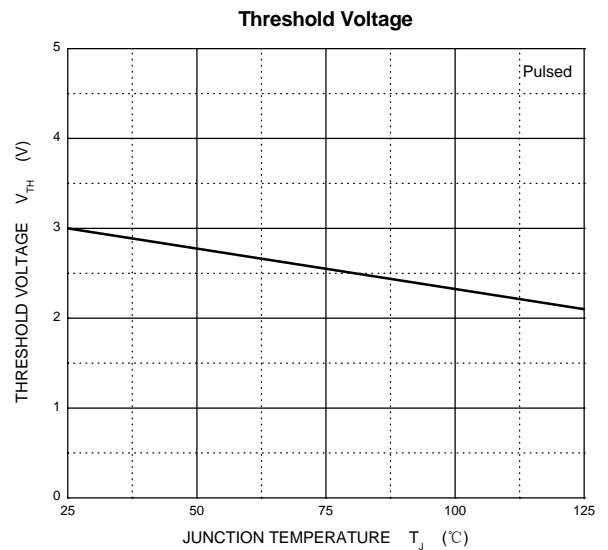
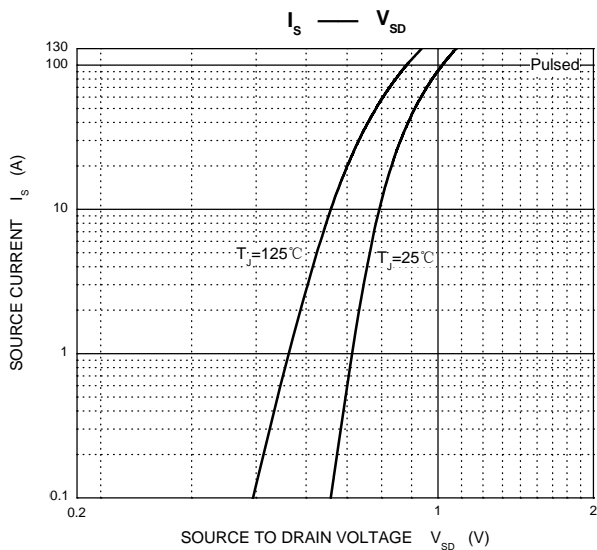
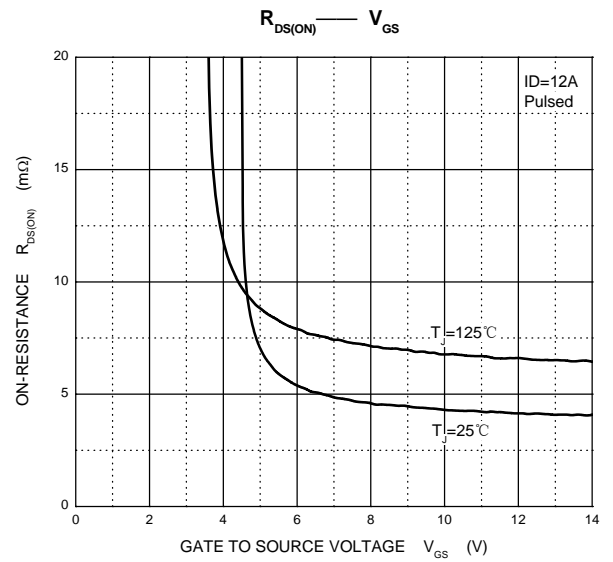
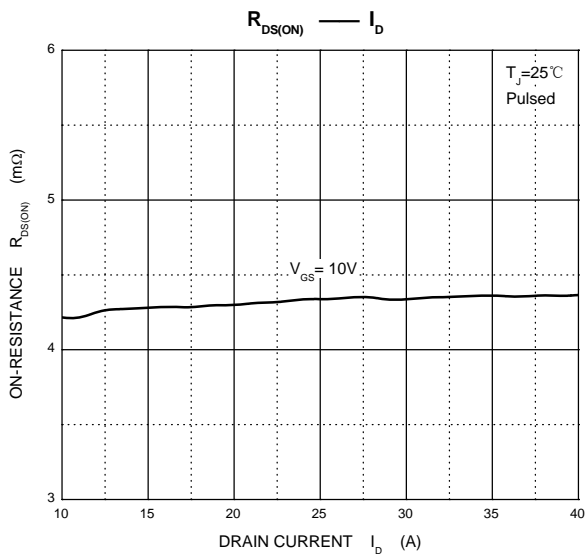
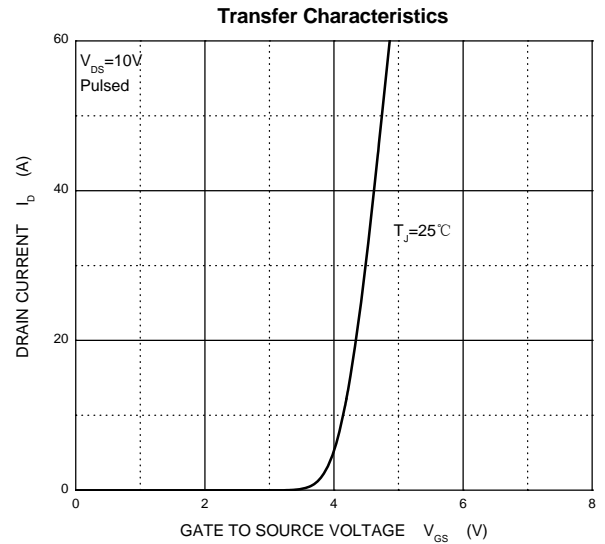
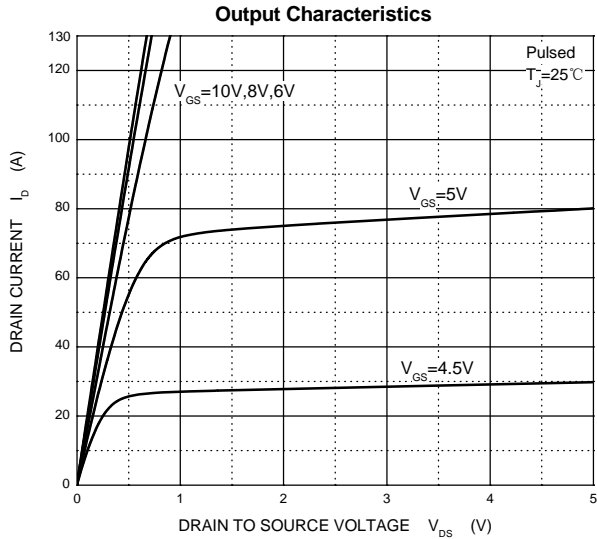

Typical Characteristics

Capacitances

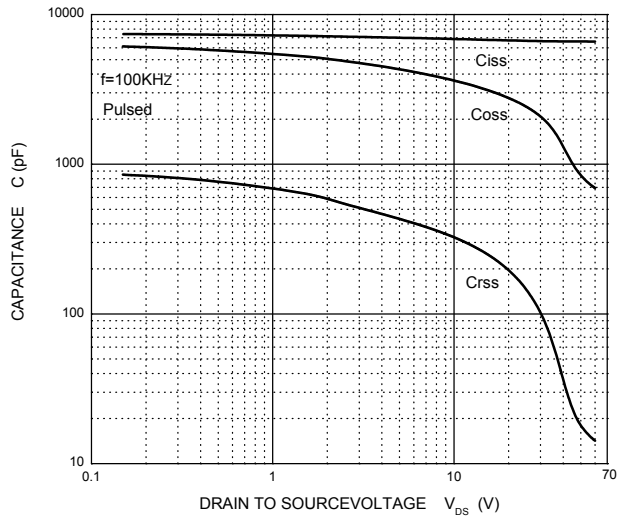

Gate Charge

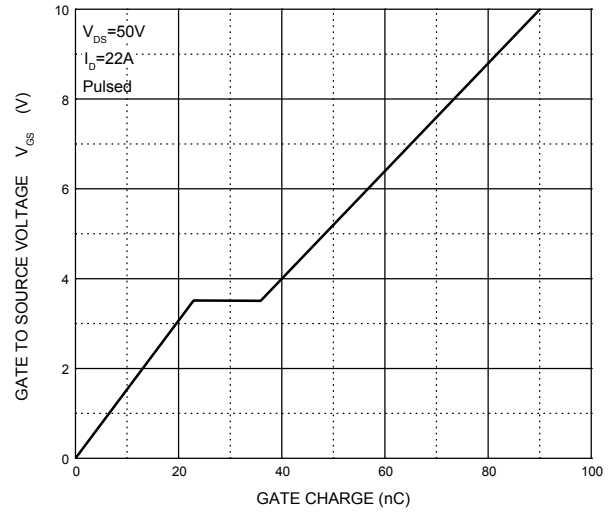

TO-263-2L Package Outline Dimensions

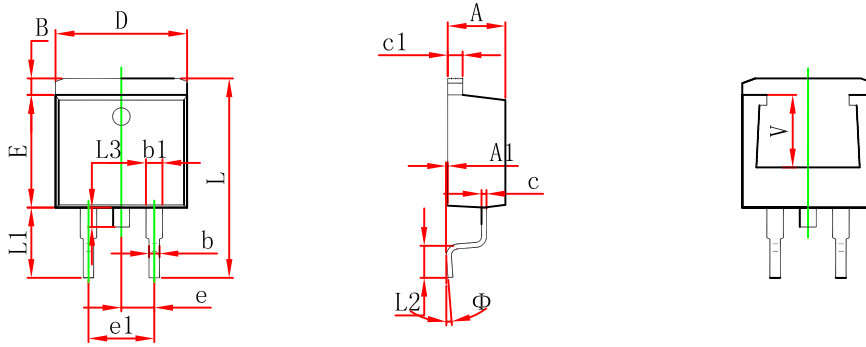

Symbol	Dimensions In Millimeters		Dimensions In Inches	
	Min.	Max.	Min.	Max.
A	4.470	4.670	0.176	0.184
A1	0.000	0.150	0.000	0.006
B	1.120	1.420	0.044	0.056
b	0.710	0.910	0.028	0.036
b1	1.170	1.370	0.046	0.054
c	0.310	0.530	0.012	0.021
c1	1.170	1.370	0.046	0.054
D	10.010	10.310	0.394	0.406
E	8.500	8.900	0.335	0.350
e	2.540 TYP.		0.100 TYP.	
e1	4.980	5.180	0.196	0.204
L	14.940	15.500	0.588	0.610
L1	4.950	5.450	0.195	0.215
L2	2.340	2.740	0.092	0.108
L3	1.300	1.700	0.051	0.067
Φ	0° 8°		0° 8°	
V	5.600 REF.		0.220 REF.	

TO-263-2L Suggested Pad Layout

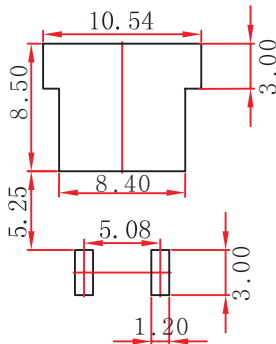

- Note:
1. Controlling dimension: in millimeters.
 2. General tolerance: ± 0.05 mm.
 3. The pad layout is for reference purposes only.

NOTICE

JSCJ reserves the right to make modifications, enhancements, improvements, corrections or other changes without further notice to any product herein. JSCJ does not assume any liability arising out of the application or use of any product described herein.

TO-263-2L Tape and Reel

TO-263-2L Embossed Carrier Tape

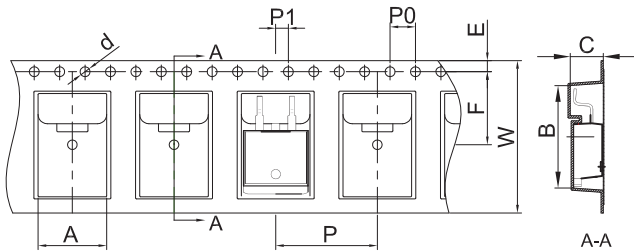

Packaging Description:

TO-263-2L parts are shipped in tape. The carrier tape is made from a dissipative (carbon filled) polycarbonate resin. The cover tape is a multilayer film (Heat Activated Adhesive in nature) primarily composed of polyester film, adhesive layer, sealant, and anti-static sprayed agent. These reeled parts in standard option are shipped with 800 units per 13" or 33.0 cm diameter reel. The reels are clear in color and is made of polystyrene plastic (anti-static coated).

Dimensions are in millimeter										
Pkg type	A	B	C	d	E	F	P0	P	P1	W
TO-263-2L	10.80	16.13	5.21	Ø1.55	1.75	11.50	4.00	16.00	2.00	24.00

TO-263-2L Tape Leader and Trailer

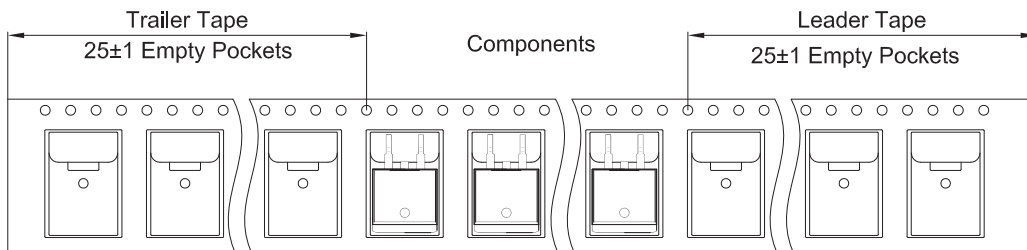

TO-263-2L Reel

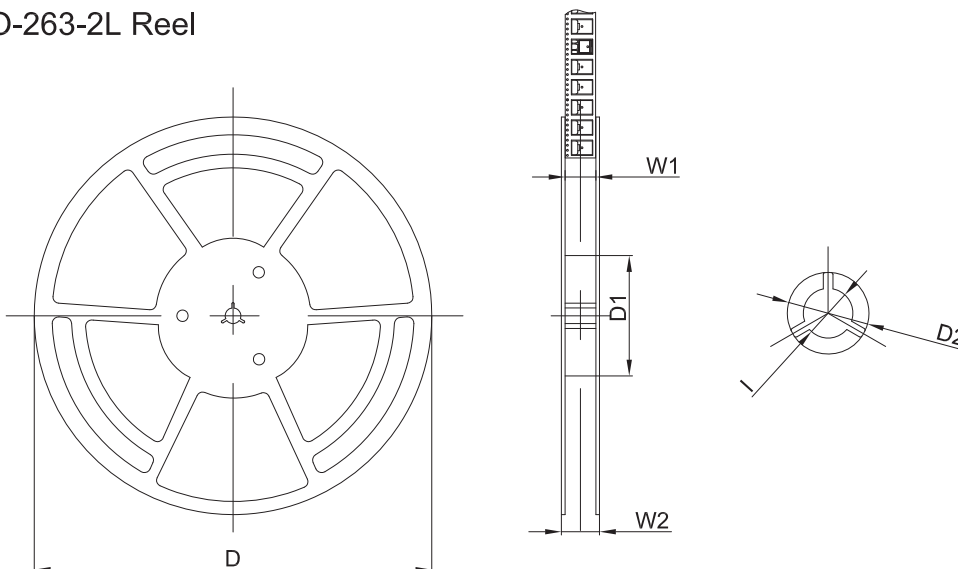

Dimensions are in millimeter						
Reel Option	D	D1	D2	W1	W2	I
13"Dia	Ø330.00	100.00	Ø21.00	24.4	30.4	Ø13.00

REEL	Reel Size	Box	Box Size(mm)	Carton	Carton Size(mm)	G.W.(kg)
800 pcs	13 inch	800 pcs	340×336×36	8,000 pcs	400×353×365	