





# 深圳市强生光电科技有限公司

Shenzhen JNJ Optoelectronics Co., Limited

## 产品规格书

SPECIFICATION FOR APPROVAL

客户名称 Customer	
产品型号 Part No	<b>JNJ-E-TO56F1-0650-005-2P3L6.5-Y1</b>
产品料号 Product No	<b>30102218</b>
版本 Revision	<b>A/3</b>
制作日期 Date	<b>2024-11-04</b>

制作 Producer	工程部 Engineering Dept.	业务部 Business department	批准 Approval
			
客户承认结果 Customer acknowledges Results			

地址：深圳市龙岗区横岗街道 228 工业区永发工业园 48 号 3C 厂区

Address: 3C, No. 48, YongFa Industrial Park, 228 Industrial Zone, HengGang street, LongGang ShenZhen

电话(Tel): 0755-85236381

网站(Web site): <http://www.jnjopto.com>

**外观 Exterior:**



**产品构造 Product conformation:**

- 封装: TO56 封装  
Packaging glue: TO56 encapsulation
- 发光颜色: 波长 650nm  
Luminous color: wavelength 650nm
- 芯片规格: 5mW  
Chip specification: 5mW
- 静电敏感材质  
Electrostatic sensitive material



产品外形尺寸 Package outline dimensions:

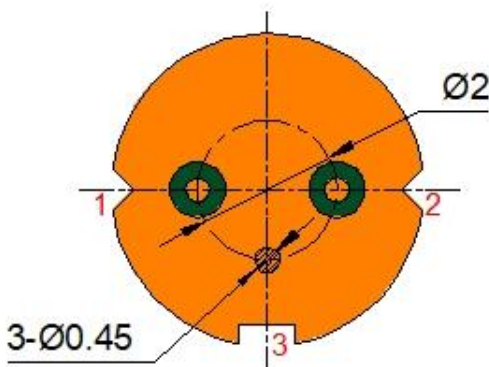
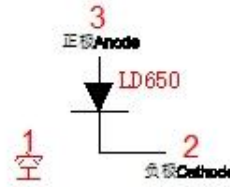
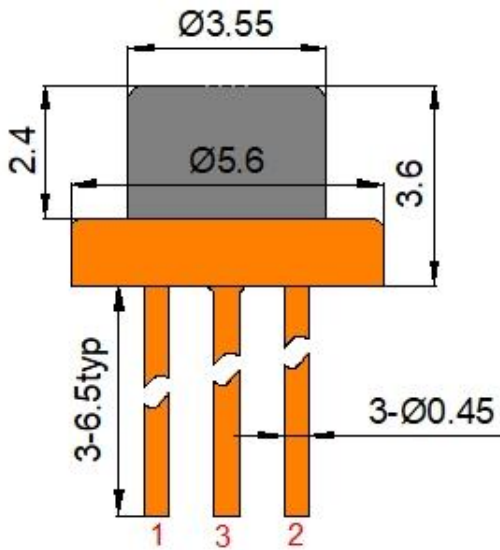
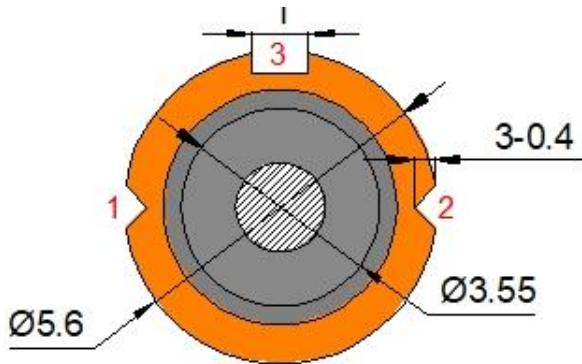

Recommended PCB Lay out

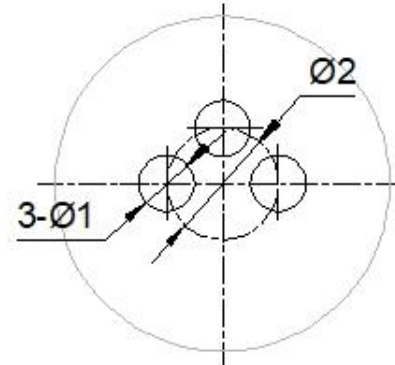

备注(Note):

- 标注尺寸单位为毫米  
Dimensions are in millimeters.
- 除特别标注外，所有尺寸允许公差 $\pm 0.1\text{mm}$ 。  
Tolerances unless mentioned are  $\pm 0.1\text{mm}$ .
- 光学距离：从覆盖玻璃外部观察时的预期距离。在这个位置有一个发射点，并且没有覆盖玻璃。  
Optical Distance: Expected distance when viewed from the outside of cover glass. Please design as there is an emitting point at this position and no cover glass.

**极限参数 Absolute Maximum Rating:**

Parameter		Symbol	Ratings	Unit
Optical output		Po	7	mW
Reverse voltage	LD	Vr	2	V
Operating temp(Tcase).		Top	-20to +70	°C
Storage temp.		Tstg	-40to +85	°C

**光性能特点 Optical Characteristics:**

No.	参数 Parameter	符号 Symbol	测试条件 test condition	最小值 Min.	典型值 Typ.	最大值 Max.	单位 Unit
1	阈值电流 Threshold Current	Ith	---	10	15	---	mA
2	正向电压 Forward Voltage	VF	IF=20mA	---	2.1	2.5	V
3	微分电阻 Differential Resistance	Rs	---	---	75	---	Ohms
4	斜率效率 Slop Efficiency	SE	---	0.5	0.9	---	W/A
5	光功率 Output Power	Lop	IF=20mA	---	5	---	mW
6	转换效率 Power Conversion Efficiency	PCE	IF=20mA	18	20	---	%
7	波长 Wavelength	$\lambda_{op}$	IF=20mA	---	650	---	nm
8	光斑平行角宽 Parallel angles of light spots are wide	$\theta_{//}$	IF=20mA	---	7	12	deg
9	光斑垂直角宽 The spot is perpendicular to a wide angle	$\theta_{\perp}$	IF=20mA	---	36	39	deg
10	驱动限压 Drive pressure limit	V <sub>F</sub>	---	---	---	2.6	V
11	工作电流 working current	I <sub>F</sub>	Po=5mW	---	17	22	mA

**Caution:**

1. Tc=25°C, QCW 模式 (pulse length 0.5ms, 1%Duty Cycle)
2. 发散角  $\theta_{\perp}$  及  $\theta_{//}$  均为半峰宽 (FWHM)

芯片特性曲线 Chip feature curve

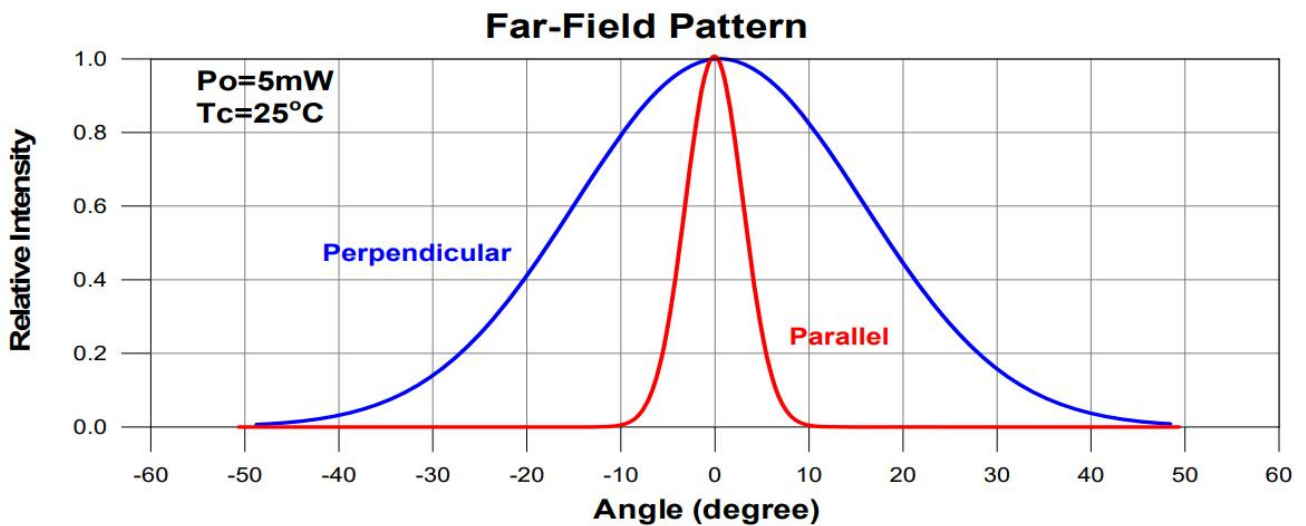
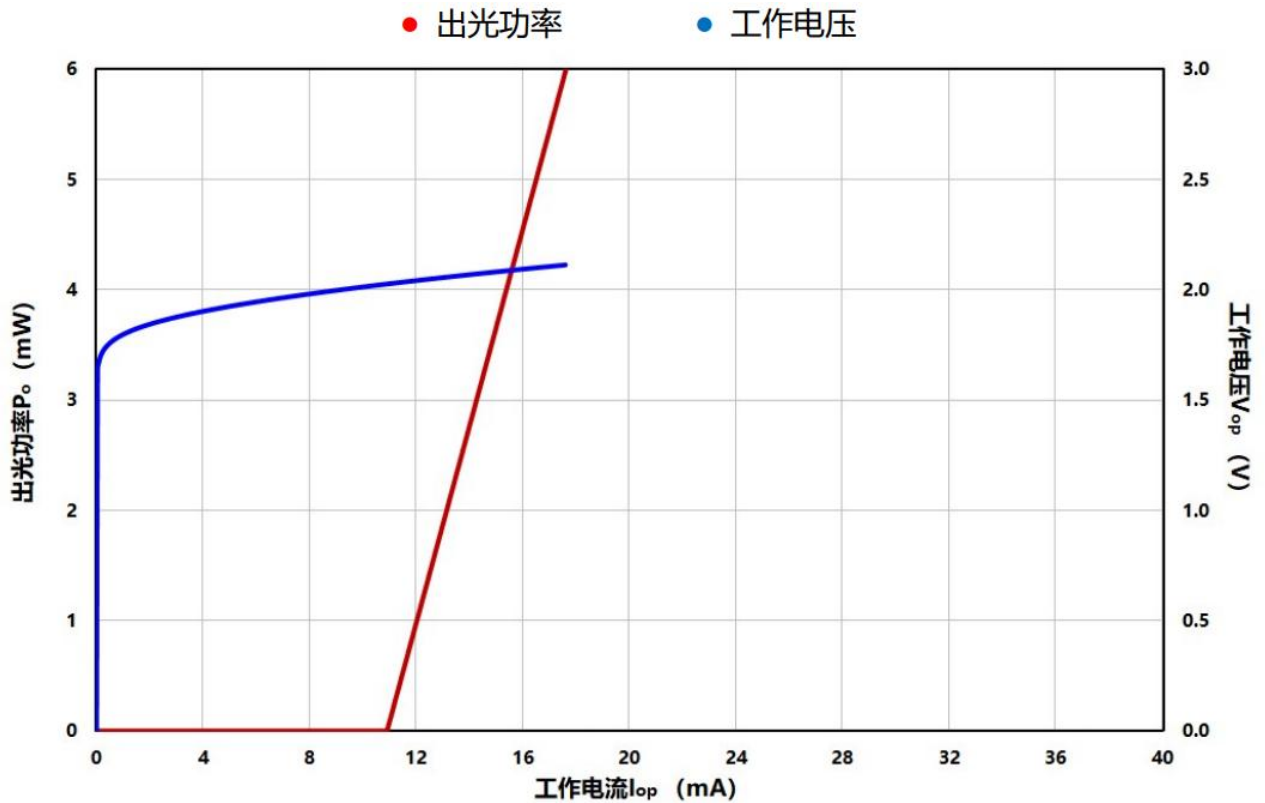

## 使用操作注意事项 Operation notes on use

该装置属于Ⅲ类ⅢⅢⅢⅢb 激光产品，发射可见激光辐射。应避免直接暴露，并且永远不要看发射表面。

**This device is classified as a class III IIIIII IIIb laser product , emitting visible laser radiation.**

**Direct exposure should be avoid and never look at the emitting surface.**

(1) (绝对最大额定值) 如果激光二极管中流动过大电流，将会出现大的光输出，发射面可能遭受损坏。即使有短暂的过电流，也会导致这种光学损伤的发生。因此，即使是瞬间也不能超过的极性参数。请特别注意驱动电压供应和静电供应。我们保证使用在绝对最大评级范围内。这些额定值是针对外壳温度为 25c 而建立的。随着激光二极管温度的升高，其最大输出将降低，工作范围将缩小。即使在绝对最大额定值下运行，高温下运行也会比低温下运行寿命短。因此，设计应包括足够的热辐射和光输出的余量。

(1) (Absolute maximum ratings) If an excessive current flows in a laser diode, a large optical output will occur and the emitting facet may sustain damage. This optical damage can occur even with momentary over-current. For this reason, absolute maximum ratings which must not be exceeded even momentarily have been established. Exercise particular caution with respect to the drive voltage supply and static electricity. We guarantee use within the absolute maximum ratings. These ratings are established for a case temperature of 25°C. As the temperature of laser diode increases, its maximum output will decrease and the operating range will shrink. Even when operated within the absolute maximum ratings, operation at high temperature will result in a shorter life than operation at low temperature. For this reason, the design should include sufficient margin for heat radiation and light output.

(2) (热辐射条件) 和其他半导体一样，激光二极管的长时间运行会导致热量在结处积聚，并增加外壳温度。由于这个原因，连接铝 (或其他) 散热器 (至少 30x30x3mm)到激光器的阀杆上。

(2) (Heat radiation conditions) Like other semiconductors, prolonged operation of a laser diode will cause heat to build up at junctions and increased case temperature. For this reason, attach aluminum (or other) heat sinks (at least 30x30x3mm) to the stem of the laser.

(3) (防止静电放电和其他电流涌造成的损坏) 静电放电和其他电流浪涌会导致激光二极管的退化和损坏，导致可靠性降低。我们建议您采取以下保护措施。

(3) (Protection against damage due to electrostatic discharge and other current surges) Electrostatic discharge and other current surges can cause deterioration and damage in laser diode, resulting in reduced reliability. We advise talking the following protective measures.

①将设备和电路接地。安装浪涌过滤器、减振变压器或其他静电放电器电源输入端中的保护器。

① Ground the device and circuits. Install surge filters, surge reduction transformers, or other electrostatic discharge protectors in the power supply inputs.

②当使用激光二极管时，要穿防静电服装，包括鞋类和帽子。在使用激光二极管时，应始终佩戴接地腕带，陷阱应通过 1Ω电阻接地。

② When working with laser diodes wear anti-static clothing, including footwear and caps. Grounded wrist straps should always be worn while working with laser diodes, and the trap should be grounded through a 1Mohm resistance.

③使用防静电容器进行运输和储存。

③ Use anti-static containers for transport and storage.

④当电源打开或关闭时，电流峰值过多会导致激光损坏和损坏。设计电路，以避免产生过大的电流峰值。

④ Laser deterioration and damage can occur due to excessive current spikes when the power is turned on or off. Design circuits to avoid the generation of excessive current spikes.

⑤在发射高频电磁干扰的设备附近的感应浪涌可能会损坏或摧毁激光。避免在荧光灯或其他电磁干扰发射物附近使用激光。

⑤ Inductive surge near equipment that emits high-frequency EMI can damage or destroy lasers. Avoid using lasers near fluorescent lamps or other of EMI emissions.

地址：深圳市龙岗区横岗街道 228 工业区永发工业园 48 号 3C 厂区

Address:3C, No. 48, YongFa Industrial Park, 228 Industrial Zone, HengGang street,LongGang ShenZhen

电话(Tel): 0755-85236381

网站(Web site): <http://www.jnjopto.com>

(4) (焊接) 使用接地焊铁焊接激光导线。在不超过 350 摄氏度的温度下焊接, 最长 3 秒, 距离导线根部至少 2 毫米。

(4) (Soldering) Use a grounded soldering iron to solder laser leads. Solder at a temperature of no more than 350°C for a maximum of 3 seconds, at a point at least 2mm from the root of the leads.

① 请注意以下几点: ① Please be careful to below points.

② 模粘膏的粘附性在高温下显著下降, 因此包装必须始终非常小心地观察温度。请避免加热整个包装, 如回流焊接

② The adhesiveness of the die-bonding paste dramatically declines in high temperature, thus the package temperature must be observed with extreme care at all times. Please avoid heating the whole package such as reflow soldering.

③ 建议一次只加热一个导线框架。(请避免同时加热多个导线。)

③ It is recommended to heat only one lead frame at a time. (Please avoid heating multiple leads simultaneously.)

④ 加热引线框架会导致整个包装温度升高, 因此建议释放在焊接过程中通过散热器进行加热。

④ Heating the lead frame will cause the whole package temperature to rise thus it is recommended to release the package heat by heat sink during soldering.

⑤ 建议先焊接 GND 引线, 以抑制来自引线框架的热传导。

⑤ It is recommended to solder the GND lead first to restrain the heat conduction from the lead frame.

(5) (在使用胶水时), 胶水的挥发成分可能会对激光二极管的特性产生影响。请在充分确认后使用。

(5) (In the use of the glue) There is the possibility that the volatilization component of the glue exerts the influence on the characteristic of laser diode. Please use it after it confirm sufficiently.

(6) (搬运包装) 包装不得跌落或承受过度压力。在成型过程中, 要小心不要给内部导线和切割导线增加应力。永远不要接触激光器的玻璃部分。损坏或 被弄脏的玻璃部件会损害激光器的性能。

(6) (Handling packages) Packages must not be dropped or subjected to excessive pressure. In the forming processing, be careful not to add stress to the inner leads and cut wires. Never touch the glass parts of the laser. A damaged or dirtied glass parts will impair the performance of the laser.

(7) (安全) 直接或通过透镜观察激光发射的激光束是极其危险的二极管。使用电视摄像机或其他类似的设备来调整光轴。

(7) (Safety) It is extremely dangerous to look, either directly or through a lens, at the laser beam emitted from a laser diode. Use a TV camera or other similar device to adjust the optical axis.

## [使用该激光二极管的限制] 【Restrictions for using this Laser Diode】

地址: 深圳市龙岗区横岗街道 228 工业区永发工业园 48 号 3C 厂区

Address: 3C, No. 48, YongFa Industrial Park, 228 Industrial Zone, HengGang street, LongGang ShenZhen

电话(Tel): 0755-85236381

网站(Web site): <http://www.jnjopto.com>

1) 本产品不符合汽车电子元件可靠性标准 AEC-Q102。因此，它不满足汽车使用的质量要求。AEC-Q102 数据适用于样品只来自特定的生产批次，而不是所有的产品。它不应该被视为 AEC-Q102 的正式发布。

1) This product does not comply with the automotive electronic component reliability standard AEC-Q102. Therefore, it does not fulfill the quality requirements for automotive usage. The AEC-Q102 data is applicable for samples from the certain production lots only, not for all products to be delivered in series production. It shall not be regarded as official AEC-Q102 release.

2) 不要将本产品用于(i)任何汽车应用和汽车环境，以及(ii)任何产品，机器或设备（如光通信、燃料控制、各种安全设备、其他设备）与医疗、运输、交通、航空航天和核能控制有关），要求极高可靠性或有可能影响人类生命或造成其他严重损害的。在这种情况下产品，强生不承担任何责任，包括以下 5)至 8)的责任。

2) Do not use this product for (i) any automotive application and automotive environment and (ii) any product, machine, or equipment (such as optical communication, fuel control, various safety equipment, other equipment related to medical, transportation, traffic, aerospace, and nuclear power control) that requires extremely high reliability or has the potential to impact human lives or inflict other serious damages. In such cases that this product is used in these, JNJ will not assume any responsibilities including those stated below from 5) to 8).

3) 强生在客户零件号获取和认证时提供的文件和数据 将采用强生的标准格式。

3) Documents and data provided by JNJ at the time of the customer's part number acquisition and certification will be in JNJ's standard format.

4) 强生不承担任何责任和通信，除非在下文第 5)至第 8)条中明确说明。在这种情况下强生不对应的项包括①到⑥，但不限于它们。

4) JNJ assumes no responsibility and correspondence unless explicitly stated in 5) to 8) below. In this case, the items that JNJ will not correspond to includes ① to ⑥ but are not limited to them.

①在本产品认证等场合与客户进行联合设计评审。

① Joint design reviews with customers for occasions such as certification of this product.

②由客户领导的质量改进活动（包括零缺陷研究，包括但不限于此）。

② Quality improvement activities led by customers (zero defect research included but not limited to this).

③按批次分类或交换本产品。

③ Sorting or exchanging of this product by lot.

④采取了抑制不合格项和缺陷的发生和扩散的措施。

④ Measures to restrain the occurrence and spread of non-conformity and defects.

⑤在客户的产品上安装和拆卸本产品。

⑤ Mounting and dismounting of this product on customers' products.

⑥支持本产品的任何外观缺陷。

⑥ Supporting of any appearance defects of this product.

如果在交付时发现本产品不符合本规范，或发生故障在使用该产品的制造过程中，强生判断该缺陷明显可归因于本产品，我们将只把有缺陷/不合格的零件换成好的零件。

If it is found that this product does not conform to this specification at the time of delivery, or if a failure occurs in the manufacturing process using this product, and JNJ judges that the defect is obviously attributable to this product, we will only exchange the defective / non-conformed parts to good ones.

5) 如果 JNJ 确定在安装了本产品的任何产品、机械或设备（以下简称“应用程序”）中发生的故障显然是由本产品造成的，JNJ 将对返回的产品进行产品分析。但是，如果无法确定原因，将不会进行进一步的调查。

5) In the event that JNJ determines that a failure occurring in any product, machinery or equipment (hereinafter referred to as "application") with this product installed, is obviously attributable to this product, JNJ will conduct a product analysis of the returned product. However, if the cause cannot be identified, additional investigations will not be conducted.

6) 只有在本产品应用于本规范范围内，并且从同一 JNJ 装配批次中检测到三个或三个以上的不合格/缺陷产品时，才会进行应急响应。应急响应的内容将由与客户协商后决定。

地址：深圳市龙岗区横岗街道 228 工业区永发工业园 48 号 3C 厂区

Address: 3C, No. 48, YongFa Industrial Park, 228 Industrial Zone, HengGang street, LongGang ShenZhen

电话(Tel): 0755-85236381

网站(Web site): <http://www.jnjopto.com>



- 6) Only in the event that this product is used on applications, is within the scope of this specification, and three or more non-conforming/defective products are detected from the same assembly lot of JNJ, an emergency response will be conducted. The contents of the emergency response will be decided upon consultation with the customer.
- 7) 如果客户对本产品进行了分析和/或调查，并发现有不符合项，则 损害本产品的初始性能或功能，ROHM 将回复客户的问题和/或 采取措施改进不合格项。
- 7) If the customer conducts an analysis and/or investigation of this product and detects a non-conformity that impairs the initial performance or function of this product, ROHM will reply to the customer's questions and/or take actions to improve the non-conformity.
- 8) 如果强生确定该变更将对产品的性能、功能或可靠性产生重大影响，则将提前 9 个月通知客户对 5M（人员、方法、机器、材料和测量）的变更。。
- 8) Changes to 5M (Men, Method, Machine, Material, and Measurement) will be notified to customers 9 months in advance if JNJ determines that the change will have a significant impact on the product's performance, functions, or reliability.
- 9) 本产品的停用/EOL 将在最后订单截止日期前至少 6 个月和至少在最后发货日前 12 个月收到通知。如果客户在最后的订单截止日期前下了最终的订单，并且 JNJ 接受了，那么强生将支持最后一次购买。强生将发货最终订单的金额，直到最终发货日。然而，JNJ 将支持的最大订单数量仅限于强生的生产能力和可用材料的数量。
- 9) Discontinuation/EOL of this product will be notified at least 6 months before the final order deadline and at least 12 months before the final shipment day. JNJ will support a last time buy if the customer places a final order before the final order deadline and JNJ accepts. JNJ will ship the amount of the final order until the final shipment day. However, the maximum order quantity that JNJ will support is restricted to JNJ's production capacity and the quantity of material available.
- 10) 由于估计该产品使用寿命的可靠性测试是通过抽样检查来完成的，因此不能保证所有产品的能力。
- 10) Since the reliability test to estimate this product's lifetime is done by sampling inspections, the capability of all products are not guaranteed.