

---

# Product Specifications

Type : MS Lithium Rechargeable Battery  
Model : MS621T FL11E

This is a "Standard Spec sheet " which is a general documentation for your evaluation.

Before we will start to supply this part to you, we would like you to ask us the formal version of this spec sheet.

We will issue the formal specification sheet for you. (Basically the contents is the same as this one.)

We would like you to put your signature on it to state your approval of the specification, and send it back to us.

It will be a kind of contract between you and us.

Seller: **Seiko Instruments Inc.**  
Micro-Energy Division

## History of Revision

No.	Details of Change	Issue Date
01	Initial Release for Standard specifications	April.6.2015

## Manufacturer information

Company name: **Seiko Instruments Inc.**  
Micro-Energy Division

Address: 45-1, Aza-Matsubara, Kami-ayashi, Aoba-ku, Sendai-shi, Miyagi,  
Japan, postal code : 989-3124

## Index

Contents	page
Cover page	1
History of Revision Manufacturer Information	2
Index	3
1. Application	4
2. Model	4
3. Chemical System and Structure	4
4. Nominal Specifications	4
5. Characteristics Electric characteristics Mechanical characteristics Reliability Parameter for Test and Measuring	5
6. Measuring Methods	7
7. Test Methods	8
8. Mounting Conditions	9
9. Indications(Markings)	9
10. Inspection	10
11. Package Specifications	10
12. In case of quality trouble	10
13. Operation of this Specification	10

## Appendix

Leakage Criteria

Construction of Battery

Battery drawing with tabs

Drawing of tray

Package specifications

Precautions for Your Safety

## 1. Application

This specification applies to the coin-type MS Lithium Rechargeable Battery, which manufactured by Seiko Instruments Inc. to the specified customer in cover page.

## 2. Model

Model described in cover

## 3. Chemical System and Structure

Refer to the document "The construction of battery" attached.

## 4. Nominal Specifications

		Model
No.	Characteristics	MS621T
4-1	Range of temperature in which it can function	From -30°C to 85°C
4-2	Recommended temperature range for use	From 0°C to 30°C
4-3	Recommended range of preservation temperature and humidity	From 10°C to 30°C 60%RH or less
4-4	Nominal voltage (V)	3.0
4-5	Charging voltage (V)	From 2.8 to (Max.)3.3
4-6	Recommended Charging voltage (V)	3.1
4-7	Maximum Charging Current (mA) At 3.1V in the battery voltage. At 0V in the battery voltage.	0.5 10
4-8	Nominal capacity(mAh): after charging from 3.1V to 2.0V	3.0
4-9	Remaining Capacity (mAh): At delivery	2.7
4-10	Standard Discharge Current (mA)	0.015
4-11	Maximum Discharge Current(mA) the half of nominal capacity can be taken out.	0.1
4-12	Nominal dimensions Diameter (mm) Height (mm)	6.8 2.1
4-13	Standard mass (g)	0.23
4-14	Applicable Safety Standard	UL1642 (UL File No.MH15628)

■ The "Perchlorate Contamination Prevention Act" in California does not apply to this product."

## 5. Characteristics

\* "Initial" means within one month after deliver.

\* Attached "Leakage Criteria" is used for the judgment of leakage.

### 5-1. Electric characteristics

No.	Characteristics	Model	Test Methods	Measuring Methods	
		MS621T			
1	Open Circuit Voltage(V) at delivery		7-1	6-4	
		maximum			3.4
		minimum			2.6
2	Open Circuit Voltage(V) after charge		7-1	6-2 1) 6-4	
		maximum			3.1
		Minimum			2.8
3	Initial Capacity(mAh)		7-2	6-2	
		24°C			2.55 or more
		-30°C			0.7 or more
		85°C			2.55 or more
4	Initial Internal impedance(ohm)		7-2	6-3	
		24°C			300 or less
		-20°C			1000 or less
		60°C			300 or less

### 5-2. Mechanical characteristics

No.	Characteristics	Model	Test Methods	Measuring Methods	
		MS621T			
1	Tab Pulling Strength(N): In the case of Battery with tabs.		-	6-8	
		-			Refer to Battery Drawing with tabs attached
2	External Appearance		-	6-9	
		Initial			No leakage There must not be foreign body adhesion (over level S2). There is no significant deformation, stain, stricken mark, rust and burr.
		After Tests			There is no significant leakage (over level C1), deformation, stain, stricken mark, rust and burr.
3	Free fall	Satisfy initial capacity and internal impedance. There is no significant leakage, deformation, stain, stricken mark, rust and burr, which effect battery performance.	7-8	6-2 6-3 6-9	
4	Vibration	Satisfy initial capacity and internal impedance. There is no significant leakage, deformation, stain, stricken mark, rust and burr, which effect battery performance.	7-9	6-2 6-3 6-9	

## 5-3. Reliability

No.	Characteristics	Model	Test Methods	Measuring Methods
		MS621T		
1	High Temperature Storage Characteristics		7-3	6-2
	Min. Capacity(mAh)	2.25		
2	Float Charge Characteristics		7-4	6-2 6-3
	Min. Capacity(mAh)	2.25		
	Max. Internal impedance (ohm)	500		
3	Over Discharge Characteristics		7-5	6-2
	Min. Capacity(mAh)	1.5		
4	Charge / Discharge Cycle Characteristics (Cycles)			6-2
	20% D.O.D.	500 cycles or more	7-6-1	
	100% D.O.D.	100 cycles or more	7-6-2	
5	Leakage Resistance	level S3 (*1) or less (There is no significant leakage which effect battery performance.)	7-7	6-9

## 5-4. Table of Parameter for Test and Measuring

No.	Characteristics	Model	Test Methods	Measuring Methods
		MS621T		
1	Capacity		-	6-2
	Vc(V)	3.1		
	Rp(kohm)	0.47		
	Tc(hrs)	96		
	Rd(kohm)	220		
	Voff(V)	2.0		
2	Float Charge Characteristics		7-4	
	Vc(V)	3.1		
	Rp(kohm)	0.47		
3	Over Discharge Characteristics		7-5	
	Rs(kohm)	22		
4	Charge / Discharge Cycle(20% D.O.D)		7-6-1	
	Vc(V)	3.1		
	Rp(kohm)	0.47		
	Tcs(hrs)	10		
	Rds(kohm)	22		
	Tds(hours)	4.5		
5	Charge / Discharge Cycle(100% D.O.D)		7-6-2	
	Vc(V)	3.1		
	Rp(kohm)	0.47		
	Tcd(hrs)	48		
	Rdd(kohm)	22		
	Tdd(hours)	23		

## 6. Measuring Methods

### 6-1. General Conditions

The measuring conditions are temperature of 24+/-2 °C, humidity of 65+/-20%Rh and within one month after delivering, if not specified.

### 6-2. Capacity

- 1) Charging: Apply specified voltage ( $V_c$ ) through the protective resistance ( $R_p$ ) for specified time ( $T_c$ ).
- 2) Discharging: Discharging with load resistance ( $R_d$ ) until the cell voltage reaches the cut off voltage ( $V_{off}$ ), the cell voltage ( $V_i$ ) and time ( $T_i$ ) should be measured at intervals within one hour.
- 3) Calculation: The capacity value is calculated by the expression below.

$$Capacity = \sum_i \left( \frac{(V_i + V_{i+1})}{2} \times \frac{1}{R_d} \times (T_{i+1} - T_i) \right)$$

- 4) General Circuit: The circuit, for charging and discharging, is shown as follows.

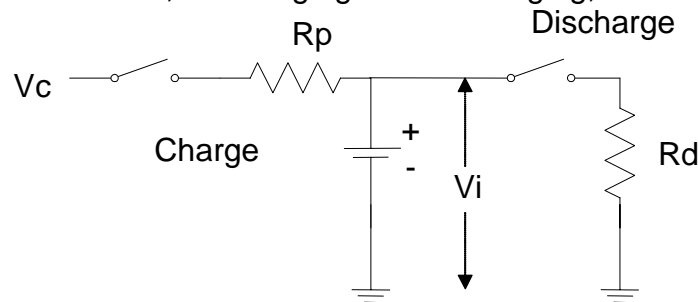

### 6-3. Internal Impedance

Measure by alternating current method using frequency of 1kHz.

### 6-4. Voltage

Use a direct current voltage meter, which has input impedance of 10Mohm or more and accuracy of +/-0.2% or less.

### 6-5. Current

Use an ammeter with accuracy of +/-0.2% or less.

### 6-6. Resistance

Resistance, which includes resistance of all external circuits, requires accuracy of 2.0% or less.

### 6-7. Size measurement

Use the size measurement instruments with accuracy of 0.01mm or 0.001mm if necessary.

### 6-8. Terminal pull strength: The direction of the pull is vertical.

Use a digital force gauge, which has accuracy of +/-1.0% or less.

### 6-9. Appearance

- |             |  |
|-------------|--|
| After Test  | : Microscope, which has magnification of 10 times. |
| At delivery | : Naked eye  |

## 7. Test Methods

### 7-1. General conditions

If not specified, the test conditions are temperature of  $24\pm 2$  °C, humidity of  $65\pm 20\%$ Rh and The test should be started within one month after delivering.

### 7-2. Temperature Characteristics Test

Measure electrical characteristics after exposing battery to each temperature atmosphere for 2 hours.

Temperature:  $-30\pm 2$  °C,  $+24\pm 2$  °C,  $+85\pm 2$  °C

### 7-3. High Temperature Storage

After Charging at voltage of  $V_c$  through protective resistance of  $R_p$  for  $T_c$  hours, store battery at temperature  $85\pm 2$  °C for 20days.

### 7-4. Float Charge Characteristics Test

Charge battery at voltage of  $V_c$  through protective resistance of  $R_p$  at temperature of  $85\pm 2$  °C for 20days.

### 7-5. Over Discharge Characteristics Test

Discharge battery by discharge resistance of  $R_s$  for 30 days.

### 7-6. Charge / Discharge Cycle Characteristics Test

#### 7-6-1. Shallow Discharge cycle characteristics (20% Depth of discharge)

Charge : Apply specified voltage ( $V_c$ ) through protective resistance ( $R_p$ ) for specified period ( $T_{cs}$ ).

Discharge : With load resistance ( $R_{ds}$ ) for specified period ( $T_{ds}$ ).

Life : Let the time of putting on measurement of 6-2 and becoming 50% of a initial capacity standard value be a life.

#### 7-6-2. Deep Discharge cycle characteristics (100% Depth of discharge)

Charge : Apply specified voltage ( $V_c$ ) through protective resistance ( $R_p$ ) for specified period ( $T_{cd}$ ).

Discharge : With load resistance ( $R_{dd}$ ), for specified time ( $T_{dd}$ ) or until the cell voltage reaches 2.0V.

Life : Let the time of putting on measurement of 6-2 and becoming 50% of a initial capacity standard value be a life.

### 7-7. Leakage Resistance (Thermal Shock Test: Air to Air)

Hold battery at  $-10\pm 2$  °C for 1 hour then hold it at  $85\pm 2$  °C for 1 hour.

Repeat 100 cycles between above conditions. (Chamber) Not humidity controlled.

### 7-8. Free Fall Test

Drop the battery ten times in an arbitrary direction on the board of the oak of 3cm in thickness from the height of 75cm. The tabs of battery should be cut before test.

### 7-9. Vibration Test

Vibrate the battery in the direction of 3(x, y, z) for 30 minutes by 1000 cycles per minute with an amplitude of 2mm. The tabs of battery should be cut before test.



## 8. Mounting Conditions

### 8-1. For soldering iron

Use the conditions as follows

Model	
MS614T	
Temperature	350 °C or less
Soldering time	Within five seconds

Within above conditions, do not heat battery over 90°C.

Do not solder directly to the battery.

### 8-2. Dip soldering

Not applicable

### 8-3. Reflow soldering

Not applicable

## 9. Indications (Markings)

### 9-1. Dies

Following items are indicated on battery.

Below items can be omitted except item (2).

(1) Model code

(2) Cathode polarity (+)

(3) Manufacturer's name or monogram

(4) Country of origin

### 9-2. Date of Manufacturing

Date of Manufacturing is marked on the positive tab or the battery (if possible) and label of each package as.

(Example)

61\*\*...manufactured in January 2016

5Y\*\*...manufactured in November 2015

60\*\*...manufactured in October 2016

Abbreviation of month : Jan. (1), Feb. (2).... Sep. (9), Oct. (0), Nov. (Y), Dec. (Z)

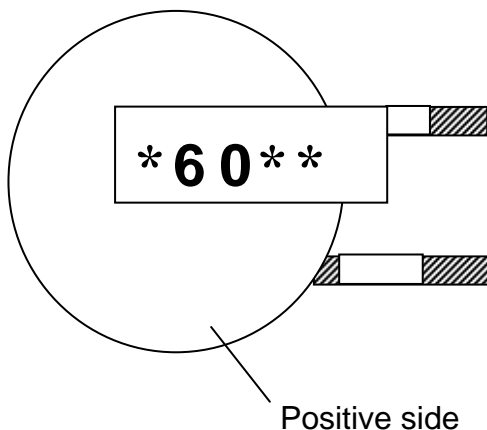

\* is identification of product.

\* \* is our own number, might be omitted.

Method of marking of manufacturing date is laser type.

## 10. Inspection

The customer should do incoming inspection within 30 days from receiving day. If defective products are found out at incoming inspection, the customer immediately should notify to Seiko Instruments Inc. in writing with the defective products for replacement request. When there was no contact from you within 30 days, we shall judge that those were accepted.

## 11. Package Specifications

Examples of the tray for wrapping, wrapping specification, and packing specification are shown in the following as our standard.

### 11-1. The tray for wrapping

Refer to "Drawing of tray".

The positive electrode can of the Battery stored in the tray is upward.

### 11-2. Wrapping and packing

Refer to "Package specifications" .

## 12. In case of quality trouble

The warranties set forth herein are the only warranties on the products.

The liabilities of Seiko Instruments Inc. in connection with the products under these specifications are expressly limited to the replacement of defective products.

## 13. Operation of this Specification

### 13-1. Agreement

Before these specifications being revised, the agreement, of the customer, seller and manufacturer, is required.

### 13-2. Negotiation

If some accident not specified on these specifications occurs, the customer, seller and manufacturer must negotiate in order to solve the problem faithfully.

## Leakage Criteria

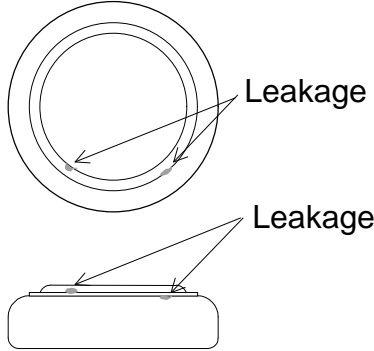
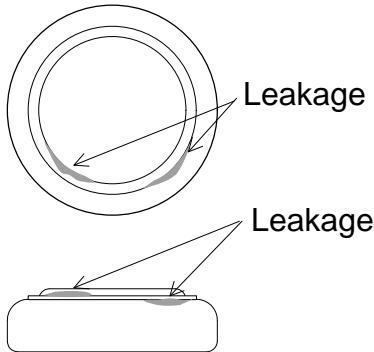
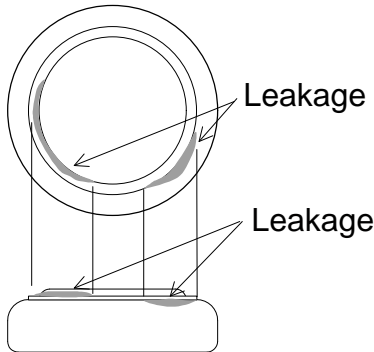
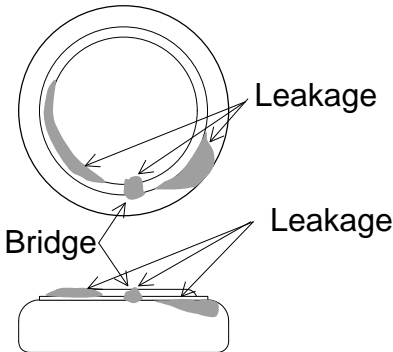
Grade	Criteria	
	Diagram	Definition
S1		<p>The leakage can not be seen by naked eyes, but can be seen by microscope, which have magnification of 10 to 15.</p>
S2		<p>The leakage can be seen by naked eyes. The area of leakage is within half of the round and reaching to neither the flat area of the negative can nor the straight area of the positive can. The leakage is not bridged between the negative can and the positive can.</p>
S3		<p>The area of leakage is from half to all of the round and reaching to neither the flat area of the negative can nor the straight area of the positive can. The leakage is not bridged between the negative can and the positive can.</p>
C1		<p>The area of leakage is reaching to either the flat area of the negative can or the straight area of the positive can. The leakage is bridged between the negative can and the positive can.</p>

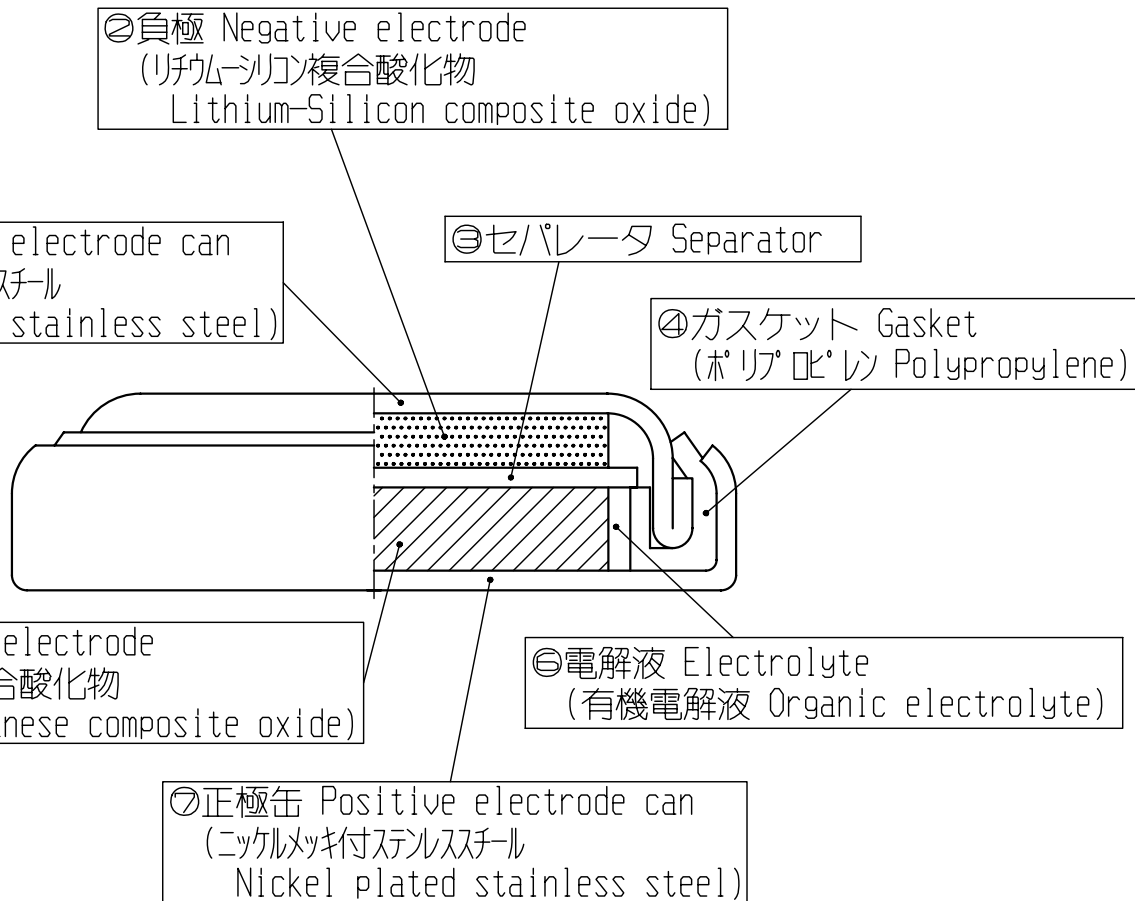

			File No. 文件番号	30460000-MST00-1
			Material 材料	
			Process 処理	
			Date 日付	Feb. 20, 2014
E14A-003	Feb. 20, 2014	設定	Name 名称	Construction of battery 電池構成図
History 履歴	Date 日付	Reason 理由	Cal. No. 製品番号	MS***T
Approved 承認	Checked 検査	Drawn 製図	Scale 尺度	
鈴木		三浦	Unit 単位	
			Rev. 改訂	1
			Drw. No. 図面番号	3046 MST00

(NOTES) 1. TAB pulling strength : Over 9.8N(1.0kgf)

(注) 1. 端子引張強度 : 9.8N(1.0kgf) 以上

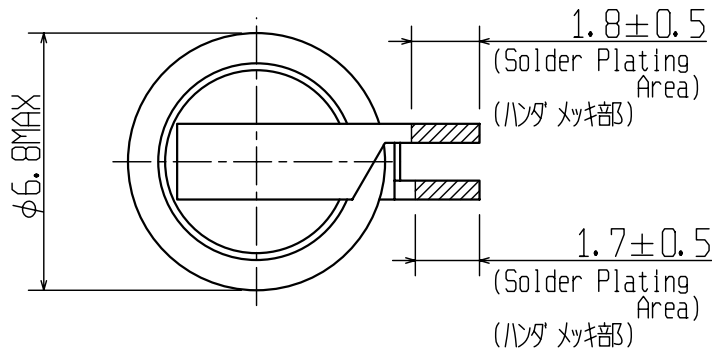
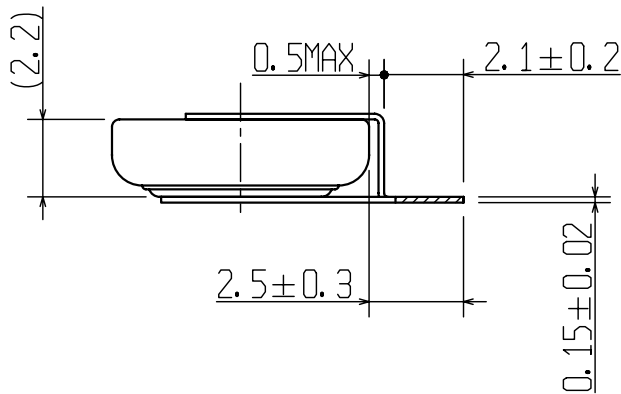
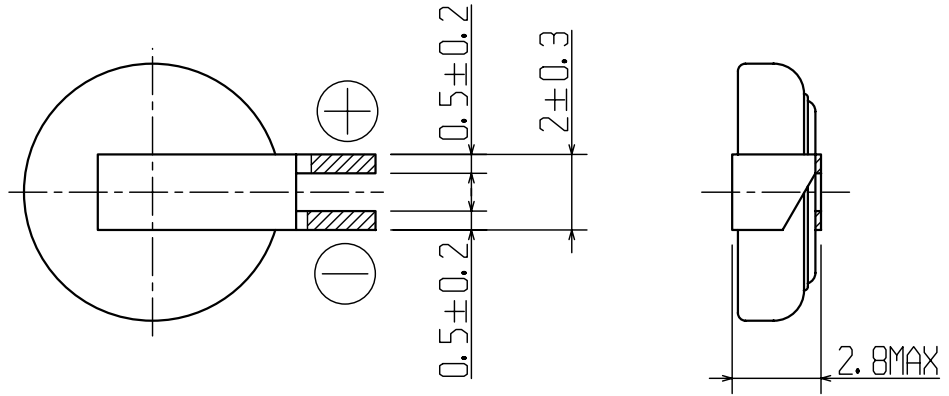

Tolerances of linear dimensions 長さ寸法公差		
Dimension 寸法		Tolerance 公差
0 - 3		±0.20
3 - 6		±0.20
6 - 30		±0.50
Tolerances of angular dimensions 角度寸法公差		
±2°		

				File No. ファイル番号	3046T650-FL11E-1
				Material 材料	TAB: SUS304-Ni·P H/2
				Process 処理	: Solder plating ハンダメッキ 2~4μm (Sn 100%)
				Date 日付	Jan. 13.' 15
E15A-002	Jan. 13.' 15	設定		Name 名称	Battery drawing with tabs 端子付電池図面
History 履歴	Date 日付	Reason 理由			
Approved 承認	Checked 検査	Drawn 製図	Scale 尺度	5:1	Cal. No. 製品番号
鈴木		三浦	Unit 単位	1=1mm	MS621T FL11E
			Rev. 改訂	1	

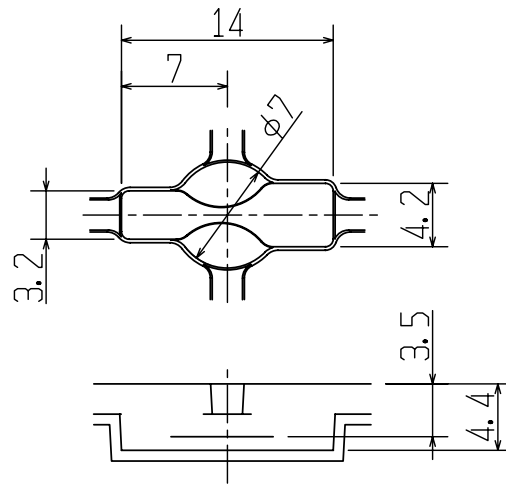
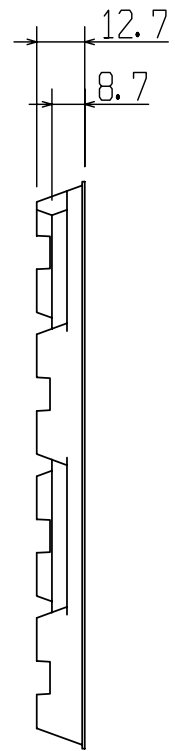
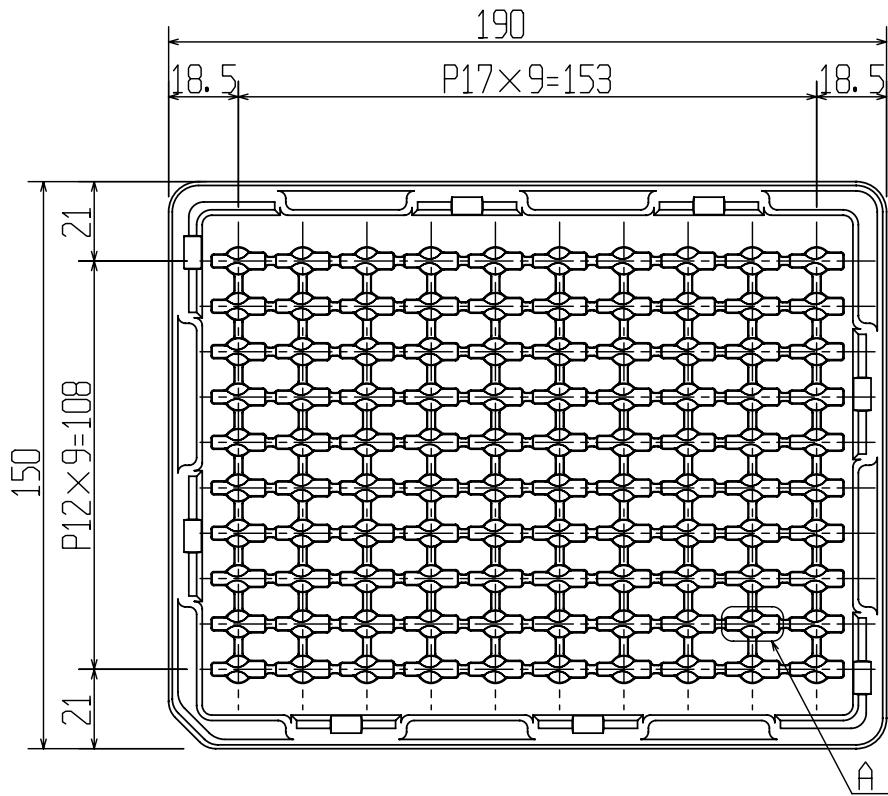

Detail A (2:1)  
詳細 A (2:1)

Tolerances of linear dimensions 長さ寸法公差	
Dimension 寸法	Tolerance 公差
$L \leq 10$	$\pm 0.50$
$10 < L < 60$	$\pm 0.80$
$60 < L < 100$	$\pm 1.00$
$100 \leq L$	$\pm 1.50$
Tolerances of angular dimensions 角度寸法公差	
$\pm 2^\circ$	

				File No. 文件番号	31760000-II000A1
				Material 材料	Polystyren ポリスチレン
				Process 処理	
				Date 日付	Mar. 25.'05
E05A-010	Mar. 25.'05	設定		Name 名称	Drawing of tray
History 履歴	Date 日付	Reason 理由			トレー図
Approved 承認	Checked 検査	Drawn 製図	Scale 尺度	Cal. No. 製品番号	II Tray
山田	冨塚	尾形	Unit 単位	1=1mm	II トレー
			Rev. 改訂	1	

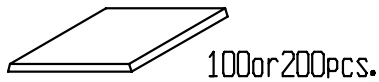

100又は200個入り トレイ  
100 or 200pcs. In a tray

ラベル: 製品名, Lot No, 数量, 備考  
Label: Model, lot number, quantity, remarks

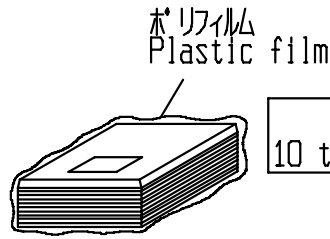
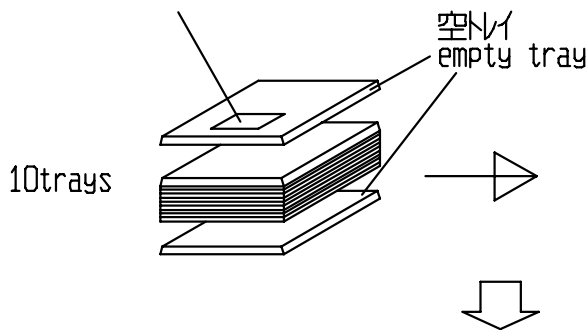

10 トレイ ポリパック  
10 trays in plastic film pack

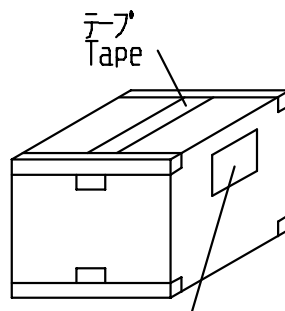
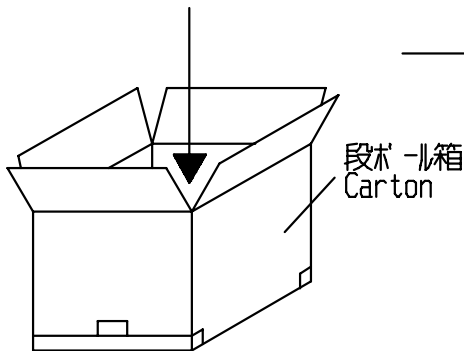

最大4000個入りカートン  
Max 4000pcs. in carton

カートンラベル: 行き先, 原産国, カarton No., 航空貨物専用ラベル  
注意表示 (リチウム電池) 等  
Carton label: Destination, country of origin,  
carton number., CARGO AIRCRAFT ONLY LABEL  
! CAUTION (Lithium metal battery) etc.

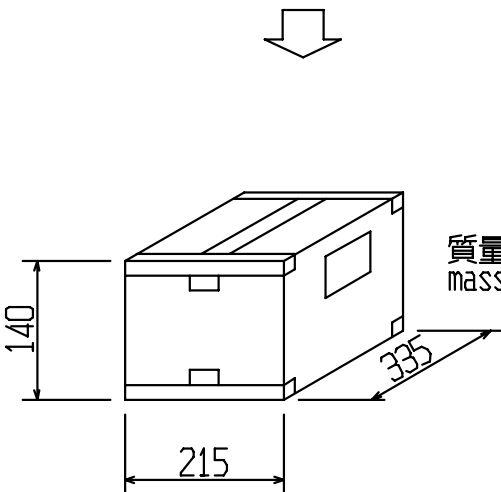

質量: 最大2.5kg  
mass: MAX 2.5kg



梱包外観  
Package appearance

上記、梱包形態は標準的なもので、納入時の数量により異なります。  
The above packaging specifications are standard.  
These specifications vary with the quantity to be supplied.

E15B-003	Feb. 02, 2015	CAOラベル, CAUTIONラベルの追記			File No. ラベル番号	31760A21-00000-4
E12B-001	Jan. 10, 2012	仕向け先表記削除			Date 日付	03. Dec. '08
E10B-003	Jan. 21, 2010	テープ表記変更			Name 名称	梱包仕様 Package specifications
E08A-042	03. Dec. '08	設定			Cal. No. 製品番号	A21
History 履歴	Date 日付	Reason 理由			Draw. No. 図面番号	3176 0A21
Approved 承認	Checked 検査	Drawn 製図	Scale 尺度			
鈴木	/	尾形	Unit 単位	1=1mm		
			Rev. 改訂	4		

# Precautions for Your Safety

**SII Lithium rechargeable batteries (MS, ML, HB, TS) contain flammable organic solvents. For your safety, please follow following prohibitions.**

## **WARNING!**

- 1. Do not charge by high current or high voltage.**  
Doing so may generate gas inside the battery, resulting swelling, catching fire, and heat generation or bursting.
- 2. Do not heat, disassemble nor dispose of in fire**  
Doing so damages the insulation materials and may cause catching fire, heat generation, leakage or bursting.
- 3. Do not solder directly to the battery**  
If soldering is performed directly to the battery, the battery is heated up, consequently cause leakage, explosion or fire due to overheating from internal short-circuiting.
- 4. Do not short.**  
If the (+) and (-) come into contact with metal materials, short-circuiting occurs. As a result, catching fire, heat generation, leakage or bursting.
- 5. Keep batteries out of children's reach.**  
If leaked liquid is ingested or a battery is swallowed, consult a physician immediately.
- 6. Do not reverse placement of (+) and (-)**  
If the (+) and (-) side of the battery is reverse inserted, it may cause a short-circuiting or over discharge of the battery on some equipment and it may induce overheating, explosion or fire.
- 7. Do not discharge by force**

- If the battery is discharged by direct connection to an external power supply etc., voltage of the battery will decline lower than 0 volts (electrical reversal) and will cause the battery case to expand, overheat, leak, explode or burn.
- 8. In case of leakage or a strange-smell; keep away from fire to prevent ignition of any leaked electrolyte.**
  - 9. In case of disposal, insulate between (+) and (-) of battery by an insulating**  
Jumbling batteries or with other metal materials cause short-circuiting. As a result, catching fire, heat generation, leakage or bursting.

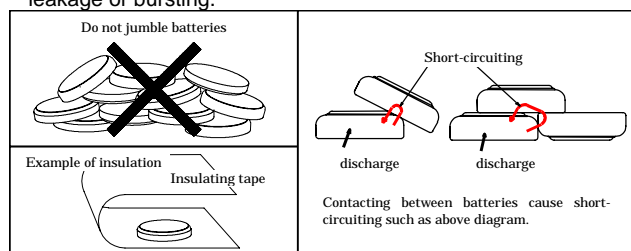

## **CAUTION!**

- 1. If leaked liquids gets in the eyes, wash them with clean water and consult a physician immediately.**
- 2. Do not use new and used batteries together. Do not use different types of batteries together.**  
It may cause catching fire, heat generation, leakage or bursting.
- 3. If you connect two or more batteries in series or parallel, please consult us in advance.**  
It may cause bursting or catching fire due to unbalanced load or voltage.
- 4. Do not use nor leave the batteries in direct sunlight nor in**

- high-temperature areas.**  
It may cause catching fire, heat generation, leakage or bursting.
- 5. Do not apply strong pressure to the batteries nor handle roughly.**  
It may cause catching fire, heat generation, leakage or bursting.
  - 6. Avoid contact with water.**  
It may cause heat generation.
  - 7. Keep batteries away from direct sunlight, high temperature and humidity.**  
It may cause heat generation.

## For prevention the performance of battery

- Battery with tabs or battery on PCB may short circuit on the mat for ESD. As a result the voltage of cell drops down.
- 2. Pay attention to soldering by tips**  
Do no touch the battery by solder chips, in case of soldering another components after equipping battery.  
In basically, keep any high temperature process away from battery.

- 3. Pay attention to material of jig for pick and place**  
Use nonconductive material of jig for pick and place of batteries, for short-circuit protect. If short circuit of battery is occurred, the voltage of battery drops down quickly but raise gradually.
- 4. Pay attention to washing and drying**  
Some detergent or high temperature drying cause deteriorates of battery. If wash batteries, consult us.

## International Transportation and Disposal

### International Air / Marine / Ground Transportation

Based on the United Nations (UN) regulations, organizations such as IATA, ICAO, IMO & DOT have imposed transportation regulations pertaining to Lithium batteries.

In the case of air transportation, Seiko Instruments' Lithium rechargeable batteries can be transported as "Non-dangerous Goods", as long as they meet the following requirements.

- <Lithium content>** Lithium-equivalent content must be less than 1.0 g.
- <Safety Certification>** Each battery must meet all test requirements stated in the UN Manual of Tests and Criteria, Part 3, sub-section 38.3
- <Packaging>** Each battery must be packed separately, in order to prevent short-circuiting. Firm packaging is also required.
- <Labeling>** Each carton box must have a "Caution" label attached.  
The label must indicate; <1> emergency telephone number, <2> its contents as Lithium batteries, and <3> special procedures in the event of package damage.
- <Not Restricted Declaration>** Each shipment requires a document indicating; <1> emergency telephone number, <2> its contents as Lithium batteries, and <3> special procedures in the event of package damage.
- <Package Drop Test>** Each package must pass a 1.2m drop test without damaging contained batteries.

(g) **<Weight Limit>** Each package must not exceed 2.5 kg gross mass, except in the case of batteries already installed in a completed device.

(h) **<Transporting to U.S.A.>** In the event of transporting Lithium batteries to the U.S., 24 hour emergency contact information must be indicated on the required documents.

### **<Package contains Lithium battery built into product >**

If the number of cells per package is greater than five, both a "Not Restricted declaration" and appropriate labeling is required from January 1st, 2009.

### **<Package contains both Lithium battery and product with built-in Lithium battery >**

"Not Restricted declaration" and labeling are required from January 1st, 2009. Number of Lithium batteries per package limited to typical quantity to operate a product in a package, plus 2 additional battery units.

For questions regarding marine/ground transportation, please contact us.

For further information, please contact us.

### **Disposal**

Recent environmental protection concerns have increased globally and waste and recycling are regulated in the world. The current regulations differ in each country, state and local municipality. Please consult local regulations and authorities for recommended disposal of batteries. If you are in question of application or safety of our batteries, please consult your local authorities.