

Circuits from the Lab®
Reference Designs

Circuits from the Lab® reference designs are engineered and tested for quick and easy system integration to help solve today's analog, mixed-signal, and RF design challenges. For more information and/or support, visit www.analog.com/CN0255.

Devices Connected/Referenced

AD7988-1	16-Bit, 100 kSPS PulSAR ADC
ADA4841-1	Low Power, Low Noise Amplifier
AD8032	Dual-Channel, Rail-to-Rail Buffer Amplifier
AD8031	Single-Channel, Rail-to-Rail I/O Op Amp
ADR4525	2.5 V Low Noise Voltage Reference

16-Bit, 100 kSPS, Single-Supply, Low Power Data Acquisition System

EVALUATION AND DESIGN SUPPORT

Evaluation Boards

CN-0255 Circuit Evaluation Board ([EVAL-CN0255-SDPZ](#))

System Demonstration Platform ([EVAL-SDP-CB1Z](#))

Design and Integration Files

[Schematics](#), [Layout Files](#), [Bill of Materials](#)

CIRCUIT FUNCTION AND BENEFITS

In most systems, there are tradeoffs between performance and low power. The focus of this circuit design is to explore a few of these tradeoffs and still achieve low power (8 mW typical) and high performance in a 16-bit, 100 kSPS data acquisition system.

This circuit uses the [AD7988-1](#), a low power (350 μ A) PulSAR® analog-to-digital converter (ADC), driven directly from the [ADA4841-1](#) high performance, low voltage, low power op amp. This amplifier was chosen for its excellent dynamic performance and its ability to operate with a single-supply voltage and to provide a rail-to-rail output. In addition, the input common-mode voltage range includes the negative rail.

The [AD7988-1](#) ADC requires an external voltage reference between 2.4 V and 5.1 V. In this application, the voltage reference chosen was the [ADR4525](#) precision 2.5 V reference.

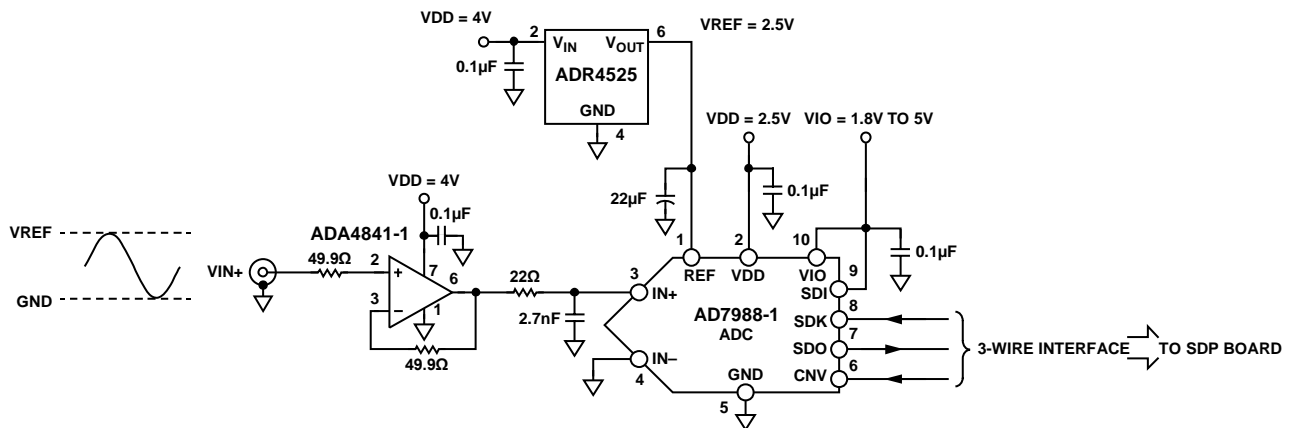

Figure 1. Basic Single-Ended, Low Voltage, Low Power, 16-Bit, 100 kSPS ADC Solution

Rev. A

Circuits from the Lab® reference designs from Analog Devices have been designed and built by Analog Devices engineers. Standard engineering practices have been employed in the design and construction of each circuit, and their function and performance have been tested and verified in a lab environment at room temperature. However, you are solely responsible for testing the circuit and determining its suitability and applicability for your use and application. Accordingly, in no event shall Analog Devices be liable for direct, indirect, special, incidental, consequential or punitive damages due to any cause whatsoever connected to the use of any Circuits from the Lab circuits. (Continued on last page)

CIRCUIT DESCRIPTION

The heart of this circuit is the [AD7988-1](#), a 16-bit, 100 kSPS successive approximation, ADC that operates from a single VDD power supply. It contains a low power, high speed, 16-bit sampling ADC and a versatile serial port interface (SPI). On the CNV rising edge, it samples an analog input, IN+, between 0 V to REF with respect to the ground sense pin, IN-. The reference voltage, REF, is applied externally and can be set independent of the supply voltage, VDD.

For the experiments carried out for this circuit note, the [AD7988-1](#) evaluation board was interfaced to the System Demonstration Platform (SDP), [EVAL-SDP-CB1Z](#), where the ADC SPI-compatible serial interface was connected to the DSP SPORT interface. The ADCs SPI interface features the ability to daisy-chain several ADCs on a single 3-wire bus. It is compatible with 1.8 V, 2.5 V, 3 V, or 5 V logic, using the separate VIO supply pin.

The [AD7988-1](#) is housed in a 10-lead MSOP or a 10-lead QFN (LFCSP). This board uses the MSOP package for convenience.

The ADC input is buffered and driven from the [ADA4841-1](#), a unity-gain stable, low noise and low distortion, rail-to-rail output amplifier that operates with a quiescent current of 1.1 mA typically. This amplifier offers a low wideband voltage noise of 2.1 nV/ $\sqrt{\text{Hz}}$ and 1.4 pA/ $\sqrt{\text{Hz}}$ current noise, along with excellent spurious-free dynamic range (SFDR) of -105 dBc at 100 kHz. To maintain a low noise environment at lower frequencies, the amplifiers have low 1/f noise of 7 nV/ $\sqrt{\text{Hz}}$ and 13 pA/ $\sqrt{\text{Hz}}$ at 10 Hz.

A key feature of the [ADA4841-1](#), making it ideally suited to single-supply applications, is that in this application it can operate from a single rail, with the negative rail tied to ground. The amplifier output can swing to within 50 mV of the ground level, which is acceptable for this application. Note that the input common-mode

voltage range extends from the negative supply rail to within 1 V of the positive rail. This necessitates 1 V headroom to accommodate the signal range of interest (0 V to 2.5 V); therefore, in this circuit, a 4 V rail was used. The [ADA4841-1](#) is available in a 6-lead SOT-23 or an 8-lead SOIC.

The 2.5 V voltage reference used in this application is the [ADR4525](#) from the [ADR45xx](#) series of references, providing high precision, low power, low noise, and featuring $\pm 0.01\%$ initial accuracy, excellent temperature stability, and low output noise. System performance is improved by the [ADR4525](#) low thermally induced output voltage hysteresis and low long-term output voltage drift. A maximum operating current of 700 μA and a low dropout voltage of 500 mV maximum make the device optimum for use in portable equipment.

Each of the three products used in the circuit are rated for operation over the full industrial temperature range, -40°C to +125°C.

Performance Expectations

Because power is key in this application, an analysis of each of the component's contribution is necessary to ensure appropriate selection among the many available products. The first step was reviewing the different supply currents for the three devices selected.

The typical calculated and measured supply currents are shown in Table 1 for each of the contributing components. The VIO supply from the digital interface of the ADC is not included here because it is negligible. The measured currents compare favorably with the calculated values; the small discrepancy can be attributed to the passive components and slight variations in supply currents from that of the typical data sheet specifications.

Table 1. Calculated and Measured Supply Current Contributions

Load	Description	Calculated			Measured		
		Supply Current	Supply Voltage	Power	Supply Current	Supply Voltage	Power
ADC	AD7988-1	150 μA	2.5 V	375 μW	148 μA	2.5 V	370 μW
Driver	ADA4841-1	1.1 mA	4 V	4.4 mW	1.95 mA	4 V	7.8 mW
Reference	ADR4525	700 μA	4 V	2.8 mW			
Reference load	ADC ref current	60 μA	4 V	240 μW			
Total				7.81 mW			8.17 mW

When using low value reference voltages, some degradation is expected in the ac performance of the AD7988-1 ADC. This performance degradation is shown in Figure 2, where the signal-to-noise ratio (SNR), signal-to-noise-and-distortion (SINAD), and effective number of bits (ENOB) are shown as a function of the reference voltage. Note that for a 2.5 V reference, a SNR performance of approximately 86 dB to 87 dB is expected.

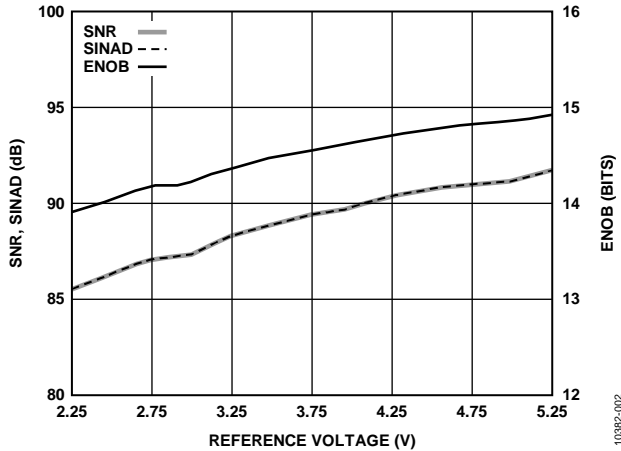

Figure 2. SNR, SINAD, and ENOB vs. Reference Voltage for the AD7988-1 ADC

Measurement results for the circuit are shown in Figure 3. The SNR performance of 86.17 dB is comparable to that expected with the 2.5 V reference voltage, as previously shown in Figure 2.

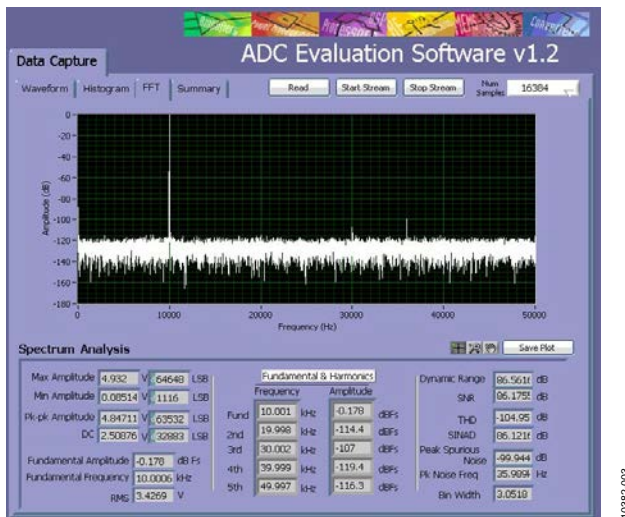

Figure 3. AC Performance with 100 kSPS Sampling Rate Measured with 10 kHz Input Tone, SNR = 86.17 dB

COMMON VARIATIONS

Other pin-compatible, 16-bit ADCs in the PulSAR® family are available at higher sampling rates: AD7988-5 (500 kSPS), AD7980 (1 MSPS), and AD7983 (1.33 MSPS). Note that the higher sample rates require more power. Alternatively, if higher resolution is required, suitable pin-compatible devices are the AD7691 (18-bit, 250 kSPS), AD7690 (18-bit, 400 kSPS), AD7982 (18-bit, 1 MSPS differential input), and the AD7984 (18-bit, 1.33 MSPS).

For higher input voltage ranges, choose a higher voltage reference and higher voltage supply rails for both the reference and the ADC driver.

Dynamic performance is shown in Figure 4 for the AD7988-5 (16-bit, 500 kSPS) ADC under similar conditions; however, with a sampling rate of 500 kSPS. The SNR is equal to 86.37dB.

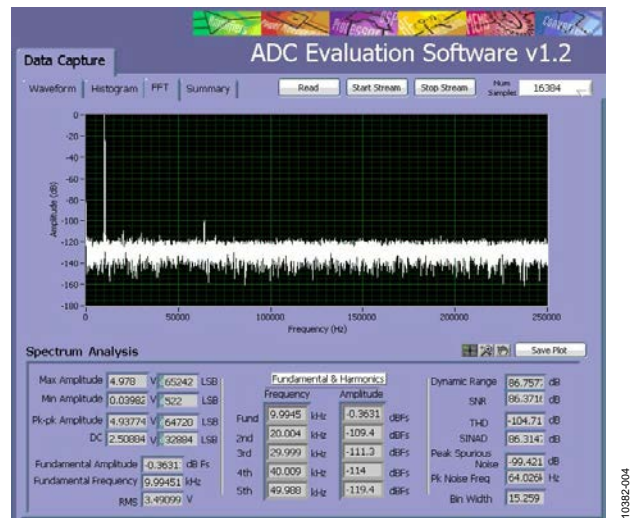

Figure 4. AC Performance with 500 kSPS Sampling Rate Measured with 10 kHz Input Tone Using the 500 kSPS AD7988-5 ADC, SNR = 86.37 dB

Adding an Input Common-Mode Voltage Bias Amplifier

In ac-coupled applications, the input signal must be biased so that it is centered within the ADC input range (0 V to 2.5 V for a 2.5 V reference). The circuit shown in Figure 5 addresses this common-mode signal requirement.

A wide range of amplifiers can be used for buffering purposes in this application. The AD8031 is a single-supply voltage feedback amplifier that features high speed performance with 80 MHz of small signal bandwidth, 30 V/μs slew rate, and 125 ns

settling time. This amplifier is unity-gain stable with a capacitive load and consumes less than 2.5 mW of power from a single 3.3 V supply. The AD8031 is available in a 5-lead SOT-23, an 8-lead SOIC, an 8-lead PDIP, and an 8-lead MSOP. In this circuit, the AD8031 is used to buffer the 2.5 V voltage reference to a voltage divider that provides the required 1.25 V common-mode voltage to the input of the ADA4841-1. The additional power used by the buffer is shown in Table 2.

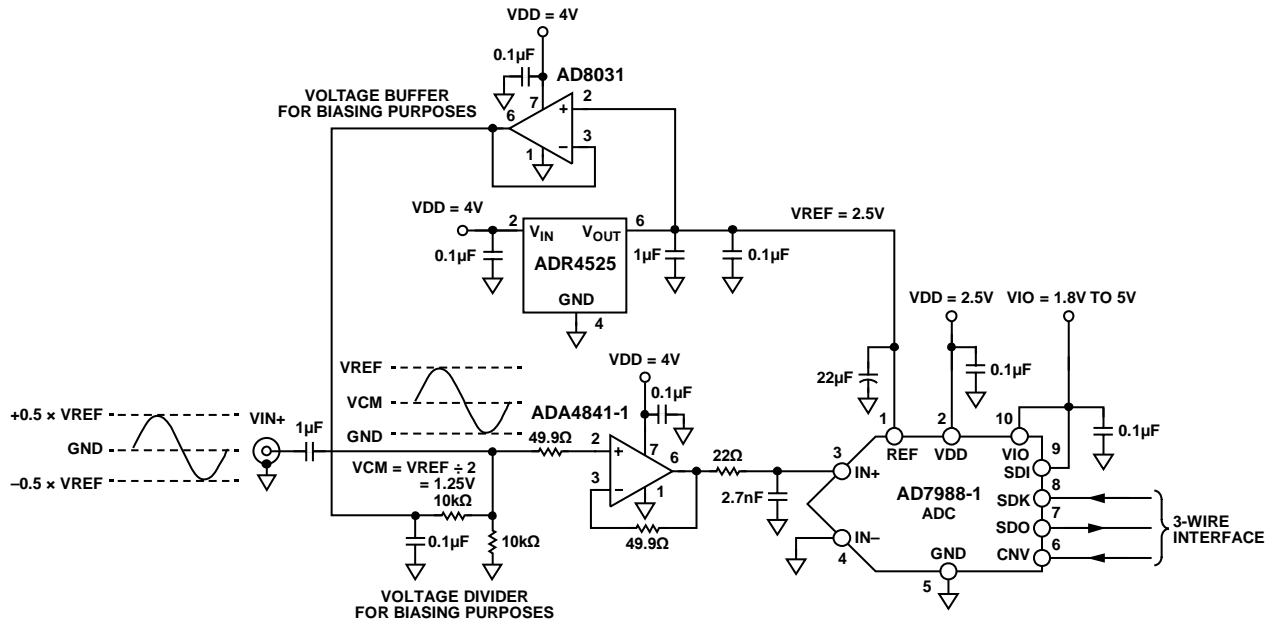

Figure 5. Enhanced Circuit Including a Common-Mode Buffer Used to Center the Input Voltage Range in an AC-Coupled Application

Table 2. Calculated Supply Current Contributions including VCM Buffer (AD8031)

Load	Description	Supply Current	Supply Voltage	Power
ADC	AD7988-1	150 μA	2.5 V	375 μW
Driver	ADA4841-1	1.1 mA	4 V	4.4 mW
Reference	ADR4525	600 μA	4 V	2.4 mW
VCM Buffer	AD8031	750 μA	4 V	3 mW
Total				10.17 mW

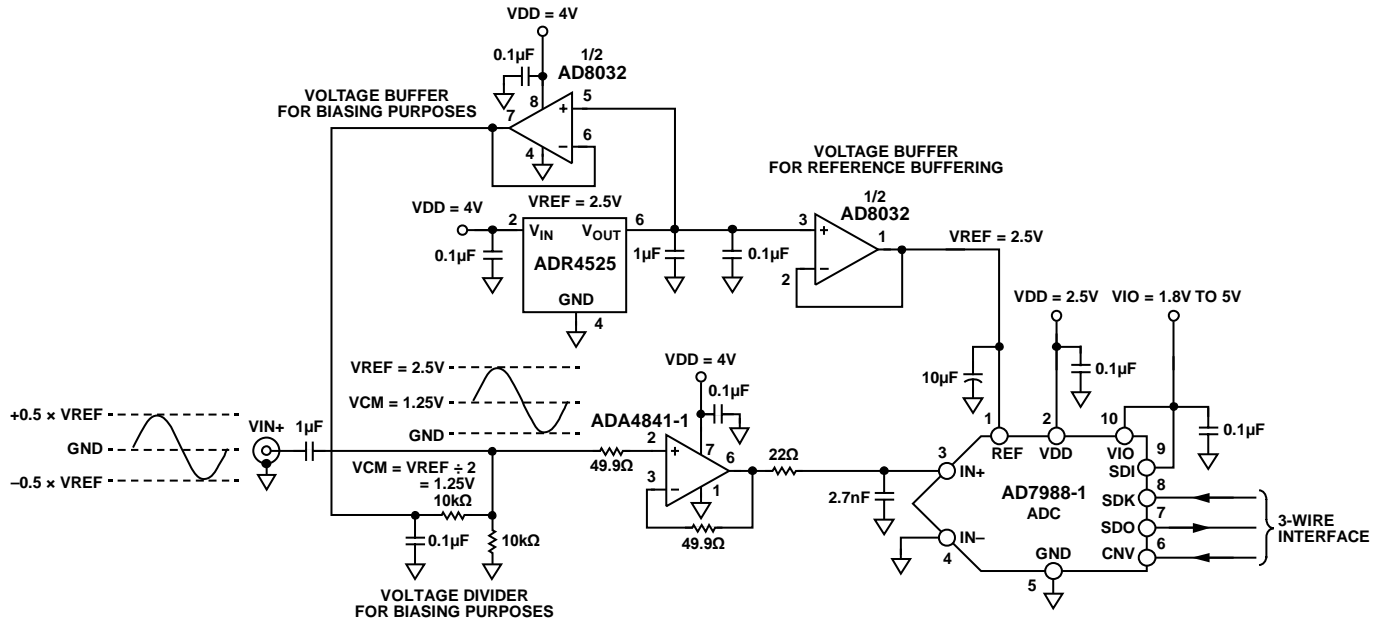

Figure 6. Enhanced Circuit Including Common-Mode and Reference Buffer

Adding a Reference Voltage Buffer

In applications where the voltage reference is shared between the different circuits, it may be necessary to buffer the reference voltage to ensure optimal performance. In this instance, using the AD8032 (a dual version of the AD8031) works quite nicely, as shown in Figure 6. Where the ADC reference input is buffered, the decoupling value can be reduced to a 10 μF ceramic chip capacitor located as close to the device as possible.

Figure 7 and Figure 8 show the performance for both the AD7988-1 and the AD7988-5, respectively, when using the AD8032 amplifier to create the VCM voltage level and to buffer the reference voltage, as is shown in Figure 6. This is the circuit implemented on the EVAL-CN0255-SDPZ board.

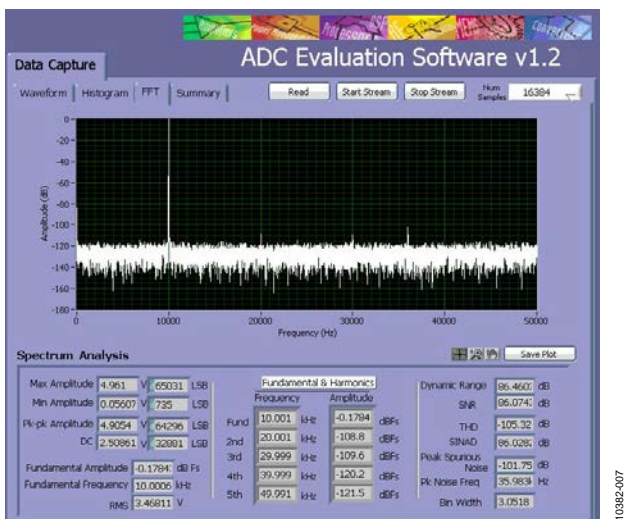

Figure 7. AC Performance Measured with 10 kHz Input Tone, AD7988-1 Sampling at 100 kSPS

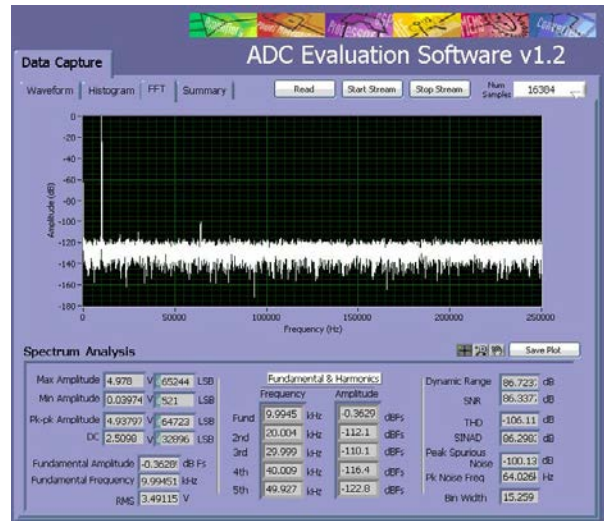

Figure 8. AC Performance Measured with 10 kHz Input Tone for Similar Configuration Using 500 kSPS, AD7988-5

CIRCUIT EVALUATION AND TEST

Equipment Needed (Equivalents Can Be Substituted)

- [EVAL-CN0255-SDPZ](#)
- System Demonstration Board ([EVAL-SDP-CB1Z](#))
- Function generator/signal source, such as Audio Precision SYS-2522 used in these tests.
- Power supply, 2.5 V and 4 V
- PC with USB port, USB cable, and installed 10-lead PulsAR software

Setup and Test

The block diagram of the ac performance measurement setup is shown in Figure 9. Connect the 2.5 V and 4 V power supply to the evaluation board power terminal.

To measure the frequency response, connect the equipment as shown in Figure 9. Set the Audio Precision SYS-2522 signal generator for a 10 kHz frequency and a 2.5 V p-p sine wave with a 1.25 V dc offset. Record the data using the evaluation board software.

The software analysis is part of the evaluation board software that allows the user to capture and analyze ac and dc performance.

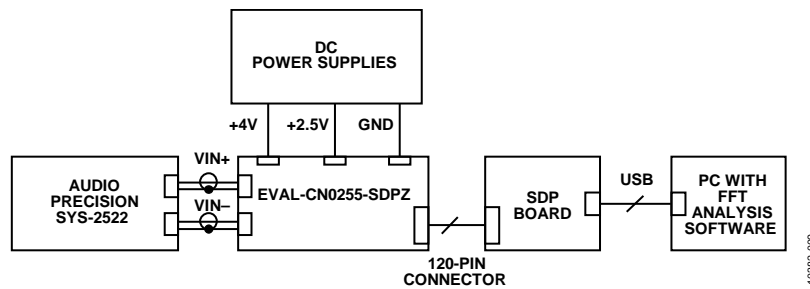

Figure 9. Circuit Test Setup for Measuring AC Performance

10892-009

LEARN MORE

CN0255 Design Support Package:

<http://www.analog.com/CN0255-DesignSupport>

System Demonstration Platform (SDP) website

MT-021 Tutorial, *Successive Approximation ADCs*, Analog Devices

Voltage Reference Selection and Evaluation Wizard, Analog Devices

MT-031 Tutorial, *Grounding Data Converters and Solving the Mystery of "AGND" and "DGND,"* Analog Devices.

MT-101 Tutorial, *Decoupling Techniques*, Analog Devices.

Data Sheets and Evaluation Boards

CN-0255 Circuit Evaluation Board (EVAL-CN0235-SDPZ)

System Demonstration Platform (EVAL-SDP-CB1Z)

AD7988-1 Data Sheet

AD7988-5 Data Sheet

ADR4525 Data Sheet

AD8031 Data Sheet

AD8032 Data Sheet

ADA4841-1 Data Sheet

REVISION HISTORY

12/13—Rev. 0 to Rev. A

Changes to Title..... 1

4/12—Revision 0: Initial Version

(Continued from first page) Circuits from the Lab reference designs are intended only for use with Analog Devices products and are the intellectual property of Analog Devices or its licensors. While you may use the Circuits from the Lab reference designs in the design of your product, no other license is granted by implication or otherwise under any patents or other intellectual property by application or use of the Circuits from the Lab reference designs. Information furnished by Analog Devices is believed to be accurate and reliable. However, Circuits from the Lab reference designs are supplied "as is" and without warranties of any kind, express, implied, or statutory including, but not limited to, any implied warranty of merchantability, noninfringement or fitness for a particular purpose and no responsibility is assumed by Analog Devices for their use, nor for any infringements of patents or other rights of third parties that may result from their use. Analog Devices reserves the right to change any Circuits from the Lab reference designs at any time without notice but is under no obligation to do so.

©2012–2013 Analog Devices, Inc. All rights reserved. Trademarks and registered trademarks are the property of their respective owners.
CN10382-0-12/13(A)

