

THIS DRAWING IS A CONTROLLED DOCUMENT FOR SOURIAU USA, INC. IT IS SUBJECT TO CHANGE WITHOUT NOTIFICATION. CONTACT THE DOCUMENT CONTROL CENTER FOR THE LATEST REVISION.

DWG. NO. **JBXPC1C**

4

3

2

1

ELECTRICAL:
 EMI SHIELDING : SHIELDED FOR THE RANGE 55dB UP TO 100MHZ
 INSULATION RESISTANCE : >500MΩ PER ANSI-EIA-364-D METHOD 21
 MAX. CURRENT RATING : SEE INSULATOR DRAWING
 CONNECTOR TESTING VOLTAGE : SEE INSULATOR DRAWING
 CONNECTOR WORKING VOLTAGE : SEE INSULATOR DRAWING

PHYSICAL:
 MAXIMUM WIRE SIZE USED : SEE INSULATOR DRAWING
 CABLE DIAMETER WITH PLASTIC COLLET SET SUPPLIED: Ø2mm MIN. TO Ø7.5mm MAX.

ENVIRONMENTAL:
 ENDURANCE: 1000 CYCLES AS PER MIL-STD 1344A, METHOD 2016.1
 SHOCK: 50 g , DURATION 6 ms; AS PER MIL-STD 1344A, METHOD 2004.1
 VIBRATIONS: 10 TO 2000Hz g = 15g. AS PER MIL-STD 1344A, METHOD 2005.1
 PROTECTION INDEX: IP 40 AS PER CEI 529
 ROHS COMPLIANT
 SALT MIST : 48Hr PER SAE AS 1344 METHOD 1001.1 CEI 529

OPERATING TEMPERATURE:
 WITH PLASTIC COLLETS: -55°C TO +125°C (-67°F TO +257°F)
 WITH OPTIONAL METALLIC COLLETS: -55°C TO +200°C (-67°F TO +392°F) (ONLY ON REQUEST)

MASS (g)	VOLUME (mm ³)
20.1	3241

NOTES:
 1 ▷ RED DOT.
MATERIAL:
 OUTER SHELL & BACK NUT : } BRASS
 SHIELD RING : }
 HALF BUSHES : }
 COLLET : POLYAMIDE
FINISH:
 OUTER SHELL & BACK NUT : CHROME
 OTHER BRASS PARTS : NICKEL
 T ▷ TOOLS

D

C

B

A

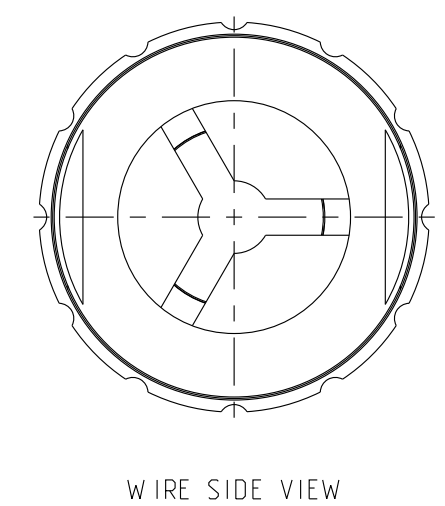
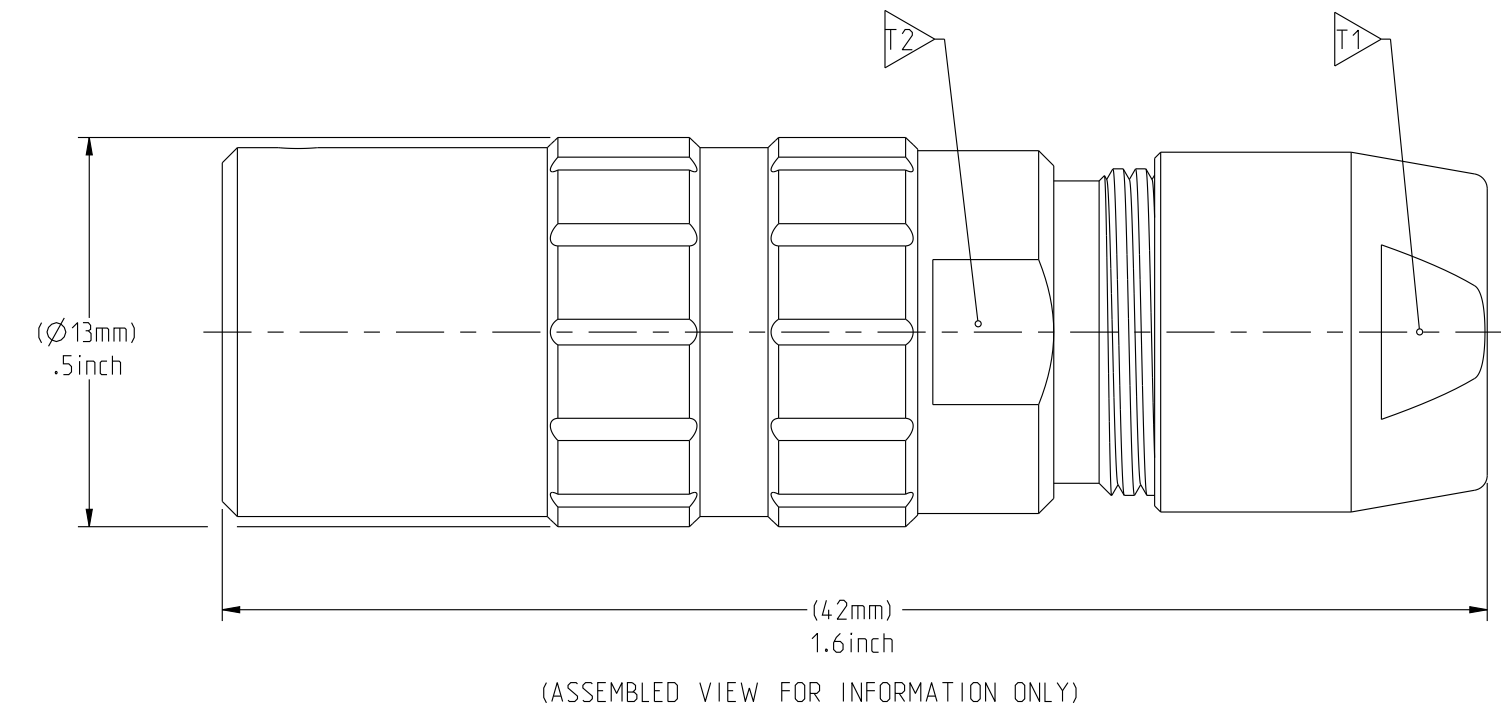
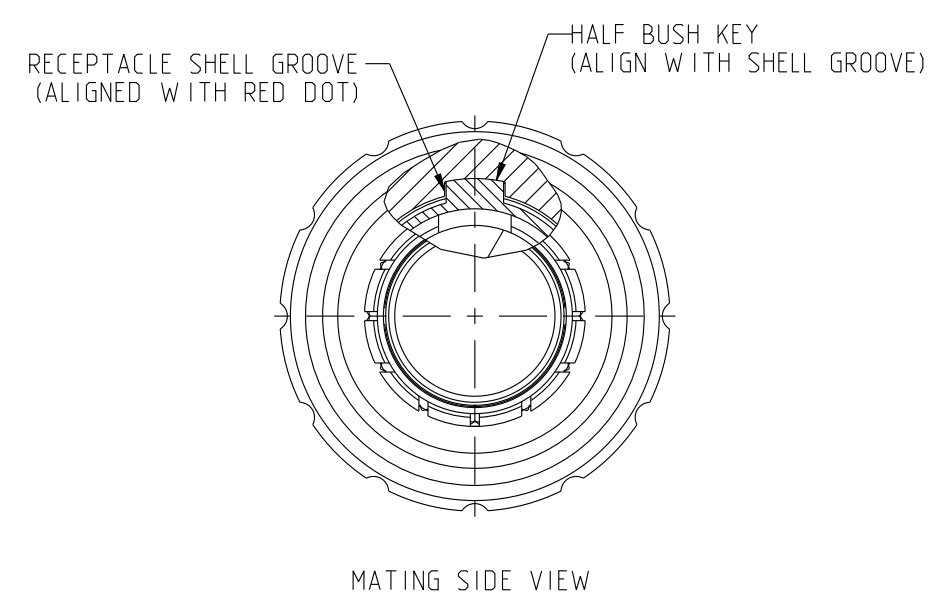

PART LIST	
ITEM NO.	DESCRIPTION
1	RECEPTACLE SHELL
2	HALF BUSHING WITH WINDOW
3	HALF BUSHING WITHOUT WINDOW
4	INSULATOR
5	Ø2-Ø7.5 CABLE COLLET (CHOOSE PER CABLE SIZE)
6	STANDARD BACK NUT
6a	BACK NUT FOR PROTECTIVE BOOT (OPTIONAL)

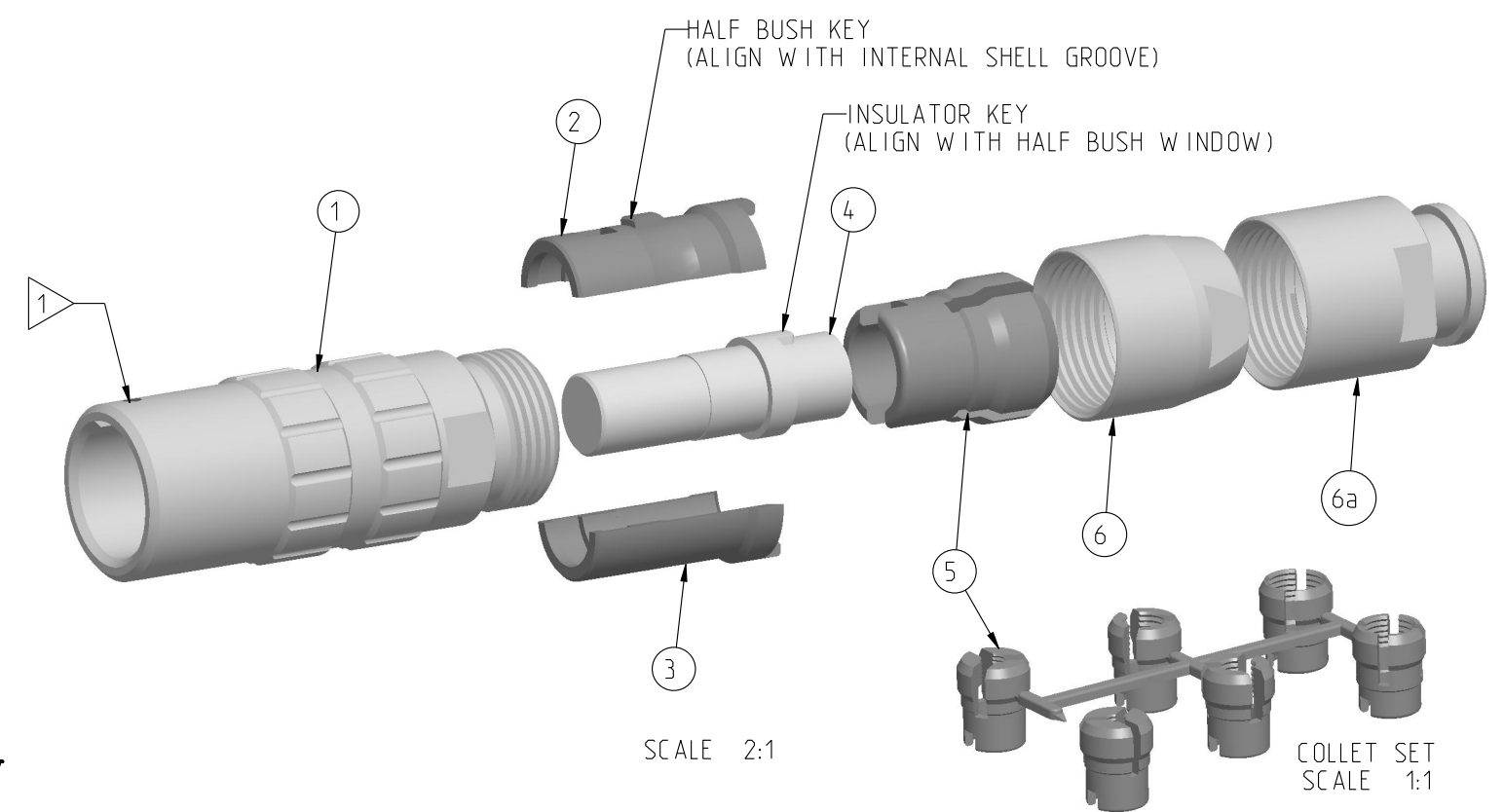

	TOOLS (JAW DIMENSION)	ADVISED TORQUE IN Nm
T1	10	1
T2	11	-

CATALOG NUMBER DESCRIPTION

JBX PC 1 XXXXXX DXX

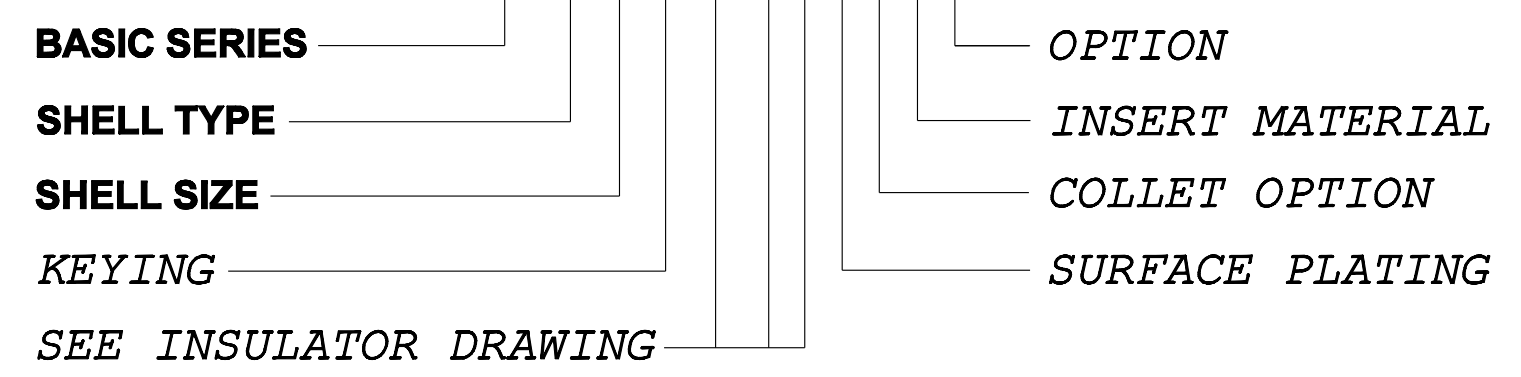

4

3

2

1

PRO-E

ORIGIN	COUNTRY	JURISDICTION	CLASSIFICATION
X	FR	Not listed	N/A
	US	EAR	ECCN =EAR99

These commodities, technology or software are exported from the United States in accordance with the Export Administration Regulations. Diversion contrary to U.S. law is prohibited.

LINEAR MEASURE: $\frac{mm}{INCH}$ mm (INCH)	
THIRD ANGLE PROJECTION	
TOLERANCES UNLESS OTHERWISE SPECIFIED	
No. OF PLACES	mm [INCH]
WHOLE No.	±0.5 [±.02]
ONE PLACE	±0.2 [±.008]
TWO PLACES	±0.1 [±.004]
ANGLES ±1°	

DRAWING TITLE JBX, SIZE 1, CABLE MOUNTED RECEPTACLE		A RELEASED PER ECN 12258 TJS 06-10-15 EV 06-10-15	
CAT NO. JBXPC1		REV DESCRIPTION BY DATE	
CAGE NO: 09922 SIZE: C		DRAWN: SKV 01-08-15	
CUSTOMER		CHKD: EV 01-08-15	
		DSGN: EV 01-08-15	
INTERPRET THIS DRAWING IN ACCORDANCE WITH ASME Y14.5M - 1994.		MFG: DH 01-08-15	
		QC: BB 01-08-15	
www.souriau.com		DRAWING SCALE: 4:1	
		DRAWING NO. REV	
		JBXPC1 A	
		1 OF 1	

DWG. NO.
JBX1INSFSC

FEMALE INSULATOR, SOLDER CONTACT

CONTACT LAYOUT	02	03	04	05
FRONT SIDE VIEW				
REAR SIDE VIEW				
CONTACT				
ISO VIEW				
CONTACT	ØC	1.3	1.3	0.9
	ØF	1.1	1.1	0.8
	MAX. AWG	20	20	24
	MAX. CURRENT RATING (A)	15	15	10
INSULATOR	CONTACT RESISTANCE (mΩ)	3	3	3.5
	NUMBER OF CAVITY	2	3	4
	MAX. CURRENT RATING	15	12	10
	TEST VOLTAGE (Vrms)	1600	1300	1900
WORKING VOLTAGE (Vdc/Vrms)	760/530	600/420	900/630	660/460

CONTACT TYPE : F (FEMALE)
CONTACT TERMINATION : S (SOLDER)
MATERIAL :
 CONTACT: CUPRO NICKEL
 CLIP: COPPER ALLOY
 INSULATOR: PEEK
FINISH :
 CONTACTS: GOLD

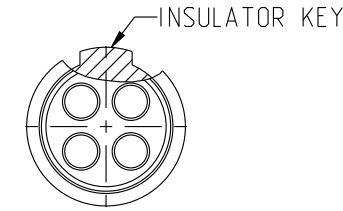

CATALOG NUMBER DESCRIPTION

JBXXX 1 X YY F S XXXX

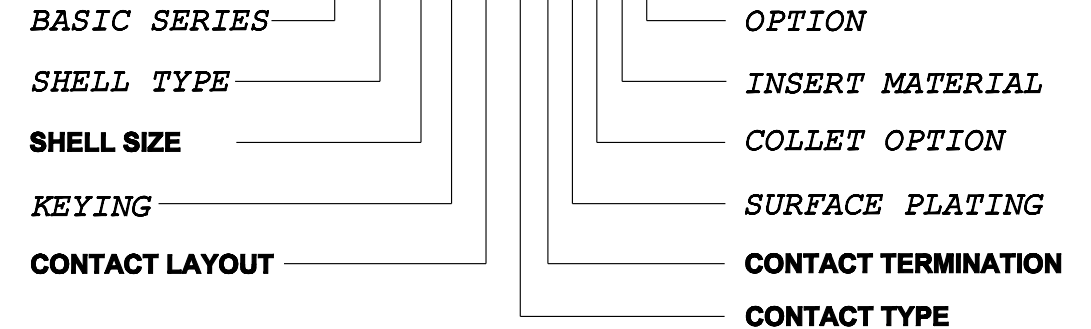

B	REVISED PER ECN 12286	RSK 06-10-15	EV 06-10-15
A	RELEASED PER ECN 12264	SKV 03-10-15	EV 03-10-15
REV	DESCRIPTION	BY DATE	CHKD DATE

DRAWING TITLE
JBX, SIZE 1, FEMALE INSULATOR, SOLDER CONTACT

CAT NO. **JBX1INSFS**

CAGE NO: 09922 SIZE: B

CUSTOMER	SOURIAU	APPROVAL	DRAWN: SKV 02-02-15
		CHKD : EV 02-02-15	
INTERPRET THIS DRAWING IN ACCORDANCE WITH ASME Y14.5M - 1994.	WWW.SOURIAU.COM	DSGN : EV 02-02-15	DRAWING SCALE: NA
		MFG : DH 02-02-15	DRAWING NO. REV
		QC : BB 02-02-15	JBX1INSFSC B
			1 OF 2

ORIGIN	COUNTRY	JURISDICTION	CLASSIFICATION
X	FR	Not listed	N/A
	US	EAR	ECCN =EAR99

These commodities, technology or software are exported from the United States in accordance with the Export Administration Regulations. Diversion contrary to U.S. law is prohibited

LINEAR MEASURE: $\frac{mm}{INCH}$ mm (INCH)
 THIRD ANGLE PROJECTION

 TOLERANCES UNLESS OTHERWISE SPECIFIED
 No. OF PLACES mm [INCH]
 ONE PLACE $\pm 3 [\pm .1]$
 TWO PLACES $\pm 0.5 [\pm .02]$
 THREE PLACES $\pm 0.25 [\pm .010]$
 ANGLES $\pm 1^\circ$

THIS DRAWING IS A CONTROLLED DOCUMENT FOR SOURIAU USA, INC. IT IS SUBJECT TO CHANGE WITHOUT NOTIFICATION. CONTACT THE DOCUMENT CONTROL CENTER FOR THE LATEST REVISION.

THE INFORMATION CONTAINED IN THIS DRAWING IS CONFIDENTIAL AND MAY NOT BE DISCLOSED WITHOUT WRITTEN CONSENT FROM SOURIAU USA, INC.

DWG. NO.
JBX11NSFSC

CONTACT LAYOUT	06	07	08	10	12
FRONT SIDE VIEW					
REAR SIDE VIEW					
CONTACT					
ISO VIEW					
CONTACT	ØC	0.7	0.7	0.7	0.5
	ØF	0.81	0.81	0.81	0.5
	MAX. AWG	22	22	22	28
	MAX. CURRENT RATING (A)	7	7	7	5
INSULATOR	CONTACT RESISTANCE (mΩ)	5	5	5	10
	NUMBER OF CAVITY	6	7	8	10
	MAX. CURRENT RATING	7	7	5	2.5
	TEST VOLTAGE (Vrms)	1400	1400	1200	600
WORKING VOLTAGE (Vdc/Vrms)	660/460	660/460	600/420	300/200	170/120

THIS DRAWING IS A CONTROLLED DOCUMENT FOR SOURIAU USA, INC. IT IS SUBJECT TO CHANGE WITHOUT NOTIFICATION. CONTACT THE DOCUMENT CONTROL CENTER FOR THE LATEST REVISION.

THE INFORMATION CONTAINED IN THIS DRAWING IS CONFIDENTIAL AND MAY NOT BE DISCLOSED WITHOUT WRITTEN CONSENT FROM SOURIAU USA, INC.

B

A

DRAWING TITLE
JBX, SIZE 1, FEMALE INSULATOR, SOLDER CONTACT
CAT NO.

JBX11NSFS

CAGE NO: 09922

SIZE: B

CUSTOMER

SOURIAU

INTERPRET THIS DRAWING IN ACCORDANCE WITH ASME Y14.5M - 1994.

WWW.SOURIAU.COM

APPROVAL	DRAWN:	SKV	02-02-15
	CHKD :	EV	02-02-15
	DSGN :	EV	02-02-15
	MFG :	DH	02-02-15
	QC :	BB	02-02-15
DRAWING SCALE:		NA	
DRAWING NO.		REV	
JBX11NSFSC		B	
2 OF 2			

ORIGIN	COUNTRY	JURISDICTION	CLASSIFICATION
X	FR	Not listed	N/A
	US	EAR	ECCN =EAR99

These commodities, technology or software are exported from the United States in accordance with the Export Administration Regulations. Diversion contrary to U.S. law is prohibited.

LINEAR MEASURE: $\frac{mm}{INCH}$ mm (INCH)

THIRD ANGLE PROJECTION

TOLERANCES UNLESS OTHERWISE SPECIFIED

No. OF PLACES	mm [INCH]
ONE PLACE	±3 [±.1]
TWO PLACES	±0.5 [±.02]
THREE PLACES	±0.25 [±.010]

ANGLES ±1°