

LUXEON CoB Core Range

Uniform, high efficacy and easy to design array

LUXEON CoB represents a new breakthrough for arrays. The efficacies will be >160 lm/W for 70CRI and 80CRI products. Due to its small Light Emitting Surface (LES) and industry-leading thermal resistance, LUXEON CoB is easy to work with, enabling simplified and less expensive luminaire designs. LUXEON CoBs are hot-tested at 85°C—real world operating conditions—which means additional testing can be minimized. LUXEON CoB LEDs are available in 3-step MacAdam ellipse, ensuring uniform optical performance in a wide range of applications.



FEATURES AND BENEFITS

Highest flux densities with industry's smallest LES

3-step MacAdam ellipse color definition: *Freedom from Binning* for color consistency from luminaire to luminaire

Up to 4x lower thermal resistance than competition, enabling smaller heatsinks and higher lumens

Supported by a comprehensive optical, mechanical and electrical ecosystem

PRIMARY APPLICATIONS

Spotlights

Track Lights

Downlights

High Bay

Low Bay

Floodlights

[More...](#)

Table of Contents

| | |
|---|-----------|
| General Product Information | 2 |
| Product Test Conditions | 2 |
| Part Number Nomenclature | 2 |
| Lumen Maintenance | 2 |
| Environmental Compliance | 3 |
| Performance Characteristics | 3 |
| Product Selection Guide | 3 |
| Optical Characteristics | 11 |
| Electrical and Thermal Characteristics | 12 |
| Absolute Maximum Ratings | 12 |
| Characteristic Curves | 13 |
| Spectral Power Distribution Characteristics | 13 |
| Light Output Characteristics | 15 |
| Forward Current Characteristics | 18 |
| Radiation Pattern Characteristics | 21 |
| Color Bin Definitions | 22 |
| Mechanical Dimensions | 23 |
| Packaging and Labeling Information | 25 |
| Tube | 25 |
| Inner Box | 27 |
| Outer Box | 28 |

General Product Information

Product Test Conditions

LUXEON CoB Core Range LEDs are tested and binned with a DC drive current specified below at a junction temperature, T_j , of 85°C:

| | | |
|--------|---|------------------|
| 200mA | - | LUXEON CoB 1202s |
| 200mA | - | LUXEON CoB 1202 |
| 300mA | - | LUXEON CoB 1203 |
| 450mA | - | LUXEON CoB 1204 |
| 600mA | - | LUXEON CoB 1205 |
| 900mA | - | LUXEON CoB 1208 |
| 1200mA | - | LUXEON CoB 1211 |
| 1300mA | - | LUXEON CoB 1213 |
| 1600mA | - | LUXEON CoB 1216 |
| 1200mA | - | LUXEON CoB 1812 |
| 2100mA | - | LUXEON CoB 1321 |
| 2250mA | - | LUXEON CoB 1825 |

Part Number Nomenclature

Part numbers for LUXEON CoB Core Range follow the convention below:

L 2 C 5 – **A A B B C C C C D E E F F**

Where:

- A A** – designates nominal CCT (22=2200K, 27=2700K, 30=3000K, 35=3500K, 40=4000K, 50=5000K, 56=5600K, 57=5700K, 65=6500K)
- B B** – designates minimum CRI (60=60CRI, 70=70CRI, 80=80CRI, 90=90CRI, 95=95CRI)
- C C C C** – designates product configuration (example: 1202, 1203, 1204, 1205, 1208, 1211, 1213, 1216, 1812, 1321, 1825)
- D** – designates options for product specification
- E E** – designates light emitting surface (LES) size (06=6mm, 09=9mm, 13=13mm, 15=15mm, 19=19mm, 23=23mm, 29=29mm, 32=32mm)
- F F** – designates options for product specification

Therefore, the following part number is used for a LUXEON CoB 1203, Gen 4, 3000K 80CRI, with a 9mm LES:

L 2 C 5 – **3 0 8 0 1 2 0 3 F 0 9 0 0**

Lumen Maintenance

Please contact your local Sales Representative or Lumileds Technical Solutions Manager for more information about the long-term performance of this product.

Environmental Compliance

Lumileds LLC is committed to providing environmentally friendly products to the solid-state lighting market. LUXEON CoB Core Range is compliant to the European Union directives on the restriction of hazardous substances in electronic equipment, namely the RoHS Directive 2011/65/EU and REACH Regulation (EC) 1907/2006. Lumileds LLC will not intentionally add the following restricted materials to its products: lead, mercury, cadmium, hexavalent chromium, polybrominated biphenyls (PBB) or polybrominated diphenyl ethers (PBDE).

Performance Characteristics

Product Selection Guide

Table 1. Product performance of LUXEON CoB Core Range at specified test current, $T_j=85^\circ\text{C}$.

| PRODUCT | NOMINAL CCT | MINIMUM CRI ^[1, 2, 3] | LUMINOUS FLUX ^[1] (lm) | | TYPICAL LUMINOUS EFFICACY (lm/W) | TEST CURRENT (mA) | LES ^[4] (mm) | ENERGY EFFICIENCY CLASS ^[5] | PART NUMBER |
|------------------|-------------|----------------------------------|-----------------------------------|---------|----------------------------------|-------------------|-------------------------|--|--------------------|
| | | | MINIMUM | TYPICAL | | | | | |
| LUXEON CoB 1202s | 2200K | 80 | 675 | 750 | 109 | 200 | 6 | F | L2C5-22801202E0600 |
| | 2700K | 80 | 797 | 886 | 128 | 200 | 6 | E | L2C5-27801202E0600 |
| | 3000K | 80 | 837 | 930 | 135 | 200 | 6 | E | L2C5-30801202E0600 |
| | 3500K | 80 | 854 | 949 | 138 | 200 | 6 | E | L2C5-35801202E0600 |
| | 4000K | 80 | 863 | 959 | 139 | 200 | 6 | E | L2C5-40801202E0600 |
| | 5000K | 80 | 863 | 959 | 139 | 200 | 6 | E | L2C5-50801202E0600 |
| | 5700K | 80 | 869 | 966 | 140 | 200 | 6 | E | L2C5-57801202E0600 |
| | 2200K | 90 | 589 | 654 | 95 | 200 | 6 | F | L2C5-22901202E0600 |
| | 2700K | 90 | 662 | 736 | 107 | 200 | 6 | F | L2C5-27901202E0600 |
| | 3000K | 90 | 689 | 766 | 111 | 200 | 6 | F | L2C5-30901202E0600 |
| 3500K | 90 | 725 | 805 | 117 | 200 | 6 | F | L2C5-35901202E0600 | |
| 4000K | 90 | 742 | 824 | 119 | 200 | 6 | E | L2C5-40901202E0600 | |
| LUXEON CoB 1202 | 3000K | 70 | 923 | 1026 | 149 | 200 | 9 | D | L2C5-30701202E0900 |
| | 3500K | 70 | 923 | 1026 | 149 | 200 | 9 | D | L2C5-35701202E0900 |
| | 4000K | 70 | 968 | 1075 | 156 | 200 | 9 | D | L2C5-40701202E0900 |
| | 5000K | 70 | 968 | 1075 | 156 | 200 | 9 | D | L2C5-50701202E0900 |
| | 5700K | 70 | 942 | 1047 | 152 | 200 | 9 | D | L2C5-57701202E0900 |
| | 2200K | 80 | 703 | 781 | 113 | 200 | 9 | F | L2C5-22801202E0900 |
| | 2700K | 80 | 830 | 922 | 134 | 200 | 9 | E | L2C5-27801202E0900 |
| | 3000K | 80 | 876 | 973 | 141 | 200 | 9 | E | L2C5-30801202E0900 |
| | 3500K | 80 | 893 | 992 | 144 | 200 | 9 | E | L2C5-35801202E0900 |
| | 4000K | 80 | 899 | 999 | 145 | 200 | 9 | E | L2C5-40801202E0900 |
| 5000K | 80 | 899 | 999 | 145 | 200 | 9 | E | L2C5-50801202E0900 | |
| 2200K | 90 | 625 | 694 | 101 | 200 | 9 | F | L2C5-22901202E0900 | |
| 2700K | 90 | 689 | 766 | 111 | 200 | 9 | F | L2C5-27901202E0900 | |
| 3000K | 90 | 729 | 810 | 117 | 200 | 9 | F | L2C5-30901202E0900 | |
| 3500K | 90 | 752 | 836 | 121 | 200 | 9 | E | L2C5-35901202E0900 | |
| 4000K | 90 | 772 | 858 | 124 | 200 | 9 | E | L2C5-40901202E0900 | |

Table 1 continued on next page. Notes:

- Lumileds maintains a tolerance of ± 2 on CRI and $\pm 6.5\%$ on luminous flux measurements.
- Typical CRI is approximately 2 points higher than the minimum CRI specified, but this is not guaranteed.
- R9 value of 90CRI products is >50 .
- Light Emitting Surface (LES) is the inner diameter (phosphor area) inside the dam.
- Energy efficiency class as specified in Commission Delegated Regulation (EU) 2019/2015. The available range of energy efficiency classes is A-G.
- Exception: Not available in EU or UK.

Table 1. Product performance of LUXEON CoB Core Range at specified test current, T_j=85°C (continued).

| PRODUCT | NOMINAL CCT | MINIMUM CRI ^[1, 2, 3] | LUMINOUS FLUX ^[1] (lm) | | TYPICAL LUMINOUS EFFICACY (lm/W) | TEST CURRENT (mA) | LES ^[4] (mm) | ENERGY EFFICIENCY CLASS ^[5] | PART NUMBER |
|-----------------------|-------------|----------------------------------|-----------------------------------|---------|----------------------------------|-------------------|-------------------------|--|--------------------|
| | | | MINIMUM | TYPICAL | | | | | |
| LUXEON CoB 1203 | 3000K | 70 | 1475 | 1639 | 160 | 300 | 9 | D | L2C5-30701203F0900 |
| | | 70 | 1379 | 1532 | 148 | 300 | 9 | D | L2C5-30701203E0900 |
| | 3500K | 70 | 1379 | 1532 | 148 | 300 | 9 | D | L2C5-35701203E0900 |
| | 4000K | 70 | 1569 | 1743 | 170 | 300 | 9 | D | L2C5-40701203F0900 |
| | | 70 | 1466 | 1629 | 157 | 300 | 9 | D | L2C5-40701203E0900 |
| | 5000K | 70 | 1466 | 1629 | 157 | 300 | 9 | D | L2C5-50701203E0900 |
| | 5700K | 70 | 1428 | 1587 | 153 | 300 | 9 | D | L2C5-57701203E0900 |
| | 6500K | 70 | 1391 | 1546 | 149 | 300 | 9 | D | L2C5-65701203E0900 |
| | 2200K | 80 | 1066 | 1184 | 114 | 300 | 9 | F | L2C5-22801203E0900 |
| | 2700K | 80 | 1359 | 1510 | 147 | 300 | 9 | D | L2C5-27801203F0900 |
| | | 80 | 1258 | 1398 | 135 | 300 | 9 | E | L2C5-27801203E0900 |
| | 3000K | 80 | 1392 | 1547 | 151 | 300 | 9 | D | L2C5-30801203F0900 |
| | | 80 | 1289 | 1432 | 138 | 300 | 9 | E | L2C5-30801203E0900 |
| | 3500K | 80 | 1420 | 1578 | 154 | 300 | 9 | D | L2C5-35801203F0900 |
| | | 80 | 1315 | 1461 | 141 | 300 | 9 | E | L2C5-35801203E0900 |
| | 4000K | 80 | 1472 | 1635 | 159 | 300 | 9 | D | L2C5-40801203F0900 |
| | | 80 | 1363 | 1514 | 146 | 300 | 9 | D | L2C5-40801203E0900 |
| | 5000K | 80 | 1472 | 1635 | 159 | 300 | 9 | D | L2C5-50801203F0900 |
| | | 80 | 1363 | 1514 | 146 | 300 | 9 | D | L2C5-50801203E0900 |
| | 5700K | 80 | 1359 | 1510 | 146 | 300 | 9 | D | L2C5-57801203E0900 |
| | 2200K | 90 | 929 | 1032 | 100 | 300 | 9 | F | L2C5-22901203E0900 |
| | 2700K | 90 | 1170 | 1300 | 127 | 300 | 9 | E | L2C5-27901203F0900 |
| | | 90 | 1045 | 1161 | 112 | 300 | 9 | F | L2C5-27901203E0900 |
| | 3000K | 90 | 1210 | 1344 | 131 | 300 | 9 | E | L2C5-30901203F0900 |
| | | 90 | 1080 | 1200 | 116 | 300 | 9 | F | L2C5-30901203E0900 |
| | 3500K | 90 | 1258 | 1398 | 136 | 300 | 9 | E | L2C5-35901203F0900 |
| | | 90 | 1140 | 1267 | 122 | 300 | 9 | E | L2C5-35901203E0900 |
| | 4000K | 90 | 1251 | 1390 | 135 | 300 | 9 | E | L2C5-40901203F0900 |
| | | 90 | 1171 | 1301 | 126 | 300 | 9 | E | L2C5-40901203E0900 |
| | 2700K | 95 | 999 | 1110 | 108 | 300 | 9 | F | L2C5-27951203F0900 |
| 3000K | 95 | 1053 | 1170 | 114 | 300 | 9 | F | L2C5-30951203F0900 | |
| 4000K | 95 | 1194 | 1327 | 129 | 300 | 9 | E | L2C5-40951203F0900 | |

Table 1 continued on next page. Notes:

1. Lumileds maintains a tolerance of ±2 on CRI and ±6.5% on luminous flux measurements.
2. Typical CRI is approximately 2 points higher than the minimum CRI specified, but this is not guaranteed.
3. R9 value of 90CRI products is >50.
4. Light Emitting Surface (LES) is the inner diameter (phosphor area) inside the dam.
5. Energy efficiency class as specified in Commission Delegated Regulation (EU) 2019/2015. The available range of energy efficiency classes is A-G.
6. Exception: Not available in EU or UK.

Table 1. Product performance of LUXEON CoB Core Range at specified test current, T_j=85°C (continued).

| PRODUCT | NOMINAL CCT | MINIMUM CRI ^[1, 2, 3] | LUMINOUS FLUX ^[1] (lm) | | TYPICAL LUMINOUS EFFICACY (lm/W) | TEST CURRENT (mA) | LES ^[4] (mm) | ENERGY EFFICIENCY CLASS ^[5] | PART NUMBER |
|-----------------|----------------------|----------------------------------|-----------------------------------|---------|----------------------------------|-------------------|-------------------------|--|--------------------|
| | | | MINIMUM | TYPICAL | | | | | |
| LUXEON CoB 1204 | 3000K | 70 | 2124 | 2360 | 151 | 450 | 13 | D | L2C5-30701204E1300 |
| | 3500K | 70 | 2124 | 2360 | 151 | 450 | 13 | D | L2C5-35701204E1300 |
| | 4000K | 70 | 2258 | 2509 | 161 | 450 | 13 | D | L2C5-40701204E1300 |
| | 5000K | 70 | 2258 | 2509 | 161 | 450 | 13 | D | L2C5-50701204E1300 |
| | 5700K | 70 | 2199 | 2443 | 156 | 450 | 13 | D | L2C5-57701204E1300 |
| | 6500K | 70 | 2142 | 2380 | 152 | 450 | 13 | D | L2C5-65701204E1300 |
| | 2200K | 80 | 1641 | 1823 | 117 | 450 | 13 | F | L2C5-22801204E1300 |
| | 2700K | 80 | 2092 | 2324 | 149 | 450 | 13 | D | L2C5-27801204F1300 |
| | | 80 | 1937 | 2152 | 138 | 450 | 13 | E | L2C5-27801204E1300 |
| | 3000K | 80 | 2138 | 2376 | 152 | 450 | 13 | D | L2C5-30801204F1300 |
| | | 80 | 1980 | 2200 | 141 | 450 | 13 | E | L2C5-30801204E1300 |
| | 3500K | 80 | 2020 | 2244 | 144 | 450 | 13 | E | L2C5-35801204E1300 |
| | 4000K | 80 | 2260 | 2511 | 161 | 450 | 13 | D | L2C5-40801204F1300 |
| | | 80 | 2099 | 2332 | 149 | 450 | 13 | D | L2C5-40801204E1300 |
| | 5000K | 80 | 2099 | 2332 | 149 | 450 | 13 | D | L2C5-50801204E1300 |
| | 5700K | 80 | 2093 | 2325 | 149 | 450 | 13 | D | L2C5-57801204E1300 |
| | 2200K ^[5] | 90 | 1430 | 1589 | 102 | 450 | 13 | F | L2C5-22901204E1300 |
| | 2700K | 90 | 1803 | 2003 | 128 | 450 | 13 | E | L2C5-27901204F1300 |
| | | 90 | 1609 | 1788 | 115 | 450 | 13 | F | L2C5-27901204E1300 |
| | 3000K | 90 | 1855 | 2061 | 132 | 450 | 13 | E | L2C5-30901204F1300 |
| | | 90 | 1656 | 1840 | 118 | 450 | 13 | F | L2C5-30901204E1300 |
| | 3500K | 90 | 1929 | 2143 | 137 | 450 | 13 | E | L2C5-35901204F1300 |
| | | 90 | 1755 | 1950 | 125 | 450 | 13 | E | L2C5-35901204E1300 |
| | 4000K | 90 | 1803 | 2003 | 128 | 450 | 13 | E | L2C5-40901204E1300 |

Table 1 continued on next page. Notes:

1. Lumileds maintains a tolerance of ±2 on CRI and ±6.5% on luminous flux measurements.
2. Typical CRI is approximately 2 points higher than the minimum CRI specified, but this is not guaranteed.
3. R9 value of 90CRI products is >50.
4. Light Emitting Surface (LES) is the inner diameter (phosphor area) inside the dam.
5. Energy efficiency class as specified in Commission Delegated Regulation (EU) 2019/2015. The available range of energy efficiency classes is A-G.
6. Exception: Not available in EU or UK.

Table 1. Product performance of LUXEON CoB Core Range at specified test current, T_j=85°C (continued).

| PRODUCT | NOMINAL CCT | MINIMUM CRI ^[1, 2, 3] | LUMINOUS FLUX ^[1] (lm) | | TYPICAL LUMINOUS EFFICACY (lm/W) | TEST CURRENT (mA) | LES ^[4] (mm) | ENERGY EFFICIENCY CLASS ^[5] | PART NUMBER |
|-----------------|-------------|----------------------------------|-----------------------------------|---------|----------------------------------|-------------------|-------------------------|--|--------------------|
| | | | MINIMUM | TYPICAL | | | | | |
| LUXEON CoB 1205 | 3000K | 70 | 2958 | 3287 | 158 | 600 | 13 | D | L2C5-30701205F1300 |
| | | 70 | 2765 | 3072 | 146 | 600 | 13 | D | L2C5-30701205E1300 |
| | 3500K | 70 | 2765 | 3072 | 146 | 600 | 13 | D | L2C5-35701205E1300 |
| | 4000K | 70 | 3137 | 3486 | 167 | 600 | 13 | D | L2C5-40701205F1300 |
| | | 70 | 2932 | 3258 | 155 | 600 | 13 | D | L2C5-40701205E1300 |
| | 5000K | 70 | 2932 | 3258 | 155 | 600 | 13 | D | L2C5-50701205E1300 |
| | 5700K | 70 | 2856 | 3173 | 151 | 600 | 13 | D | L2C5-57701205E1300 |
| | 6500K | 70 | 2782 | 3091 | 147 | 600 | 13 | D | L2C5-65701205E1300 |
| | 2200K | 80 | 2131 | 2368 | 113 | 600 | 13 | F | L2C5-22801205E1300 |
| | 2700K | 80 | 2717 | 3019 | 145 | 600 | 13 | E | L2C5-27801205F1300 |
| | | 80 | 2516 | 2795 | 133 | 600 | 13 | E | L2C5-27801205E1300 |
| | 3000K | 80 | 2823 | 3137 | 151 | 600 | 13 | D | L2C5-30801205F1300 |
| | | 80 | 2615 | 2905 | 138 | 600 | 13 | E | L2C5-30801205E1300 |
| | 3500K | 80 | 2880 | 3200 | 154 | 600 | 13 | D | L2C5-35801205F1300 |
| | | 80 | 2667 | 2963 | 141 | 600 | 13 | E | L2C5-35801205E1300 |
| | 4000K | 80 | 2943 | 3270 | 157 | 600 | 13 | D | L2C5-40801205F1300 |
| | | 80 | 2725 | 3028 | 144 | 600 | 13 | E | L2C5-40801205E1300 |
| | 5000K | 80 | 2943 | 3270 | 157 | 600 | 13 | D | L2C5-50801205F1300 |
| | | 80 | 2725 | 3028 | 144 | 600 | 13 | E | L2C5-50801205E1300 |
| | 5700K | 80 | 2935 | 3261 | 157 | 600 | 13 | D | L2C5-57801205F1300 |
| | | 80 | 2717 | 3019 | 144 | 600 | 13 | E | L2C5-57801205E1300 |
| | 6500K | 80 | 2861 | 3179 | 153 | 600 | 13 | D | L2C5-65801205F1300 |
| | 2200K | 90 | 1857 | 2063 | 98 | 600 | 13 | Note 6 | L2C5-22901205E1300 |
| | 2700K | 90 | 2340 | 2600 | 125 | 600 | 13 | E | L2C5-27901205F1300 |
| | | 90 | 2090 | 2322 | 111 | 600 | 13 | F | L2C5-27901205E1300 |
| | 3000K | 90 | 2437 | 2708 | 130 | 600 | 13 | E | L2C5-30901205F1300 |
| | | 90 | 2176 | 2418 | 115 | 600 | 13 | F | L2C5-30901205E1300 |
| | 3500K | 90 | 2534 | 2816 | 135 | 600 | 13 | E | L2C5-35901205F1300 |
| | | 90 | 2280 | 2533 | 121 | 600 | 13 | E | L2C5-35901205E1300 |
| | 4000K | 90 | 2622 | 2913 | 140 | 600 | 13 | E | L2C5-40901205F1300 |
| 90 | | 2341 | 2601 | 124 | 600 | 13 | E | L2C5-40901205E1300 | |
| 5000K | 90 | 2623 | 2914 | 140 | 600 | 13 | E | L2C5-50901205F1300 | |
| 2700K | 95 | 2007 | 2230 | 107 | 600 | 13 | F | L2C5-27951205F1300 | |
| 3000K | 95 | 2160 | 2400 | 115 | 600 | 13 | F | L2C5-30951205F1300 | |
| 4000K | 95 | 2434 | 2704 | 130 | 600 | 13 | E | L2C5-40951205F1300 | |

Table 1 continued on next page. Notes:

1. Lumileds maintains a tolerance of ±2 on CRI and ±6.5% on luminous flux measurements.
2. Typical CRI is approximately 2 points higher than the minimum CRI specified, but this is not guaranteed.
3. R9 value of 90CRI products is >50.
4. Light Emitting Surface (LES) is the inner diameter (phosphor area) inside the dam.
5. Energy efficiency class as specified in Commission Delegated Regulation (EU) 2019/2015. The available range of energy efficiency classes is A-G.
6. Exception: Not available in EU or UK.

Table 1. Product performance of LUXEON CoB Core Range at specified test current, T_j=85°C (continued).

| PRODUCT | NOMINAL CCT | MINIMUM CRI ^[1, 2, 3] | LUMINOUS FLUX ^[1] (lm) | | TYPICAL LUMINOUS EFFICACY (lm/W) | TEST CURRENT (mA) | LES ^[4] (mm) | ENERGY EFFICIENCY CLASS ^[5] | PART NUMBER |
|-----------------------|-------------|----------------------------------|-----------------------------------|---------|----------------------------------|-------------------|-------------------------|--|--------------------|
| | | | MINIMUM | TYPICAL | | | | | |
| LUXEON CoB 1208 | 3000K | 70 | 4440 | 4933 | 158 | 900 | 15 | D | L2C5-30701208F1500 |
| | | 70 | 4149 | 4610 | 147 | 900 | 15 | D | L2C5-30701208E1500 |
| | 3500K | 70 | 4149 | 4610 | 147 | 900 | 15 | D | L2C5-35701208E1500 |
| | 4000K | 70 | 4719 | 5243 | 168 | 900 | 15 | D | L2C5-40701208F1500 |
| | | 70 | 4410 | 4900 | 156 | 900 | 15 | D | L2C5-40701208E1500 |
| | 5000K | 70 | 4719 | 5243 | 168 | 900 | 15 | D | L2C5-50701208F1500 |
| | | 70 | 4410 | 4900 | 156 | 900 | 15 | D | L2C5-50701208E1500 |
| | 5700K | 70 | 4584 | 5093 | 163 | 900 | 15 | D | L2C5-57701208F1500 |
| | | 70 | 4284 | 4760 | 152 | 900 | 15 | D | L2C5-57701208E1500 |
| | 6500K | 70 | 4466 | 4962 | 159 | 900 | 15 | D | L2C5-65701208F1500 |
| | | 70 | 4173 | 4637 | 148 | 900 | 15 | D | L2C5-65701208E1500 |
| | 2200K | 80 | 3197 | 3552 | 113 | 900 | 15 | Note 6 | L2C5-22801208E1500 |
| | 2700K | 80 | 4075 | 4528 | 145 | 900 | 15 | E | L2C5-27801208F1500 |
| | | 80 | 3774 | 4193 | 134 | 900 | 15 | E | L2C5-27801208E1500 |
| | 3000K | 80 | 4245 | 4717 | 151 | 900 | 15 | D | L2C5-30801208F1500 |
| | | 80 | 3931 | 4368 | 139 | 900 | 15 | E | L2C5-30801208E1500 |
| | 3500K | 80 | 4330 | 4811 | 154 | 900 | 15 | D | L2C5-35801208F1500 |
| | | 80 | 4010 | 4455 | 142 | 900 | 15 | E | L2C5-35801208E1500 |
| | 4000K | 80 | 4415 | 4905 | 157 | 900 | 15 | D | L2C5-40801208F1500 |
| | | 80 | 4088 | 4542 | 145 | 900 | 15 | E | L2C5-40801208E1500 |
| | 5000K | 80 | 4415 | 4905 | 157 | 900 | 15 | D | L2C5-50801208F1500 |
| | | 80 | 4088 | 4542 | 145 | 900 | 15 | E | L2C5-50801208E1500 |
| | 5700K | 80 | 4402 | 4891 | 157 | 900 | 15 | D | L2C5-57801208F1500 |
| | | 80 | 4076 | 4529 | 145 | 900 | 15 | E | L2C5-57801208E1500 |
| | 6500K | 80 | 4292 | 4769 | 153 | 900 | 15 | D | L2C5-65801208F1500 |
| | 2200K | 90 | 2786 | 3095 | 99 | 900 | 15 | Note 6 | L2C5-22901208E1500 |
| | 2700K | 90 | 3514 | 3904 | 125 | 900 | 15 | E | L2C5-27901208F1500 |
| | | 90 | 3137 | 3486 | 111 | 900 | 15 | F | L2C5-27901208E1500 |
| | 3000K | 90 | 3639 | 4043 | 129 | 900 | 15 | E | L2C5-30901208F1500 |
| | | 90 | 3249 | 3610 | 115 | 900 | 15 | F | L2C5-30901208E1500 |
| 3500K | 90 | 3785 | 4205 | 135 | 900 | 15 | E | L2C5-35901208F1500 | |
| | 90 | 3420 | 3800 | 121 | 900 | 15 | E | L2C5-35901208E1500 | |
| 4000K | 90 | 3933 | 4370 | 140 | 900 | 15 | E | L2C5-40901208F1500 | |
| | 90 | 3512 | 3902 | 125 | 900 | 15 | E | L2C5-40901208E1500 | |
| 2700K | 95 | 3015 | 3350 | 107 | 900 | 15 | F | L2C5-27951208F1500 | |
| 3000K | 95 | 3240 | 3600 | 115 | 900 | 15 | F | L2C5-30951208F1500 | |
| 4000K | 95 | 3572 | 3969 | 127 | 900 | 15 | E | L2C5-40951208F1500 | |

Table 1 continued on next page. Notes:

1. Lumileds maintains a tolerance of ±2 on CRI and ±6.5% on luminous flux measurements.
2. Typical CRI is approximately 2 points higher than the minimum CRI specified, but this is not guaranteed.
3. R9 value of 90CRI products is >50.
4. Light Emitting Surface (LES) is the inner diameter (phosphor area) inside the dam.
5. Energy efficiency class as specified in Commission Delegated Regulation (EU) 2019/2015. The available range of energy efficiency classes is A-G.
6. Exception: Not available in EU or UK.

Table 1. Product performance of LUXEON CoB Core Range at specified test current, T_j=85°C (continued).

| PRODUCT | NOMINAL CCT | MINIMUM CRI ^[1, 2, 3] | LUMINOUS FLUX ^[1] (lm) | | TYPICAL LUMINOUS EFFICACY (lm/W) | TEST CURRENT (mA) | LES ^[4] (mm) | ENERGY EFFICIENCY CLASS ^[5] | PART NUMBER |
|-----------------|-------------|----------------------------------|-----------------------------------|---------|----------------------------------|-------------------|-------------------------|--|--------------------|
| | | | MINIMUM | TYPICAL | | | | | |
| LUXEON CoB 1211 | 3000K | 70 | 6065 | 6739 | 164 | 1200 | 19 | D | L2C5-30701211F1900 |
| | | 70 | 5695 | 6328 | 152 | 1200 | 19 | D | L2C5-30701211E1900 |
| | 3500K | 70 | 5695 | 6328 | 152 | 1200 | 19 | D | L2C5-35701211E1900 |
| | 4000K | 70 | 6447 | 7163 | 174 | 1200 | 19 | C | L2C5-40701211F1900 |
| | | 70 | 6053 | 6726 | 161 | 1200 | 19 | D | L2C5-40701211E1900 |
| | 5000K | 70 | 6447 | 7163 | 174 | 1200 | 19 | C | L2C5-50701211F1900 |
| | | 70 | 6053 | 6726 | 161 | 1200 | 19 | D | L2C5-50701211E1900 |
| | 5700K | 70 | 6265 | 6961 | 169 | 1200 | 19 | D | L2C5-57701211F1900 |
| | | 70 | 5882 | 6536 | 157 | 1200 | 19 | D | L2C5-57701211E1900 |
| | 6500K | 70 | 6104 | 6782 | 165 | 1200 | 19 | D | L2C5-65701211F1900 |
| | | 70 | 5731 | 6368 | 152 | 1200 | 19 | D | L2C5-65701211E1900 |
| | 2200K | 80 | 4390 | 4878 | 117 | 1200 | 19 | F | L2C5-22801211E1900 |
| | 2700K | 80 | 5519 | 6132 | 149 | 1200 | 19 | D | L2C5-27801211F1900 |
| | | 80 | 5182 | 5758 | 138 | 1200 | 19 | E | L2C5-27801211E1900 |
| | 3000K | 80 | 5675 | 6305 | 153 | 1200 | 19 | D | L2C5-30801211F1900 |
| | | 80 | 5328 | 5920 | 142 | 1200 | 19 | E | L2C5-30801211E1900 |
| | 3500K | 80 | 5787 | 6430 | 156 | 1200 | 19 | D | L2C5-35801211F1900 |
| | | 80 | 5434 | 6038 | 145 | 1200 | 19 | E | L2C5-35801211E1900 |
| | 4000K | 80 | 5979 | 6643 | 161 | 1200 | 19 | D | L2C5-40801211F1900 |
| | | 80 | 5614 | 6238 | 149 | 1200 | 19 | D | L2C5-40801211E1900 |
| | 5000K | 80 | 5979 | 6643 | 161 | 1200 | 19 | D | L2C5-50801211F1900 |
| | | 80 | 5614 | 6238 | 149 | 1200 | 19 | D | L2C5-50801211E1900 |
| | 5700K | 80 | 5962 | 6624 | 161 | 1200 | 19 | D | L2C5-57801211F1900 |
| | | 80 | 5598 | 6220 | 149 | 1200 | 19 | D | L2C5-57801211E1900 |
| | 6500K | 80 | 5661 | 6290 | 153 | 1200 | 19 | D | L2C5-65801211F1900 |
| | 2200K | 90 | 3749 | 4165 | 100 | 1200 | 19 | Note 6 | L2C5-22901211E1900 |
| | 2700K | 90 | 4692 | 5213 | 127 | 1200 | 19 | E | L2C5-27901211F1900 |
| | | 90 | 4305 | 4783 | 115 | 1200 | 19 | F | L2C5-27901211E1900 |
| | 3000K | 90 | 4910 | 5455 | 133 | 1200 | 19 | E | L2C5-30901211F1900 |
| | | 90 | 4505 | 5005 | 120 | 1200 | 19 | E | L2C5-30901211E1900 |
| 3500K | 90 | 5119 | 5688 | 138 | 1200 | 19 | E | L2C5-35901211F1900 | |
| | 90 | 4696 | 5218 | 125 | 1200 | 19 | E | L2C5-35901211E1900 | |
| 4000K | 90 | 5256 | 5840 | 142 | 1200 | 19 | E | L2C5-40901211F1900 | |
| | 90 | 4822 | 5358 | 128 | 1200 | 19 | E | L2C5-40901211E1900 | |
| 5000K | 90 | 5256 | 5840 | 142 | 1200 | 19 | E | L2C5-50901211F1900 | |
| 2700K | 95 | 4032 | 4480 | 109 | 1200 | 19 | F | L2C5-27951211F1910 | |
| 3000K | 95 | 4221 | 4690 | 114 | 1200 | 19 | F | L2C5-30951211F1910 | |
| LUXEON CoB 1213 | 5000K | 70 | 7072 | 7858 | 177 | 1300 | 23 | C | L2C5-50701213F2300 |
| | 3000K | 80 | 6188 | 6875 | 155 | 1300 | 23 | D | L2C5-30801213F2300 |
| | 4000K | 80 | 6623 | 7359 | 166 | 1300 | 23 | D | L2C5-40801213F2300 |

Table 1 continued on next page. Notes:

1. Lumileds maintains a tolerance of ±2 on CRI and ±6.5% on luminous flux measurements.
2. Typical CRI is approximately 2 points higher than the minimum CRI specified, but this is not guaranteed.
3. R9 value of 90CRI products is >50.
4. Light Emitting Surface (LES) is the inner diameter (phosphor area) inside the dam.
5. Energy efficiency class as specified in Commission Delegated Regulation (EU) 2019/2015. The available range of energy efficiency classes is A-G.
6. Exception: Not available in EU or UK.

Table 1. Product performance of LUXEON CoB Core Range at specified test current, T_j=85°C (continued).

| PRODUCT | NOMINAL CCT | MINIMUM CRI ^[1, 2, 3] | LUMINOUS FLUX ^[1] (lm) | | TYPICAL LUMINOUS EFFICACY (lm/W) | TEST CURRENT (mA) | LES ^[4] (mm) | ENERGY EFFICIENCY CLASS ^[5] | PART NUMBER |
|-----------------------|-------------|----------------------------------|-----------------------------------|---------|----------------------------------|-------------------|-------------------------|--|--------------------|
| | | | MINIMUM | TYPICAL | | | | | |
| LUXEON CoB 1216 | 3000K | 70 | 7988 | 8875 | 163 | 1600 | 23 | D | L2C5-30701216F2300 |
| | | 70 | 7465 | 8294 | 150 | 1600 | 23 | D | L2C5-30701216E2300 |
| | 3500K | 70 | 7465 | 8294 | 150 | 1600 | 23 | D | L2C5-35701216E2300 |
| | 4000K | 70 | 8428 | 9364 | 172 | 1600 | 23 | D | L2C5-40701216F2300 |
| | | 70 | 7876 | 8751 | 159 | 1600 | 23 | D | L2C5-40701216E2300 |
| | 5000K | 70 | 8428 | 9364 | 172 | 1600 | 23 | D | L2C5-50701216F2300 |
| | | 70 | 7876 | 8751 | 159 | 1600 | 23 | D | L2C5-50701216E2300 |
| | 5700K | 70 | 8250 | 9167 | 169 | 1600 | 23 | D | L2C5-57701216F2300 |
| | | 70 | 7710 | 8567 | 155 | 1600 | 23 | D | L2C5-57701216E2300 |
| | 6500K | 70 | 8038 | 8931 | 164 | 1600 | 23 | D | L2C5-65701216F2300 |
| | | 70 | 7512 | 8347 | 151 | 1600 | 23 | D | L2C5-65701216E2300 |
| | 2200K | 80 | 5755 | 6394 | 116 | 1600 | 23 | Note 6 | L2C5-22801216E2300 |
| | 2700K | 80 | 7335 | 8150 | 150 | 1600 | 23 | D | L2C5-27801216F2300 |
| | | 80 | 6791 | 7546 | 137 | 1600 | 23 | E | L2C5-27801216E2300 |
| | 3000K | 80 | 7508 | 8342 | 153 | 1600 | 23 | D | L2C5-30801216F2300 |
| | | 80 | 6952 | 7724 | 140 | 1600 | 23 | E | L2C5-30801216E2300 |
| | 3500K | 80 | 7657 | 8508 | 156 | 1600 | 23 | D | L2C5-35801216F2300 |
| | | 80 | 7090 | 7878 | 143 | 1600 | 23 | E | L2C5-35801216E2300 |
| | 4000K | 80 | 7947 | 8830 | 162 | 1600 | 23 | D | L2C5-40801216F2300 |
| | | 80 | 7358 | 8176 | 148 | 1600 | 23 | D | L2C5-40801216E2300 |
| | 5000K | 80 | 7947 | 8830 | 162 | 1600 | 23 | D | L2C5-50801216F2300 |
| | | 80 | 7358 | 8176 | 148 | 1600 | 23 | D | L2C5-50801216E2300 |
| | 5700K | 80 | 7923 | 8803 | 162 | 1600 | 23 | D | L2C5-57801216F2300 |
| | | 80 | 7336 | 8151 | 148 | 1600 | 23 | D | L2C5-57801216E2300 |
| | 2200K | 90 | 5013 | 5570 | 101 | 1600 | 23 | Note 6 | L2C5-22901216E2300 |
| | 2700K | 90 | 6319 | 7021 | 129 | 1600 | 23 | E | L2C5-27901216F2300 |
| | | 90 | 5642 | 6269 | 114 | 1600 | 23 | F | L2C5-27901216E2300 |
| | 3000K | 90 | 6570 | 7300 | 134 | 1600 | 23 | E | L2C5-30901216F2300 |
| | | 90 | 5866 | 6518 | 118 | 1600 | 23 | F | L2C5-30901216E2300 |
| | 3500K | 90 | 6893 | 7659 | 141 | 1600 | 23 | E | L2C5-35901216F2300 |
| 90 | | 6155 | 6839 | 124 | 1600 | 23 | E | L2C5-35901216E2300 | |
| 4000K | 90 | 6893 | 7659 | 141 | 1600 | 23 | E | L2C5-40901216F2300 | |
| | 90 | 6321 | 7023 | 127 | 1600 | 23 | E | L2C5-40901216E2300 | |
| 5000K | 90 | 6954 | 7727 | 142 | 1600 | 23 | E | L2C5-50901216F2300 | |

Table 1 continued on next page. Notes:

1. Lumileds maintains a tolerance of ±2 on CRI and ±6.5% on luminous flux measurements.
2. Typical CRI is approximately 2 points higher than the minimum CRI specified, but this is not guaranteed.
3. R9 value of 90CRI products is >50.
4. Light Emitting Surface (LES) is the inner diameter (phosphor area) inside the dam.
5. Energy efficiency class as specified in Commission Delegated Regulation (EU) 2019/2015. The available range of energy efficiency classes is A-G.
6. Exception: Not available in EU or UK.

Table 1. Product performance of LUXEON CoB Core Range at specified test current, T_j=85°C (continued).

| PRODUCT | NOMINAL CCT | MINIMUM CRI ^[1, 2, 3] | LUMINOUS FLUX ^[1] (lm) | | TYPICAL LUMINOUS EFFICACY (lm/W) | TEST CURRENT (mA) | LES ^[4] (mm) | ENERGY EFFICIENCY CLASS ^[5] | PART NUMBER |
|-----------------|-------------|----------------------------------|-----------------------------------|---------|----------------------------------|-------------------|-------------------------|--|--------------------|
| | | | MINIMUM | TYPICAL | | | | | |
| LUXEON CoB 1812 | 4000K | 70 | 9356 | 10395 | 170 | 1200 | 23 | D | L2C5-40701812F2300 |
| | | 70 | 9000 | 10000 | 161 | 1200 | 23 | D | L2C5-40701812G2300 |
| | 5000K | 70 | 9450 | 10500 | 171 | 1200 | 23 | D | L2C5-50701812F2300 |
| | | 70 | 9000 | 10000 | 161 | 1200 | 23 | D | L2C5-50701812G2300 |
| | 3000K | 80 | 8221 | 9134 | 149 | 1200 | 23 | D | L2C5-30801812F2300 |
| | | 80 | 7682 | 8536 | 138 | 1200 | 23 | E | L2C5-30801812G2300 |
| | 4000K | 80 | 8691 | 9657 | 157 | 1200 | 23 | D | L2C5-40801812F2300 |
| | | 80 | 8123 | 9025 | 145 | 1200 | 23 | E | L2C5-40801812G2300 |
| | 5000K | 80 | 8814 | 9793 | 160 | 1200 | 23 | D | L2C5-50801812F2300 |
| | | 80 | 8123 | 9025 | 145 | 1200 | 23 | E | L2C5-50801812G2300 |
| LUXEON CoB 1321 | 2200K | 60 | 10961 | 12179 | 155 | 2100 | 29 | D | L2C5-22601321F2900 |
| | 3000K | 70 | 10736 | 11929 | 151 | 2100 | 29 | D | L2C5-30701321E2900 |
| | 4000K | 70 | 11867 | 13185 | 167 | 2100 | 29 | D | L2C5-40701321F2900 |
| | | 70 | 11416 | 12684 | 161 | 2100 | 29 | D | L2C5-40701321E2900 |
| | 5000K | 70 | 11986 | 13318 | 169 | 2100 | 29 | D | L2C5-50701321F2900 |
| | | 70 | 11416 | 12684 | 161 | 2100 | 29 | D | L2C5-50701321E2900 |
| | 5700K | 70 | 11121 | 12357 | 157 | 2100 | 29 | D | L2C5-57701321E2900 |
| | 6500K | 70 | 10834 | 12038 | 153 | 2100 | 29 | D | L2C5-65701321E2900 |
| | 2700K | 80 | 10286 | 11429 | 145 | 2100 | 29 | E | L2C5-27801321F2900 |
| | | 80 | 9797 | 10885 | 138 | 2100 | 29 | E | L2C5-27801321E2900 |
| | 3000K | 80 | 10737 | 11930 | 151 | 2100 | 29 | D | L2C5-30801321F2900 |
| | | 80 | 10035 | 11150 | 142 | 2100 | 29 | E | L2C5-30801321E2900 |
| | 3500K | 80 | 10238 | 11376 | 144 | 2100 | 29 | E | L2C5-35801321E2900 |
| | 4000K | 80 | 11352 | 12613 | 160 | 2100 | 29 | D | L2C5-40801321F2900 |
| | | 80 | 10609 | 11788 | 150 | 2100 | 29 | D | L2C5-40801321E2900 |
| | 5000K | 80 | 10609 | 11788 | 150 | 2100 | 29 | D | L2C5-50801321E2900 |
| | 2700K | 90 | 8136 | 9040 | 115 | 2100 | 29 | F | L2C5-27901321E2900 |
| | 3000K | 90 | 8410 | 9344 | 119 | 2100 | 29 | F | L2C5-30901321E2900 |
| 5600K | 90 | 9117 | 10130 | 129 | 2100 | 29 | E | L2C5-56901321E2900 | |
| LUXEON CoB 1825 | 2200K | 60 | 15876 | 17640 | 156 | 2250 | 32 | D | L2C5-22601825F3200 |
| | | 60 | 15120 | 16800 | 144 | 2250 | 32 | E | L2C5-22601825G3200 |
| | 3000K | 70 | 15550 | 17278 | 149 | 2250 | 32 | D | L2C5-30701825G3200 |
| | 4000K | 70 | 17362 | 19291 | 170 | 2250 | 32 | D | L2C5-40701825F3200 |
| | | 70 | 16535 | 18372 | 158 | 2250 | 32 | D | L2C5-40701825G3200 |
| | 5000K | 70 | 18315 | 20350 | 179 | 2250 | 32 | C | L2C5-50701825F3200 |
| | | 70 | 16535 | 18372 | 158 | 2250 | 32 | D | L2C5-50701825G3200 |
| | 5700K | 70 | 16108 | 17898 | 154 | 2250 | 32 | D | L2C5-57701825G3200 |
| | 6500K | 70 | 15692 | 17436 | 150 | 2250 | 32 | D | L2C5-65701825G3200 |
| | 2700K | 80 | 14190 | 15767 | 136 | 2250 | 32 | E | L2C5-27801825G3200 |
| | 3000K | 80 | 15553 | 17281 | 152 | 2250 | 32 | D | L2C5-30801825F3200 |
| | | 80 | 14535 | 16150 | 139 | 2250 | 32 | E | L2C5-30801825G3200 |

Table 1 continued on next page. Notes:

1. Lumileds maintains a tolerance of ±2 on CRI and ±6.5% on luminous flux measurements.
2. Typical CRI is approximately 2 points higher than the minimum CRI specified, but this is not guaranteed.
3. R9 value of 90CRI products is >50.
4. Light Emitting Surface (LES) is the inner diameter (phosphor area) inside the dam.
5. Energy efficiency class as specified in Commission Delegated Regulation (EU) 2019/2015. The available range of energy efficiency classes is A-G.
6. Exception: Not available in EU or UK.

Table 1. Product performance of LUXEON CoB Core Range at specified test current, T_j=85°C (continued).

| PRODUCT | NOMINAL CCT | MINIMUM CRI ^[1, 2, 3] | LUMINOUS FLUX ^[1] (lm) | | TYPICAL LUMINOUS EFFICACY (lm/W) | TEST CURRENT (mA) | LES ^[4] (mm) | ENERGY EFFICIENCY CLASS ^[5] | PART NUMBER |
|-----------------|-------------|----------------------------------|-----------------------------------|---------|----------------------------------|-------------------|-------------------------|--|--------------------|
| | | | MINIMUM | TYPICAL | | | | | |
| LUXEON CoB 1825 | 3500K | 80 | 15930 | 17700 | 156 | 2250 | 32 | D | L2C5-35801825F3200 |
| | | 80 | 14829 | 16477 | 142 | 2250 | 32 | E | L2C5-35801825G3200 |
| | 4000K | 80 | 16443 | 18270 | 161 | 2250 | 32 | D | L2C5-40801825F3200 |
| | | 80 | 15368 | 17075 | 147 | 2250 | 32 | D | L2C5-40801825G3200 |
| | 5000K | 80 | 16799 | 18666 | 165 | 2250 | 32 | D | L2C5-50801825F3200 |
| | | 80 | 15368 | 17075 | 147 | 2250 | 32 | D | L2C5-50801825G3200 |
| | 5600K | 80 | 16556 | 18395 | 162 | 2250 | 32 | D | L2C5-56801825F3200 |
| | 2700K | 90 | 11785 | 13094 | 113 | 2250 | 32 | F | L2C5-27901825G3200 |
| | 3000K | 90 | 13725 | 15250 | 134 | 2250 | 32 | E | L2C5-30901825F3200 |
| | | 90 | 12181 | 13534 | 116 | 2250 | 32 | F | L2C5-30901825G3200 |
| | 3500K | 90 | 14598 | 16220 | 143 | 2250 | 32 | E | L2C5-35901825F3200 |
| | 4000K | 90 | 14841 | 16490 | 145 | 2250 | 32 | E | L2C5-40901825F3200 |
| | 5600K | 90 | 13770 | 15300 | 135 | 2250 | 32 | E | L2C5-56901825F3200 |
| | | 90 | 13206 | 14673 | 126 | 2250 | 32 | E | L2C5-56901825G3200 |

Notes for Table 1:

1. Lumileds maintains a tolerance of ±2 on CRI and ±6.5% on luminous flux measurements.
2. Typical CRI is approximately 2 points higher than the minimum CRI specified, but this is not guaranteed.
3. R9 value of 90CRI products is >50.
4. Light Emitting Surface (LES) is the inner diameter (phosphor area) inside the dam.
5. Energy efficiency class as specified in Commission Delegated Regulation (EU) 2019/2015. The available range of energy efficiency classes is A-G.
6. Exception: Not available in EU or UK.

Optical Characteristics

Table 2. Optical characteristics for LUXEON CoB Core Range at specified test current, T_j=85°C.

| PART NUMBER | TYPICAL TOTAL INCLUDED ANGLE ^[1] | TYPICAL VIEWING ANGLE ^[2] |
|-------------------|---|--------------------------------------|
| L2C5-xxxx12xxxx00 | 135° | 115° |

Notes for Table 2:

1. Total angle at which 90% of total luminous flux is captured.
2. Viewing angle is the off axis angle from the LED centerline where the luminous intensity is ½ of the peak value.

Electrical and Thermal Characteristics

Table 3. Electrical and thermal characteristics for LUXEON CoB Core Range at specified test current, $T_j=85^\circ\text{C}$.

| PART NUMBER | FORWARD VOLTAGE ⁽¹⁾ (V_f) | | | TYPICAL TEMPERATURE COEFFICIENT OF FORWARD VOLTAGE ⁽²⁾ (mV/ $^\circ\text{C}$) | TYPICAL THERMAL RESISTANCE—JUNCTION TO CASE ⁽³⁾ ($^\circ\text{C}/\text{W}$) |
|--------------------|--|---------|---------|---|--|
| | MINIMUM | TYPICAL | MAXIMUM | | |
| L2C5-xxxx1202E0600 | 32.5 | 34.5 | 37.5 | -16 | 0.98 |
| L2C5-xxxx1202E0900 | 32.5 | 34.5 | 37.5 | -16 | 0.98 |
| L2C5-xxxx1203F0900 | 32.5 | 34.2 | 37.5 | -16 | 0.62 |
| L2C5-xxxx1203E0900 | 32.5 | 34.5 | 37.5 | -16 | 0.70 |
| L2C5-xxxx1204F1300 | 32.5 | 34.7 | 37.5 | -16 | 0.46 |
| L2C5-xxxx1204E1300 | 32.5 | 34.8 | 37.5 | -16 | 0.55 |
| L2C5-xxxx1205F1300 | 32.5 | 34.7 | 37.5 | -16 | 0.37 |
| L2C5-xxxx1205E1300 | 32.5 | 35.0 | 37.5 | -16 | 0.51 |
| L2C5-xxxx1208F1500 | 32.5 | 34.7 | 37.5 | -16 | 0.25 |
| L2C5-xxxx1208E1500 | 32.5 | 34.8 | 37.5 | -16 | 0.29 |
| L2C5-xxxx1211F1900 | 32.5 | 34.3 | 37.5 | -16 | 0.18 |
| L2C5-xxxx1211E1900 | 32.5 | 34.8 | 37.5 | -16 | 0.23 |
| L2C5-xxxx1213F2300 | 32.5 | 34.2 | 37.5 | -16 | 0.16 |
| L2C5-xxxx1216F2300 | 32.5 | 34.0 | 37.5 | -16 | 0.13 |
| L2C5-xxxx1216E2300 | 32.5 | 34.5 | 37.5 | -16 | 0.14 |
| L2C5-xxxx1812F2300 | 48.8 | 51.1 | 56.3 | -16 | 0.12 |
| L2C5-xxxx1812G2300 | 48.8 | 51.7 | 56.3 | -16 | 0.12 |
| L2C5-xxxx1321F2900 | 35.2 | 37.5 | 40.6 | -16 | 0.08 |
| L2C5-xxxx1321E2900 | 35.2 | 37.5 | 40.6 | -16 | 0.08 |
| L2C5-xxxx1825F3200 | 48.8 | 50.4 | 56.3 | -16 | 0.05 |
| L2C5-xxxx1825G3200 | 48.8 | 51.7 | 56.3 | -16 | 0.05 |

Notes for Table 3:

1. Lumileds maintains a tolerance of $\pm 2\%$ on forward voltage measurements.
2. Measured between 25°C and 85°C .
3. Thermal resistance is measured between junction and the bottom of the LUXEON CoB substrate.

Absolute Maximum Ratings

Table 4. Absolute maximum ratings for LUXEON CoB Core Range.

| PARAMETER | MAXIMUM PERFORMANCE |
|--|---|
| DC Forward Current ^(1,2) | 2x test current ⁽³⁾ |
| LED Junction Temperature ⁽¹⁾ (DC & Pulse) | 125°C |
| ESD Sensitivity (ANSI/ESDA/JEDEC JS-001-2012) | Class 3B |
| Operating Case Temperature ⁽¹⁾ | -40°C to 105°C |
| LED Storage Temperature | -40°C to 120°C |
| Allowable Reflow Cycles | 3 |
| Reverse Voltage (V_{reverse}) | LUXEON LEDs are not designed to be driven in reverse bias |

Notes for Table 4:

1. Proper current derating must be observed to maintain the junction temperature below the maximum allowable junction temperature.
2. Residual periodic variations due to power conversion from alternating current (AC) to direct current (DC), also called "ripple," are acceptable if the following conditions are met:
 - The frequency of the ripple current is 100Hz or higher
 - The average current for each cycle does not exceed the maximum allowable DC forward current
 - The maximum amplitude of the ripple does not exceed 20% of the maximum allowable DC forward current
3. Exception: LUXEON CoB 1812 has a maximum DC forward current of 2.1A (1.75x test current).

Characteristic Curves

Spectral Power Distribution Characteristics

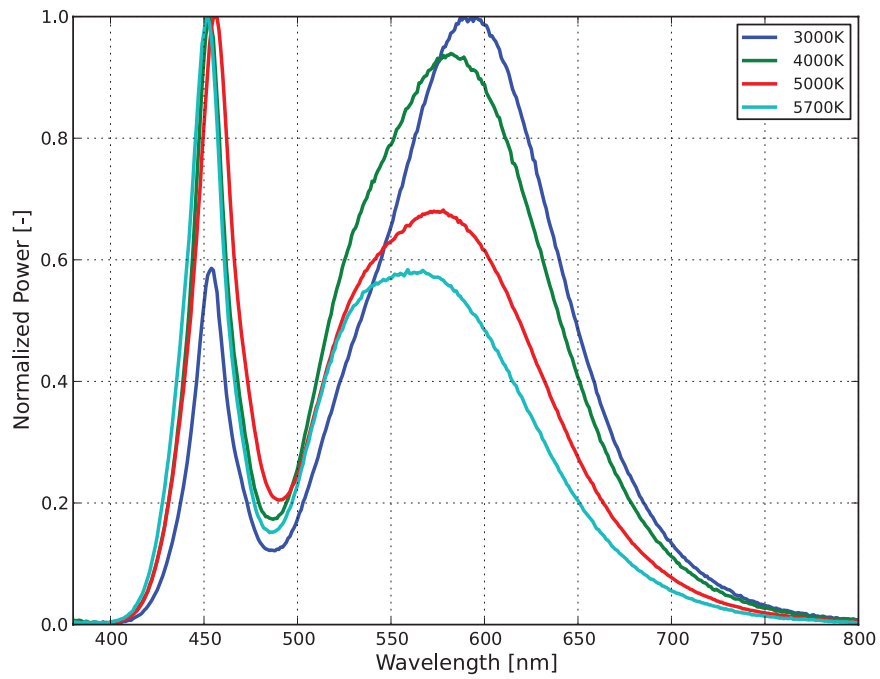

Figure 1a. Typical normalized power vs. wavelength for L2C5-xx7012xxxxx00 at specified test current, $T_j=85^\circ\text{C}$.

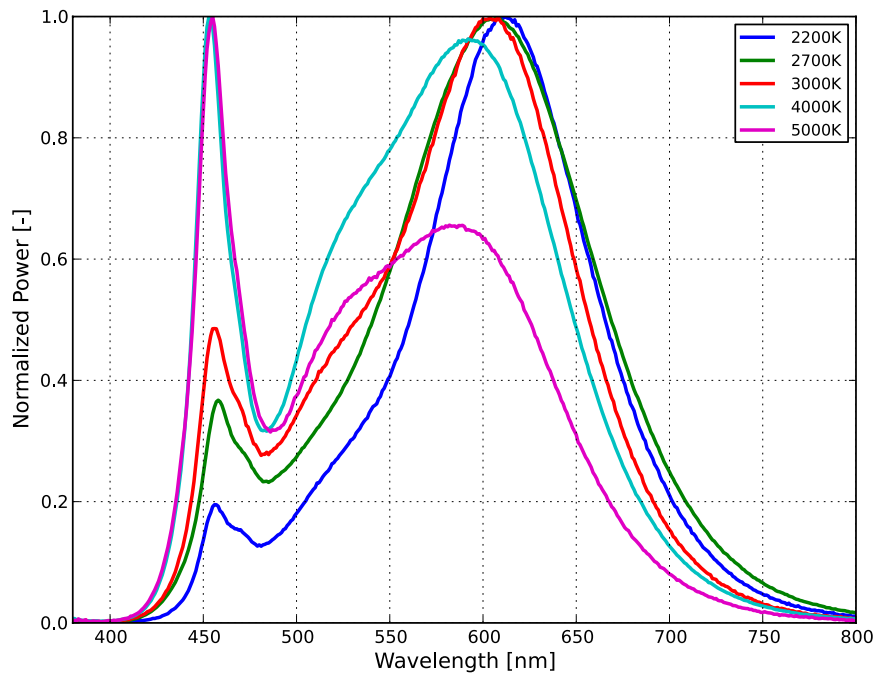

Figure 1b. Typical normalized power vs. wavelength for L2C5-xx8012xxxxx00 at specified test current, $T_j=85^\circ\text{C}$.

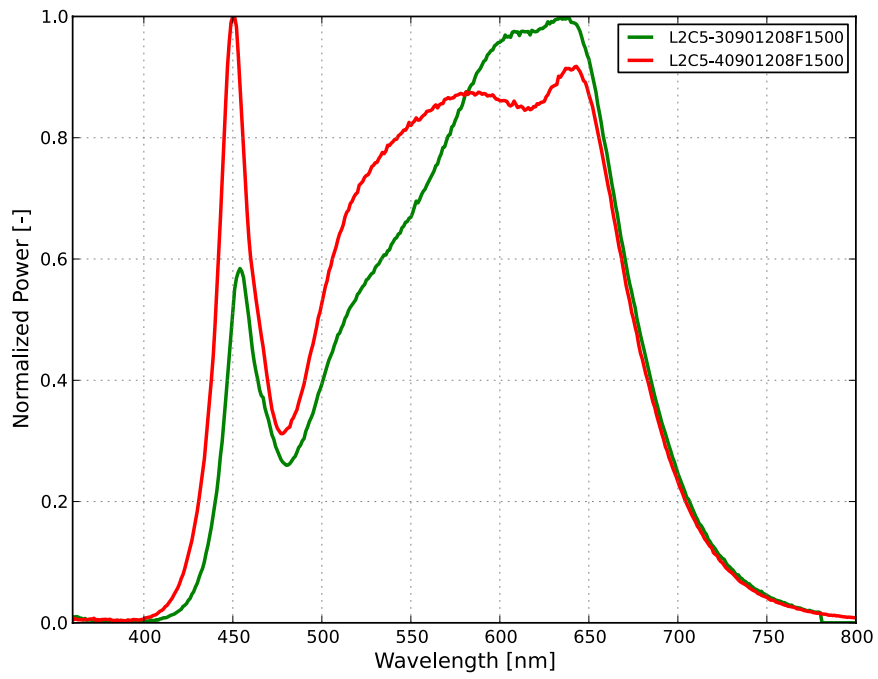

Figure 1c. Typical normalized power vs. wavelength for L2C5-xx9012xxFxx00 at specified test current, $T_j=85^{\circ}\text{C}$.

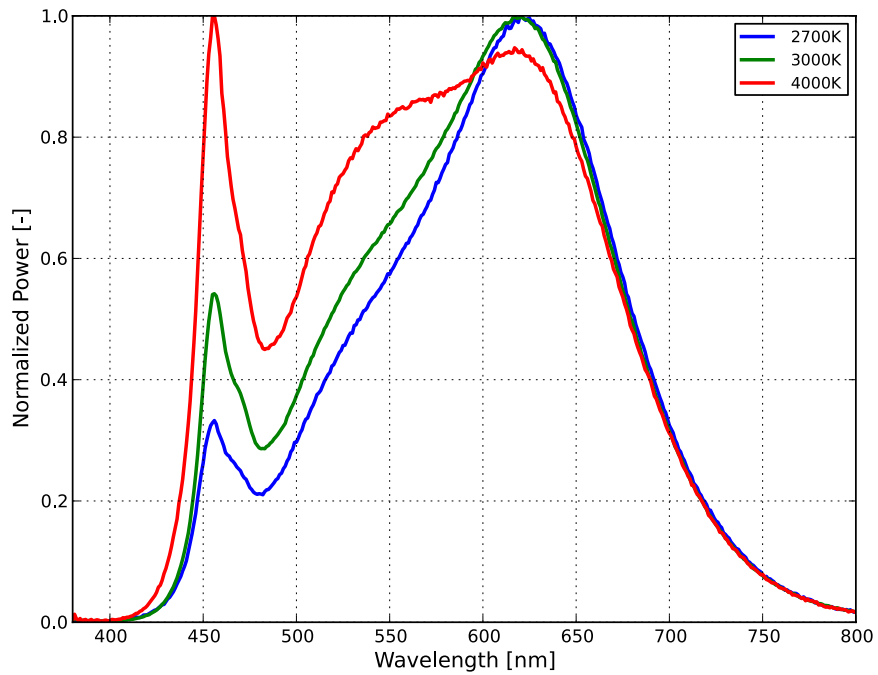

Figure 1d. Typical normalized power vs. wavelength for L2C5-xx9012xxExx00 at specified test current, $T_j=85^{\circ}\text{C}$.

Light Output Characteristics

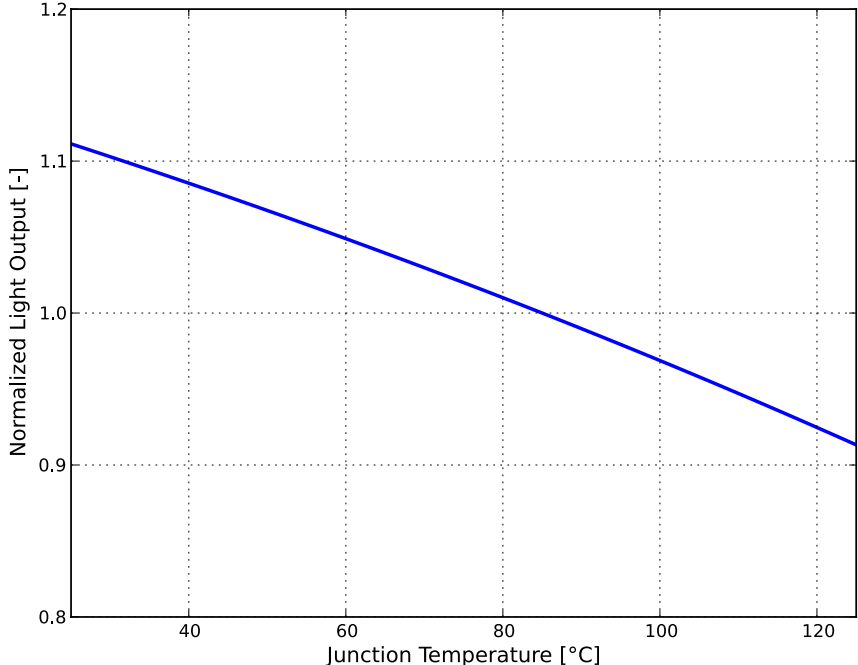

Figure 2. Typical normalized light output vs. junction temperature for L2C5-xxxx12xxxxx00 at specified test current.

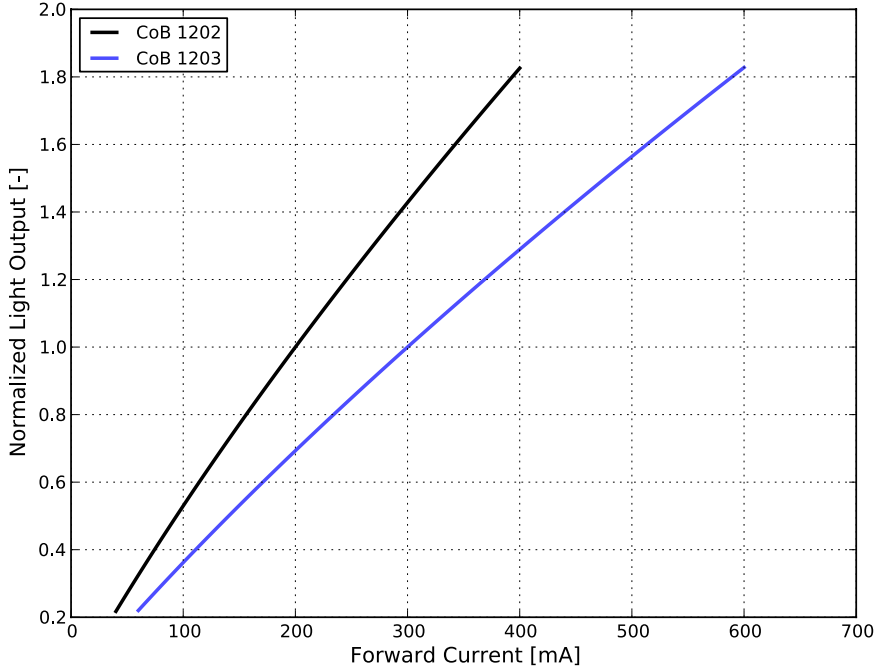

Figure 3a. Typical normalized light output vs. forward current for L2C5-xxxx1202xxx00 and L2C5-xxxx1203xxx00 at $T_j=85^{\circ}\text{C}$.

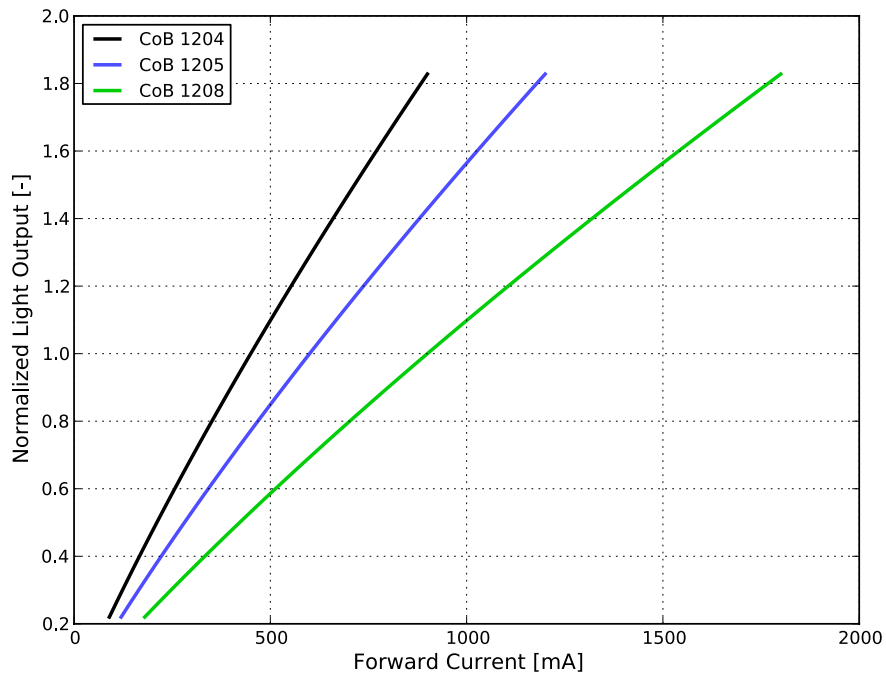

Figure 3b. Typical normalized light output vs. forward current for L2C5-xxxx1204xxx00, L2C5-xxxx1205xxx00 and L2C5-xxxx1208xxx00 at $T_j=85^\circ\text{C}$.

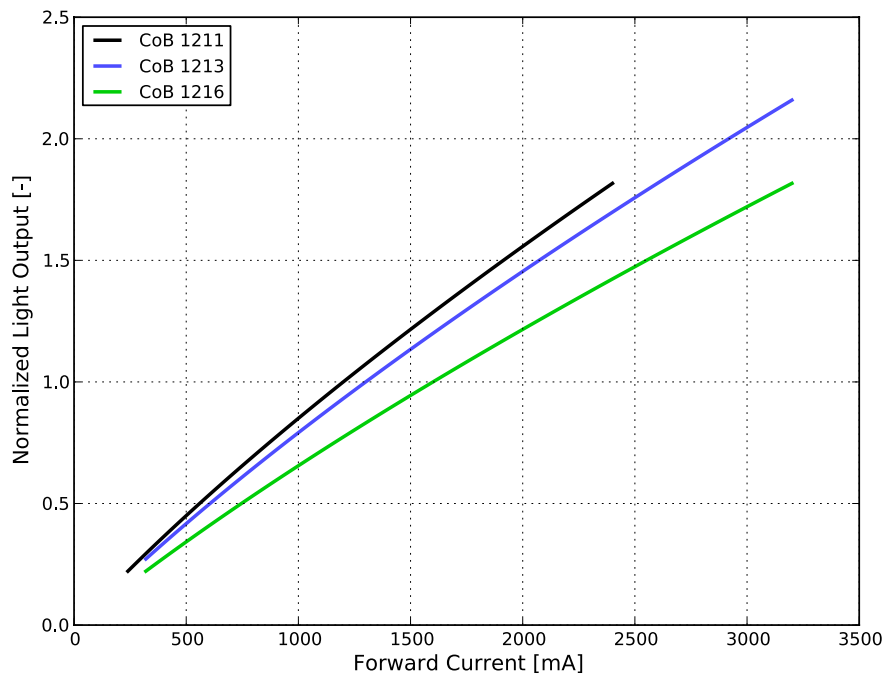

Figure 3c. Typical normalized light output vs. forward current for L2C5-xxxx1211xxx00, L2C5-xxxx1213xxx00 and L2C5-xxxx1216xxx00 at $T_j=85^\circ\text{C}$.

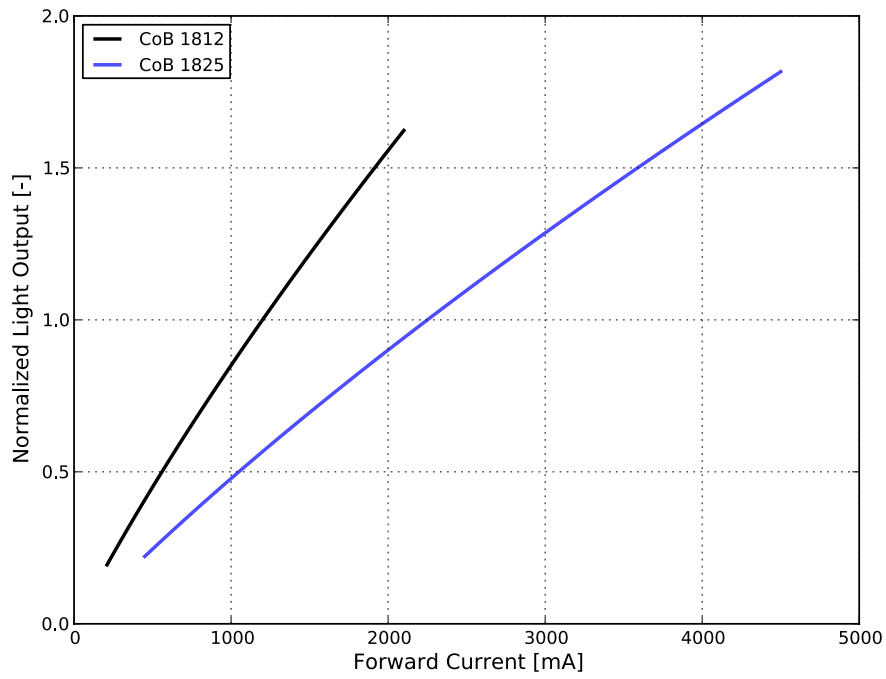

Figure 3d. Typical normalized light output vs. forward current for L2C5-xxxx1812xxx00 and L2C5-xxxx1825xxx00 at $T_j=85^\circ\text{C}$.

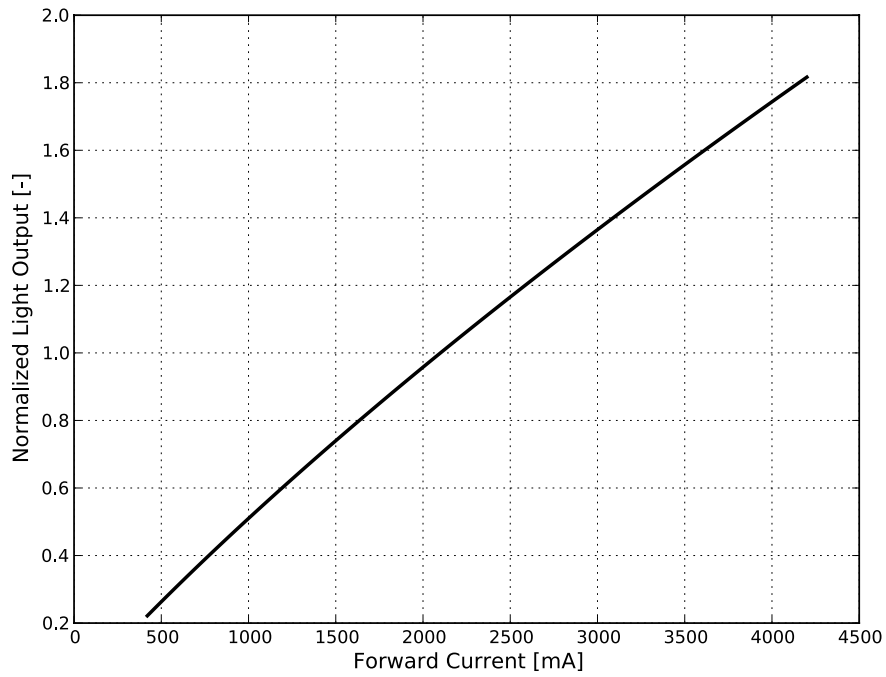

Figure 3e. Typical normalized light output vs. forward current for L2C5-xxxx1321xxx00 at $T_j=85^\circ\text{C}$.

Forward Current Characteristics

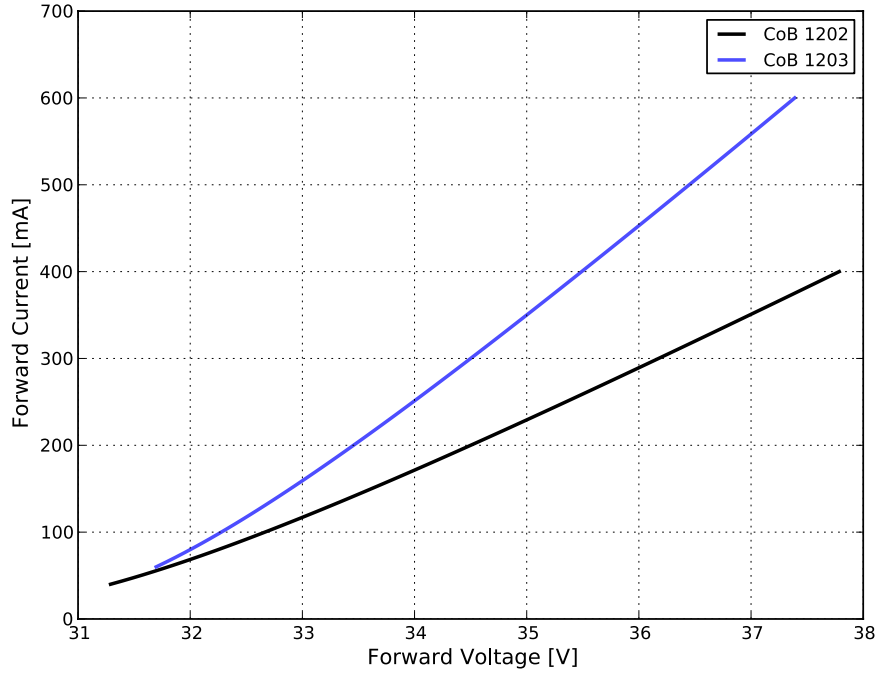

Figure 4a. Typical forward current vs. forward voltage for L2C5-xxxx1202xxx00 and L2C5-xxxx1203xxx00 at $T_j=85^\circ\text{C}$.

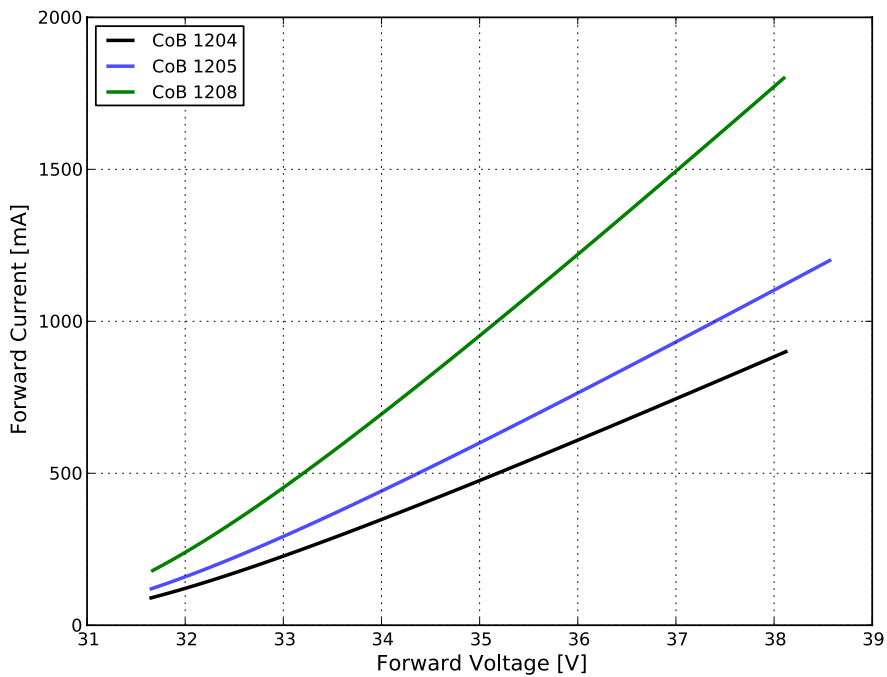

Figure 4b. Typical forward current vs. forward voltage for L2C5-xxxx1204xxx00, L2C5-xxxx1205xxx00 and L2C5-xxxx1208xxx00 at $T_j=85^\circ\text{C}$.

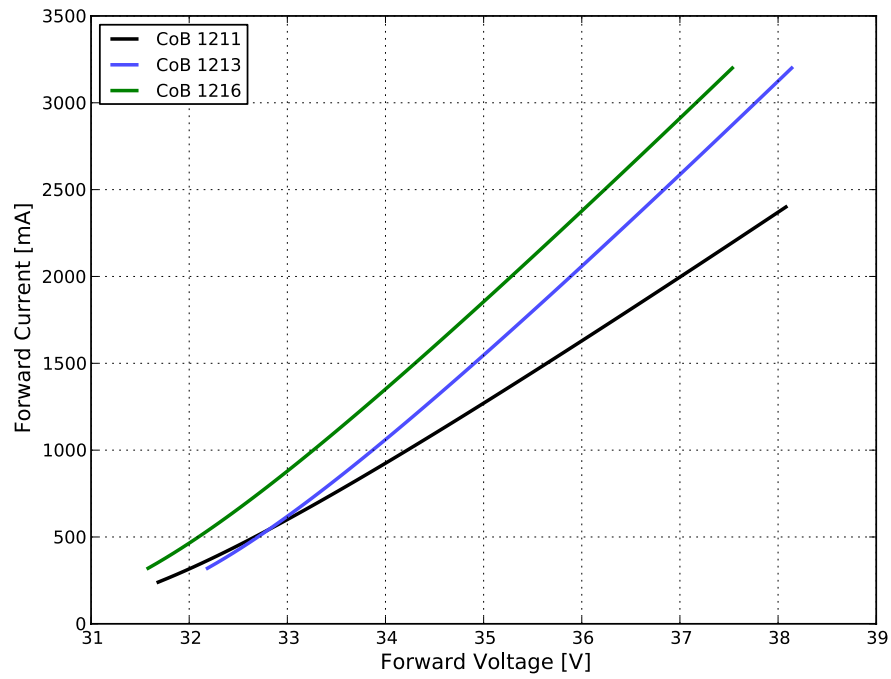

Figure 4c. Typical forward current vs. forward voltage for L2C5-xxxx1211xxx00, L2C5-xxxx1213xxx00 and L2C5-xxxx1216xxx00 at $T_j=85^\circ\text{C}$.

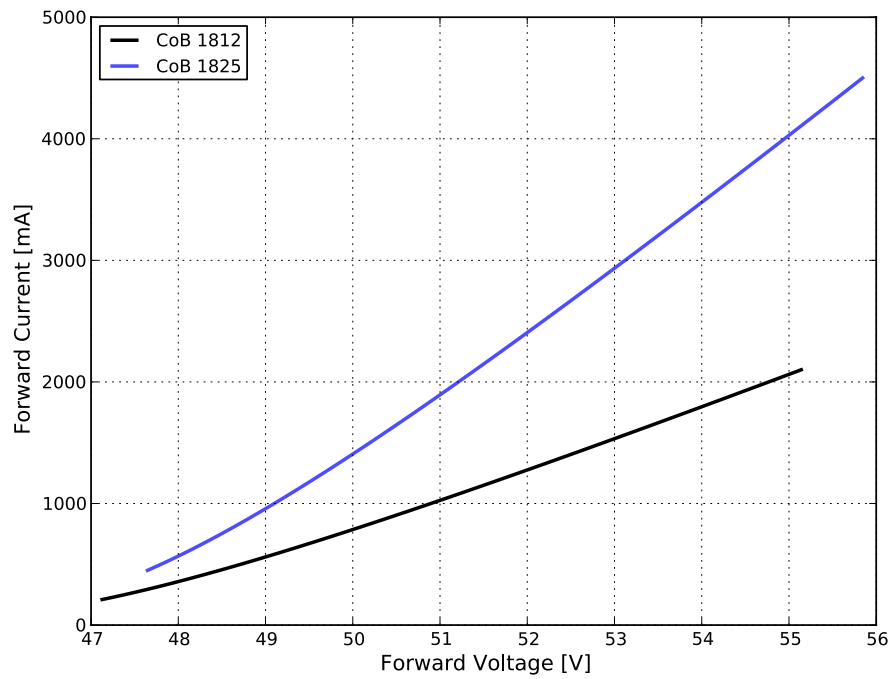

Figure 4d. Typical forward current vs. forward voltage for L2C5-xxxx1812xxx00 and L2C5-xxxx1825xxx00 at $T_j=85^\circ\text{C}$.

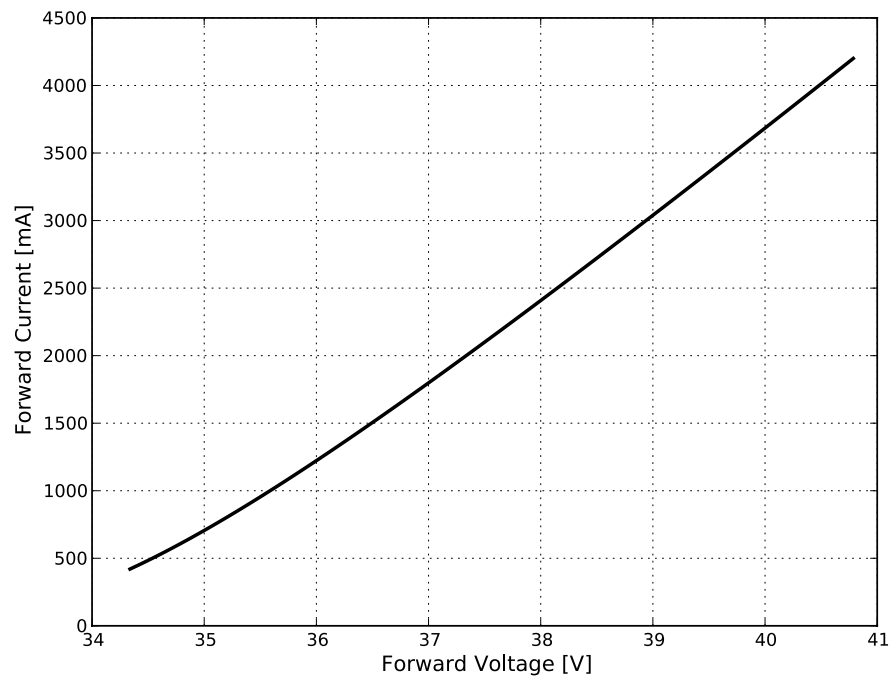

Figure 4e. Typical forward current vs. forward voltage for L2C5-xxxx1321xxx00 at $T_j=85^\circ\text{C}$.

Radiation Pattern Characteristics

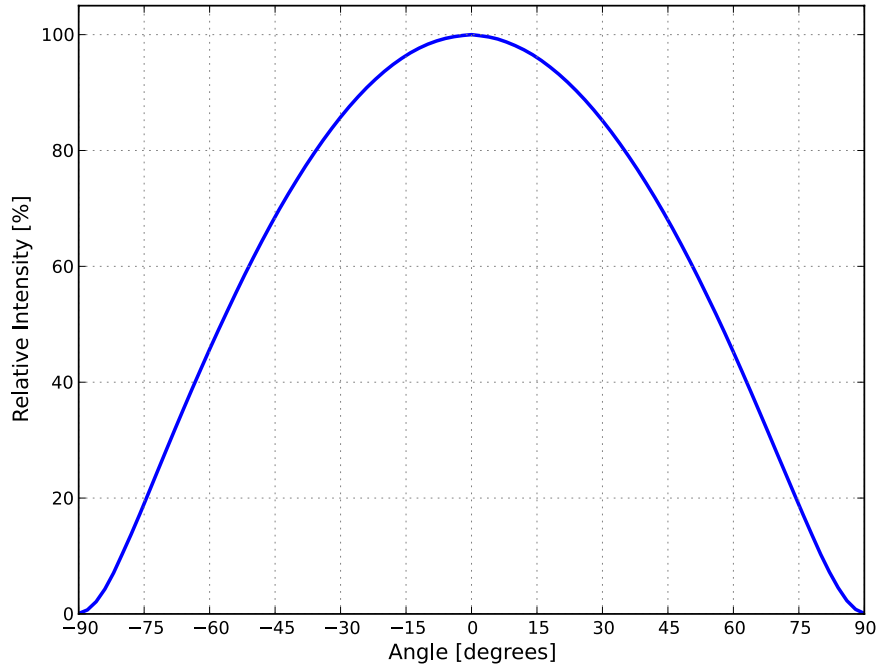

Figure 5. Typical radiation pattern for LUXEON CoB Core Range at specified test current, $T_j=85^{\circ}\text{C}$.

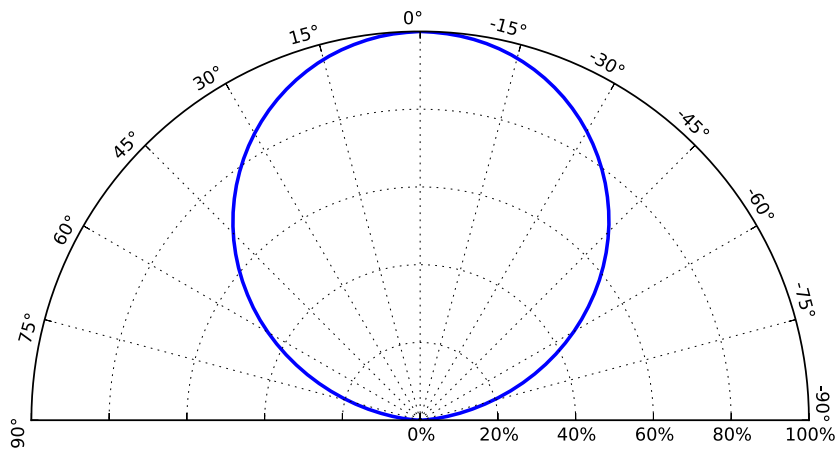

Figure 6. Typical polar radiation pattern for LUXEON CoB Core Range at specified test current, $T_j=85^{\circ}\text{C}$.

Color Bin Definitions

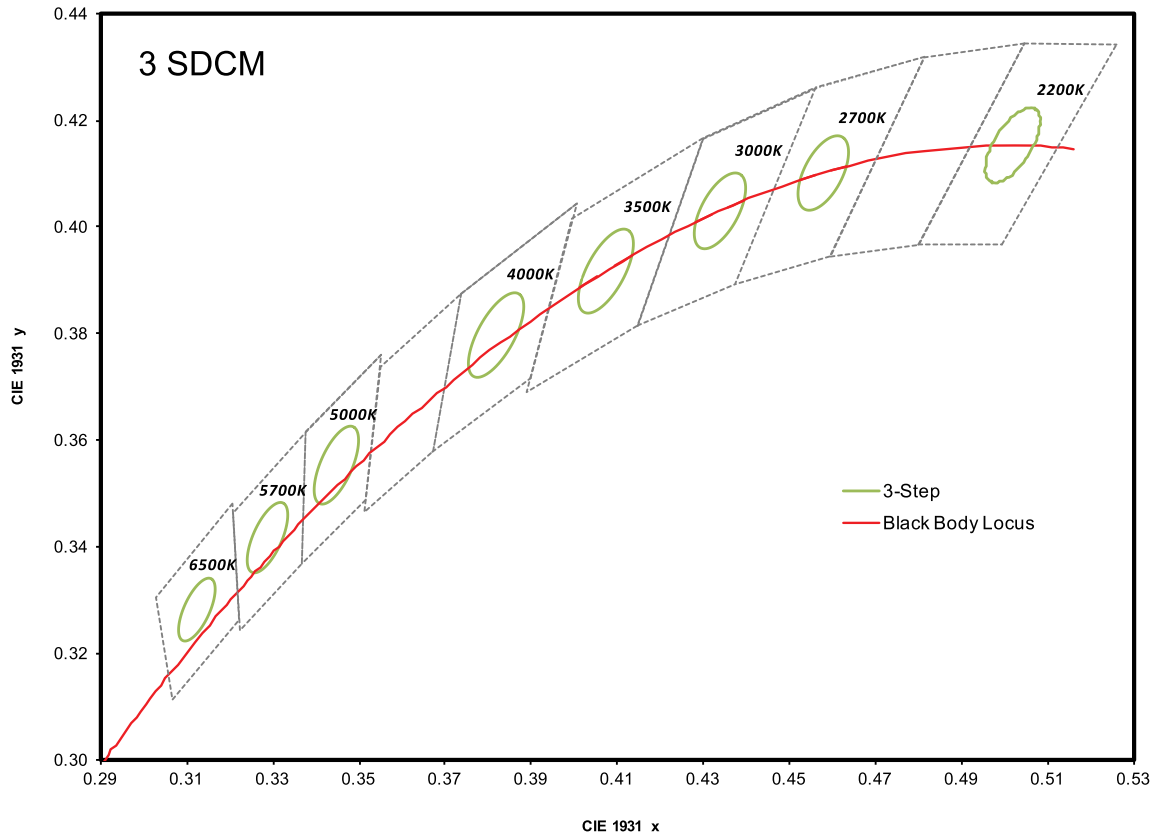

Figure 7. 3-step MacAdam ellipse illustration for Table 5.

Table 5. 3-step MacAdam ellipse color bin definitions for LUXEON CoB Core Range.

| NOMINAL CCT | COLOR SPACE | CENTER POINT ⁽¹⁾ (cx, cy) | MAJOR AXIS, a | MINOR AXIS, b | ELLIPSE ROTATION ANGLE, θ |
|-------------|-------------------------------|---|------------------|------------------|-------------------------------------|
| 2200K | Single 3-step MacAdam ellipse | (0.5020, 0.4155) | 0.00862 | 0.00397 | 49.30° |
| 2700K | Single 3-step MacAdam ellipse | (0.4578, 0.4101) | 0.00810 | 0.00420 | 53.70° |
| 3000K | Single 3-step MacAdam ellipse | (0.4338, 0.4030) | 0.00834 | 0.00408 | 53.20° |
| 3500K | Single 3-step MacAdam ellipse | (0.4073, 0.3917) | 0.00927 | 0.00414 | 54.00° |
| 4000K | Single 3-step MacAdam ellipse | (0.3818, 0.3797) | 0.00939 | 0.00402 | 53.70° |
| 5000K | Single 3-step MacAdam ellipse | (0.3447, 0.3553) | 0.00822 | 0.00354 | 59.60° |
| 5600K | Single 3-step MacAdam ellipse | (0.3293, 0.3423) | 0.00745 | 0.00320 | 59.10° |
| 5700K | Single 3-step MacAdam ellipse | (0.3287, 0.3417) | 0.00745 | 0.00320 | 59.09° |
| 6500K | Single 3-step MacAdam ellipse | (0.3123, 0.3282) | 0.00669 | 0.00285 | 58.57° |

Notes for Table 5:

1. Lumileds maintains a tolerance of ± 0.005 on x and y coordinates in the CIE 1931 color space.

Mechanical Dimensions

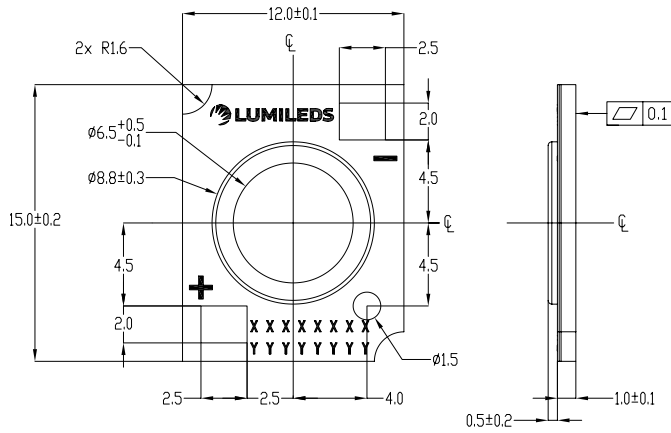

L2C5-xxxx1202x0600

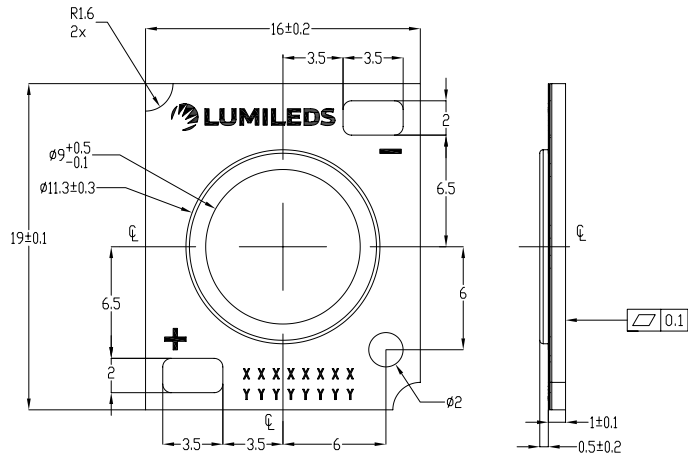

L2C5-xxxx1202x0900, L2C5-xxxx1203x0900

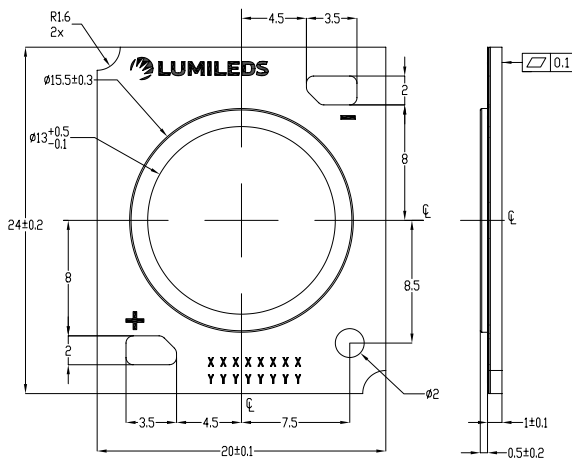

L2C5-xxxx1204x1300, L2C5-xxxx1205x1300

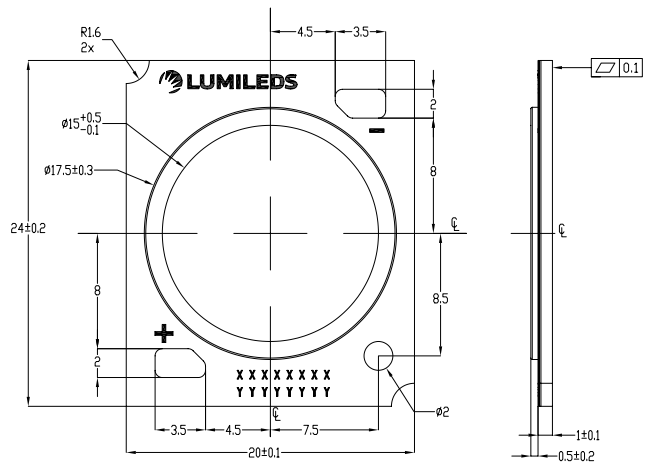

L2C5-xxxx1208x1500

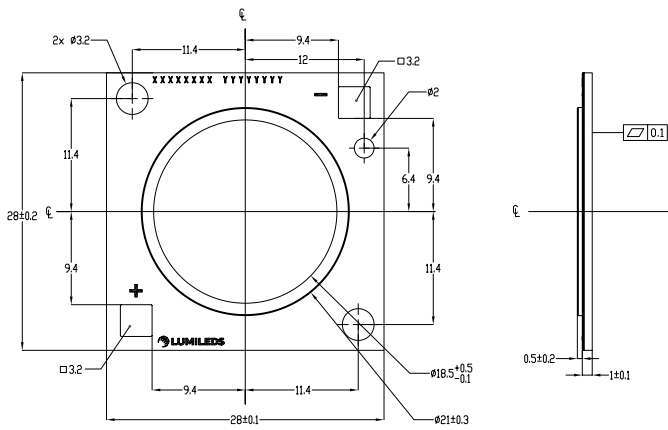

L2C5-xxxx1211x1900

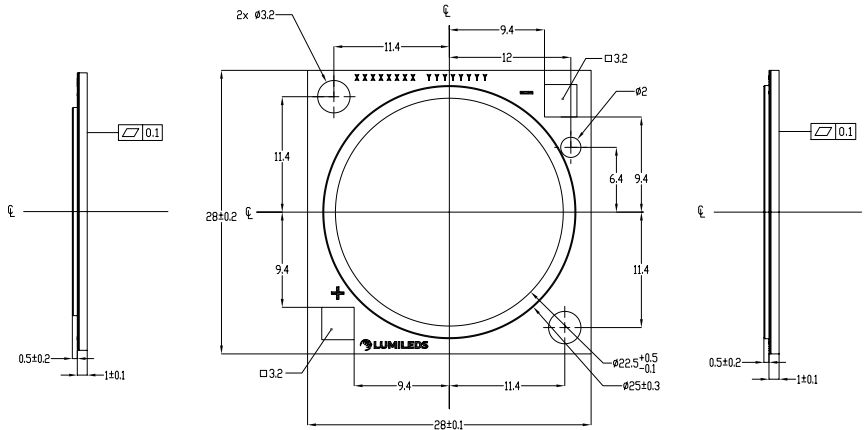

L2C5-xxxx1213x2300, L2C5-xxxx1216x2300
and L2C5-xxxx1812x2300

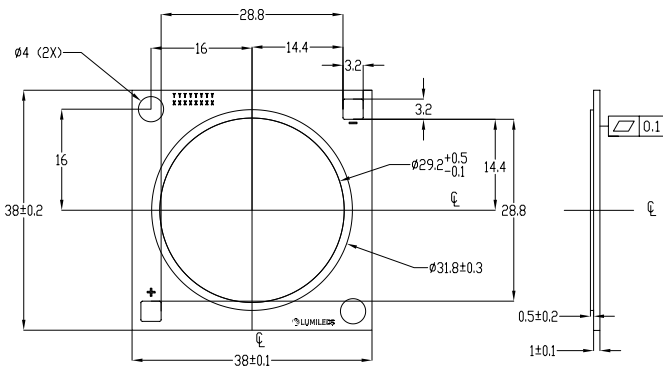

L2C5-xxxx1321x2900

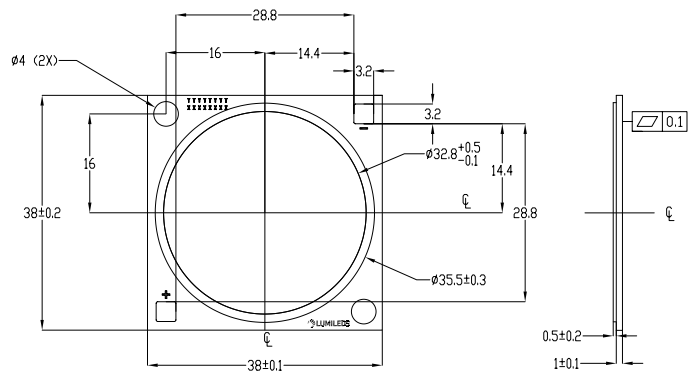

L2C5-xxxx1825x3200

Figure 8. Mechanical dimensions for LUXEON CoB Core Range.

Notes for Figure 8:

1. Drawings not to scale.
2. All dimensions are in millimeters.

Packaging and Labeling Information

LUXEON CoB Core Range LEDs are packaged in tubes then in a carton box. Each tube contains a specified number of LEDs. The LEDs in each tube come from a single category code, ensuring they are all well-matched for light output, color, and forward voltage. Each tube contains a rubber stopper at one end. The tube label has both alphanumeric and bar code information. The carton boxes have printed information providing part numbers with CAT codes that indicate luminous flux, color and forward voltage bins.

Table 6. Number of LEDs per tube for LUXEON CoB Core Range.

| PART NUMBER | TOTAL UNITS PER TUBE | TOTAL TUBES PER INNER BOX | TOTAL UNITS PER INNER BOX |
|--------------------|----------------------|---------------------------|---------------------------|
| L2C5-xxxx1202E0600 | 20 | 5 | 100 |
| L2C5-xxxx1202E0900 | 20 | 5 | 100 |
| L2C5-xxxx1203x0900 | 20 | 5 | 100 |
| L2C5-xxxx1204x1300 | 20 | 5 | 100 |
| L2C5-xxxx1205x1300 | 20 | 5 | 100 |
| L2C5-xxxx1208x1500 | 20 | 5 </td <td>100</td> | 100 |
| L2C5-xxxx1211x1900 | 10 | 5 | 50 |
| L2C5-xxxx1213x2300 | 10 | 5 | 50 |
| L2C5-xxxx1216x2300 | 10 | 5 | 50 |
| L2C5-xxxx1812x2300 | 10 | 5 | 50 |
| L2C5-xxxx1321x2900 | 10 | 5 | 50 |
| L2C5-xxxx1825x3200 | 10 | 5 | 50 |

Tube

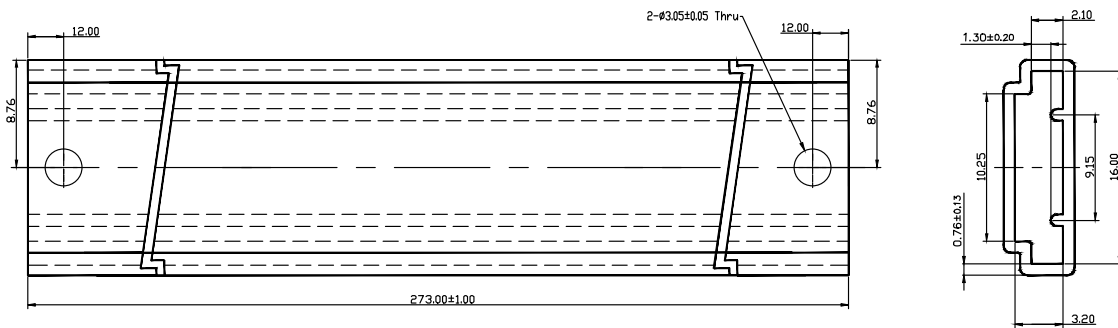

Figure 9a. Tube dimensions for L2C5-xxxx1202E0600.

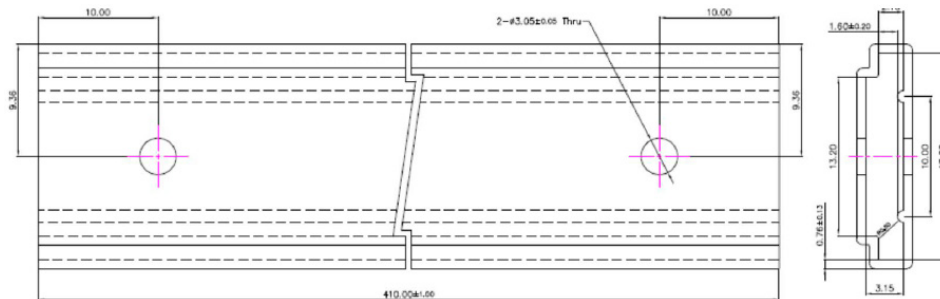

Figure 9b. Tube dimensions for L2C5-xxxx1202E0900.

Notes for Figures 9a and 9b:

1. Drawings not to scale.
2. All dimensions are in millimeters.

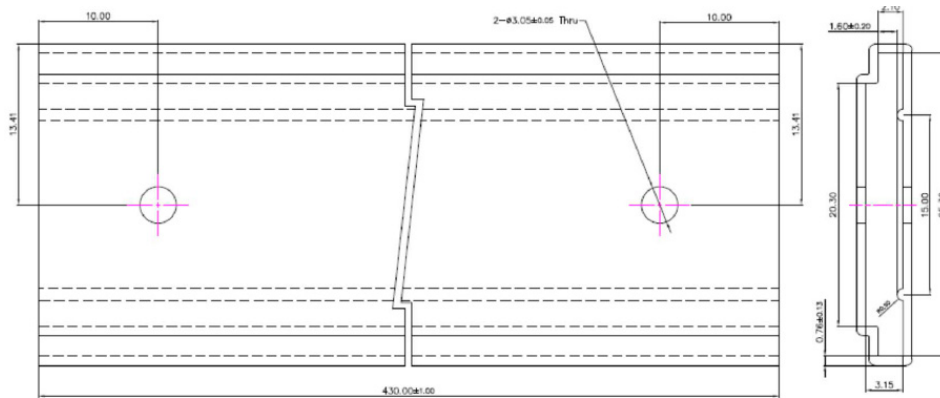

Figure 9c. Tube dimensions for L2C5-xxxx120xx1300 and L2C5-xxxx1208x1500.

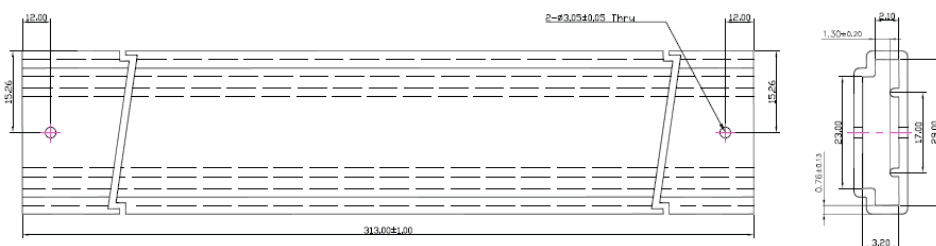

Figure 9d. Tube dimensions for L2C5-xxxx1211x1900, L2C5-xxxx1216x2300 and L2C5-xxxx1812x2300.

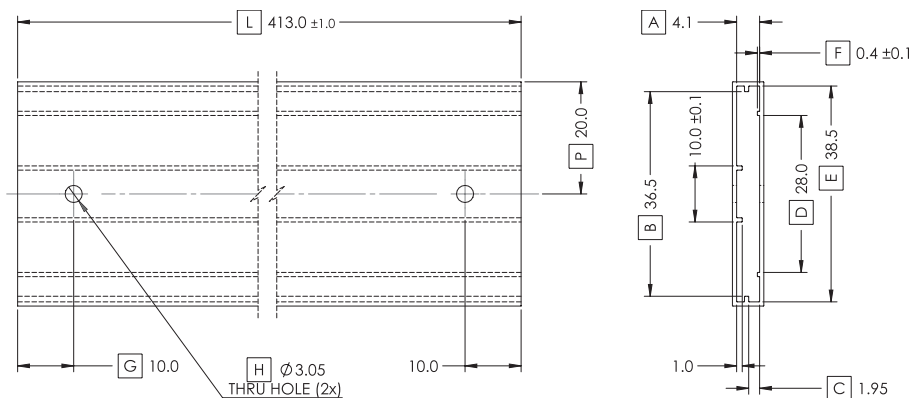

Figure 9e. Tube dimensions for L2C5-xxxx1321x2900 and L2C5-xxxx1825x3200.

Notes for Figures 9c, 9d and 9e:
 1. Drawings not to scale.
 2. All dimensions are in millimeters.

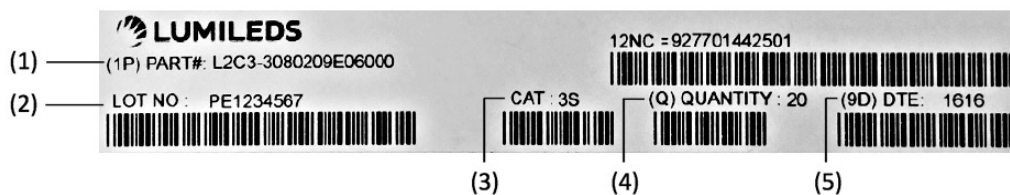

Figure 10. Example of a tube label for LUXEON CoB Core Range.

Notes for Figure 10 - Tube Label descriptions for customer use:
 Field labels not described are for Lumileds internal use only.
 1. Lumileds part number.
 2. Unique production lot identification number. This number is required for traceability purpose.
 3. Product category code.
 4. Number of LED emitters in a tube.
 5. LED test date in YYYY format.

Inner Box

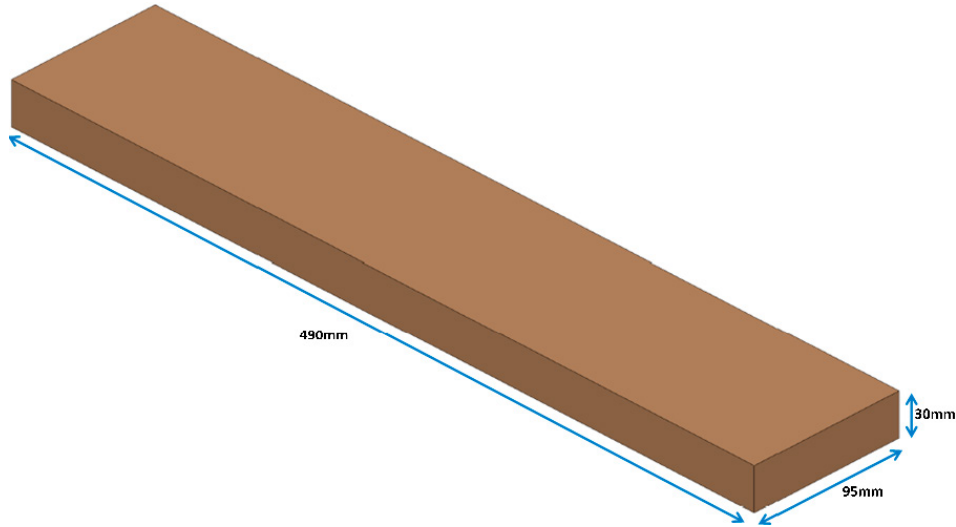

Figure 11. Dimensions for inner box packaging for LUXEON CoB Core Range.

Table 7. Inner box information for LUXEON CoB Core Range.

| BOX TYPE | DIMENSIONS (mm) | | | AVERAGE WEIGHT (100pcs/box) | AVERAGE WEIGHT (50pcs/box) |
|-----------|-----------------|-----|----|--------------------------------|-------------------------------|
| | H | L | W | | |
| Inner Box | 30 | 490 | 95 | 0.340Kg | 0.305Kg |

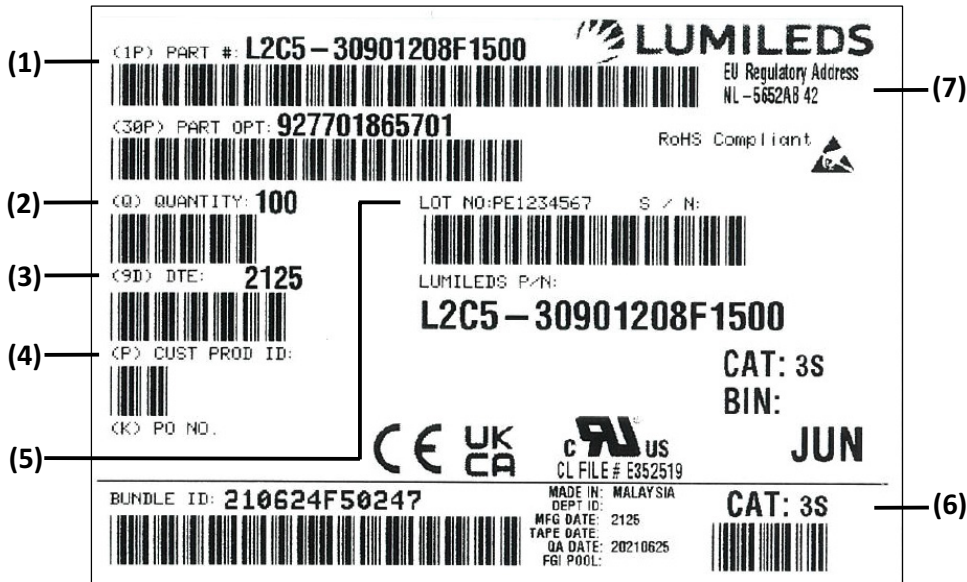

Figure 12. Example of inner box label for LUXEON CoB Core Range.

Notes for Figure 12 – Inner Box Label descriptions for customer use:

Field labels not described are for Lumileds internal use only.

1. Lumileds part number.
2. Number of LED emitters in a box.
3. LED test date in YYYY format.
4. Customer part number for custom requests only.
5. Unique production lot identification number. This number is required for traceability purpose.
6. Product category code.
7. EU regulatory address.

Outer Box

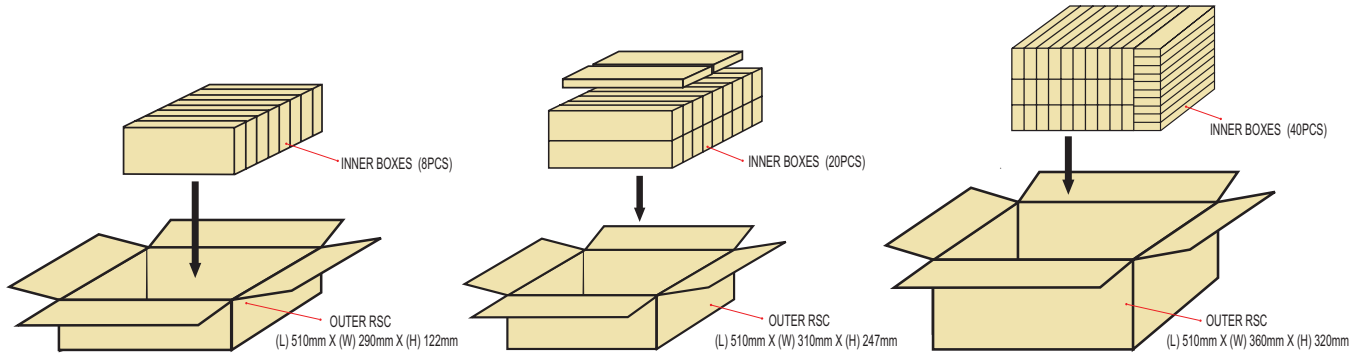

Figure 13. Dimensions for outer box packaging for LUXEON CoB Core Range.

Table 8. Outer box information for LUXEON CoB Core Range.

| BOX TYPE | DIMENSIONS (mm) | | | MAXIMUM INNER BOXES PER OUTER BOX | MAXIMUM QUANTITY PER OUTER BOX | AVERAGE WEIGHT (100pcs/box) | AVERAGE WEIGHT (50pcs/box) |
|--------------|-----------------|-----|-----|-----------------------------------|--------------------------------|-----------------------------|----------------------------|
| | H | L | W | | | | |
| Outer Box 8 | 122 | 510 | 290 | 8 | 800 | 3.05kg | 2.77kg |
| Outer Box 20 | 247 | 510 | 310 | 20 | 2000 | 7.55kg | 6.85kg |
| Outer Box 40 | 320 | 510 | 360 | 40 | 4000 | 15.10kg | 13.70kg |

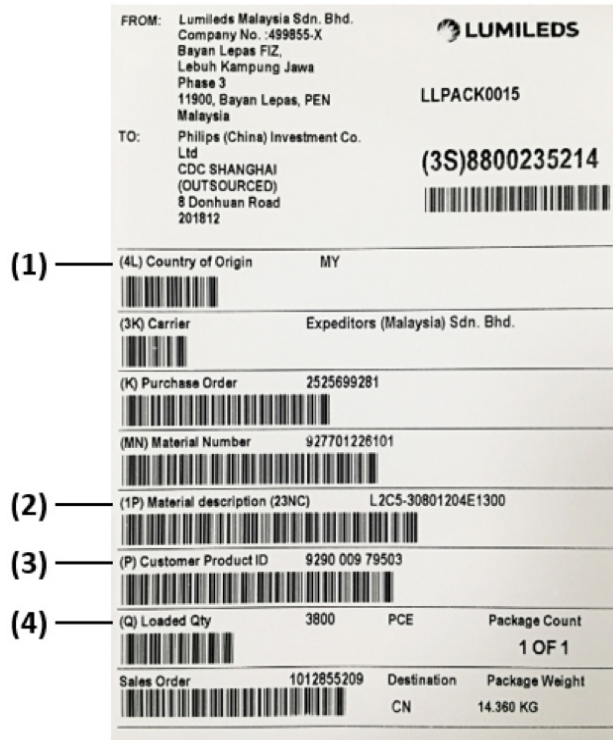

Figure 14. Example of outer box label for LUXEON CoB Core Range.

Notes for Figure 14 – Outer Box Label descriptions for customer use:
Field labels not described are for Lumileds internal use only.

1. Country code of origin of manufacturing of parts (e.g. MY for Malaysia, CN for China) according to ISO 3166-1 alpha-2 document.
2. Lumileds part number.
3. Customer part number for custom requests only.
4. Total number of LED emitters in a shipment box.

About Lumileds

Companies developing automotive, mobile, IoT and illumination lighting applications need a partner who can collaborate with them to push the boundaries of light. With over 100 years of inventions and industry firsts, Lumileds is a global lighting solutions company that helps customers around the world deliver differentiated solutions to gain and maintain a competitive edge. As the inventor of Xenon technology, a pioneer in halogen lighting and the leader in high performance LEDs, Lumileds builds innovation, quality and reliability into its technology, products and every customer engagement. Together with its customers, Lumileds is making the world better, safer, more beautiful—with light.

To learn more about our lighting solutions, visit lumileds.com.



©2021 Lumileds Holding B.V. All rights reserved.
LUXEON is a registered trademark of the Lumileds Holding B.V. in the United States and other countries.

lumileds.com

Neither Lumileds Holding B.V. nor its affiliates shall be liable for any kind of loss of data or any other damages, direct, indirect or consequential, resulting from the use of the provided information and data. Although Lumileds Holding B.V. and/or its affiliates have attempted to provide the most accurate information and data, the materials and services information and data are provided "as is," and neither Lumileds Holding B.V. nor its affiliates warrants or guarantees the contents and correctness of the provided information and data. Lumileds Holding B.V. and its affiliates reserve the right to make changes without notice. You as user agree to this disclaimer and user agreement with the download or use of the provided materials, information and data. A listing of Lumileds product/patent coverage may be accessed at lumileds.com/patents.