

PSR-M-EM1-PROX2-SC - Extension module



1104987

<https://www.phoenixcontact.com/us/products/1104987>

Please be informed that the data shown in this PDF document is generated from our online catalog. Please find the complete data in the user documentation. Our general terms of use for downloads are valid.



Safe extension module for monitoring zero-speed and speed, monitoring of 2 axes, suitable for NPN/PNP proximity switch, TBUS interface, up to SIL 3, Cat. 4/PL e, pluggable screw terminal block, TBUS connector included

Product description

The configurable and individually scalable PSRmodular safety system is a flexible safety solution for monitoring your machine or system. The safe extension module is used to monitor downtimes and speed. The module is suitable for connection of NPN/PNP proximity switches.

Your advantages

- Cost-effective safety solution with a high level of adaptability to individual requirements
- Fast startup, thanks to easy hardware and software configuration
- Machine downtimes minimized with comprehensive, easy-to-understand diagnostics
- Narrow housing width of just 22.6 mm
- Up to Cat. 4/PL e in accordance with EN ISO 13849-1, SIL 3 in accordance with EN IEC 62061, SIL 3 in accordance with IEC 61508
- Suitable for elevator applications in accordance with EN 81-20

Commercial data

Item number	1104987
Packing unit	1 pc
Minimum order quantity	1 pc
Sales key	DN02
Product key	DNA363
GTIN	4055626974781
Weight per piece (including packing)	165.8 g
Weight per piece (excluding packing)	165.8 g
Customs tariff number	85371098
Country of origin	IT

Technical data

Notes

Note on application

Note on application	Only for industrial use
---------------------	-------------------------

Product properties

Product type	Safety device
Application	Over-speed safety relay
	Zero-speed safety relay
Control	1 and 2 channel

Insulation characteristics

Protection class	III
------------------	-----

Times

Response time	see user manual
Restart time	min. 5 s (Boot time)
	max. 10 s (Boot time)

Data management status

Article revision	00
------------------	----

Electrical properties

Maximum power dissipation for nominal condition	2.18 W ($U_B = 28,8$ V, $IN1 = IN2 = 50$ mA)
Nominal operating mode	100% operating factor
Interfaces	DIN rail TBUS for connection to the master module, supplied as standard
	Proximity switches

Air clearances and creepage distances between the power circuits

Rated surge voltage/insulation	Basic insulation 4 kV between 24 V power supply and I/Os to the housing
--------------------------------	---

Supply

Designation	A1/A2
Rated control circuit supply voltage U_S	19.2 V DC ... 28.8 V DC
Rated control circuit supply voltage U_S	24 V DC -20 % / +20 % (provide external protection, typically 200 mA)
Rated control supply current I_S	typ. 35 mA
Power consumption at U_S	typ. 0.84 W
Inrush current	3.5 A ($\Delta t = 1$ ms at U_S)
Filter time	typ. 20 ms (at A1 in the event of voltage dips at U_S)
Protective circuit	Serial protection against polarity reversal
	Suppressor diode

Input data

Measurement

Input name	Proximity switch inputs
	IN1, IN2
Description of the input	NPN / PNP (3- or 4-wire)
Number of inputs	2
Input voltage range "0" signal	0 V DC ... 5 V DC (NPN) 16 V DC ... 28.8 V DC (PNP)
Input voltage range "1" signal	16 V DC ... 28.8 V DC (NPN) 0 V DC ... 5 V DC (PNP)
Input current range "0" signal	< 2 mA (NPN)
Precision	5 % (in reference to the parameterized limit value)
Limit frequency	max. 5 kHz
Max. permissible overall conductor resistance	150 Ω
Protective circuit	Suppressor diode
Current consumption	typ. 13 mA (NPN, at U _S) typ. -13 mA (PNP, at U _S) max. 17 mA (NPN, at 28.8 V DC) max. -15 mA (PNP, at 28.8 V DC)

Output data

Digital: Proximity switch supply (24V/0V)

Short-circuit protection	no
Nominal output voltage range	16.7 V DC ... 26.3 V DC (U _S - 2,5 V)

Connection data

Connection technology

pluggable	yes
-----------	-----

Conductor connection

Connection method	Screw connection
Conductor cross section rigid	0.2 mm ² ... 2.5 mm ²
Conductor cross section flexible	0.2 mm ² ... 2.5 mm ²
Conductor cross-section AWG	24 ... 12
Stripping length	7 mm
Screw thread	M3
Tightening torque	0.5 Nm ... 0.6 Nm

Signaling

Status display	4 x LED (yellow), 1 x LED (green), 2 x LED (orange)
Operating voltage display	1 x green LED
Error indication	2 x LED (red)

PSR-M-EM1-PROX2-SC - Extension module



1104987

<https://www.phoenixcontact.com/us/products/1104987>

Dimensions

Width	22.61 mm
Height	112.58 mm
Depth	113.6 mm

Material specifications

Color (Housing)	yellow (RAL 1018)
Housing material	Polyamide PA non-reinforced

Characteristics

Safety data: EN ISO 13849

Category	3
Performance level (PL)	e

Safety data: IEC 61508 - High demand

Safety Integrity Level (SIL)	3
------------------------------	---

Safety data: EN IEC 62061

Safety Integrity Level (SIL)	3
------------------------------	---

Environmental and real-life conditions

Ambient conditions

Degree of protection	IP20
Min. degree of protection of inst. location	IP54
Ambient temperature (operation)	-10 °C ... 55 °C (observe derating)
Ambient temperature (storage/transport)	-20 °C ... 85 °C
Maximum altitude	≤ 2000 m (Above sea level)
Max. permissible humidity (storage/transport)	95 % (non-condensing)
Max. permissible relative humidity (operation)	95 % (non-condensing)
Shock	10g for $\Delta t = 16$ ms (continuous shock, 1000 shocks in each space direction)
Vibration (operation)	10 Hz ... 150 Hz, 2g

Approvals

CE

Identification	CE-compliant
----------------	--------------

Mounting

Mounting type	DIN rail mounting
Assembly note	Observe derating
Mounting position	vertical or horizontal

PSR-M-EM1-PROX2-SC - Extension module



1104987

<https://www.phoenixcontact.com/us/products/1104987>

Drawings

Application drawing

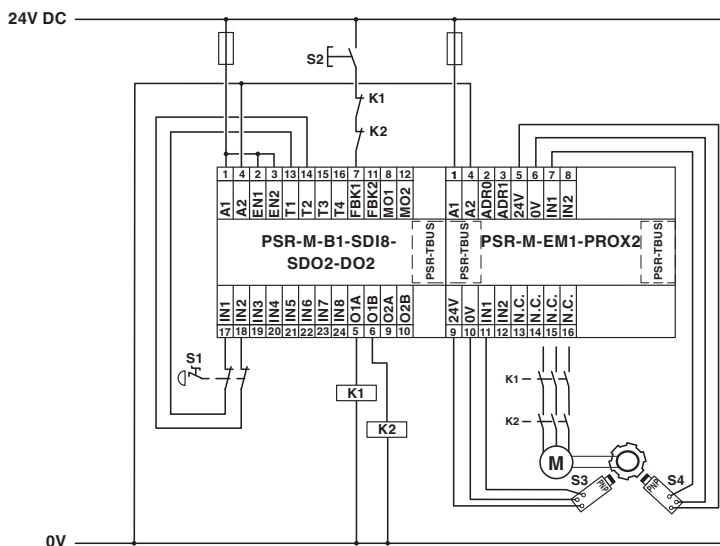

Example application

Block diagram

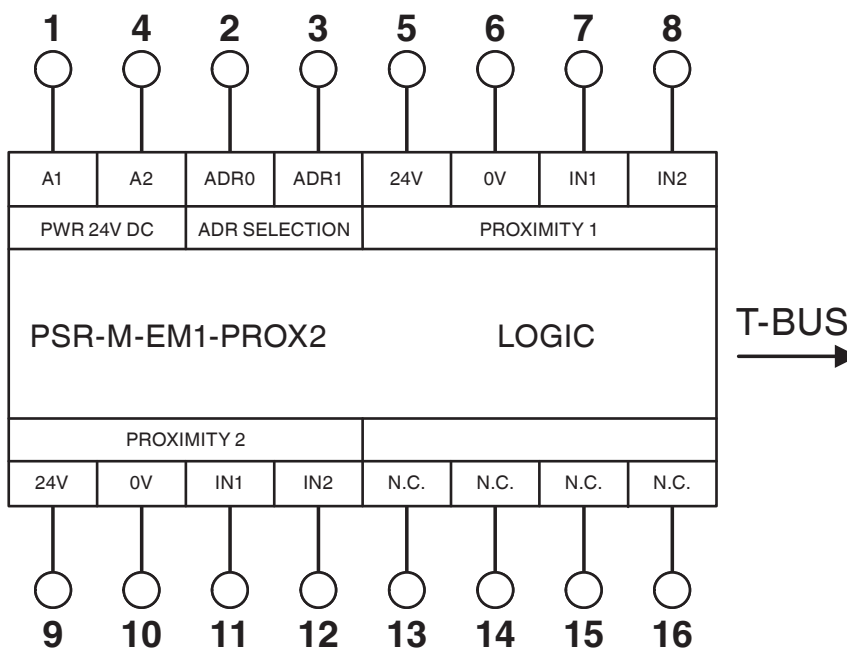

Block diagram

PSR-M-EM1-PROX2-SC - Extension module



1104987

<https://www.phoenixcontact.com/us/products/1104987>

Approvals

To download certificates, visit the product detail page: <https://www.phoenixcontact.com/us/products/1104987>



Functional Safety

Approval ID: Z10 029429 0013



cULus Listed

Approval ID: E238705

cULus Listed

PSR-M-EM1-PROX2-SC - Extension module



1104987

<https://www.phoenixcontact.com/us/products/1104987>

Classifications

ECLASS

ECLASS-11.0	27371819
ECLASS-13.0	27371819
ECLASS-12.0	27371819

ETIM

ETIM 9.0	EC001449
----------	----------

UNSPSC

UNSPSC 21.0	39122200
-------------	----------

PSR-M-EM1-PROX2-SC - Extension module



1104987

<https://www.phoenixcontact.com/us/products/1104987>

Environmental product compliance

EU RoHS

Fulfills EU RoHS substance requirements	Yes, No exemptions
---	--------------------

China RoHS

Environment friendly use period (EFUP)	EFUP-E
	No hazardous substances above the limits

EU REACH SVHC

REACH candidate substance (CAS No.)	No substance above 0.1 wt%
-------------------------------------	----------------------------

Phoenix Contact 2024 © - all rights reserved
<https://www.phoenixcontact.com>

Phoenix Contact USA
586 Fulling Mill Road
Middletown, PA 17057, United States
(+717) 944-1300
info@phoenixcon.com