

280-086 pin connectors with standard M24308 type mounting flange, integral banding platform and crimp termination

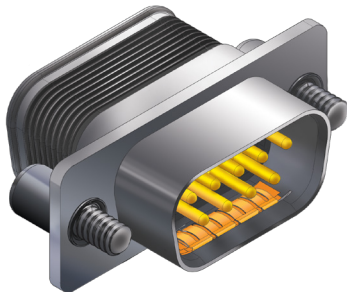

HiPer-D® pin connectors feature integrated banding platform, crimp, rear-releaseable size #20 or #22 contacts. Intermateable with standard M24308-type D-Subminiature connectors, the HiPer-D® features a rugged machined aluminum shell, waterproof sealing and optional ground springs for improved resistance to electromagnetic interference. Gold-plated size #20 contacts conform to M39029/64-369 and accept #20 to #24 AWG wire. Gold-plated size #22 contacts conform to M39029/58-360 and accept #22 to #28 AWG wire. Contacts are packaged with connector. Terminate contacts with crimp tools purchased separately. Glass-reinforced thermoset epoxy insulators, copper alloy retention clips. Fluorosilicone face seal and rear grommet meet IP67 immersion requirement. 1000 VAC, 5 Amps (#22) or 7.5 Amps (#20).

B

Ordering Information							
<b>Sample Part Number</b>			<b>280-086P</b>	<b>3S25</b>	<b>ME</b>	<b>G</b>	<b>P</b>
<b>Basic Part Number</b>	<b>280-086P</b>						
<b>Shell Size-Contact Arrangement</b>	See Shell Size - Contact Arrangements Table						
<b>Shell Finish</b>	<b>ME</b> = Electroless Nickel <b>Z1</b> = Passivated Stainless Steel		<b>MT</b> = Nickel-PTFE <b>ZM</b> = Nickel over Stainless				
<b>Ground Spring</b>	<b>G</b> = Supplied with EMI Ground Spring		<b>N</b> = No Ground Spring				
<b>Mating Hardware</b>	<b>N</b> = No Hardware (Through-Hole) <b>L</b> = Jackscrew, Hex Head, Low Profile <b>S</b> = Screwlock, Male, Hex Head, Low Profile		<b>P</b> = #4-40 Female Jackpost <b>K</b> = Jackscrew, Slot Head, Extended Length <b>T</b> = Screwlock, Male, Slot Head, Extended Length				

Shell Size - Contact Arrangements		
Shell Size-Contact Arr.	Contact Size and Qty	
	#20	#22
<b>Standard Density</b>		
<b>1S9</b>	9	
<b>2S15</b>	15	
<b>3S25</b>	25	
<b>4S37</b>	37	
<b>5S50</b>	50	
<b>High Density</b>		
<b>1H15</b>		15
<b>2H26</b>		26
<b>3H44</b>		44
<b>4H62</b>		62
<b>5H78</b>		78
<b>6H104</b>		104

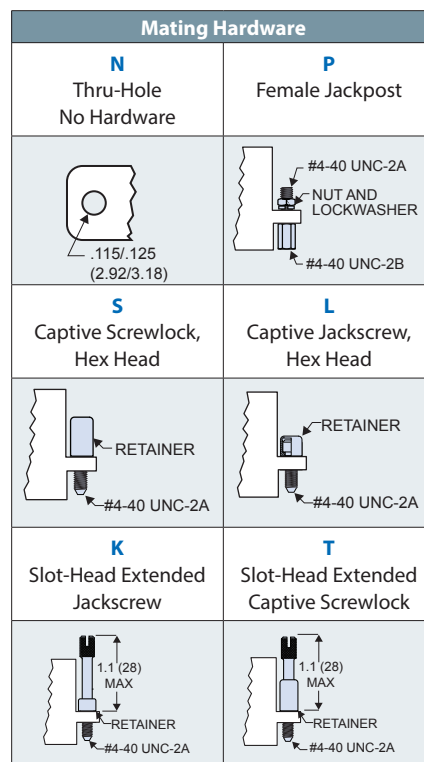

Materials and Finishes	
Shell	Aluminum alloy
Contacts	Copper alloy, 50 microin. gold plated
Insulators	Thermoset epoxy
Retention Clips	Copper alloy
Grommet and Seal	Fluorosilicone rubber
EMI Spring	Copper alloy, nickel plated
Hardware	300 series stainless steel

Specifications	
Current Rating	#22 5 AMPS, #20 7.5 AMPS
Test Voltage	1000 VAC RMS
Insulation Resistance	5000 megohms minimum
Operating Temperature	-65° C. to +200° C.
Ingress Protection	IP 67
Shock	300 g.
Vibration, Random	43.92 g.

280-086 pin connectors with standard M24308 type mounting flange, integral banding platform and crimp termination

## 280-086P DIMENSIONS

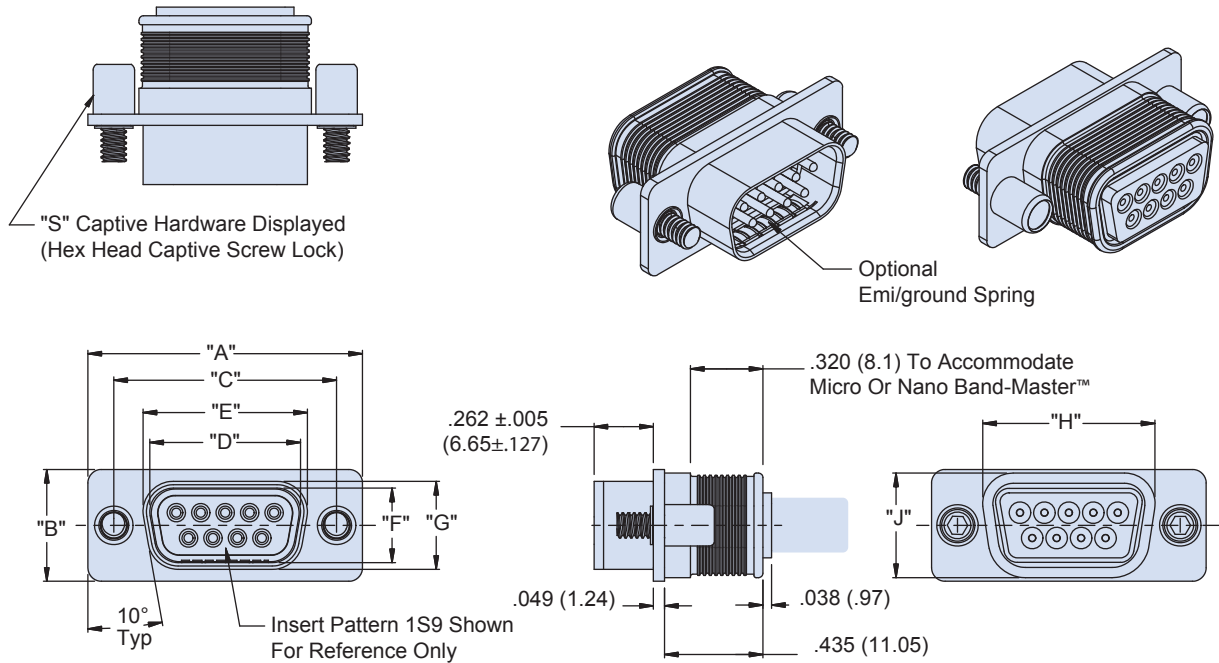

B

Shell Size	Insert Pattern	"A" ±.015		"B" ±.015		"C" ±.005		"D" ±.005		"E" ±.005		"F" ±.005		"G" ±.005		"H"		"J"		Contact P/N
		in.	mm.	in.	mm.	in.	mm.	in.	mm.	in.	mm.	in.	mm.	in.	mm.	in.	mm.	in.	mm.	
1	SD 9	1.213	30.81	0.494	12.55	0.984	24.99	0.666	16.92	0.726	18.44	0.329	8.36	0.389	9.88	0.760	19.30	0.462	11.73	M39029/64-369
	HD 15																			M39029/58-360
2	SD 15	1.541	39.14	0.494	12.55	1.312	33.32	0.994	25.25	1.054	26.77	0.329	8.36	0.389	9.88	1.089	27.66	0.462	11.73	M39029/64-369
	HD 26																			M39029/58-360
3	SD 25	2.088	53.03	0.494	12.55	1.852	47.04	1.534	38.96	1.594	40.49	0.329	8.36	0.389	9.88	1.629	41.38	0.462	11.73	M39029/64-369
	HD 44																			M39029/58-360
4	SD 37	2.729	69.32	0.494	12.55	2.5	63.50	2.182	55.42	2.242	56.95	0.329	8.36	0.389	9.88	2.277	57.84	0.462	11.73	M39029/64-369
	HD 62																			M39029/58-360
5	SD 50	2.635	66.93	0.605	15.37	2.406	61.11	2.079	52.81	2.139	54.33	0.441	11.20	0.501	12.73	2.182	55.42	0.474	12.04	M39029/64-369
	HD 78																			M39029/58-360
6	HD 104	2.729	69.32	0.668	16.97	2.5	63.50	2.212	56.18	2.272	57.71	0.503	12.78	0.563	14.30	2.307	58.60	0.626	15.90	M39029/58-360

## NOTES

- HiPer-D® connectors are available with a wide variety of materials and finishes. See [About Series 28 HiPer-D® Shell Plating Options](#) for additional choices. Glenair offers the industry's widest selection of plating and material choices with no setup charge, no minimum order quantity and no schedule impact.
- For panel cutout dimensions, refer to [Panel Cutouts and Printed Circuit Board Footprints](#).
- Connectors are supplied with crimp contacts per M39029. Contacts are not installed. Refer to [HiPer-D® Contacts and Crimp Tools](#) for contact part numbers, specifications, crimp tool information, and insertion/extraction tools.
- HiPer-D® connectors meet the requirements of MIL-DTL-24308 and are intermateable with standard M24308-type D-Subminiature connectors with corresponding contact arrangements and type.
- Additional electrical, mechanical and environmental specifications are listed in [HiPer-D® Product Specification](#).