

# Application Kit Manual TC3X7

Hardware: Application Kit TC3X7 V2.0

## About this document

### Scope and purpose

The User Manual provide information about using, configuration and connecting the Application Kit with Infineon AURIX™ TC3X7 device.

This Application Kit Hardware Manual familiarizes you with the TriCore Evaluation Board and guides you through the initial configuration of the Application Kit.

### Intended audience

Design, verification, test and software engineers will use this document to get an understanding of the functionality and connections of the Application Kit.

## Table of Contents

	About this document .....	Preface-1
	Table of Contents .....	TOC-2
<b>1</b>	<b>Introduction</b> .....	<b>1-1</b>
<b>2</b>	<b>Features</b> .....	<b>2-1</b>
2.1	Summary of Features .....	2-1
2.2	Block Diagram .....	2-2
2.3	Placement .....	2-3
<b>3</b>	<b>Application Kit Information</b> .....	<b>3-1</b>
3.1	Available Boards .....	3-1
3.2	Power Supply .....	3-1
3.2.1	Power via supply connector (X101) .....	3-1
3.2.2	Power via Micro USB (BU301) .....	3-2
3.2.3	Multi Voltage Safety Micro Processor Supply TLF35584QV .....	3-2
3.3	Real Time Clock .....	3-2
3.4	XGA Display .....	3-3
3.4.1	Write a display register .....	3-3
3.4.2	Read a display register .....	3-3
3.4.3	Touch controller .....	3-4
3.5	Micro SD card .....	3-4
3.6	LEDs .....	3-4
3.7	Clock .....	3-4
3.8	USB Connector .....	3-4
3.8.1	Serial Connection to PC .....	3-5
3.8.2	miniWiggler JDS .....	3-5
3.9	Beeper .....	3-5
3.10	MultiCAN .....	3-5
3.11	LIN .....	3-5
3.12	Ethernet .....	3-5
3.13	Core current measurement .....	3-6
3.14	Other peripherals .....	3-6
3.15	Toggle LED's .....	3-6
3.16	Buttons .....	3-6
3.17	Debug System .....	3-6
3.17.1	OCDS1 .....	3-6
3.17.2	DAP .....	3-6
<b>4</b>	<b>Application Kit Configuration</b> .....	<b>4-1</b>
4.1	Default Pad State .....	4-1
4.2	Bootmode .....	4-1
<b>5</b>	<b>Signal (on board used) Description</b> .....	<b>5-1</b>
5.1	Power Signals .....	5-1
5.2	Reset Signals .....	5-1
5.3	Config Signals .....	5-1
5.4	Clock Signals .....	5-2
5.5	Debug Signals .....	5-2
5.6	Peripheral Signals .....	5-2

## Table of Contents

<b>6</b>	<b>Connector Pin Assignment</b> .....	<b>6-1</b>
6.1	I/O connectors TC387 and TC397 .....	6-1
6.2	Power connector pinout .....	6-1
6.3	USB connector pinout .....	6-2
6.4	CAN connector pinout .....	6-2
6.5	LIN connector pinout .....	6-2
6.6	Ethernet connector pinout .....	6-3
6.7	OCDS1 connector pinout .....	6-3
6.8	DAP connector pinout .....	6-3
<b>7</b>	<b>Schematic and Layout</b> .....	<b>7-1</b>
7.1	Known problems .....	7-1
7.2	Schematic .....	7-1
7.3	Layout .....	7-6
7.4	Layout with Dimensioning .....	7-8

## Introduction

# 1 Introduction

We congratulate you on your purchase of the TriCore Evaluation Board. This kit is a versatile tool, providing quick access to the capabilities of TriCore's powerful architecture.

Applications can be developed easily. The Evaluation Board is equipped with a variety of memories and peripherals for connection to the environment. There is also an interface for the On Chip Debugging Features (OCDS1 and DAP).

The Evaluation Board allows easily the development of TriCore applications with the corresponding tools.

Subsequently, the applications can be downloaded and can be tested with the powerful debugger software.

This Application Kit Hardware Manual familiarizes you with the TriCore Evaluation Board and guides you through the initial configuration of the Application Kit.

For detailed technical information about the TC3X7 (e.g. TC397) please refer to the User Manual of the used device.

## Features

## 2 Features

### 2.1 Summary of Features

- Infineon's TC3X7 (TC397, TC387) AURIX™ 2G Controller in LFBGA-292 Package
- LCD XGA Display 320x240
- SD card slot (mini SD)
- High Speed CAN Transceiver (CAN FD capable)
- USB to UART bridge
- Ethernet Gigabit PHY
- LIN Transceiver
- Crystal 20MHz (default) or External Clock
- USB miniWiggler JDS for easy debugging
- 4 Low Power Status LEDs
- RTC with alarm
- Acoustic beeper
- 100mm x 100mm

### Connectors

The Application Kit TC3X7 offers a wide variety of connectors:

- Standard power connector
- Micro USB connector for ASC Interface (ASC0) and miniWiggler
- RJ45 connector for Ethernet (if Gigabit Ethernet supported by assembled CPU)
- 16-pin header for JTAG interface (OCDS)
- 10-pin header for DAP
- 10pin (2x5) Header for LIN Transceiver (LIN)
- 10pin (2x5) Header for CAN High Speed Transceiver (CAN0)
- two 40-pin connectors with I/O signals
- mini SD card slot

### Components

- Infineon's Multi Voltage Safety Micro Processor Supply TLF35584QV
- LED to validate power supply (5V or 3,3Volt)
- LED indicating RESET (ESR0) active state
- LED indicating activ miniWiggler JDS
- LED switched via DAS software
- Infineon's High Speed CAN Transceiver TLE 9251V (CAN FD capable)
- Infineon's LIN-Transceiver TLE 7259-3GE
- QSPI Real-Time Clock/Calendar with SRAM and unique MAC Id MCP79511 (if CPU not support I2C)
- I2C Real-Time Clock/Calendar with SRAM and unique MAC Id MCP79411 (if CPU support I2C)
- USB to UART bridge FT2232HL (FTDI)
- Integrated 10/100/1000M Ethernet Precision Transceiver RTL8211FI-CG (Realtek)
- Touch screen controller ADS7843
- 4 general purpose LEDs
- Reset switch
- Wake switch
- Xilinx CPLD XC9572XL

Features

2.2 Block Diagram

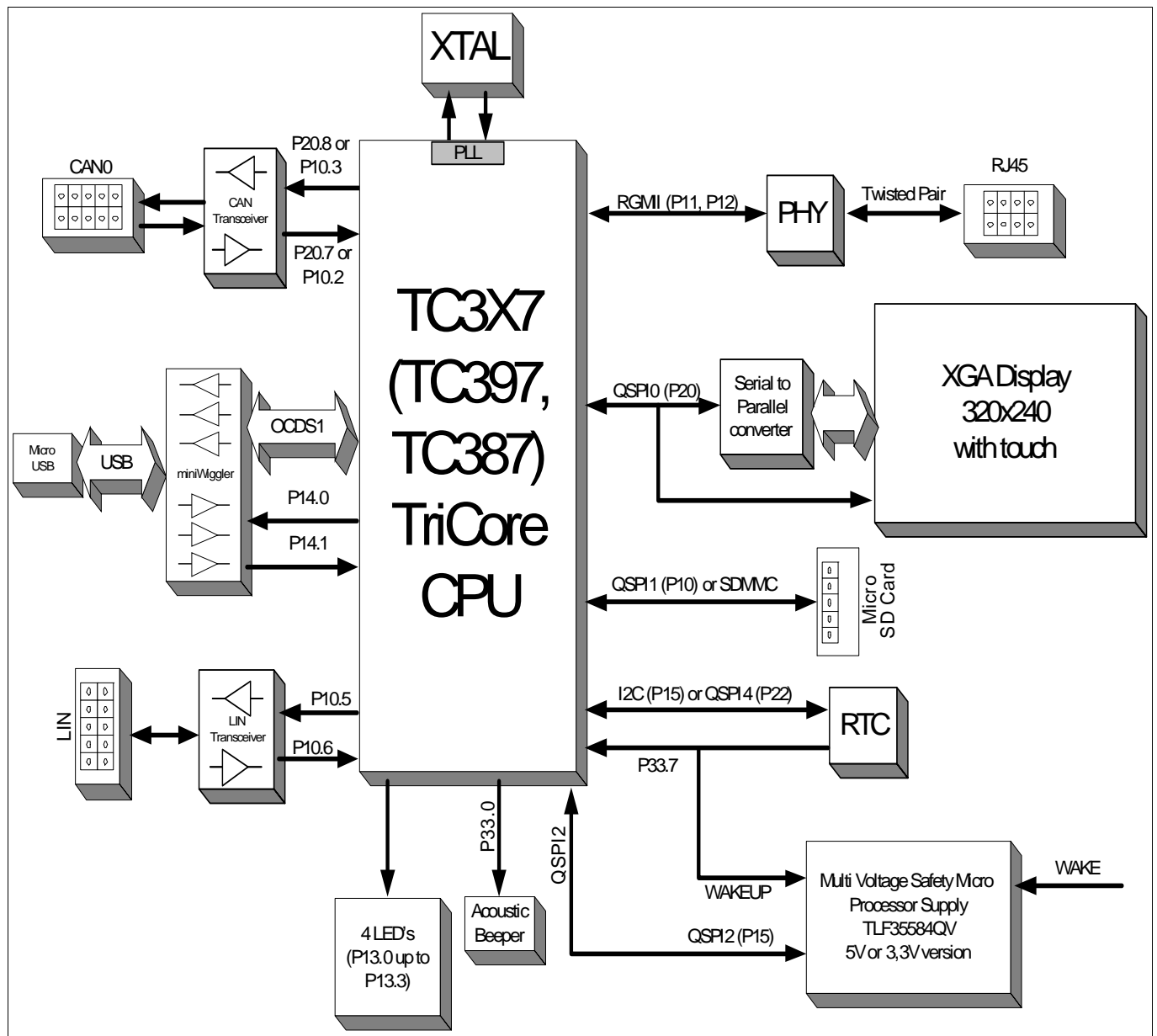

Figure 2-1 Application Kit TC3X7 Block Schematic

Features

2.3 Placement

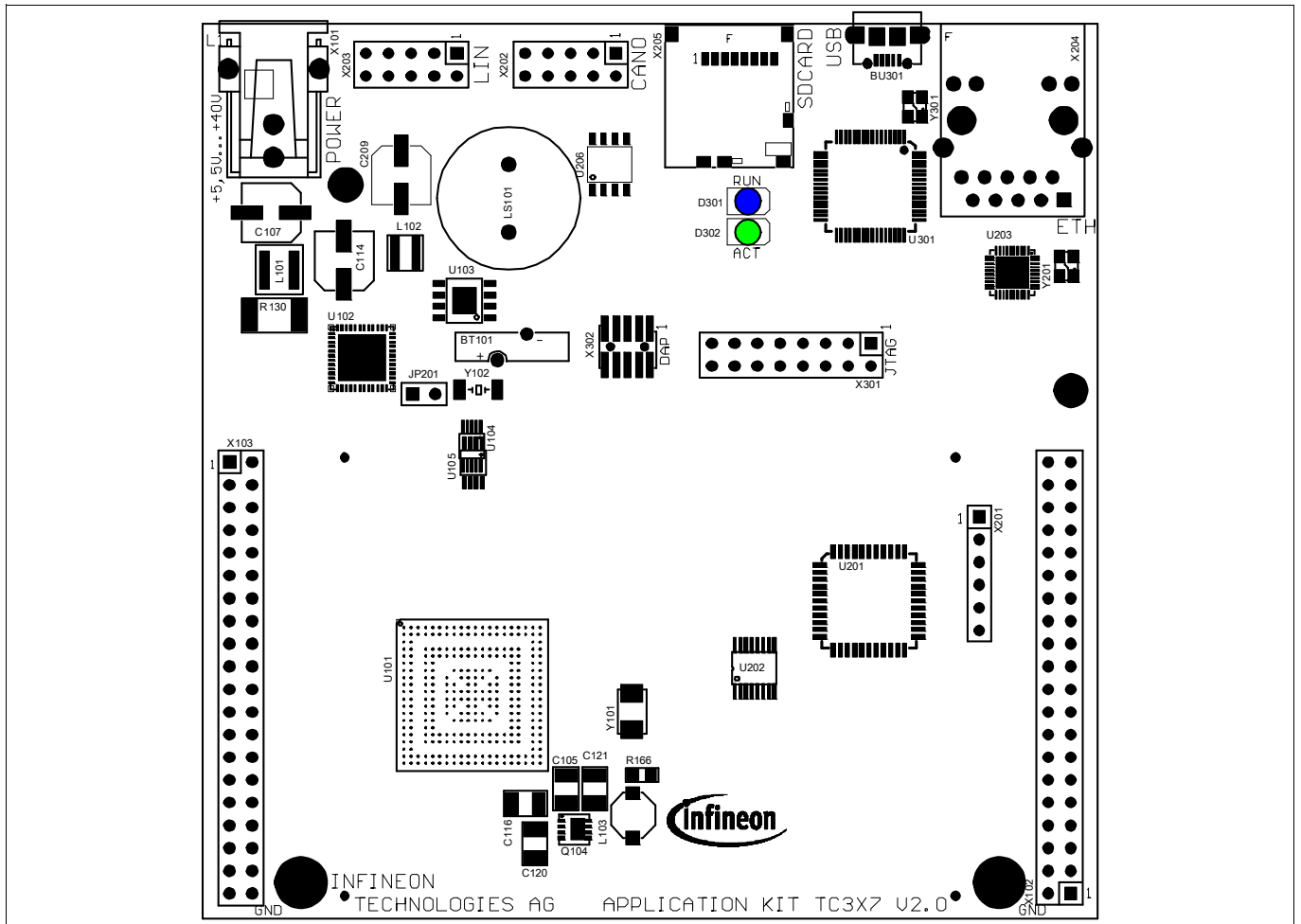

Figure 2-2 Application Kit TC3X7 V2.0 Top Placement

Features

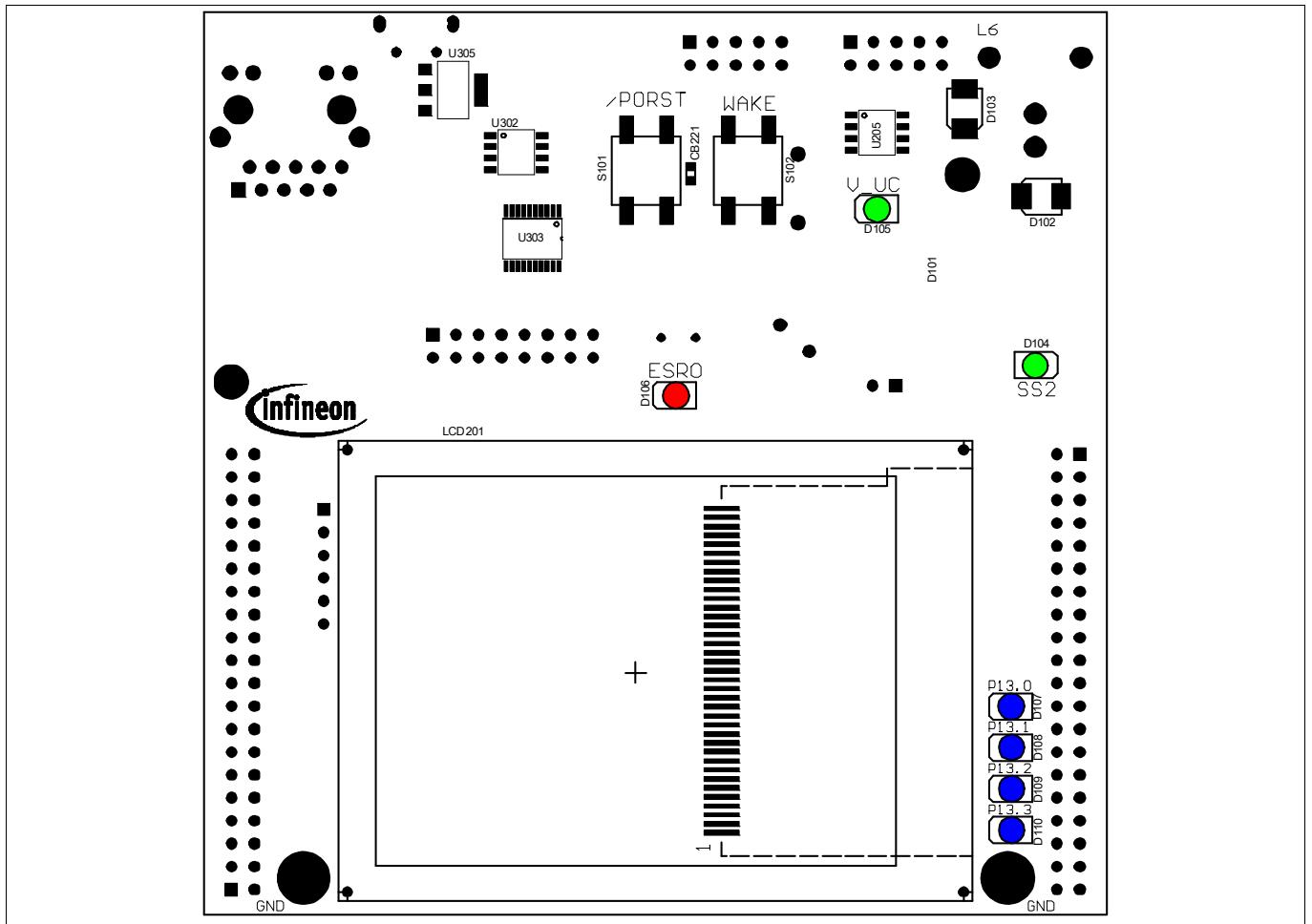

Figure 2-3 Application Kit TC3X7 V2.0 Bottom Placement



## 3 Application Kit Information

### 3.1 Available Boards

The following boards are available:

- Application Kit TC397 V2.0 with VEXT=5V
- Application Kit TC397 V2.0 with VEXT=3,3V
- Application Kit TC387 V2.0 with VEXT=5V
- Application Kit TC387 V2.0 with VEXT=3,3V

If the TLF35584 is stamped with VS1 then the board has VEXT=5V.

If the TLF35584 is stamped with VS2 then the board has VEXT=3,3V.

The used VEXT voltage can also be detected by the supply measurement of the AURIX™ device itself and is measurable on pin 2 of X102 and X103.

*Note: Only on Application Kit TC397 V2.0 with VEXT=3,3V is the SD card connected to the TC397 via SDMMC module and P10.2/3 is used for CAN. All other boards are using QSPI for SD card access and P20.7/8 for CAN.*

### 3.2 Power Supply

All needed voltages are generated via Infineon's Multi Voltage Safety Micro Processor Supply TLF35584QV and via the microcontroller itself (+1,25V).

The supply device is available as two different devices:

TLF35584QVS1 -> +5V standby voltage, +5V TriCore supply (V\_UC)

TLF35584QVS2 -> +3,3V standby voltage, +3,3V TriCore supply (V\_UC)

Dependent of the assembled device the board works with 5V or 3,3V IO.

The TLF35584QV provide the following voltages:

+3,3V or +5V for standby (connected to VEVRSB)

+3,3V or +5V for TriCore (connected to VEXT)

+5V communication supply (used by CAN transceiver and acoustic beeper)

+5V voltage reference (connected to VDDM and VAREF<sub>x</sub>)

+3,3V via LDO directly from pre regulator (connected to VDDP3 and VFLEX and used by Ethernet PHY, display and SD card)

Applying a stable supply voltage causes the power on reset after a short period. The LED (V\_UC) indicate the status of the cpu voltage.

A manual power on reset is executed by pressing the reset button.

The Board has to be connected to a +3,5V to +40V DC power supply.

The board can be powered directly by USB or by the power connector. In case that the voltage on the power connector is higher than the 5V from the USB then the board is powered by power connector.

#### 3.2.1 Power via supply connector (X101)

The Board has to be connected to a +5,5V to +40V DC power supply.

A supply with 6V and 800mA is sufficient. The pinout for the supply connector is shown in [Figure 6-2](#). There can be used any standard power pack with a connector where the positive line is surrounded by the ground line.

## Application Kit Information

### 3.2.2 Power via Micro USB (BU301)

The Board can also be powered by the Micro USB connector. The power consumption of the board is higher than 500mA. Use an USB port which can deliver 900mA (USB 3.0). Most USB hubs are not able to drive more than 100mA and can't be used.

Also it is possible to power the board with a cellular battery charger which has 5V output and use Micro USB for connecting.

The pinout for the USB connector is shown in [Figure 6-3](#).

### 3.2.3 Multi Voltage Safety Micro Processor Supply TLF35584QV

The board has assembled the Safety Micro Processor Supply with the following Features:

- High efficient multi voltage power supply chip
- Serial step up and step down pre regulator for wide input voltage range from 3.0 to 40 V with full performance and low over all power loss
- Low drop post regulator 5.0V/200mA for communication supply (named LDO\_Com)
- Low drop post regulator 3.3 V/600 mA (VS2) or 5.0V/600mA (VS1) for  $\mu$ C supply (named LDO\_ $\mu$ C)
- Provides enable, sync out signal and voltage monitoring (inside device to be added to reset function) for an optional external post regulator for core supply (not used)
- Voltage reference 5.0 V +/- 1% for ADC supply, 150 mA current capability (named Volt\_Ref)
- Two trackers for sensor supply following voltage reference 150 mA current capability each (named Tracker 1 and Tracker 2, not used)
- Standby regulator 3.3 V/10 mA (VS2) or 5.0 V/10 mA (VS1) (named LDO\_Stby)
- Independent voltage monitoring block with reset function
- Configurable functional and window watchdog
- 16-bit SPI
- Safe state control with two safe state signals with programmable delay
- Input voltage monitoring (over voltage switch off)
- Green Product (RoHS compliant)
- ISO26262 compliant
- AEC Qualified

The TLF35584 is connected to the CPU via QSPI2 and use QSPI2\_SLSO1 (P14.2) as chip select. Via this spi connection the power supply will be configured (Watchdog, device states and soon).

For more information see the data sheet of TLF35584.

*Note: The switch to FAILSAFE state is switched off by HW (R127 assembled). If you will use/evaluate all safety features of the TLF35584 make sure that R127 is not assembled and remove R127 if assembled. Make sure that you have a proper initialization of TLF35584 in your software and debugger in this case. If needed you can assemble JP201 (2 pin header). Then you can switch easily with a jumper.*

## 3.3 Real Time Clock

The board is equipped with a RTC MCP79511 (if I2C is not supported by CPU) or MCP79411 (if I2C is supported by CPU) from Microchip. The device is powered from the standby voltage of the TLF35584 and is also powered when the TLF35584 is switched to standby mode. For backup when the TLF35584 is not powered then there is a small battery to hold the value inside the RTC. The MCP79511 is connected to the microcontroller via QSPI4, the MCP79411 is connected to the microcontroller via I2C on P15.4/P15.5. The RTC can trigger an SCU\_REQ4 (P33.7) interrupt (activ low) with the alarms. Also an alarm from the RTC will wake-up (switch on) the board if the board is powered and the supply is switched off.

## Application Kit Information

The MCP79511/MCP79411 contains also an unique ID in the format EUI-48. This id can be used as mac id for ethernet if the assembled CPU support ethernet.

For more information about the RTC please see the datasheet of MCP79511/MCP79411.

### 3.4 XGA Display

The board has an XGA Display with a resolution of 320x240. The display has an ILI9341 display controller. Please see the datasheet of the display controller for the register of the controller. The display is connected to the the microcontroller via an SPI to Parallel converter (U201).

The SPI to Parallel converter is based on a statemachine. This state machine is clocked with the clock of SPI, here SCLK0 (P20.13). Each rising edge of P20.13 will change the state of statemachine. When SLSO08 (P20.6) is not low then the state machine will go always in the idle state with a valid clock edge.

The background light is switched on via port 15 pin 0. An high level on this port pin enable the background light.

#### 3.4.1 Write a display register

A single write to any register can be done by a 32 bit transfer of SPI. Make sure that the SLSO08 is low during this 32 bit. Bit 31 must be transfered first.

Bit 31 must be 0, this will be indicate a write access.

Bit 30 must be 0, this will be indicate a single access.

Bit 29...Bit 22 is the 8 bit register number which will be written

Bit 21...Bit 6 is the 16bit value which will be written

Bit 5...Bit 0 are dummy bits which are used to execute the write.

To speedup the writing (e.g. write to ram of display controller) it is possible to make a endless transfer. This is done by this:

first 10 bit transfer

Bit 9 must be 0, this will be indicate a write access.

Bit 8 must be 1, this will be indicate an endless transfer.

Bit 7...Bit 0 is the 8 bit register number which will be written

Now you need to transfer only 16bit values for the registers. With the first 16 bit value there is no action on the display. With the second value transfer is a write to the register started. This means after the last value you must make a dummy transfer to write the last value.

The endless mode can only be leave by a rising edge of SCLK0 with SLSO08 set to high. This can be done by a dummy transfer to any other chip select or by a transfer from the touch controller.

#### 3.4.2 Read a display register

A single read from any register can be done by a 32 bit transfer of SPI. Make sure that the SLSO08 is low during the complete transfer.

first transfer has 16 bit:

Bit 15 must be 1, this will be indicate a read access.

Bit 14 must be 0, this will be indicate a single access.

Bit 13...Bit 7 is the 8 bit register number which will be read

Bit 5...Bit 0 are dummy bits to setup the register number.

second transfer must have 26 bits:

Bit 25...Bit 16 are dummy bits which are needed to readout the register value

## Application Kit Information

Bit 15...Bit 0 are dummy bits to transfer the readed value.

To speedup the reading (e.g. reading from ram of display controller) it is possible to make a endless transfer. This is done by this:

first 16 bit transfer:

first transfer has 16 bit:

Bit 15 must be 1, this will be indicate a read access.

Bit 14 must be 1, this will be indicate an endless access.

Bit 13...Bit 7 is the 8 bit register number which will be read

Bit 5...Bit 0 are dummy bits to setup the register number.

second 10 bit transfer:

Bit 9...Bit 0 are dummy bits which are needed to readout the register value

Now you need to transfer only 16bit values for the registers. With the each 16 bit transfer you get a value. With the last transfer you have dummy read which you don't get the result.

The endless mode can only be leave by a rising edge of SCLK0 with SLSO08 set to high. This can be done by a dummy transfer to any other chip select or by a transfer from the touch controller.

### 3.4.3 Touch controller

The touch of display is connected to an Touch controller ADS7843. This controller is connected via the QSPI0 and SLSO9 (P20.3) to the microcontroller. For more information about the delivered values from the touch controller please see the datasheet of ADS7348.

### 3.5 Micro SD card

The board has a slot to use the board with an micro SD card. If the board is assembled with TC397 and a TLF35584QVVS2 (3,3V version) then the SDMMC module is connected directly to the SD card. In this case R251 up to R256 are assembled instead of R261 up to R268.

In all other cases the card can be used in SPI mode only. In this case the SD card is connected to QSPI1 with chip select 9 (P10.5) of QSPI1.

Please see additional literature how to use a SD card in SPI mode.

### 3.6 LEDs

There are 8 LEDs on board:

- D107 up to D110 (blue) -> toogle LEDs connected to P13.0 ... P13.3
- D106 ESR0 (red) -> RESET LED indicate the reset state of the board
- D105 V\_UC (green) -> V\_UC power supply indication
- D104 SS2 (green) -> safe state signal 2 of TLF35584
- D302 ACT (green) -> on board miniWiggler JDS is ACTIV
- D301 RUN (blue) -> Debug RUN mode (switched by DAS Server)

### 3.7 Clock

On the board is a fixed crystal with 20MHz assembled. You can change this by replacing Y101 (soldered).

### 3.8 USB Connector

The USB connector is used for connection to a PC. Via the USB it is possible to power the board, using the ASCLIN0 as serial connection via USB and Debugging via DAS. For the pinout of USB socket see [Figure 6-3](#).

## Application Kit Information

NOTE: Before connecting the board to the PC, make sure that the actual DAS software is installed on the PC. For actual DAS software please contact your local FAE.

The software can also be found on:

[DAS website](#)

### 3.8.1 Serial Connection to PC

After the first connection of USB to a PC the needed driver will be installed automatically. During this there will be created a new COM port on PC. This COM port can be used to communicate with the board via ASCLIN0 of the device. Per default the ASCLIN0 is used on P14.0 and P14.1 (e.g. Generic Bootstrap Loader).

### 3.8.2 miniWiggler JDS

The miniWiggler JDS is a low cost debug tool which allows you access to the JTAG of the device. Make sure that you have the latest DAS release. Debugging is possible via the DAS Server 'UDAS'. Please contact your preferred debug vendor for support of DAS.

If you have connected the board to the PC and there runs the DAS server, then a working connection is visible via the green ACTIV LED.

The status RUN LED is switched on/off through the DAS Server, depending on the used debugger (client).

**IMPORTANT: Make sure that there is no or a tristated connection on X301 (OCDS1) and X302 (DAP) if the ACTIV LED is on.**

### 3.9 Beeper

The board has an electro-acoustic transducer which can be used for an acoustic output. The transducer is connected to pin P33.0 and needs a 2048Hz frequency.

### 3.10 MultiCAN

On the board is one CAN transceiver (CAN FD capable) connected to the CAN module 0 node 0 (P20.7 and P20.8) on TC3X7. Optional the CAN transceiver can be connected to CAN module 0 node 2 (P10.2 and P10.3). To do this remove resistor R269, R270 and assemble R257, R258 with 0R Resistor. For location of this resistors please see the Top Layer assembling [Figure 7-5](#).

*Note: If the board is assembled with TC397 and TLF35584QVVS2 (3,3V version) then the SDMMC module is connected directly to the SD card. In this case P20.7 and P20.8 are used by the SDMMC and the transceiver is connected to P10.2 and P10.3.*

The transceiver is connected to an IDC10 plug. For the pinout of IDC10 plug see [Figure 6-4](#). You can use a IDC female connector with crimpconnector, flat cable and SUB-D 9 plug with crimpconnector to have a 1:1 adapter to SUB-D 9.

### 3.11 LIN

On the board is one LIN transceiver connected to the ASCLIN2 (P10.5 and P10.6) on TC3X7. The transceiver are connected to one IDC10 plug. For the pinout of IDC10 plug see [Figure 6-5](#). You can use a IDC female connector with crimpconnector, flat cable and SUB-D 9 plug with crimpconnector to have a 1:1 adapter to SUB-D 9.

### 3.12 Ethernet

The Application Kit provide a RJ45 connector (X204) for twisted pair ethernet connections. The board use a Realtek Integrated 10/100/1000M Ethernet Precision Transceiver RTL8211FI-CG as physical interface device. For

## Application Kit Information

more information about the ethernet modul see TC3X7 User's Manual, about the PHY see the RTL8211F datasheet. For the pinout of RJ45 see [Figure 6-6](#).

For the connection between TriCore and PHY is used the RGMII.

### 3.13 Core current measurement

It is possible to measure the core (+1,25V) current with two ADC pins of the CPU. This can be done by synchronous measurement of AN36 and AN44. The pins are connected together by an 50mOhm resistor. The current can be calculated by the following formula:

$I_{core} = (VAN44 - VAN36) / 0,05$ . To get an valid result the measurement must be done synchronous.

### 3.14 Other peripherals

For all other peripherals there are no special plugs on the board. Many of the peripheral signals are available on the two standard connectors X102 and X103, see ["Connector Pin Assignment" on Page 6-1](#).

### 3.15 Toggle LED's

The status LED's are low active and can be controlled by Software.

Port 13 pin 0 up to pin 3 are connected to single LED's (D107... D110) and powered by the normal microcontroller voltage.

### 3.16 Buttons

On the board are two buttons.

The reset button (S101) will apply a warm power on reset to the device.

The WAKE button (S102) will be used to enable/wakeup the TLF35584.

### 3.17 Debug System

#### 3.17.1 OCDS1

The OCDS1 signals are connected to the IDC16 plug (X401). They work with the port supply of Microcontroller (+5V default or +3,3V). For pinout of the connector see [Figure 6-7](#). You can connect any debugger to this connector.

The signals /BRKIN and /BRKOUT are not connected.

If you connect a debug hardware make sure that the miniWiggler JDS (see ["miniWiggler JDS" on Page 3-5](#)) is not activ (ACTIV LED is off) and on the DAP connector (X302) is no hardware connected or the hardware is tristated.

If the ACTIV LED is on, then stop the active DAS Server 'UDAS' and/or remove the USB connection to the PC.

#### 3.17.2 DAP

The board comes with a DAP connector (X302). For pinout of this connector see [Figure 6-8](#). You can connect a DAP hardware here. If you use this connector make sure that the miniWiggler JDS is not activ (ACTIV LED is off) and a connected OCDS1 hardware is disconnected or tristated.

## 4 Application Kit Configuration

The Application Kit has a fixed configuration which can be slightly changed. For locating components see [Figure 7-5](#) and [Figure 7-6](#).

### 4.1 Default Pad State

The default pad state is that the internal pull-up devices on the I/O pins are enabled. This can be changed by assembling resistor R143 with 2K2 (drive P14.4 / HWCFG6 low). If the resistor R143 is assembled then all I/O pins are in tristate. Additionally you must make sure that R134 is also assembled with 10K that the EVRC is enabled properly in this case.

### 4.2 Bootmode

The bootmode is fixed set to Start-up mode is selected by Boot Mode Index. This can be changed to boot from pins and Internal Start from Flash by removing resistor R133 (drive P14.3 / HWCFG3 high) and assembling resistor R142 with 2K2 (drive P14.3 / HWCFG3 low). If the I/O pins are set to tristate per default (R143 assembled) then you must assemble also resistor R134 and resistor R272 with 10K to set the HWCFG pins to proper values.



Signal (on board used) Description

## 5 Signal (on board used) Description

For more information about the signals please see the user manual/datasheet for TC3X7 and/or the schematics of the board.

All not mentioned signals are not used on the board and can be used outside if they are connected to the IO Connectors see [Figure 6-1](#). Optional marked signals are used only if they are connected (default is that they are not used on the board).

### 5.1 Power Signals

Table 5-1 Power Signals

Short name	Description
VCC_IN	Supply Input (3,5V...40V)
VIN	Input Voltage of Power Supply Device
GND	Ground
V_PREPEEG	Pre Regulator Voltage (~5,8V)
+3V3	Supply Voltage (3,3V)
+5V	Supply Voltage (5V)
V_UC	Microcontroller Supply Voltage (5V or 3,3V depends on assembled TLF35584)
VREF_5V	Reference Supply Voltage (5V)
QST	Standby Supply Voltage (5V or 3,3V depends on assembled TLF35584)
VDD	Core Supply Voltage (1,25V)
VDDM	ADC Analog Part Supply Voltage (5V or 3,3V selectable via 1R resistors)
VAREF1	ADC Reference Voltage 1 (5V or 3,3V selectable via 4R7 resistors)
VAREF2	ADC Reference Voltage 2 (5V or 3,3V selectable via 4R7 resistors)
VDD_USB	Supply Voltage from USB (5V)
VDD_FT	Supply Voltage FT2232HL device (3,3V)

### 5.2 Reset Signals

Table 5-2 Reset Signals

Short name	Description
/PORST	Power On Reset
/ESR0	External Service Request 0 (Hardware Reset)
/ESR1	External Service Request 1 (Non Maskable Interrupt)

### 5.3 Config Signals

Table 5-3 Config Signals

Short name	Description
P14.5	HWCFG1 (EVR33OFF)
P14.2	HWCFG2 (EVRCON)
P14.4	HWCFG6 (Pins in tristate / Pins with pull-up)



Signal (on board used) Description

**Table 5-3 Config Signals** (continued)

Short name	Description
P14.3	HWCFG3 (Boot from pins / Boot from Flash BMI)
P10.5	HWCFG4 (Boot from internal flash)
P10.6	HWCFG5 (Boot from internal flash )

## 5.4 Clock Signals

**Table 5-4 Clock Signals**

Short name	Description
XTAL1	Crystal Oscillator Input
XTAL2	Crystal Oscillator Output

## 5.5 Debug Signals

**Table 5-5 Debug Signals**

Short name	Description
/TRST	Test Reset
DAP0	Device Access Port Line 0 / Test Data Clock (TCK)
DAP1	Device Access Port Line 1 / Test Data Select (TMS)
P21.6	Test Data Input (TDI)
P21.7	DAP2 / TDO from debug connectors

## 5.6 Peripheral Signals

**Table 5-6 Peripheral Signals**

Short name	Description
P14.1	ASCLIN0 Receive Input A
P14.0	ASCLIN0 Transmit Output
P10.6	ASCLIN2 Receive Input D
P10.5	ASCLIN2 Transmit Output
P15.4	I2C0 Serial Clock
P15.5	I2C0 Serial Data Input C und Output
P33.7	RTC Alarm Interrupt Input
P20.7	CAN00 Receive Input B
P20.8	CAN00 Transmit Output
P10.2	CAN02 Receive Input E (optional)
P10.3	CAN02 Transmit Output (optional)
P11.0	Ethernet TXD3 Output
P11.1	Ethernet TXD2 Output
P11.2	Ethernet TXD1 Output

Signal (on board used) Description

Table 5-6 Peripheral Signals (continued)

Short name	Description
P11.3	Ethernet TXD0 Output
P11.4	Ethernet TXCLK Output
P11.5	Ethernet GREFCLK Input
P11.6	Ethernet TCTL Output
P11.7	Ethernet RXD3 Input A
P11.8	Ethernet RXD2 Input A
P11.9	Ethernet RXD1 Input A
P11.10	Ethernet RXD0 Input A
P11.11	Ethernet RCTL Input A
P11.12	Ethernet RXCLK Input A
P12.0	Ethernet Management Data Clock Output (MDC)
P12.1	Ethernet Management Data Input/Output (MDIO)
P10.8	Ethernet MD Interrupt Input
P02.1	Ethernet MD Interrupt Input (optional)
P14.2	QSPI2 Slave Select Output 1 for /SCS of TLF35584
P15.3	QSPI2 Master Clock Output for SCL of TLF35584
P15.6	QSPI2 Master Transmit Output for SDI of TLF35584
P15.7	QSPI2 Master Receive Input B for SDO from TLF35584
P14.3	Output for Watchdog Input of TLF35584
P33.8	SMU_FSP0 Output for Error Signal Input of TLF35584
P33.9	Input for Safe State Signal 1 from TLF35584
P20.6	QSPI0 Slave Select Output 8 for /CS of Display
P20.3	QSPI0 Slave Select Output 9 for /CS of Touch
P20.13	QSPI0 Master Clock Output for SCLK of Display and Touch
P20.14	QSPI0 Master Transmit Output for SDI of Display and Touch
P20.12	QSPI0 Master Receive Input A for SDO from Display and Touch
P20.9	Interrupt Input from Touch /PENIRQ
P15.0	PWM or static Output for Display Backlights
P10.5	QSPI1 Slave Select Output 9 for /CS of SD card
P10.2	QSPI1 Master Clock Output for SCLK of SD card
P10.3	QSPI1 Master Transmit Output for SDI of SD card
P10.1	QSPI1 Master Receive Input A for SDO from SD card
P10.7	Interrupt Input from Card Detect Signal
P02.0	Interrupt Input from Card Detect Signal (optional)
P13[0...3]	On board LED's
P33.0	PWM Signal for Acoustic beeper
P23.1	QSPI4 Slave Select Output 6 for CS of MPC79511 (optional)
P22.3	QSPI4 Master Clock Output for SCK of MPC79511 (optional)

Signal (on board used) Description

Table 5-6 Peripheral Signals (continued)

Short name	Description
P22.0	QSPI4 Master Transmit Output for SI of MPC79511 (optional)
P22.1	QSPI4 Master Receive Input B for SO from MPC79511 (optional)
P15.1	SDMMC0 Clock Output for SD card (optional)
P15.3	SDMMC0 Command Output for SD card (optional)
P20.7	SDMMC0 Data 0 Input/Output for SD card (optional)
P20.8	SDMMC0 Data 1 Input/Output for SD card (optional)
P20.10	SDMMC0 Data 2 Input/Output for SD card (optional)
P20.11	SDMMC0 Data 3 Input/Output for SD card (optional)

Connector Pin Assignment

## 6 Connector Pin Assignment

The Application Kit will be shipped with two 40 pin male (plug) connectors on top layer with a standard grid of 2,54mm.

### 6.1 I/O connectors TC387 and TC397

X103			X102		
(VCC_IN)	1 2	V_UC	P14.5	40 39	P14.4
GND	3 4	GND	P33.10	38 37	P33.9
P21.2	5 6	P21.3	P15.7	36 35	P15.6
P14.8	7 8	P14.7	P15.5	34 33	P15.4
P14.6	9 10	P20.0	P15.8	32 31	P15.2
P21.4	11 12	P21.5	P22.3	30 29	P22.2
P02.0	13 14	P02.1	P22.1	28 27	P22.0
P02.2	15 16	P02.3	P33.11	26 25	P23.4
P02.4	17 18	P02.5	P23.3	24 23	P23.2
P02.6	19 20	P02.7	P23.1	22 21	P23.0
P02.8	21 22	P00.0	P33.6	20 19	P33.8
P00.1	23 24	P00.2	P33.12	18 17	P33.1
P00.3	25 26	P00.4	P33.2	16 15	P33.3
P00.5	27 28	P00.6	P33.4	14 13	P33.5
P00.7	29 30	P00.8	AN0	12 11	AN8
P00.9	31 32	P00.10	AN2	10 9	AN3
P00.11	33 34	P00.12	AN11	8 7	AN13
AN19	35 36	AN18	AN20	6 5	AN21
AN17	37 38	AN16	GND	4 3	GND
AN25	39 40	AN24	V_UC	2 1	(VCC_IN)

Figure 6-1 IO connectors for TC387 and TC397 - Pinout

Note: VCC\_IN is connected to X102 and X103 with a 0R resistor which is not assembled by default to avoid shortcut to VEXT in case of measurement on the connector. If VCC\_IN needed on X102 and X103 then assemble R113 with a resistor 0R size 0805. Pin 1 of X102 and X103 are always connected together.

### 6.2 Power connector pinout

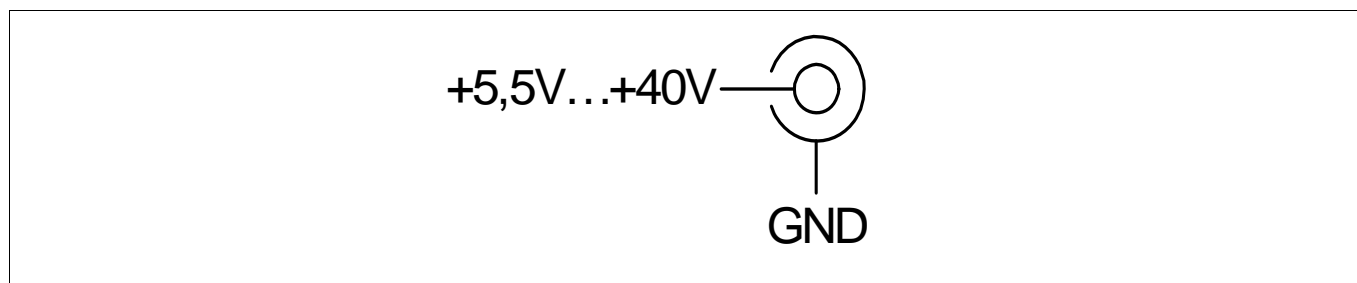

Figure 6-2 Power connector pinout (Roka 520 2550)

Connector Pin Assignment

### 6.3 USB connector pinout

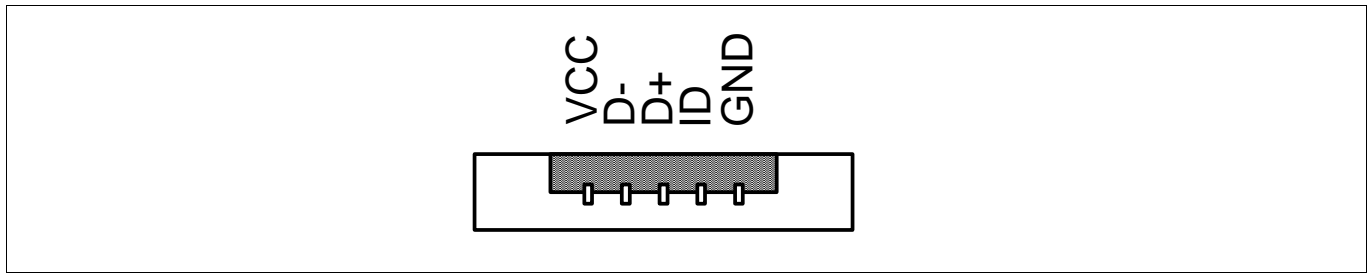

Figure 6-3 USB connector pinout (Micro USB B-type)

### 6.4 CAN connector pinout

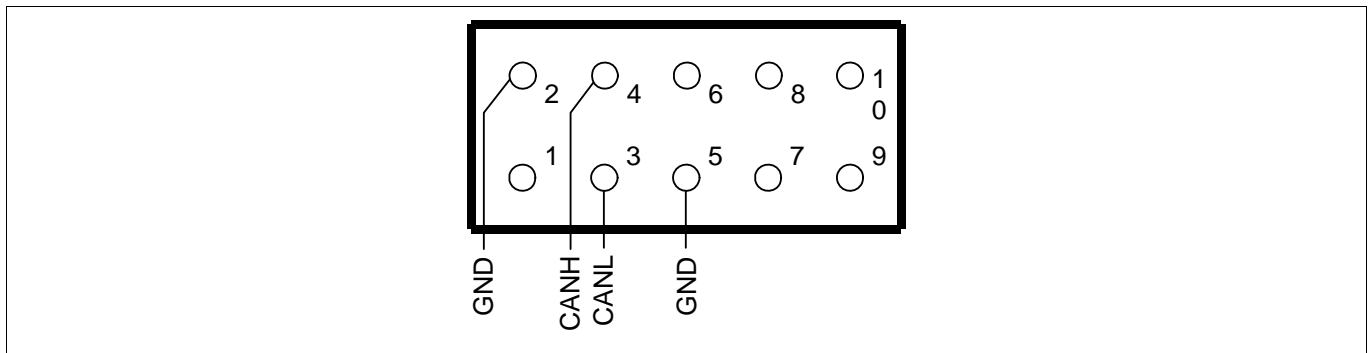

Figure 6-4 CAN connector pinout (IDC10)

### 6.5 LIN connector pinout

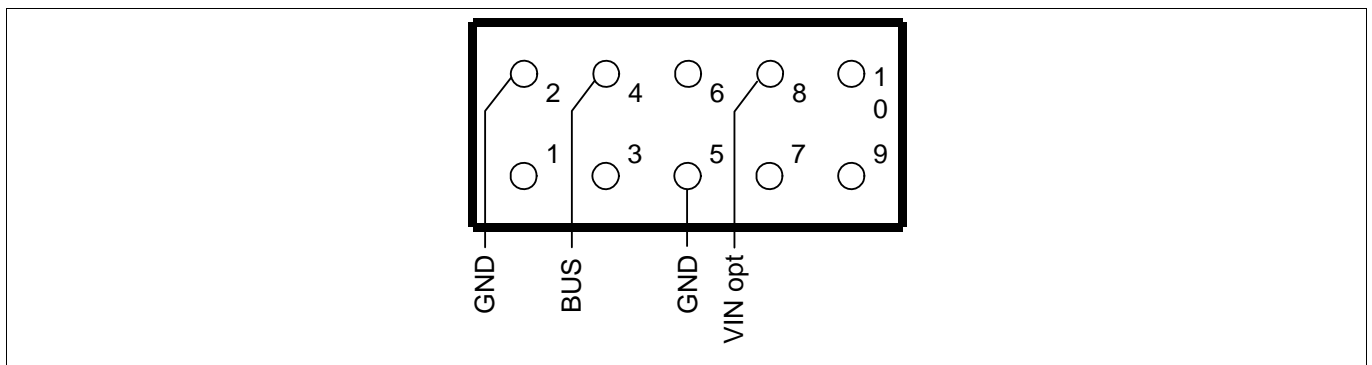

Figure 6-5 LIN connector pinout (IDC10)

Connector Pin Assignment

### 6.6 Ethernet connector pinout

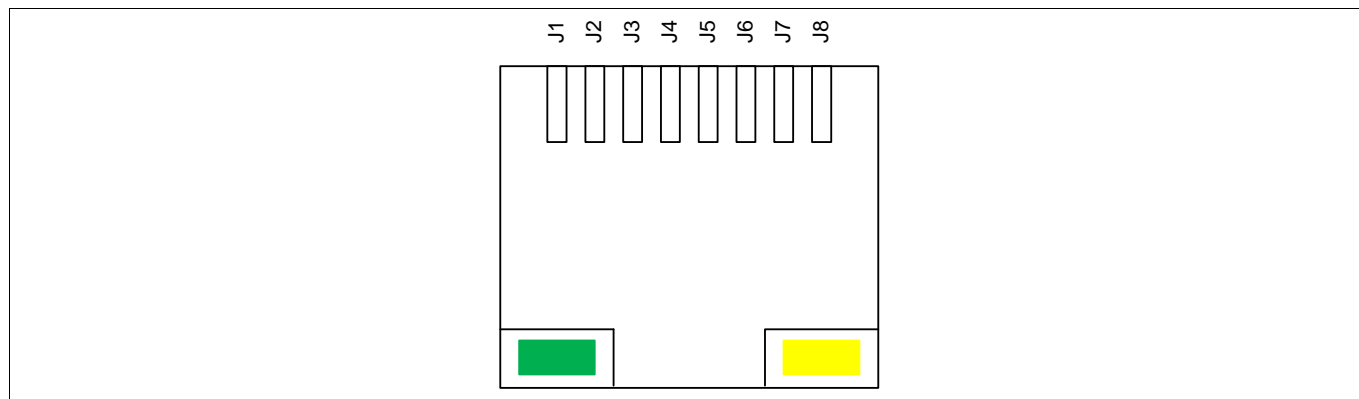

Figure 6-6 Ethernet connector pinout (RJ45)

### 6.7 OCDS1 connector pinout

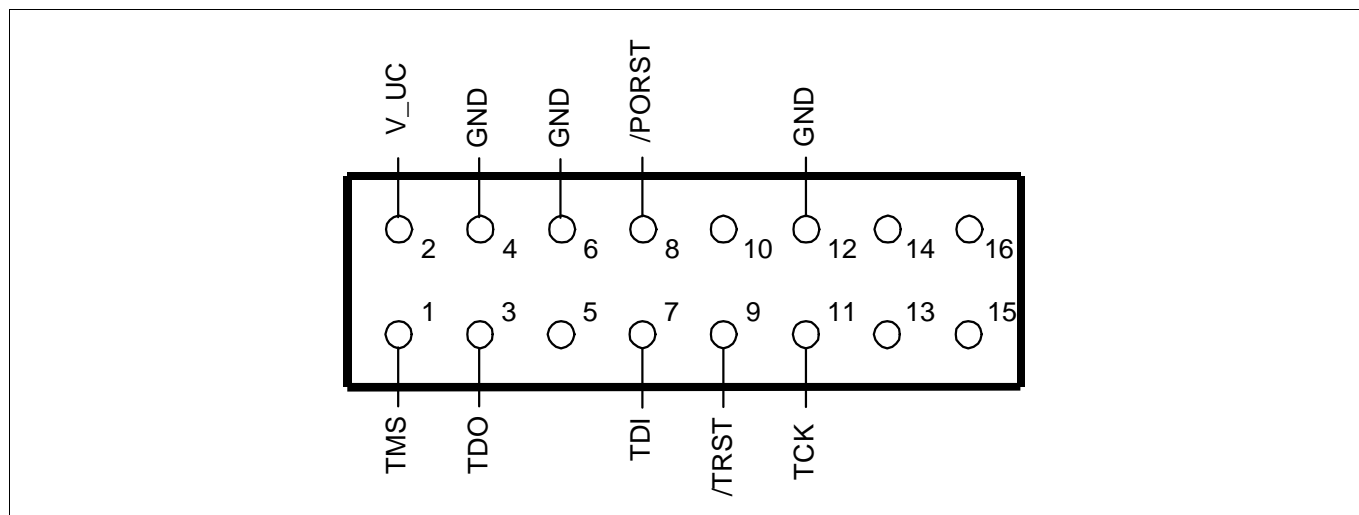

Figure 6-7 OCDS1 connector pinout (IDC16)

### 6.8 DAP connector pinout

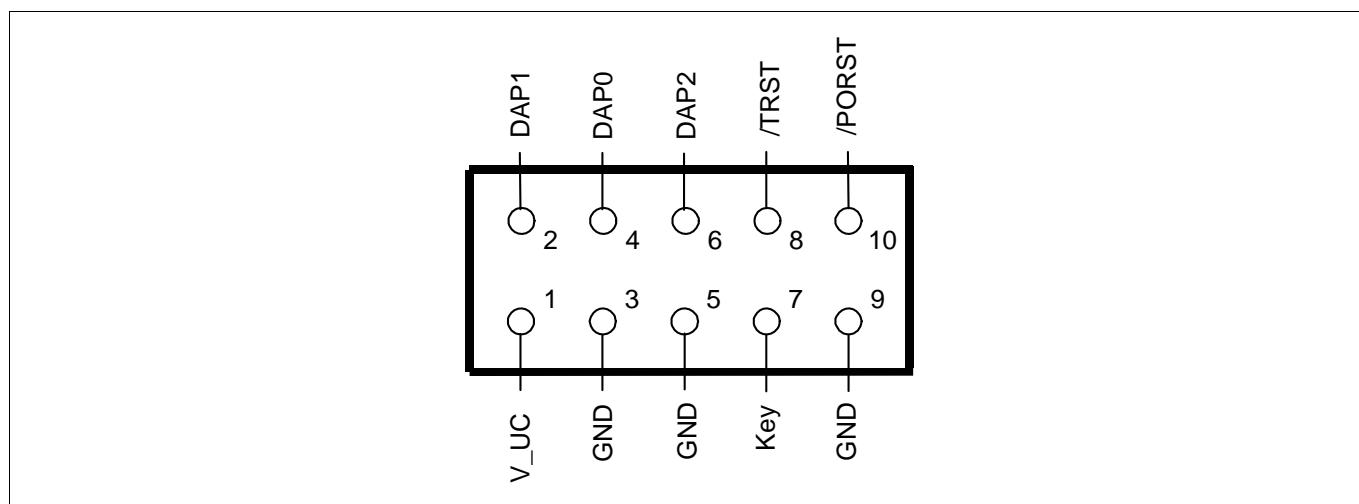

Figure 6-8 DAP connector pinout (Samtec FTSH10)

## Schematic and Layout

# 7 Schematic and Layout

## 7.1 Known problems

No problems known.

## 7.2 Schematic

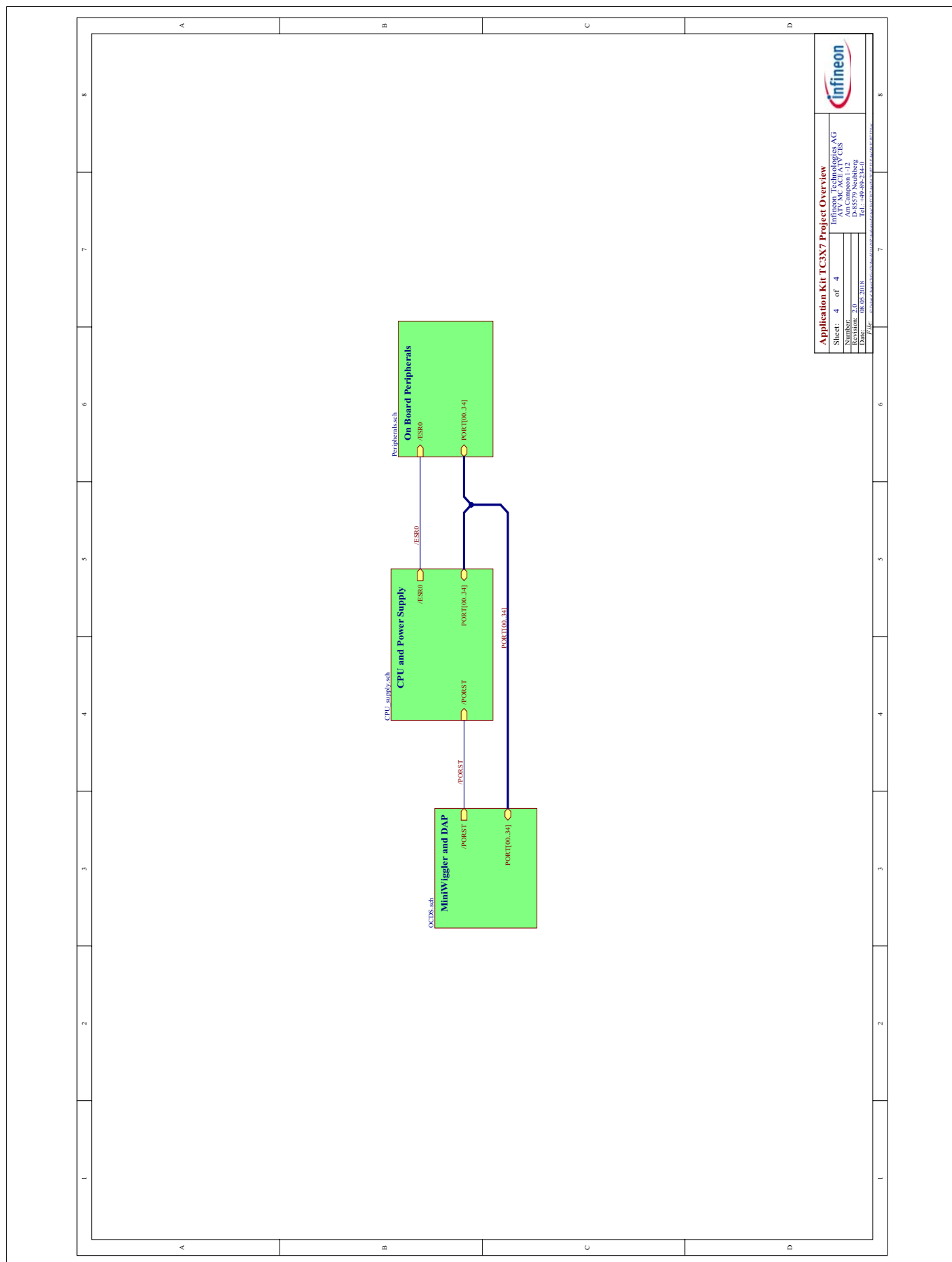

Figure 7-1 Schematic - Project Overview





Schematic and Layout

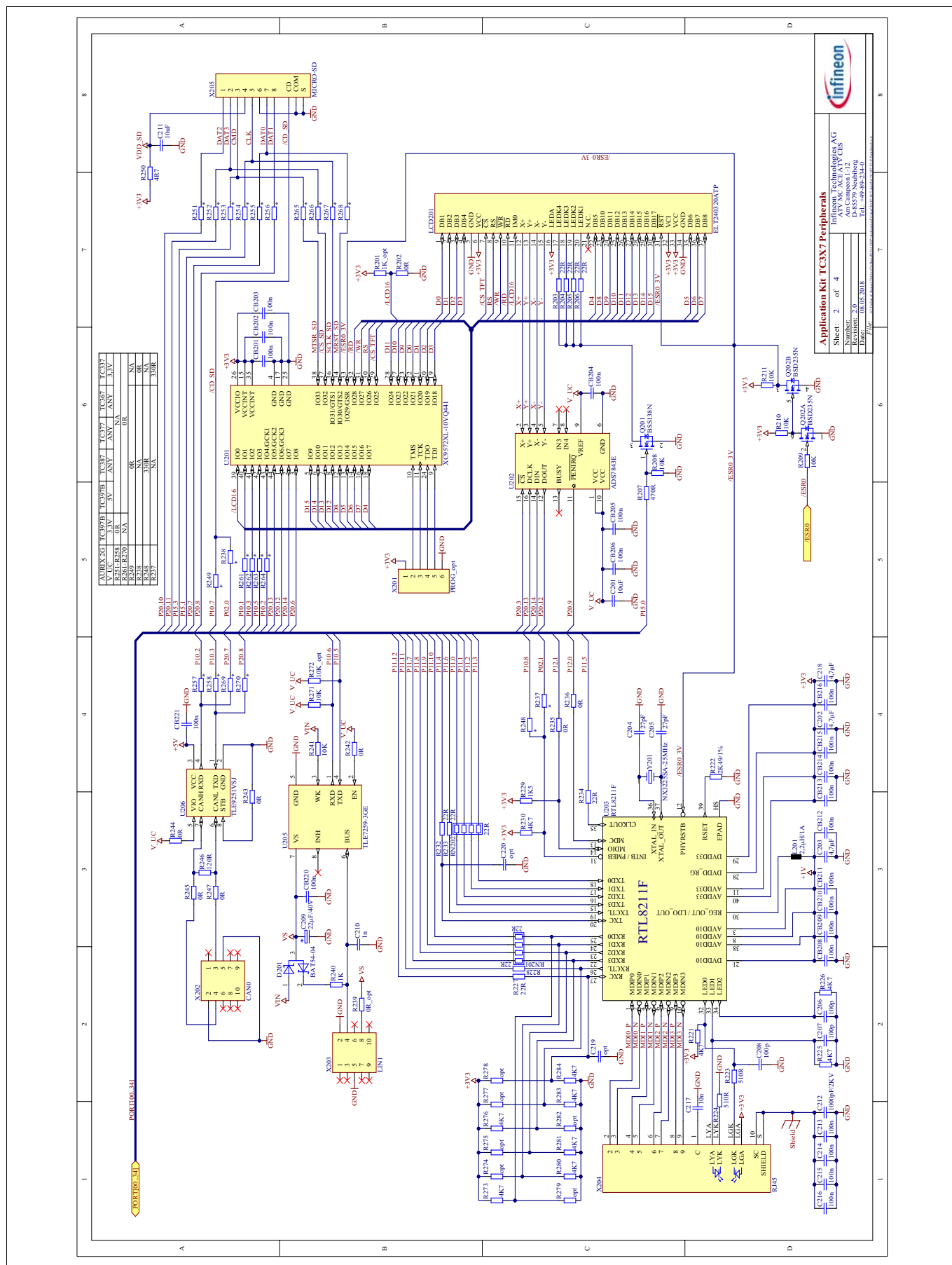
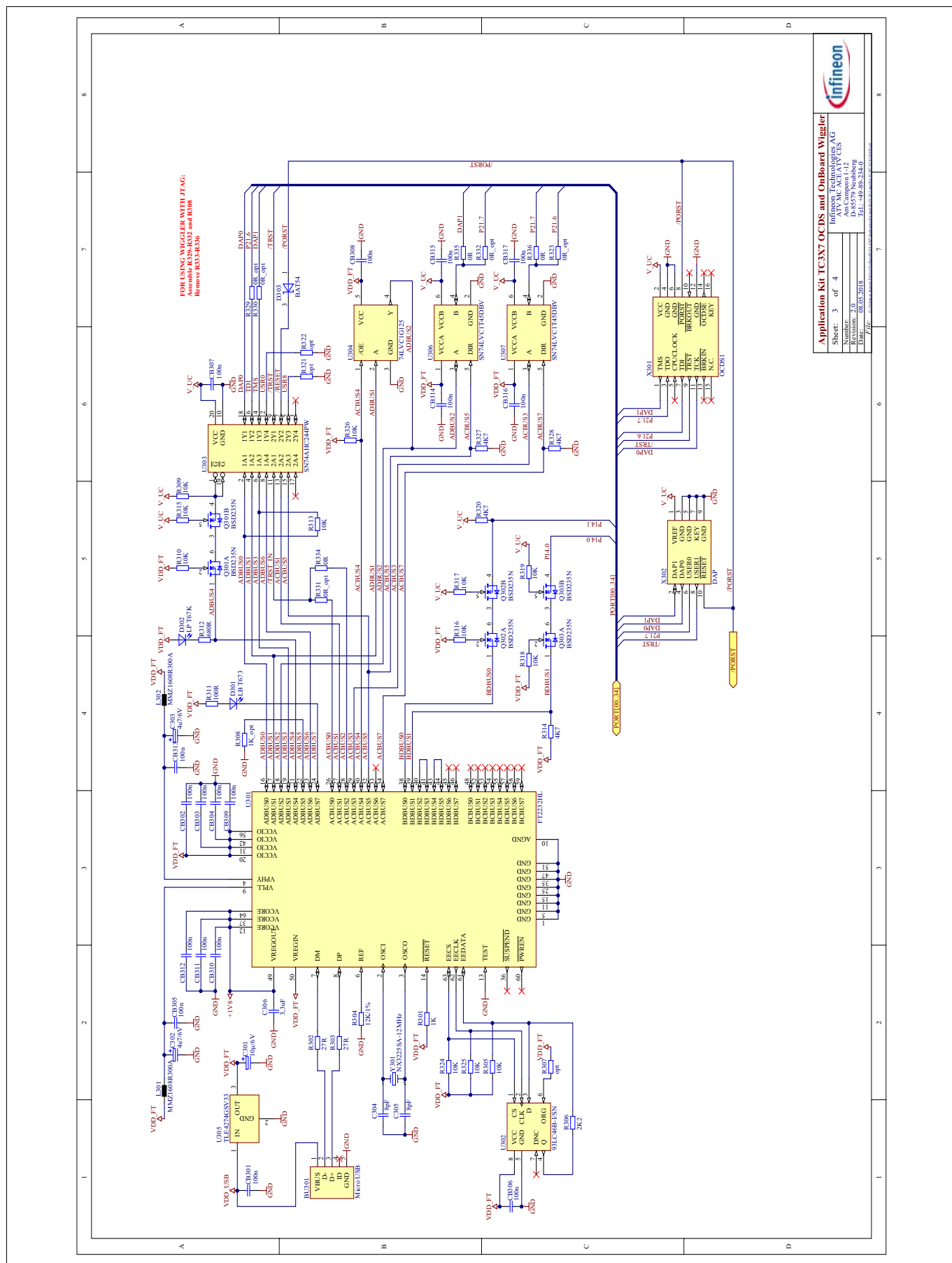

Figure 7-3 Schematic - On Board Peripherals

### Schematic and Layout



**Application Kit TC3X7 OCDS and OnBoard Wiggler**

Infineon Technologies AG  
 Application Kit TC3X7 V2.0  
 Am-Compass 1.12  
 D-85579 Neubiberg  
 TEL: +49-89-2342-40

Sheet: 3 of 4  
 Number: 6502018  
 Revision: 2.0  
 Date: 08/05/2018

Figure 7-4 Schematic - miniWiggler JDS and Debug connectors

### 7.3 Layout

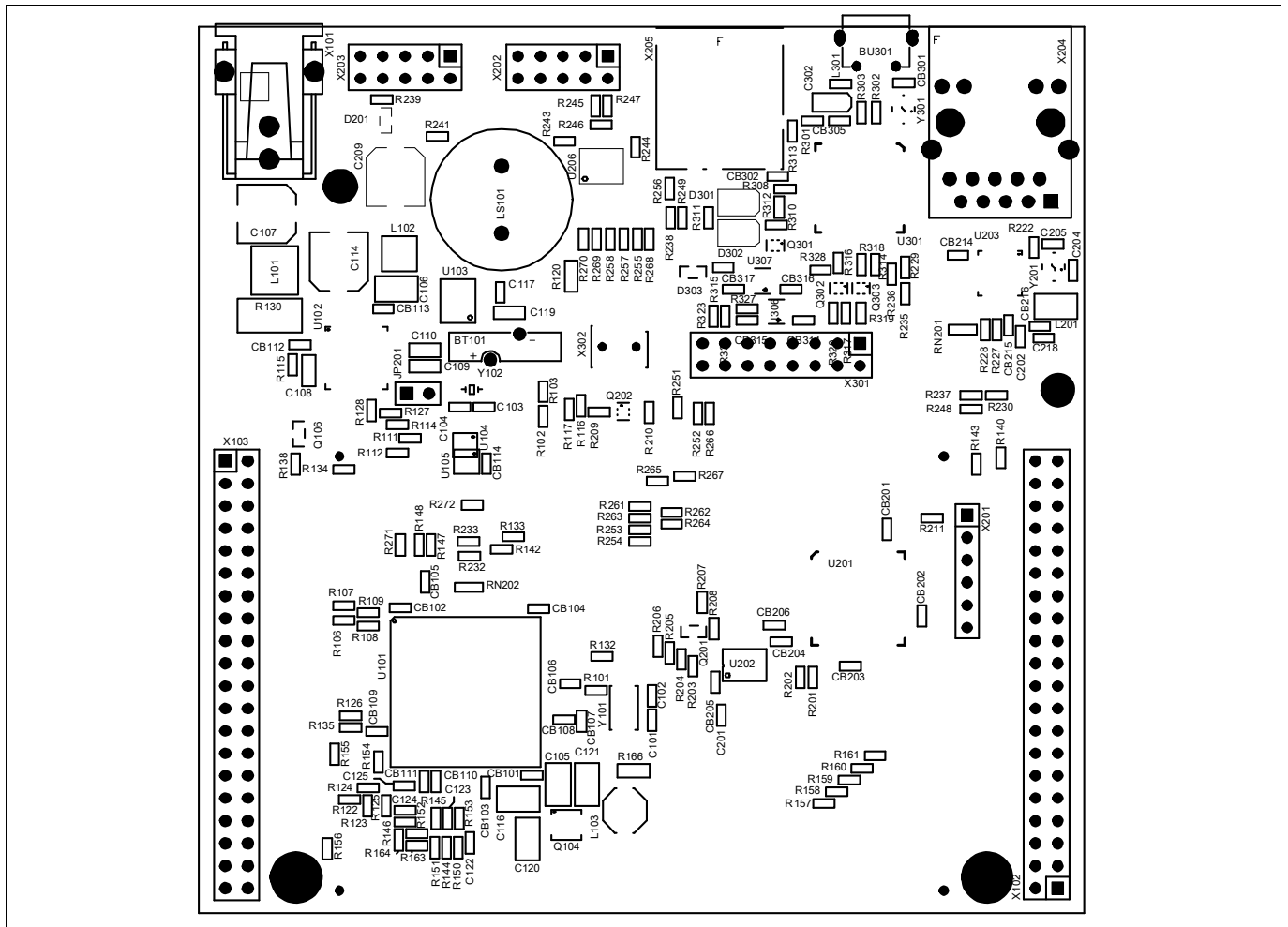

Figure 7-5 Component Plot Top Layer

Schematic and Layout

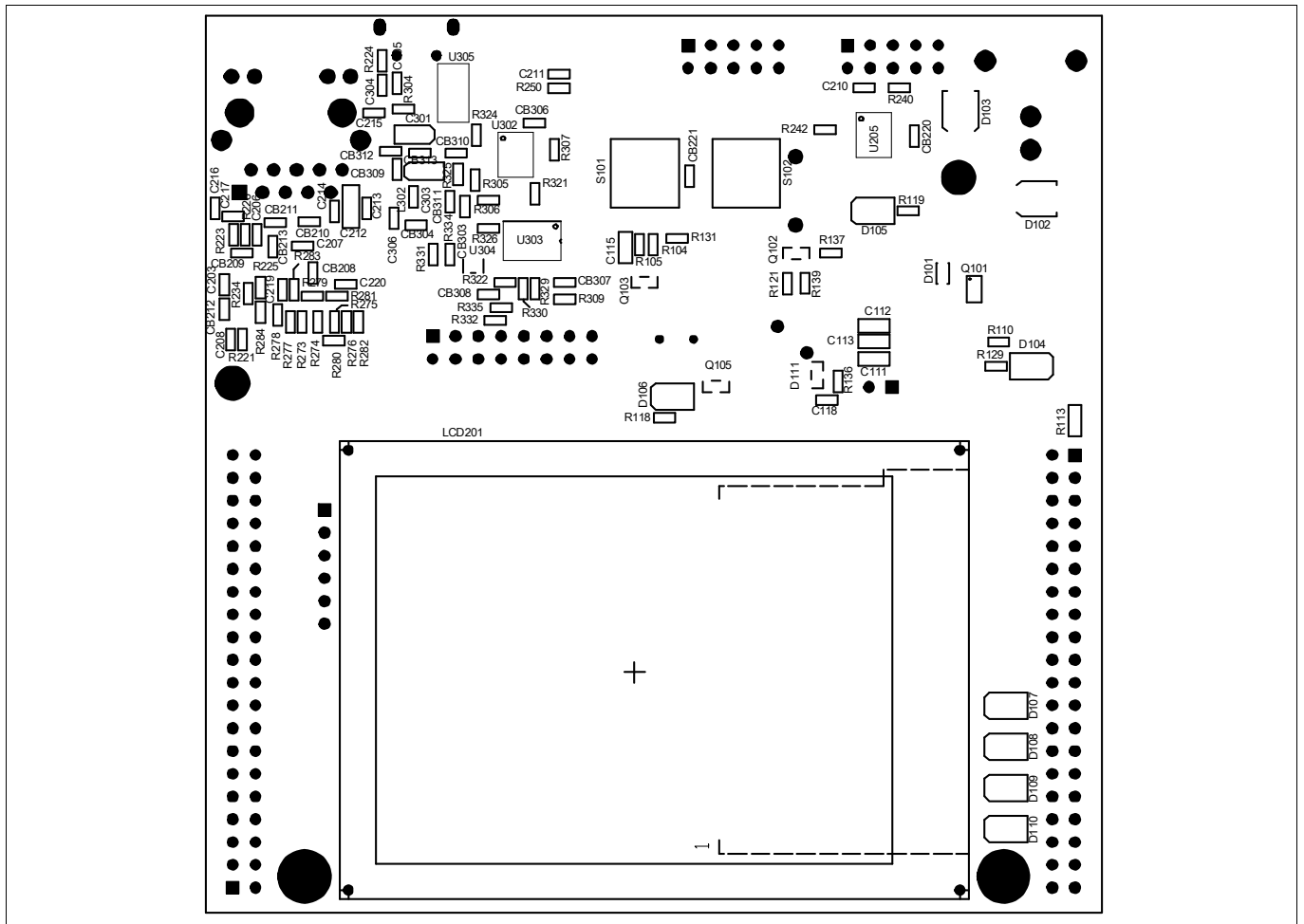

Figure 7-6 Component Plot Bottom Layer

## 7.4 Layout with Dimensioning

The following dimensions should be used for development of extension boards.

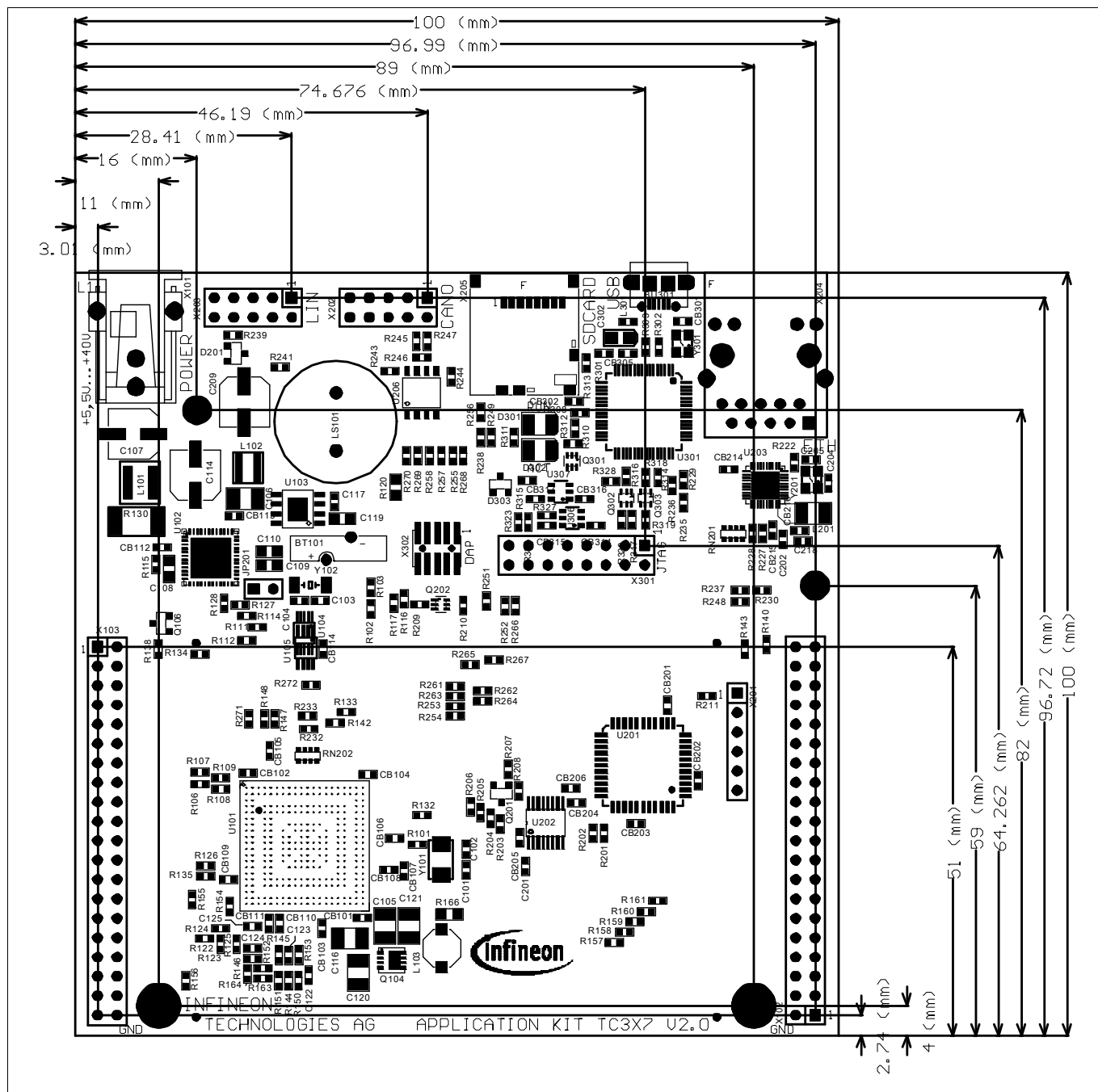

Figure 7-7 Dimensioning (mm)

Schematic and Layout

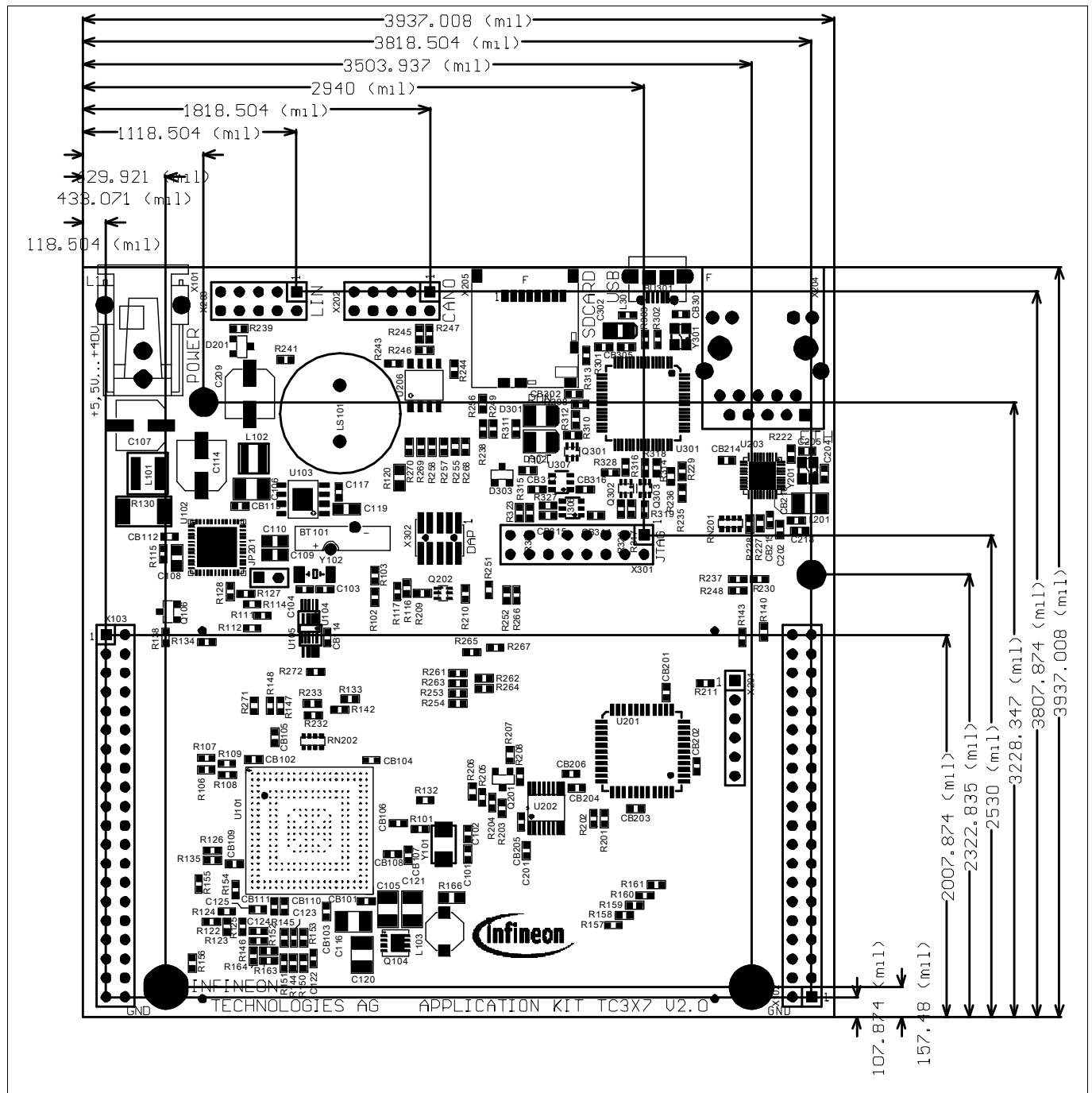

Figure 7-8 Dimensioning (mil)

The dimensioning is valid for all Application Kits.

---

**Revision History**

Page or Item	Subjects (major changes since previous revision)
<b>V2.0, 2018-06</b>	
all	Adapt to new board version V2.0 with Gigabit Ethernet



#### Trademarks of Infineon Technologies AG

$\mu$ HVIC™,  $\mu$ IPM™,  $\mu$ PFC™, AU-ConvertIR™, AURIX™, C166™, CanPAK™, CIPOS™, CIPURSE™, CoolDP™, CoolGaN™, COOLiR™, CoolMOS™, CoolSET™, CoolSiC™, DAVE™, DI-POL™, DirectFET™, DrBlade™, EasyPIM™, EconoBRIDGE™, EconoDUAL™, EconoPACK™, EconoPIM™, EiceDRIVER™, eupec™, FCOS™, GaNpowIR™, HEXFET™, HITFET™, HybridPACK™, iMOTION™, IRAM™, ISOFACE™, IsoPACK™, LEDriviR™, LITIX™, MIPAQ™, ModSTACK™, my-d™, NovalithIC™, OPTIGA™, OptiMOS™, ORIGA™, PowIRaudio™, PowIRstage™, PrimePACK™, PrimeSTACK™, PROFET™, PRO-SIL™, RASIC™, REAL3™, SmartLEWIS™, SOLID FLASH™, SPOC™, StrongIRFET™, SupIRBuck™, TEMPFET™, TRENCHSTOP™, TriCore™, UHVIC™, XHP™, XMC™.

Trademarks updated November 2015

#### Other Trademarks

All referenced product or service names and trademarks are the property of their respective owners.

**Edition 2018-06**

**Published by**

**Infineon Technologies AG**

**81726 Munich, Germany**

**© 2018 Infineon Technologies AG.**

**All Rights Reserved.**

**Do you have a question about any aspect of this document?**

**Email: [erratum@infineon.com](mailto:erratum@infineon.com)**

**Document reference**

**Doc\_Number**

#### IMPORTANT NOTICE

The information given in this document shall in no event be regarded as a guarantee of conditions or characteristics ("Beschaffheitsgarantie").

With respect to any examples, hints or any typical values stated herein and/or any information regarding the application of the product, Infineon Technologies hereby disclaims any and all warranties and liabilities of any kind, including without limitation warranties of non-infringement of intellectual property rights of any third party.

In addition, any information given in this document is subject to customer's compliance with its obligations stated in this document and any applicable legal requirements, norms and standards concerning customer's products and any use of the product of Infineon Technologies in customer's applications.

The data contained in this document is exclusively intended for technically trained staff. It is the responsibility of customer's technical departments to evaluate the suitability of the product for the intended application and the completeness of the product information given in this document with respect to such application.

For further information on technology, delivery terms and conditions and prices, please contact the nearest Infineon Technologies Office ([www.infineon.com](http://www.infineon.com)).

#### WARNINGS

Due to technical requirements products may contain dangerous substances. For information on the types in question please contact your nearest Infineon Technologies office.

Except as otherwise explicitly approved by Infineon Technologies in a written document signed by authorized representatives of Infineon Technologies, Infineon Technologies' products may not be used in any applications where a failure of the product or any consequences of the use thereof can reasonably be expected to result in personal injury.