

SUMMARY

Wires

Coax 1



Image is for illustrative purpose only

Series 3S
Termination type Male solder Coaxial
IP rating 50
AWG wire size 0.00 - 0.00
Cable Ø 9.80 - 10.50 mm
Status active
Matching parts [ERA.3S.250.CTL](#)

Download

[Request a quote](#)

[Catalog](#)

TECHNICAL DETAILS

Mechanics

Shell Style/Model FFA*: Straight plug, cable collet and nut for fitting a bend relief
Keying Circular, male
Housing Material Brass (chrome plated [SAE AMS 2460]) shell and collet nut, nickel plated [SAE AMS QQ N 290] brass latch sleeve and mid pieces
Variant Z : Nut for fitting a bend relief
Weight 58.41 g

Performance

Configuration 3S.250 : 1 Coax (50 Ohm)
Insulator T: PTFE
Rated Current 26 Amps

Specifications

Contact Type: Coaxial 50 Ohm (Solder)
Contact Dia.: 3 mm (0.118in)
Bucket Dia.: 2.7 mm (0.106in)
Vtest: 3000 V (AC), 4200 V (DC)
Impedance: 50 Ohm
VSWR: 1.06 + 0.5 * f /GHz

LEMO products and services are provided "as is". LEMO makes no warranties or representations with regard to LEMO product & services or use of them, express, implied or statutory, including for accuracy, completeness, or security. The user is fully responsible for his products and applications using LEMO components.

Cable type: RG 213/U, RG 115 A/U, RG 11 A/U, RG 144/U, RG 165 /U

Others

Endurance (Shell): 5000 mating cycles
Temp (min / max): -55°C / +250°C
Humidity (max): ≤95% [at 60 deg C / 140 F]
Vibration: 15 g [10 Hz - 2000 Hz]
Shock Resistance: 100 g [6 ms]
Climatical Category: 50/175/21
Shielding (min): 75 dB (10 MHz)
Shielding (min): 40 dB (1 GHz)
Salt Spray Corrosion: >144 hr

DRAWINGS

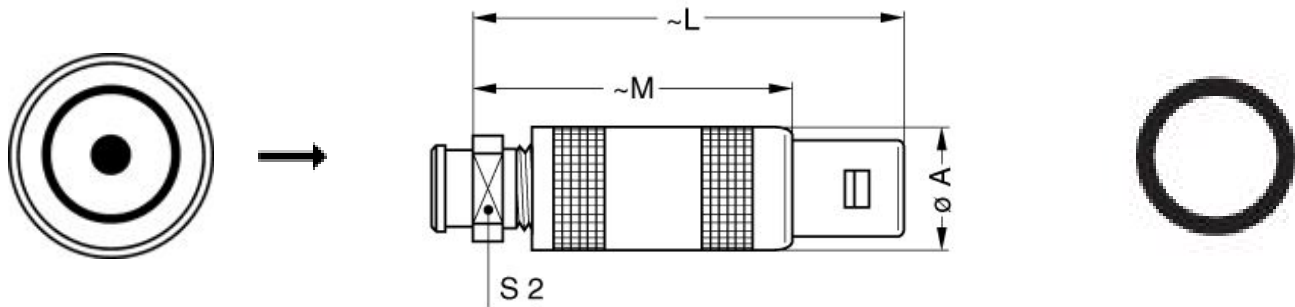

Dimensions

	A	L	M	S2
mm.	17.8	61	46	14
in.	0,70	2,40	1,81	0,55

RECOMMENDED BY LEMO

Tools

LEMO products and services are provided "as is". LEMO makes no warranties or representations with regard to LEMO product & services or use of them, express, implied or statutory, including for accuracy, completeness, or security. The user is fully responsible for his products and applications using LEMO components.

Spanner wrench:

[DCP.91.023.TN](#)

Cables

213000	PE	Black	
311100	PVC	Black	
CCX.50.RG2.13U10N	PE	Black	
CCX.75.RG0.11AU10N	PVC	Black	

LEMO products and services are provided "as is". LEMO makes no warranties or representations with regard to LEMO product & services or use of them, express, implied or statutory, including for accuracy, completeness, or security. The user is fully responsible for his products and applications using LEMO components.