

## Description:

This N-Channel MOSFET uses advanced SGT technology and design to provide excellent  $R_{DS(on)}$  with low gate charge.

It can be used in a wide variety of applications.

## Features:

- 1)  $V_{DS}=100V, I_D=60A, R_{DS(ON)} < 10m\ \Omega @ V_{GS}=10V$  (Typ:  $8.6m\ \Omega$ )
- 2) Low gate charge.
- 3) Green device available.
- 4) Advanced high cell density trench technology for ultra low  $R_{DS(ON)}$ .
- 5) Excellent package for good heat dissipation.
- 6) MSL3

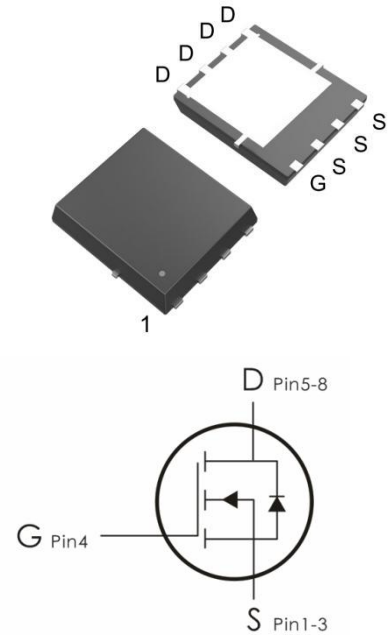

## Package Marking and Ordering Information:

Part NO.	Marking	Package	Packing
DON60N10-L	60N10-L	DFN5*6-8	5000 pcs/Reel

## Absolute Maximum Ratings: ( $T_C=25^\circ C$ unless otherwise noted)

Symbol	Parameter	Ratings	Units
$V_{DS}$	Drain-Source Voltage	100	V
$V_{GS}$	Gate-Source Voltage	$\pm 20$	V
$I_D$	Continuous Drain Current	60	A
	Continuous Drain Current- $T_C=100^\circ C$	42	
$P_D$	Power Dissipation	54	W
$I_{DM}$	Pulsed Drain Current <sup>1</sup>	240	A
$E_{AS}$	Single pulse avalanche energy <sup>2</sup>	71	mJ
$T_J, T_{STG}$	Operating and Storage Junction Temperature Range	-55-+150	$^\circ C$

## Thermal Characteristics:

Symbol	Parameter	Max	Units
$R_{\theta JC}$	Thermal Resistance, Junction to Case	2.3	$^\circ C/W$
$R_{\theta JA}$	Thermal Resistance, Junction to Ambient	60	$^\circ C/W$

**Electrical Characteristics:** ( $T_C=25^{\circ}\text{C}$  unless otherwise noted)

Symbol	Parameter	Conditions	Min	Typ	Max	Units
<b>Off Characteristics</b>						
$BV_{DSS}$	Drain-Source Breakdown Voltage	$V_{GS}=0V, I_D=250\ \mu\text{A}$	100	---	---	V
$I_{DSS}$	Zero Gate Voltage Drain Current	$V_{GS}=0V, V_{DS}=100V$	---	---	1	$\mu\text{A}$
$I_{GSS}$	Gate-Source Leakage Current	$V_{GS}=\pm 20V, V_{DS}=0A$	---	---	$\pm 100$	nA
<b>On Characteristics</b>						
$V_{GS(th)}$	Gate-Source Threshold Voltage	$V_{GS}=V_{DS}, I_D=250\ \mu\text{A}$	1	1.8	2.5	V
$R_{DS(on)}$	Drain-Source On Resistance <sup>3</sup>	$V_{GS}=10V, I_D=10A$	---	8.6	10	$\text{m}\Omega$
		$V_{GS}=4.5V, I_D=10A$	---	11	15	$\text{m}\Omega$
<b>Dynamic Characteristics</b>						
$C_{iss}$	Input Capacitance	$V_{DS}=50V, V_{GS}=0V, f=1\text{MHz}$	---	1615	---	pF
$C_{oss}$	Output Capacitance		---	441	--	
$C_{rss}$	Reverse Transfer Capacitance		---	7.8	---	
<b>Switching Characteristics</b>						
$t_{d(on)}$	Turn-On Delay Time	$V_{DD}=50V, R_D=5\ \Omega$ $R_{ENG}=10\ \Omega, V_{GS}=10V$	---	9.4	---	ns
$t_r$	Rise Time		---	4.2	---	ns
$t_{d(off)}$	Turn-Off Delay Time		---	25.2	---	ns
$t_f$	Fall Time		---	4.2	---	ns
$Q_g$	Total Gate Charge		$V_{GS}=10V, V_{DD}=50V,$ $I_D=20A$	---	31.5	---
$Q_{gs}$	Gate-Source Charge	---		3.1	---	nC
$Q_{gd}$	Gate-Drain "Miller" Charge	---		14.7	---	nC
<b>Drain-Source Diode Characteristics</b>						
$V_{SD}$	Diode Forward Voltage	$V_{GS}=0V, I_{SD}=20A$	---	0.9	1.3	V
$I_S$	Continuous Drain Current	$V_D=V_G=0V$	---	---	60	A
$I_{SM}$	Pulsed Drain Current		---	---	240	A

**Notes:**

1. Repetitive Rating: Pulse Width Limited by Maximum Junction Temperature
2. EAS condition:  $T_J=25^{\circ}\text{C}$ ,  $V_{DD}=50V$ ,  $V_G=10V$ ,  $L=0.5\text{mH}$
3. Pulse Test: Pulse Width $\leq 300\mu\text{s}$ , Duty Cycle $\leq 0.5\%$

Typical Characteristics: ( $T_c=25^\circ\text{C}$  unless otherwise noted)

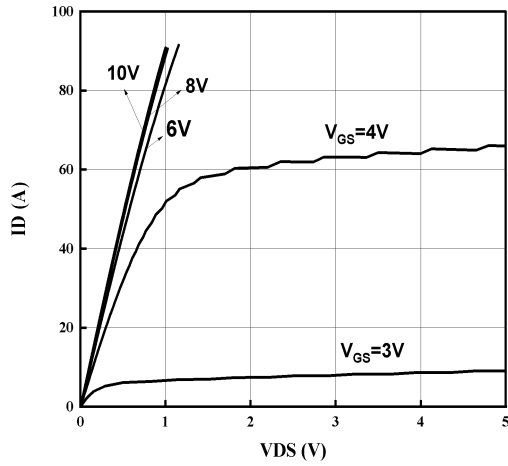

Fig1. Typical Output Characteristics

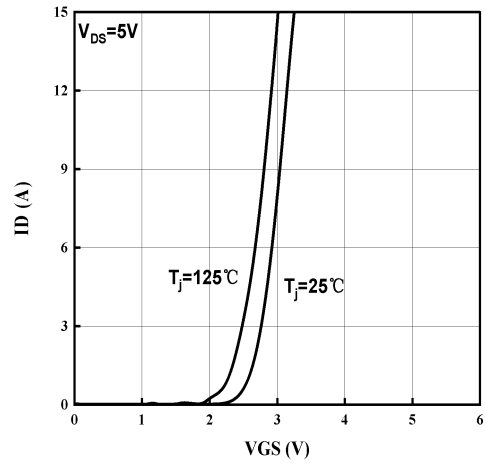

Fig2. Typical Transfer Characteristics

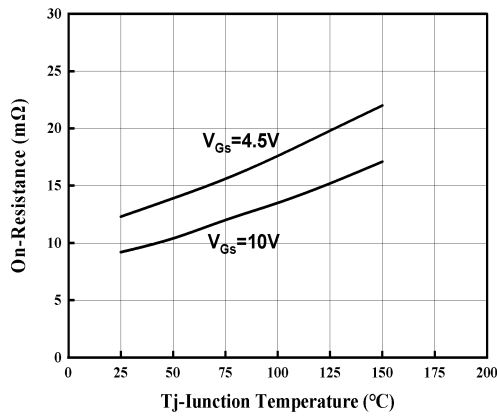

Fig3. On-Resistance Vs. Temperature

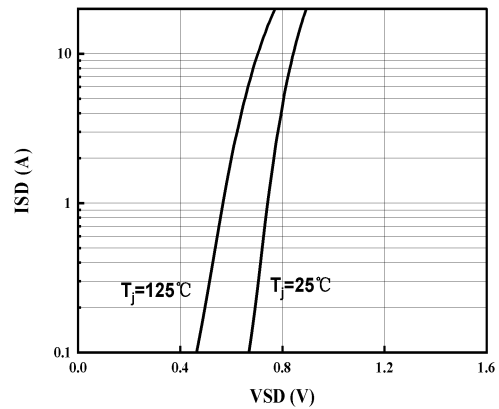

Fig4. Typical Source-Drain Diode Forward Voltage

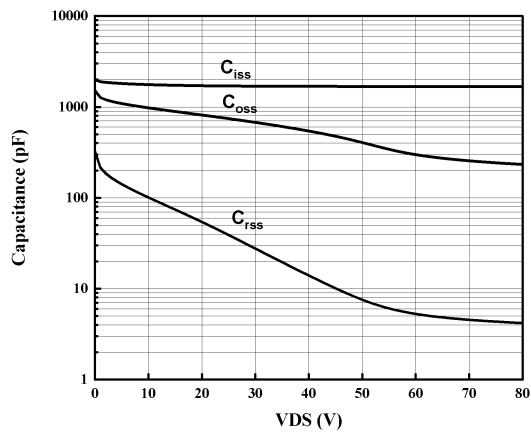

Fig5. Typical Capacitance

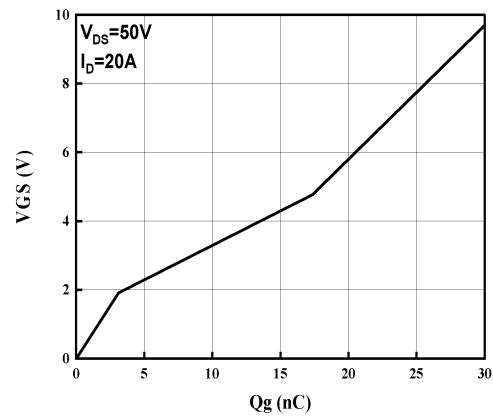

Fig6. Typical Gate Charge

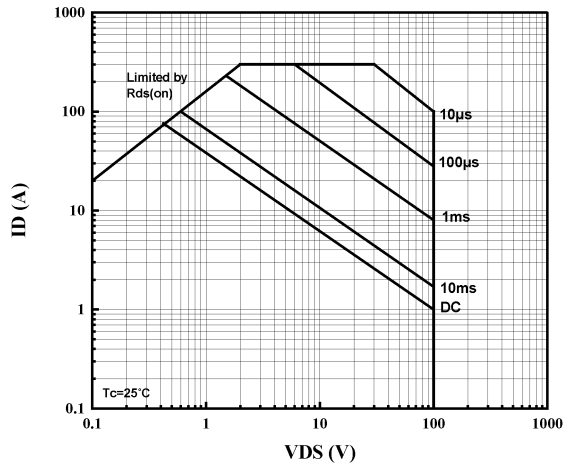

Fig7. Safe Operating Area

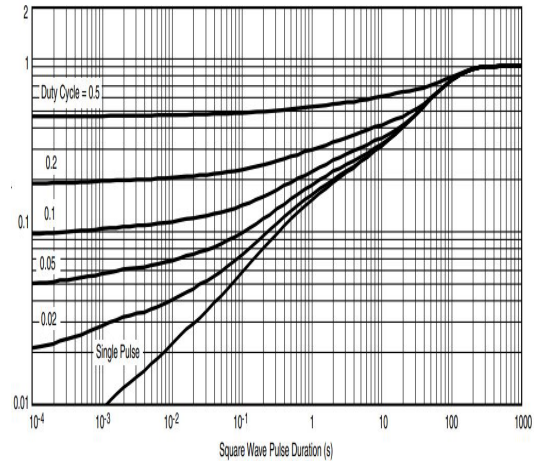
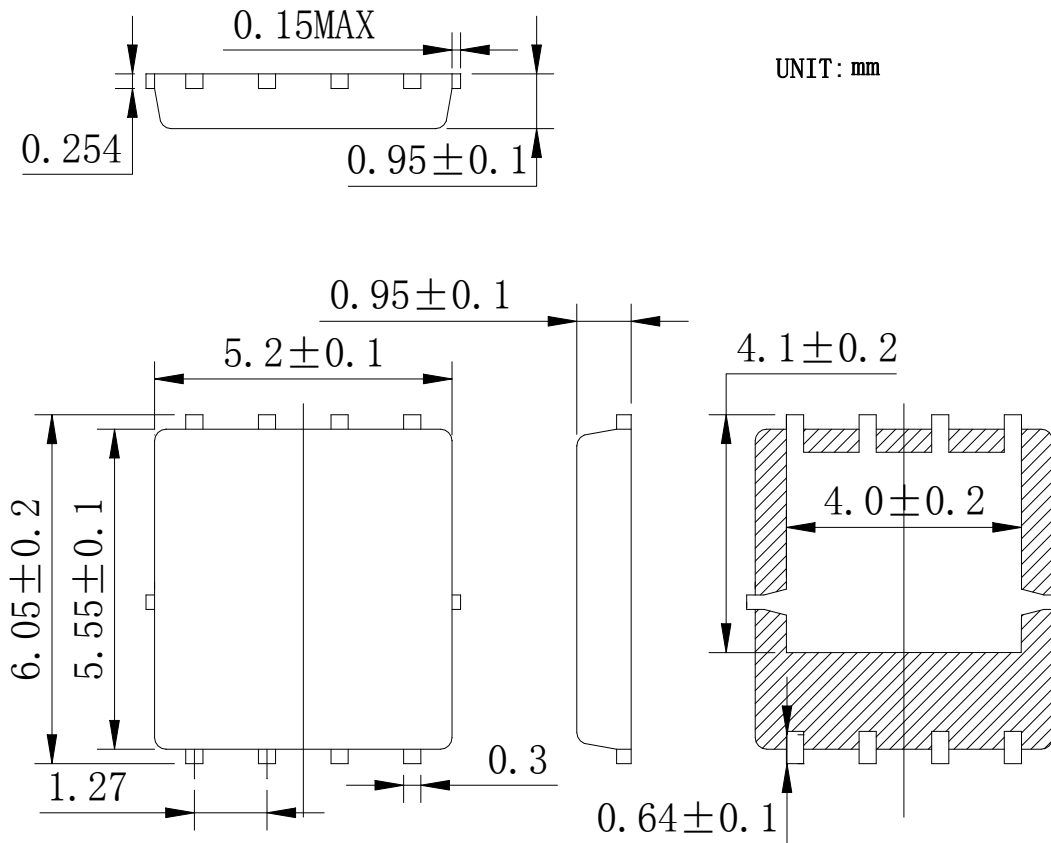

Fig8. Normalized transient thermal impedance

## DFN5x6-8 Package Information:



## Tape & Reel Information

Dimensions in mm

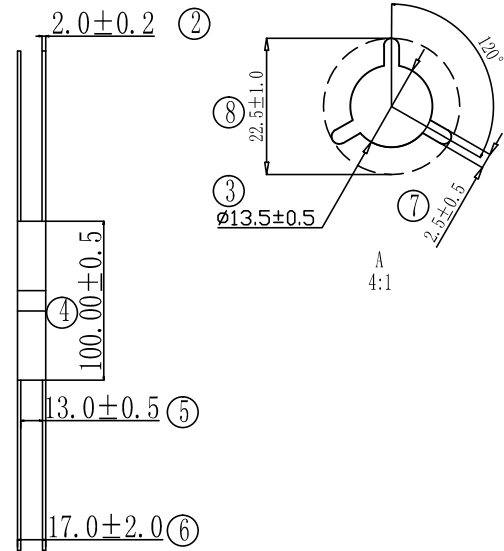
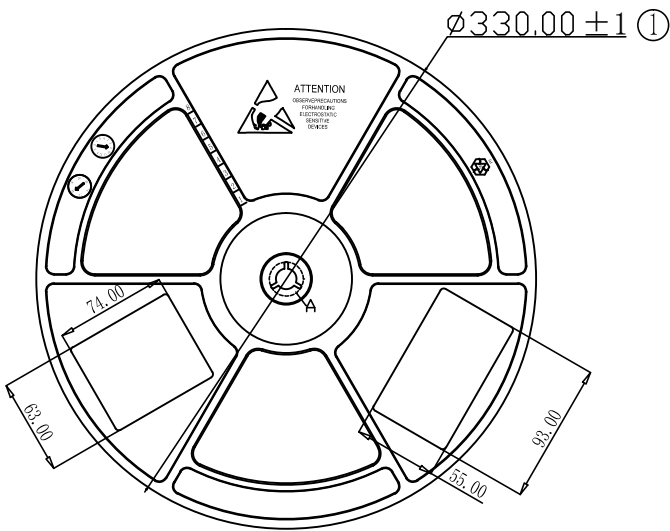

Symbol	A0	B0	K0	D0	D1	P0	P1	10*P0
Spec	$6.15 \pm 0.10$	$5.40 \pm 0.10$	$1.30 \pm 0.10$	$1.55 \pm 0.10$	$1.55 \pm 0.10$	$4.00 \pm 0.10$	$8.00 \pm 0.10$	$40.00 \pm 0.10$
Symbol	W	E	F	P2	t			
Spec	$12.00 \pm 0.10$	$1.75 \pm 0.10$	$5.50 \pm 0.10$	$2.00 \pm 0.10$	$0.20 \pm 0.05$			

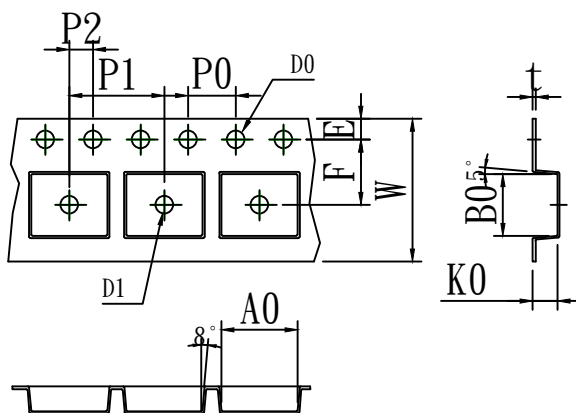

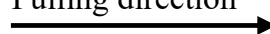
Pulling direction 

## Marking Information:

- ①. Doingter LOGO
- ②. Part NO.
- ③. Date Code(YWWG / R)

Y : Year Code , last digit of the year

WW : Week Code(01-53)

G/R : G(Green) /R(Lead Free)

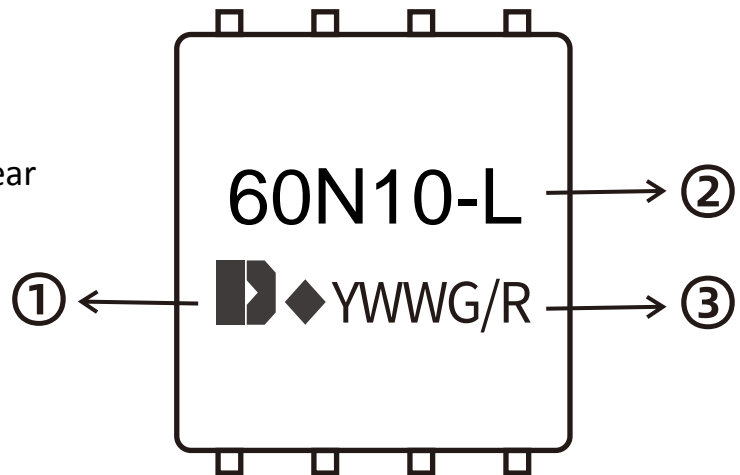

## Previous Version

Version	Date	Subjects (major changes since last revision)
1.0	2024-09-19	Release of final version

## Attention :

- Information furnished in this document is believed to be accurate and reliable. However, Shenzhen Doingter Semiconductor Co.,Ltd. assumes no responsibility for the consequences of use without consideration for such information nor use beyond it.
- Information mentioned in this document is subject to change without notice, apart from that when an agreement is signed, Shenzhen Doingter complies with the agreement. Products and information provided in this document have no infringement of patents.
- Shenzhen Doingter assumes no responsibility for any infringement of other rights of third parties which may result from the use of such products and information. This document supersedes and replaces all information previously supplied.  Is

a registered trademark of Shenzhen Doingter Semiconductor Co., Ltd. Copyright © 2013

Shenzhen Doingter Semiconductor Co.,Ltd. Printed All rights reserved.