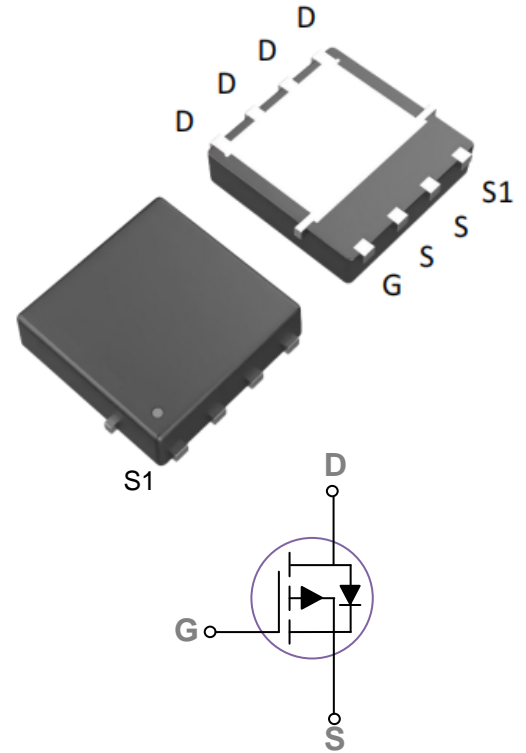


## Description:

This P-Channel MOSFET uses advanced trench technology and design to provide excellent  $R_{DS(on)}$  with low gate charge. It can be used in a wide variety of applications.

## Features:

- 1)  $V_{DS}=-30V, I_D=-60A, R_{DS(ON)}<7m\ \Omega @V_{GS}=-10V$
- 2) Low gate charge.
- 3) Green device available.
- 4) Advanced high cell density trench technology for ultra low  $R_{DS(ON)}$ .
- 5) Excellent package for good heat dissipation.



## Package Marking and Ordering Information:

Part NO.	Marking	Package	Packing
DOZ60P03	60P03	DFN3*3-8	5000 pcs/Reel

## Absolute Maximum Ratings: ( $T_c=25^\circ\text{C}$ unless otherwise noted)

Symbol	Parameter	Ratings	Units
$V_{DS}$	Drain-Source Voltage	-30	V
$V_{GS}$	Gate-Source Voltage	$\pm 20$	V
$I_D$	Continuous Drain Current	-60	A
	Continuous Drain Current- $T_c=100^\circ\text{C}$	-35	
$I_{DM}$	Pulsed Drain Current <sup>1</sup>	-240	
$P_D$	Power Dissipation	45	W
$E_{AS}$	Single pulse avalanche energy <sup>2</sup>	132	mJ
$T_J, T_{STG}$	Operating and Storage Junction Temperature Range	-55-+150	$^\circ\text{C}$

## Thermal Characteristics:

Symbol	Parameter	Max	Units
$R_{\theta JC}$	Thermal Resistance, Junction to Case	2.8	$^\circ\text{C}/\text{W}$

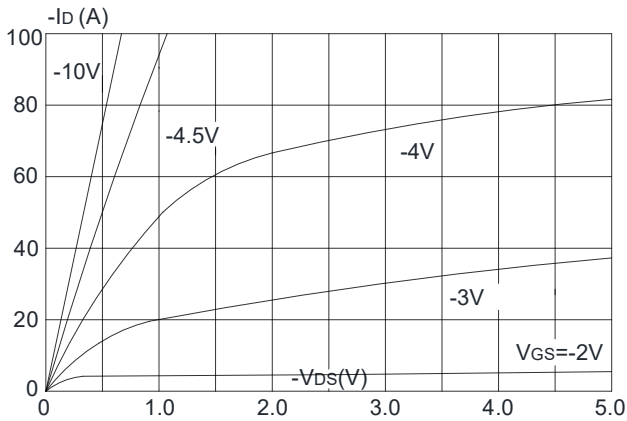
**Electrical Characteristics:** ( $T_c=25^\circ\text{C}$  unless otherwise noted)

Symbol	Parameter	Conditions	Min	Typ	Max	Units
<b>Off Characteristics</b>						
$BV_{DSS}$	Drain-Source Breakdown Voltage	$V_{GS}=0V, I_D=250\ \mu\text{A}$	-30	---	---	V
$I_{DSS}$	Zero Gate Voltage Drain Current	$V_{GS}=0V, V_{DS}=-30V$	---	---	-1	$\mu\text{A}$
$I_{GSS}$	Gate-Source Leakage Current	$V_{GS}=\pm 20V, V_{DS}=0A$	---	---	$\pm 100$	nA
<b>On Characteristics</b>						
$V_{GS(th)}$	Gate-Source Threshold Voltage	$V_{GS}=V_{DS}, I_D=250\ \mu\text{A}$	-1	-1.6	-2.5	V
$R_{DS(on)}$	Drain-Source On Resistance <sup>3</sup>	$V_{GS}=-10V, I_D=-30A$	---	5.5	7	$\text{m}\Omega$
		$V_{GS}=-4.5V, I_D=-20A$	---	7.8	10	$\text{m}\Omega$
<b>Dynamic Characteristics</b>						
$C_{iss}$	Input Capacitance	$V_{DS}=-15V, V_{GS}=0V, f=1\text{MHz}$	---	4550	---	pF
$C_{oss}$	Output Capacitance		---	525	--	
$C_{rss}$	Reverse Transfer Capacitance		---	480	---	
<b>Switching Characteristics</b>						
$t_{d(on)}$	Turn-On Delay Time	$V_{DS}=-15V, I_D=-30A,$ $R_{ENG}=2.5\ \Omega, V_{GS}=-10V$	---	19	---	ns
$t_r$	Rise Time		---	15	---	ns
$t_{d(off)}$	Turn-Off Delay Time		---	65	---	ns
$t_f$	Fall Time		---	36	---	ns
$Q_g$	Total Gate Charge	$V_{GS}=-10V, V_{DS}=-15V,$ $I_D=-40A$	---	45	---	nc
$Q_{gs}$	Gate-Source Charge		---	8	---	nc
$Q_{gd}$	Gate-Drain "Miller" Charge		---	12	---	nc
<b>Drain-Source Diode Characteristics</b>						
$V_{SD}$	Diode Forward Voltage	$V_{GS}=0V, I_{SD}=-30A$	---	-0.8	-1.2	V
$I_S$	Continuous Drain Current	$V_D=V_G=0V$	---	---	-60	A
$I_{SM}$	Pulsed Drain Current		---	---	-240	A

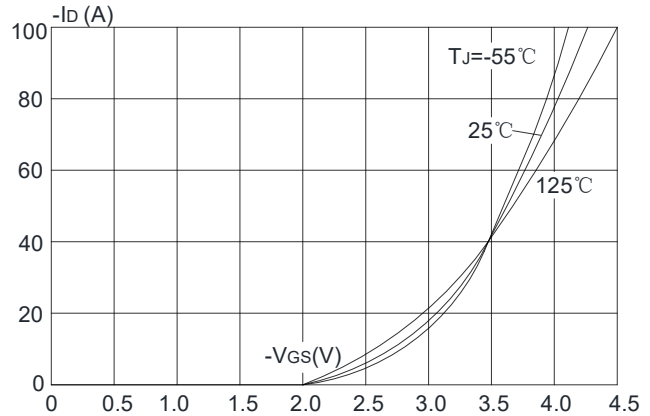
**Notes:**

1. Repetitive Rating: Pulse Width Limited by Maximum Junction Temperature
2.  $E_{AS}$  condition:  $T_J=25^\circ\text{C}$ ,  $V_{DD}=-15V$ ,  $V_G=-10V$ ,  $R_G=25\Omega$ ,  $L=0.5\text{mH}$ ,  $I_{AS}=-24A$
3. Pulse Test: Pulse Width $\leq 300\mu\text{s}$ , Duty Cycle $\leq 2\%$

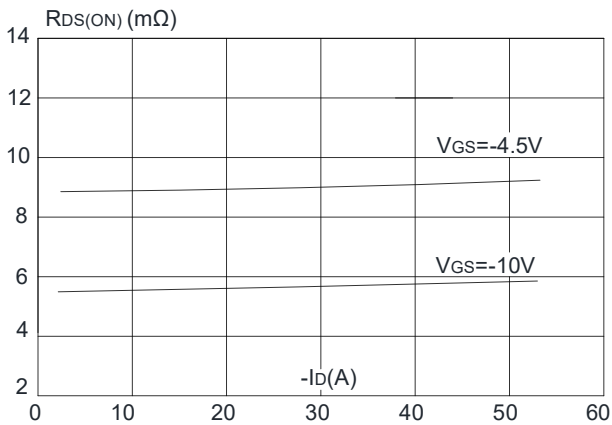
**Typical Characteristics:** ( $T_c=25^\circ\text{C}$  unless otherwise noted)



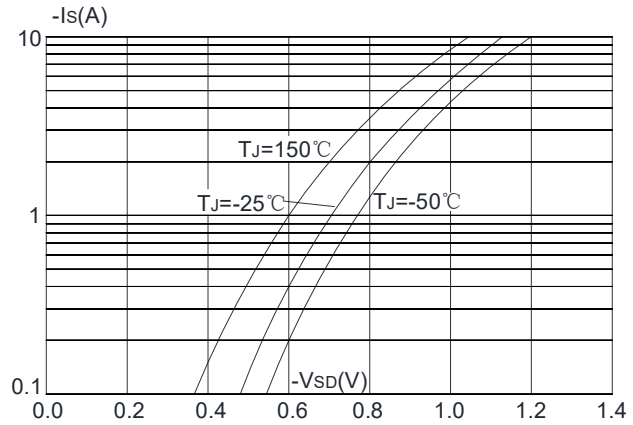
**Figure 1:** Output Characteristics



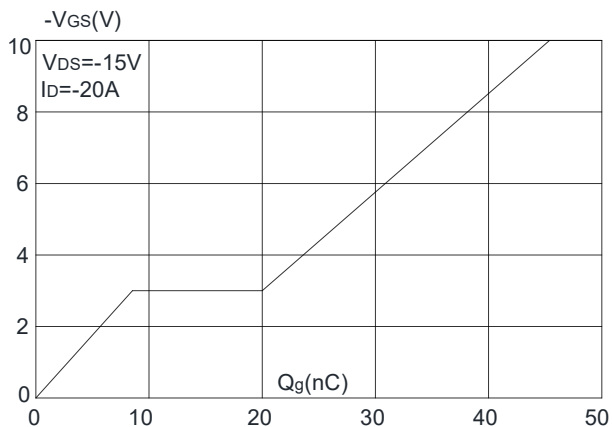
**Figure 2:** Typical Transfer Characteristics



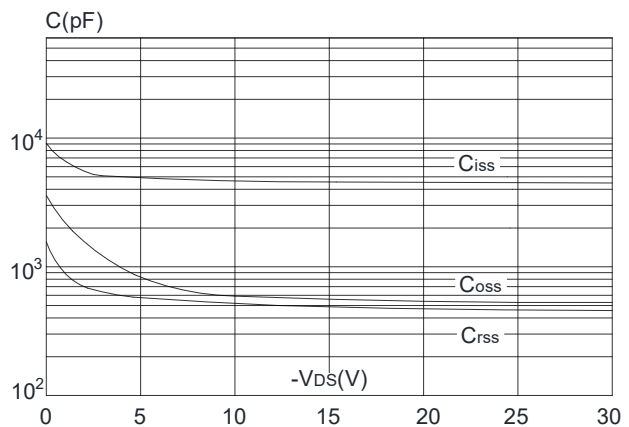
**Figure 3:** On-resistance vs. Drain Current



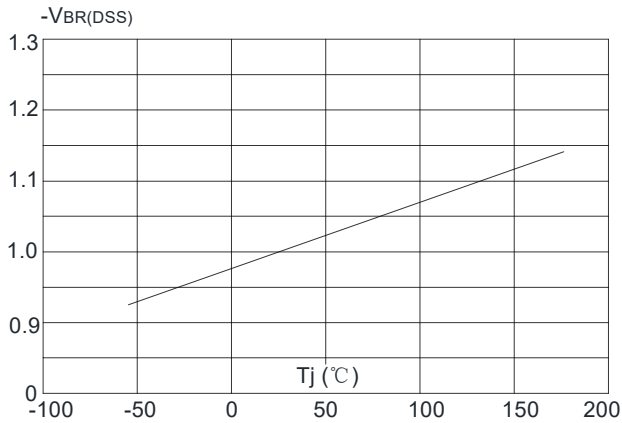
**Figure 4:** Body Diode Characteristics



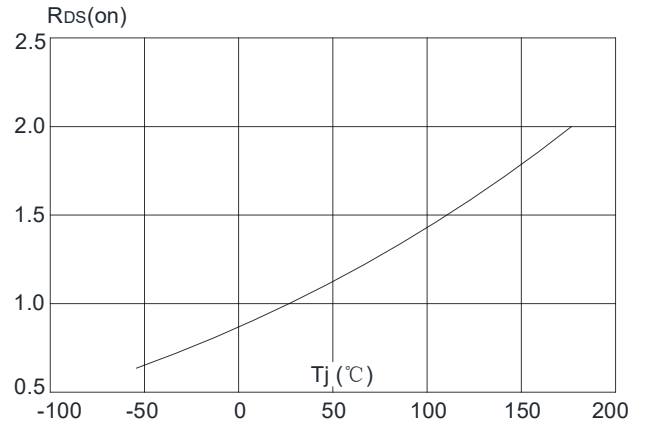
**Figure 5:** Gate Charge Characteristics



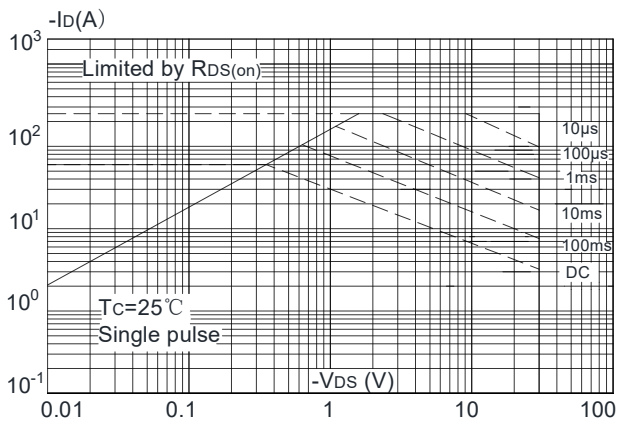
**Figure 6:** Capacitance Characteristics



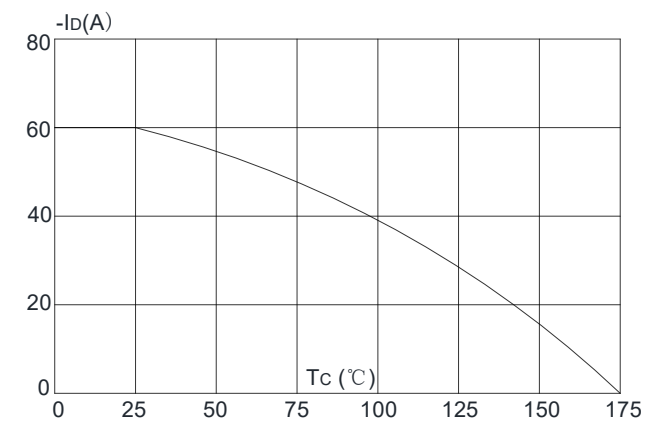
**Figure 7:** Normalized Breakdown Voltage vs. Junction Temperature



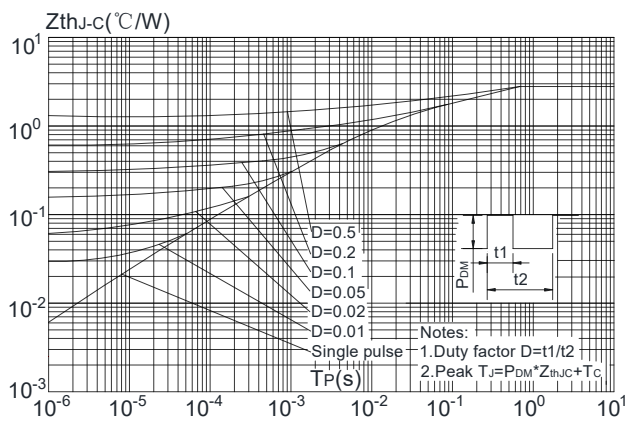
**Figure 8:** Normalized on Resistance vs. Junction Temperature



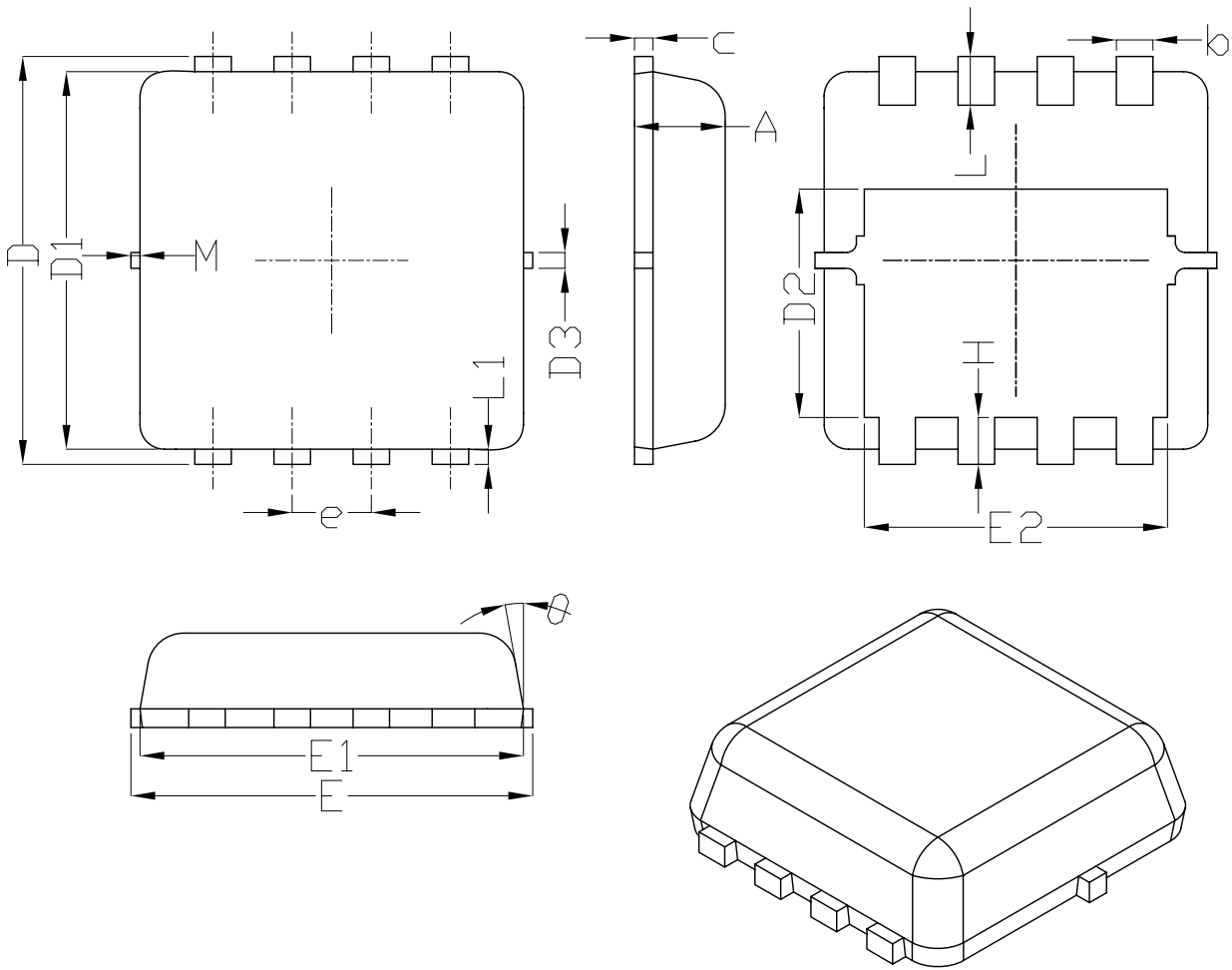
**Figure 9:** Maximum Safe Operating Area



**Figure 10:** Maximum Continuous Drain Current vs. Case Temperature

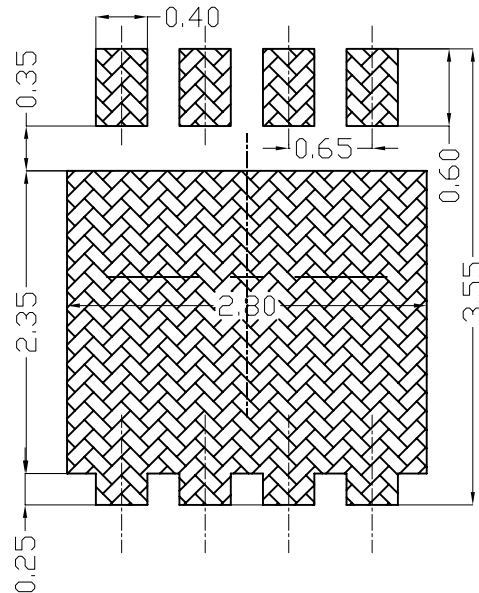


**Figure.11:** Maximum Effective Transient Thermal Impedance, Junction-to-Case

**DFN3X3-8 Package Information:**


SYMBOL	DIMENSIONAL REOMTS		
	MIN	NOM	MAX
A	0.70	0.75	0.80
b	0.25	0.30	0.35
c	0.10	0.15	0.25
D	3.25	3.35	3.45
D1	3.00	3.10	3.20
D2	1.78	1.88	1.98
D3	---	0.13	---
E	3.20	3.30	3.40
E1	3.00	3.15	3.20
E2	2.39	2.49	2.59
e	0.65BSC		
H	0.30	0.39	0.50
L	0.30	0.40	0.50
L1	---	0.13	---
$\theta$	---	10°	12°
M	*	*	0.15

\* Not specified


**UNIT: mm**

## Marking Information:

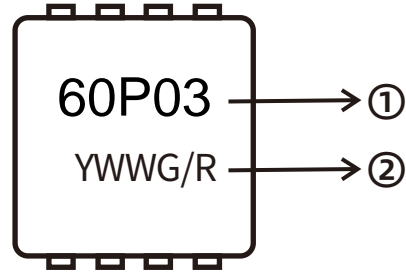
①. Part NO.

②. Date Code(YWWG / R)

Y : Year Code , last digit of the year

WW : Week Code(01-53)

G/R : G(Green) /R(Lead Free)



## Previous Version

Version	Date	Subjects (major changes since last revision)
1.0	2024-08-06	Release of final version

## Attention :

- Information furnished in this document is believed to be accurate and reliable. However, Shenzhen Doingter Semiconductor Co.,Ltd. assumes noresponsibility for the consequences of use without consideration for such information nor use beyond it.
- Information mentioned in this document is subject to change without notice, apart from that when an agreement is signed, Shenzhen Doingter complies with the agreement. Products and information provided in this document have no infringement of patents.
- Shenzhen Doingter assumes noresponsibility for any infringement of other rights of third parties which may result from the use of such products and information. This document supersedes and replaces all information previously supplied.



Is

a registered trademark of Shenzhen Doingter Semiconductor Co., Ltd. Copyright © 2013

Shenzhen DoingterSemiconductor Co.,Ltd. Printed All rights reserved.