

72A, 200V N-CHANNEL MOSFET

DESCRIPTION

SVT20240NT(P7)(S) is an N-channel enhancement mode power MOS field effect transistor which is produced using Silan's LVMOS technology. The improved process and cell structure have been especially tailored to minimize on-state resistance, provide superior switching performance.

This device is widely used in the fields of uninterruptible power supplies and power management of inverter systems.

FEATURES

- ◆ 72A, 200V, $R_{DS(on)(typ.)}=19.7m\Omega@V_{GS}=10V$
- ◆ Low gate charge
- ◆ Low C_{rss}
- ◆ Fast switching
- ◆ Improved dv/dt capability

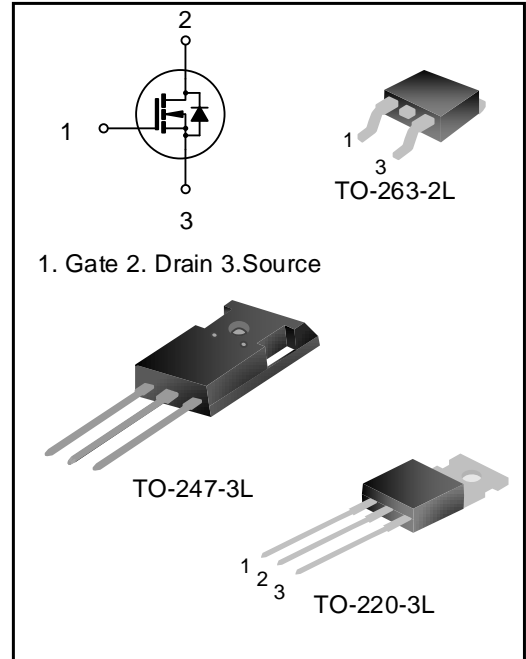

ORDERING INFORMATION

Part No.	Package	Marking	Hazardous Substance Control	Packing Type
SVT20240NT	TO-220-3L	20240NT	Pb free	Tube
SVT20240NP7	TO-247-3L	20240NP7	Pb free	Tube
SVT20240NS	TO-263-2L	20240NS	Halogen free	Tube
SVT20240NSTR	TO-263-2L	20240NS	Halogen free	Tape&Reel

ABSOLUTE MAXIMUM RATINGS (UNLESS OTHERWISE NOTED, $T_J=25^{\circ}C$)

Characteristics	Symbol	Ratings		Unit
		SVT20240NT/S	SVT20240NP7	
Drain-Source Voltage	V_{DS}	200		V
Gate-Source Voltage	V_{GS}	± 30		V
Drain Current	$T_C=25^{\circ}C$	72		A
	$T_C=100^{\circ}C$	51		
Drain Current Pulsed	I_{DM}	288		A
Power Dissipation ($T_C=25^{\circ}C$) -Derate above $25^{\circ}C$	P_D	263	348	W
		1.5	2.3	
Single Pulsed Avalanche Energy (Note 1)	E_{AS}	221		mJ
Operation Junction Temperature Range	T_J	-55~+175		$^{\circ}C$
Storage Temperature Range	T_{stg}	-55~+175		$^{\circ}C$

THERMAL CHARACTERISTICS

Characteristics	Symbol	Ratings		Unit
		SVT20240NT/S	SVT20240NP7	
Thermal Resistance, Junction-to-Case	$R_{\theta JC}$	0.57	0.43	$^{\circ}\text{C/W}$
Thermal Resistance, Junction-to-Ambient	$R_{\theta JA}$	62.5	50	$^{\circ}\text{C/W}$

ELECTRICAL CHARACTERISTICS (UNLESS OTHERWISE NOTED, $T_J=25^{\circ}\text{C}$)

Characteristics	Symbol	Test conditions	Min.	Typ.	Max.	Unit
Drain-Source Breakdown Voltage	BV_{DSS}	$V_{GS}=0V, I_D=250\mu A$	200	--	--	V
Drain-Source Leakage Current	I_{DSS}	$V_{DS}=200V, V_{GS}=0V$	--	--	1.0	μA
Gate-Source Leakage Current	I_{GSS}	$V_{GS}=\pm 20V, V_{DS}=0V$	--	--	± 100	nA
Gate Threshold Voltage	$V_{GS(th)}$	$V_{GS}=V_{DS}, I_D=250\mu A$	3	--	5	V
Static Drain- Source On State Resistance	$R_{DS(on)}$	$V_{GS}=10V, I_D=46A$	--	19.7	--	m Ω
Gate resistance	R_G	$f=1\text{MHz}$	--	1.7	--	Ω
Input Capacitance	C_{iss}	$f=1\text{MHz}, V_{GS}=0V,$ $V_{DS}=25V$	--	4434	--	pF
Output Capacitance	C_{oss}		--	459	--	
Reverse Transfer Capacitance	C_{rss}		--	182	--	
Turn-on Delay Time	$t_{d(on)}$	$V_{DD}=100V, V_{GS}=10V,$ $R_G=2.5\Omega, I_D=46A$ (Notes 2, 3)	--	28	--	ns
Turn-on Rise Time	t_r		--	44	--	
Turn-off Delay Time	$t_{d(off)}$		--	48	--	
Turn-off Fall Time	t_f		--	23	--	
Total Gate Charge	Q_g	$V_{DD}=160V, V_{GS}=10V, I_D=46A$ (Notes 2, 3)	--	88	--	nC
Gate-Source Charge	Q_{gs}		--	30	--	
Gate-Drain Charge	Q_{gd}		--	33	--	

SOURCE-DRAIN DIODE RATINGS AND CHARACTERISTICS

Characteristics	Symbol	Test conditions	Min.	Typ.	Max.	Unit
Continuous Source Current	I_S	Integral Reverse P-N Junction	--	--	72	A
Pulsed Source Current	I_{SM}	Diode in the MOSFET	--	--	288	
Diode Forward Voltage	V_{SD}	$I_S=46A, V_{GS}=0V$	--	--	1.3	V
Reverse Recovery Time	T_{rr}	$I_S=46A, V_{GS}=0V, V_R=50V,$	--	105	--	ns
Reverse Recovery Charge	Q_{rr}	$dI_F/dt=100A/\mu s$ (Note 2)	--	0.44	--	μC

Notes:

- $L=0.5\text{mH}, V_{DD}=100V, R_G=25\Omega,$ starting $T_J=25^{\circ}\text{C}$;
- Pulse Test: Pulse width $\leq 300\mu s,$ Duty cycle $\leq 2\%$;
- Essentially independent of operating temperature.

TYPICAL CHARACTERISTICS

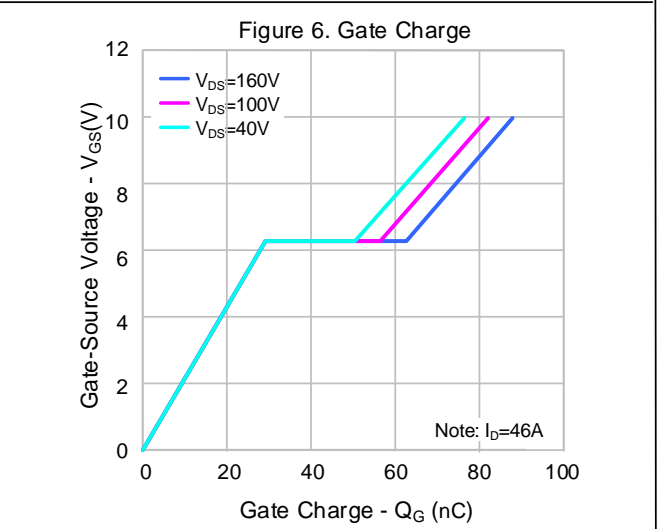
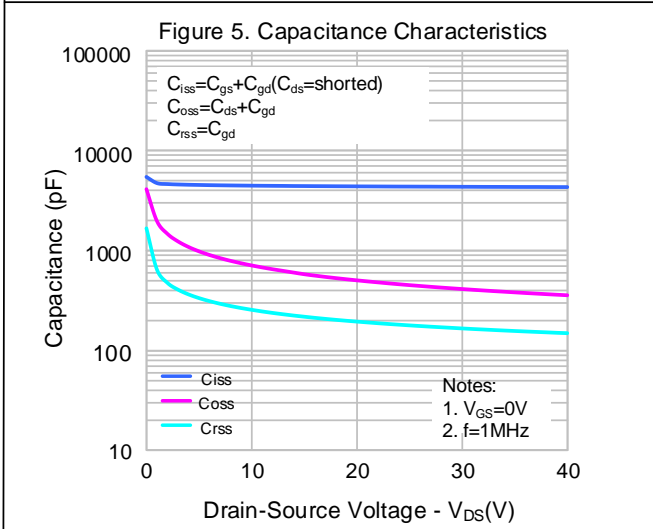
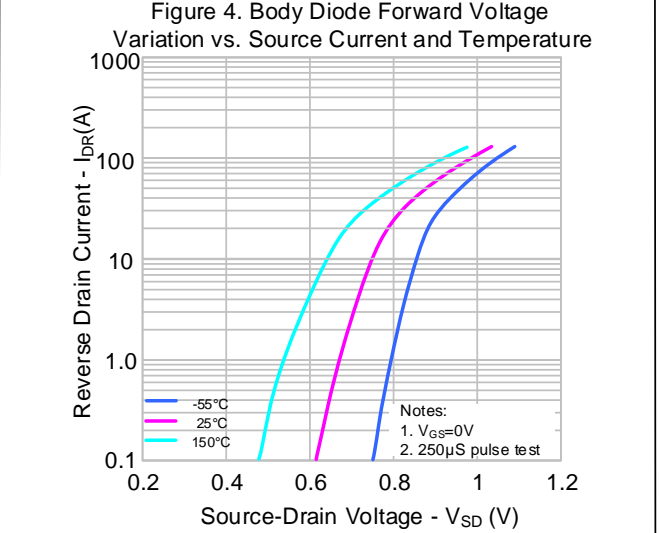
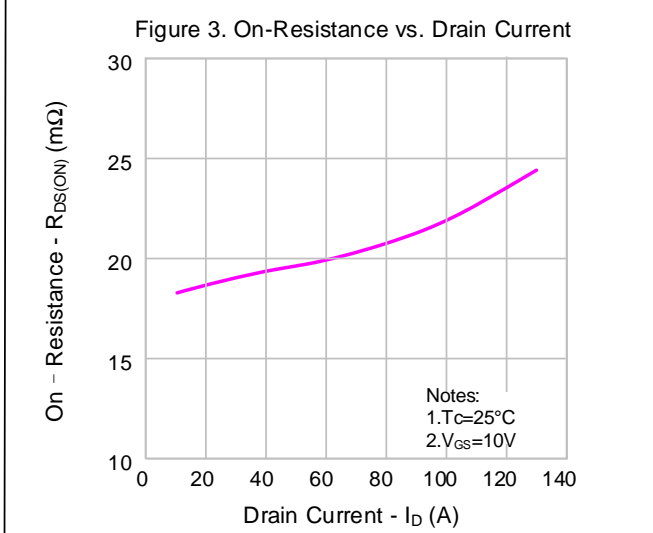
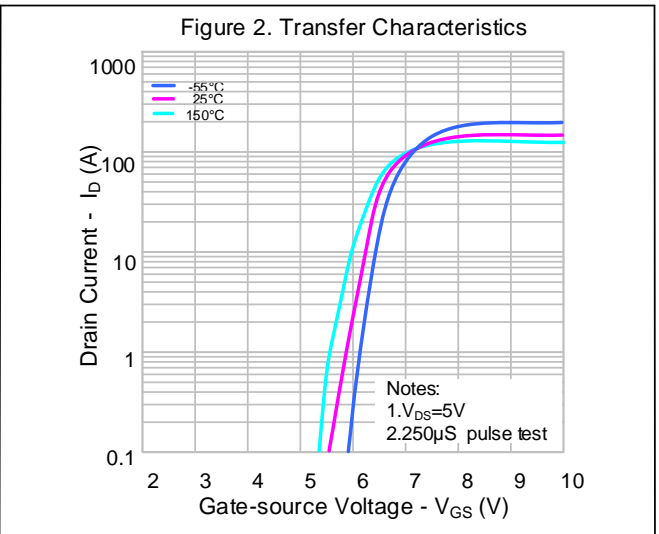
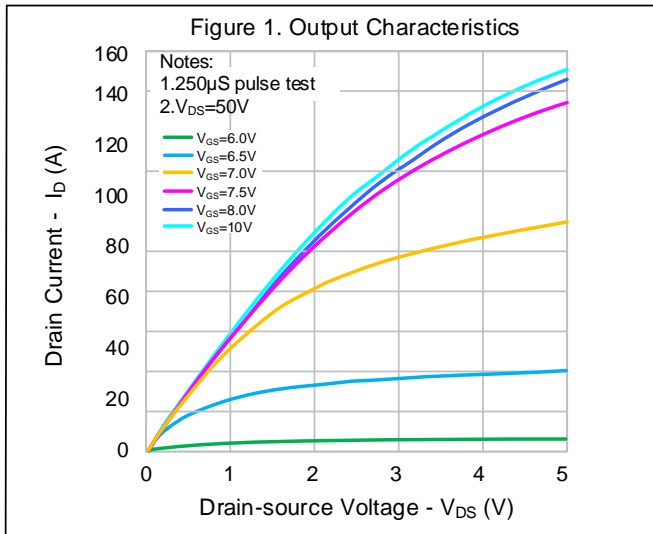

TYPICAL CHARACTERISTICS(CONTINUED)

Figure 7. Breakdown Voltage vs. Temperature Characteristics

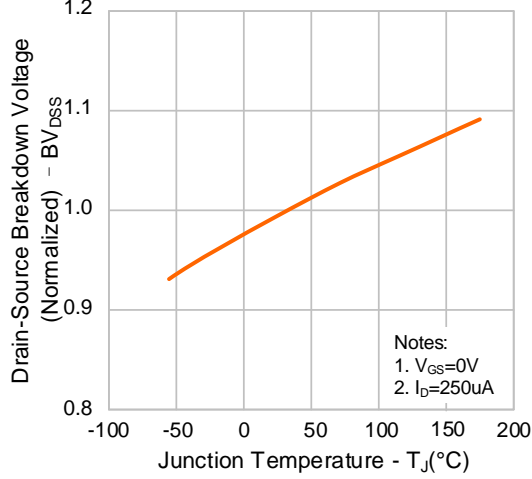

Figure 8. On-Resistance vs. Temperature Characteristics

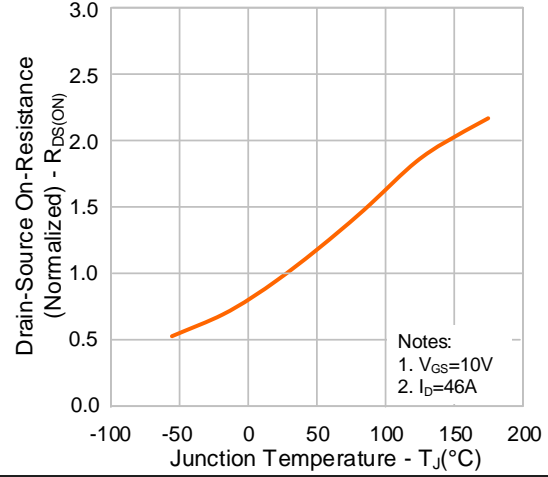

Figure 9-1. Max. Safe Operating Area(SVT20240NT/S)

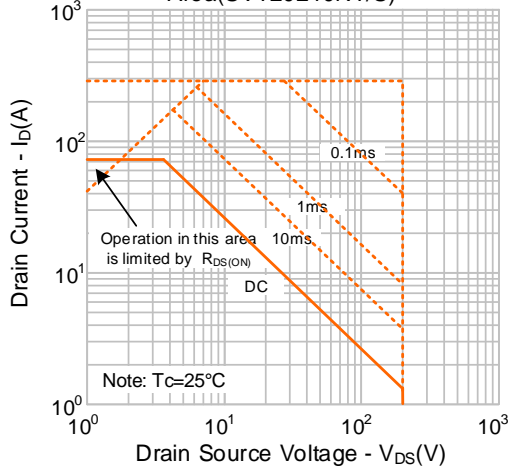
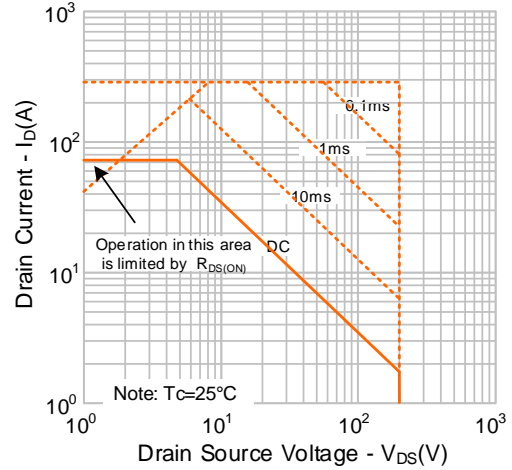
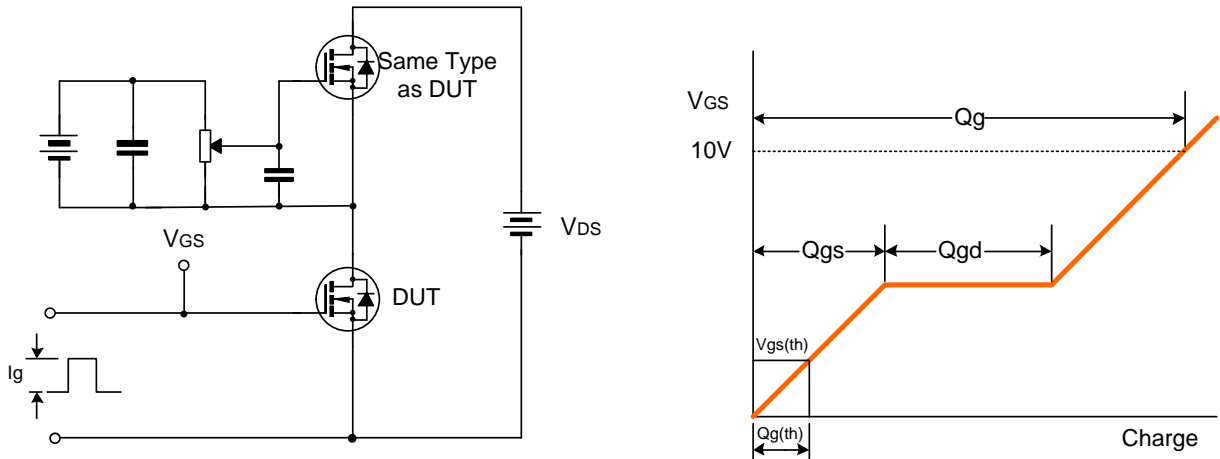

Figure 9-2. Max. Safe Operating Area(SVT20240NP7)



TYPICAL TEST CIRCUIT

Gate Charge Test Circuit & Waveform



Resistive Switching Test Circuit & Waveform

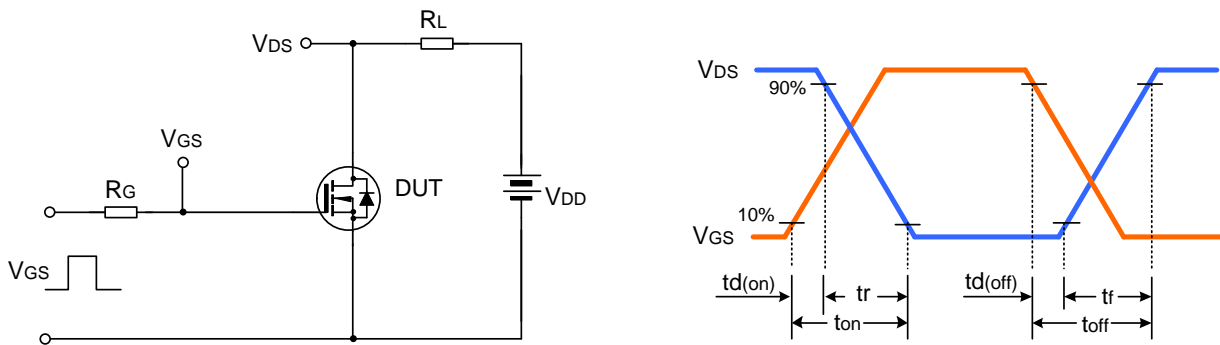

Unclamped Inductive Switching Test Circuit & Waveform

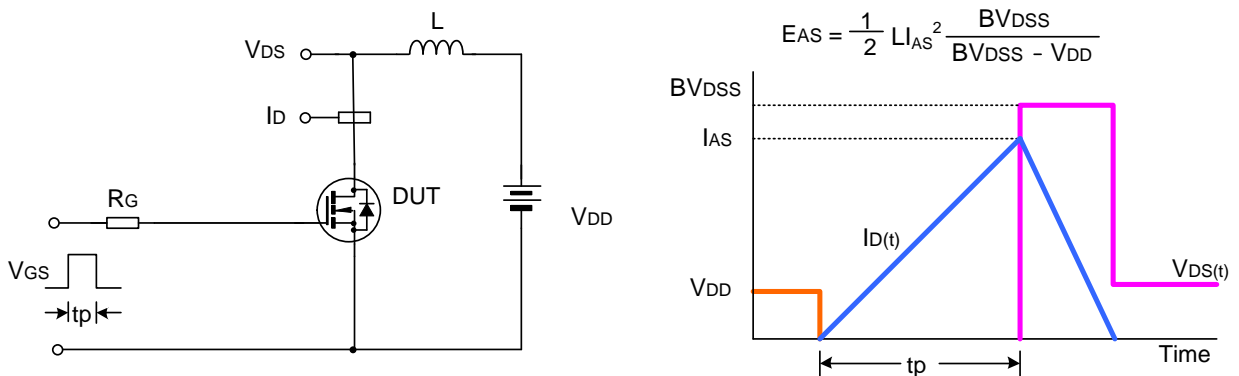

PACKAGE OUTLINE

TO-220-3L **UNIT: mm**

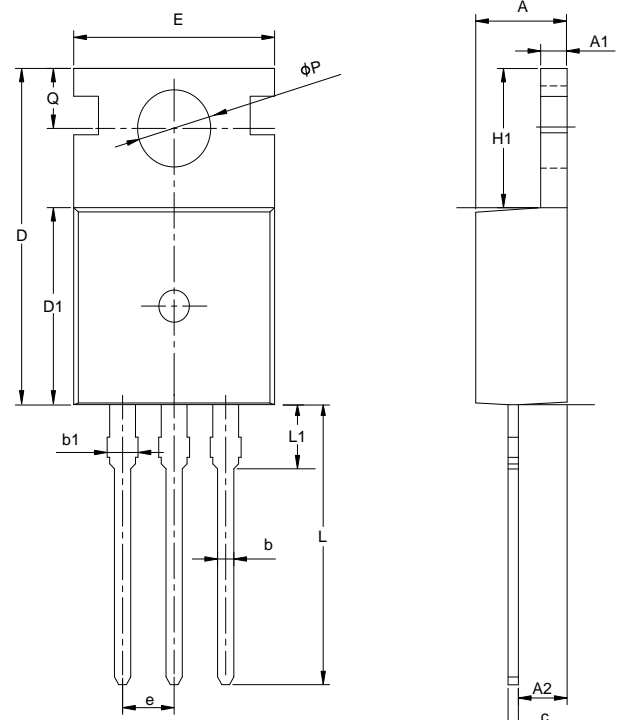

SYMBOL	MILLIMETER		
	MIN	NOM	MAX
A	4.30	4.50	4.70
A1	1.00	1.30	1.50
A2	1.80	2.40	2.80
b	0.60	0.80	1.00
b1	1.00	—	1.60
c	0.30	—	0.70
D	15.10	15.70	16.10
D1	8.10	9.20	10.00
E	9.60	9.90	10.40
e	2.54BSC		
H1	6.10	6.50	7.00
L	12.60	13.08	13.60
L1	—	—	3.95
φP	3.40	3.70	3.90
Q	2.60	—	3.20

TO-247-3L **UNIT: mm**

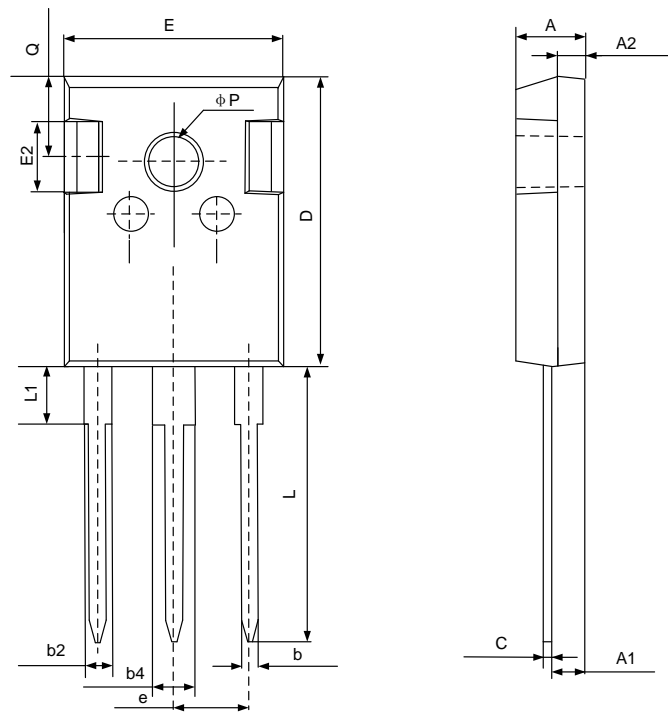

SYMBOL	MILLIMETER		
	MIN	NOM	MAX
A	4.80	5.00	5.20
A1	2.21	2.41	2.59
A2	1.85	2.00	2.15
b	1.11	—	1.36
b2	1.91	—	2.25
b4	2.91	—	3.25
c	0.51	—	0.75
D	20.80	21.00	21.30
E	15.50	15.80	16.10
E2	4.40	5.00	5.20
e	5.44 BSC		
L	19.72	19.92	20.22
L1	—	—	4.30
Q	5.60	5.80	6.00
P	3.40	—	3.80

PACKAGE OUTLINE (CONTINUED)

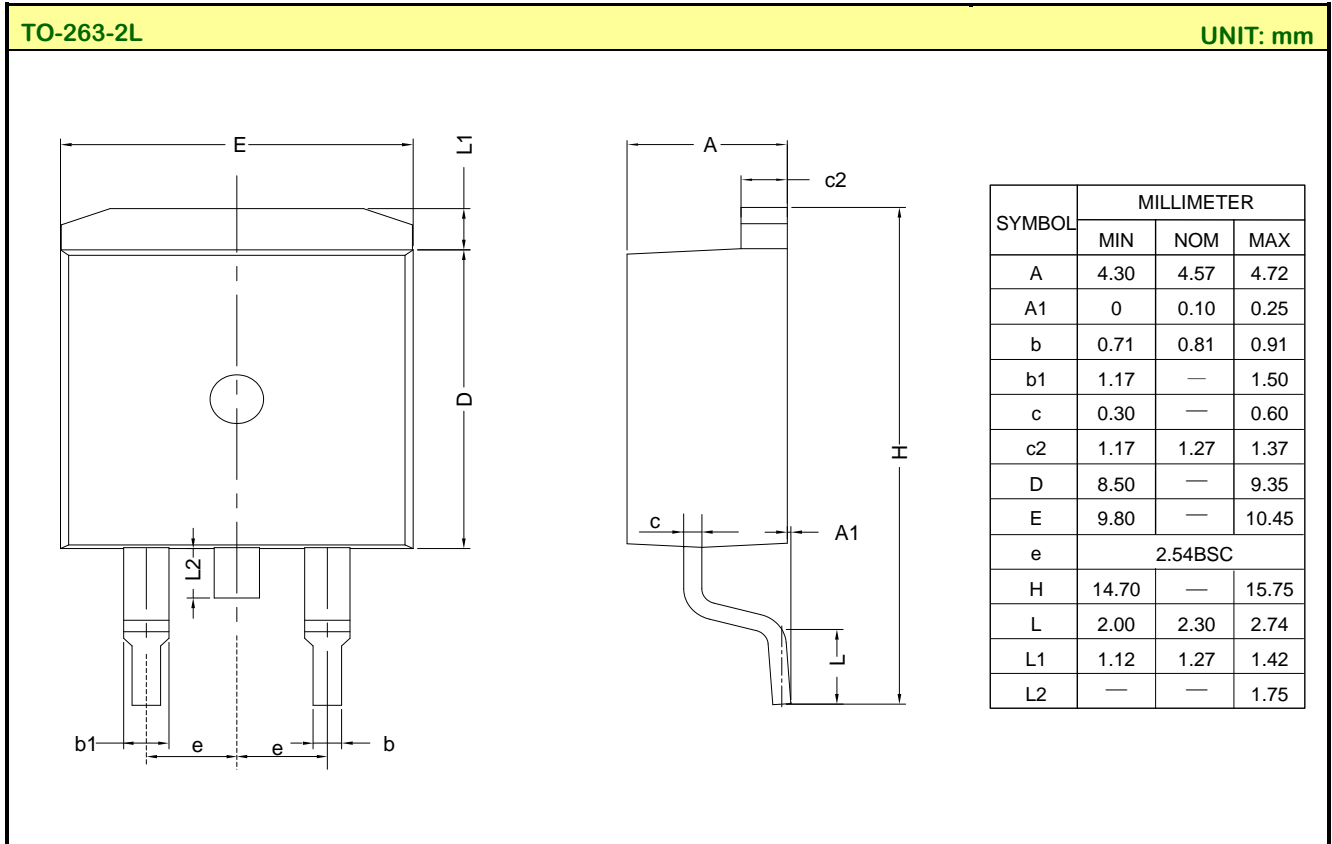

Important notice :

1. The instructions are subject to change without notice !
2. Customers should obtain the latest relevant information before placing orders and should verify that such information is complete and current. Please read the instructions carefully before using our products, including the circuit operation precautions.
3. Our products are consumer electronic products or the other civil electronic products.
4. When using our products, please do not exceed the maximum rating of the products, otherwise the reliability of the whole machine will be affected. There is a certain possibility of failure or malfunction of any semiconductor product under specific conditions. The buyer is responsible for complying with safety standards and taking safety measures when using our products for system design, sample and whole machine manufacturing, so as to avoid potential failure risk that may cause personal injury or property loss.
5. It is strongly recommended to identify the trademark when buying our products. Please contact us if there is any question.
6. Product promotion is endless, our company will wholeheartedly provide customers with better products!
7. Website: <http://www.silan.com.cn>

Part No.: SVT20240NT(P7)(S) Document Type: Datasheet
Copyright: HANGZHOU SILAN MICROELECTRONICS CO.,LTD Website: <http://www.silan.com.cn>

Rev.: 1.2

Revision History:

1. Add package of SVT20240NS(TO-263-2L)
 2. Update characteristics and figure 5, figure 6
 3. Update package outline of TO-247-3L
 4. Update important notice
-

Rev.: 1.1

Revision History:

1. Update characteristics
 2. Update Fig5 and 6
-

Rev.: 1.0

Revision History:

1. First release
-