

**Description**

UMW IR4427STR is power switch driver. It has a matching rise and fall time when charging and discharging the gate of the power switch.

UMW IR4427STR has high latch resistance under all conditions in its rated power and voltage range. When noise spikes of up to 5V (either polarity) occur on the ground pin, the IR4427STR is not damaged. IR4427STR can accept reverse currents up to 500 mA to force back its output without damage or logic confusion. All ports are fully protected by up to 2.0 kV electrostatic discharge (ESD).

**Applications**

- Switch-Mode Power Supplies
- line drivers
- Pulse transformer driver
- Driving MOSFETs and IGBTs
- Motor drives
- pulse generator
- Switch-Mode Power Supplies
- DC-to-DC Converters
- class D switching amplifier

**Features**

- Latch Protection: withstand 0.5 A reverse current
- Ability to Handle Negative Voltages (-10 V) at Inputs
- Low Output Impedance
- Two Independent Gate-Drive Channel
- 2-A Peak Output Current
- 4.5 to 25-V Single-Supply Range
- High Ability of driving capacitive load
- Rise/Fall time matching
- Operating Temperature Range of -40 to 125° C
- Turn on/Turn off Delays: 30ns

**Pin Configuration**

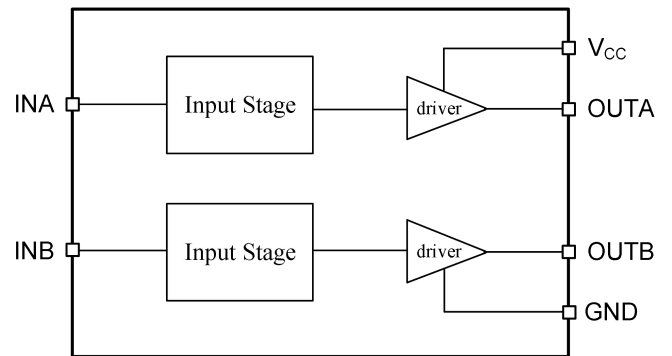

Pin Configuration and Functions

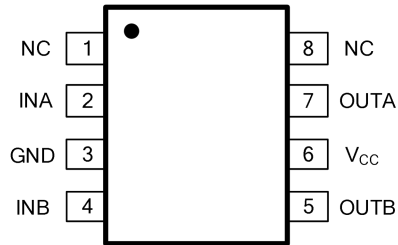

Figure7-1 8-Pin SOIC8 Top view

Table7-1 Lead Definitions

PIN	NAME	DESCRIPTION
1	NC	--
2	INA	Input to Channel A
3	GND	Ground: All signals are referenced to this pin.
4	INB	Input to Channel B
5	OUTB	Output of Channel B
6	V <sub>CC</sub>	Bias supply input
7	OUTA	Output of Channel A
8	NC	--

**Dual 2A Peak High-Speed Low-Side Power-MOSFET Drivers**
**Absolute Maximum Ratings**

Stresses beyond those listed under Absolute Maximum Ratings may cause permanent damage to the device. All voltages are with respect to GND unless otherwise noted, Currents are positive into, negative out of the specified terminal, environment temperature is 25 °C.

Symbol	Definition	MIN	MAX	UNIT
V <sub>CC</sub>	Supply voltage range	—	25	V
V <sub>IN</sub>	INA, INB voltage	GND-5	V <sub>CC</sub> +0.3	
	Human body model (HBM)	—	2000	V
	Charged device model (CDM)	—	500	V
PD	SOIC package power (TA ≤ 70°C)	—	470	mW
T <sub>J</sub>	Operating junction temperature	—	+150	°C
T <sub>S</sub>	Storage temperature	-45	+150	
V <sub>CC</sub>	Supply voltage range	4.8	20	V
T <sub>C</sub>	ambient temperature	-40	125	°C

**Electrical characteristics**

T<sub>A</sub> = 25°C, 4.5V ≤ V<sub>CC</sub> ≤ 18V (unless otherwise noted)

Symbol	Definition	MIN	TYP	MAX	UNIT
V <sub>IH</sub>	Input signal high threshold	2.4	—	—	V
V <sub>IL</sub>	Input signal low threshold	—	—	0.8	V
I <sub>IN</sub>	Input current (V <sub>IN</sub> =5V)	—	50	100	μA
V <sub>OH</sub>	High output voltage	V <sub>CC</sub> - 0.025	—	—	V
V <sub>OL</sub>	Low output voltage	—	—	0.025	V
R <sub>OH</sub>	Output pullup resistance (V <sub>CC</sub> =18V, I <sub>O</sub> =100mA)	—	1.3	—	Ω
R <sub>OL</sub>	Output pulldown resistance (V <sub>CC</sub> =18V, I <sub>O</sub> =100mA)	—	0.8	—	Ω
I <sub>PK</sub>	Peak output source current	—	2	—	A
I <sub>REV</sub>	Reverse current that latch protection can withstand (Working cycle ≤ 2%, V <sub>CC</sub> =18V, t <sub>s</sub> ≤ 300μs)	—	>0.5	—	A
t <sub>R</sub>	Rise time (V <sub>CC</sub> =18V, C <sub>LOAD</sub> =1800pF)	—	—	30	ns
t <sub>F</sub>	Fall time (V <sub>CC</sub> =18V, C <sub>LOAD</sub> =1800pF)	—	—	30	ns
t <sub>ON</sub>	Turn-on propagation delay (V <sub>CC</sub> =18V, C <sub>LOAD</sub> =1800pF)	—	30	50	ns
t <sub>OFF</sub>	Turn-off propagation delay (V <sub>CC</sub> =18V, C <sub>LOAD</sub> =1800pF)	—	30	50	ns
I <sub>Q1</sub>	VCC quiescent supply current (V <sub>INA</sub> =V <sub>INB</sub> =HIGH)	—	—	1	mA
I <sub>Q0</sub>	VCC quiescent supply current (V <sub>INA</sub> =V <sub>INB</sub> =LOW)	—	—	1	mA

Detailed description

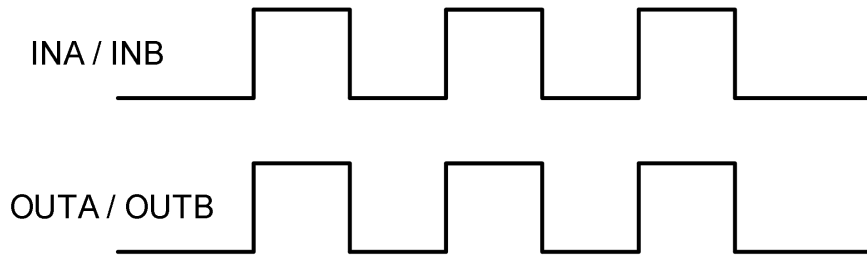

Figure 9-1 Input-Output Functionality Diagram

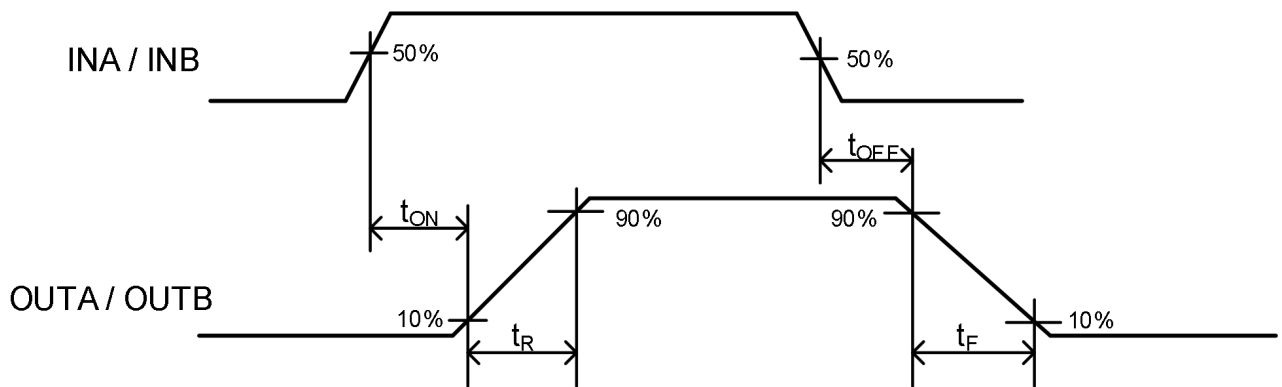

Figure 9-2 Switching Time Waveforms

Functional Block Diagram

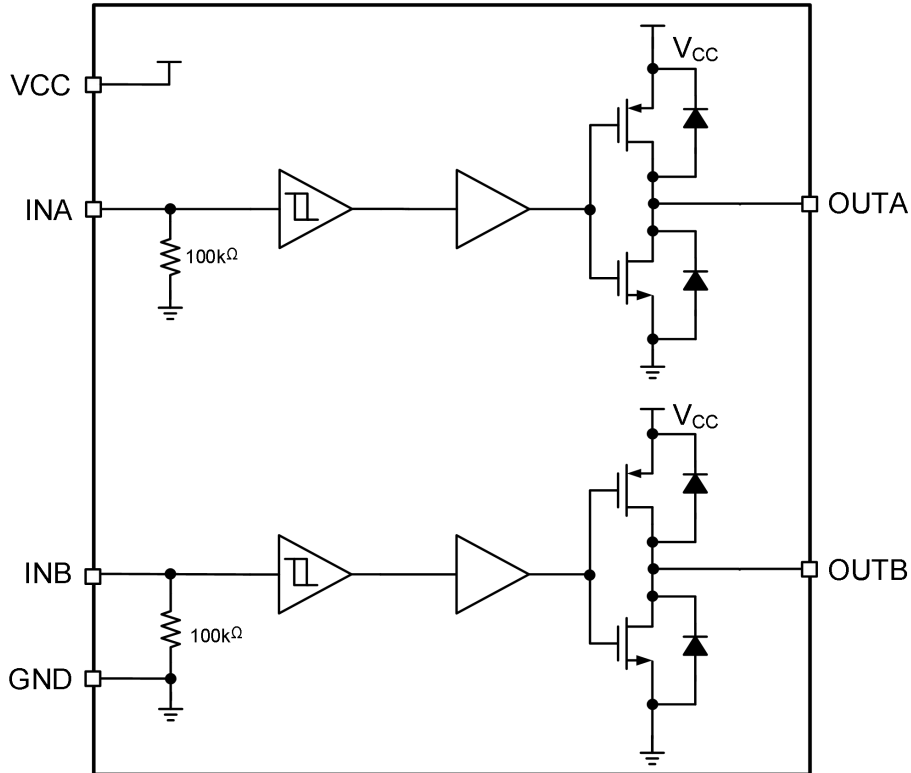

Figure 10-1 Function Block Diagram of IR4427STR

Typical Application

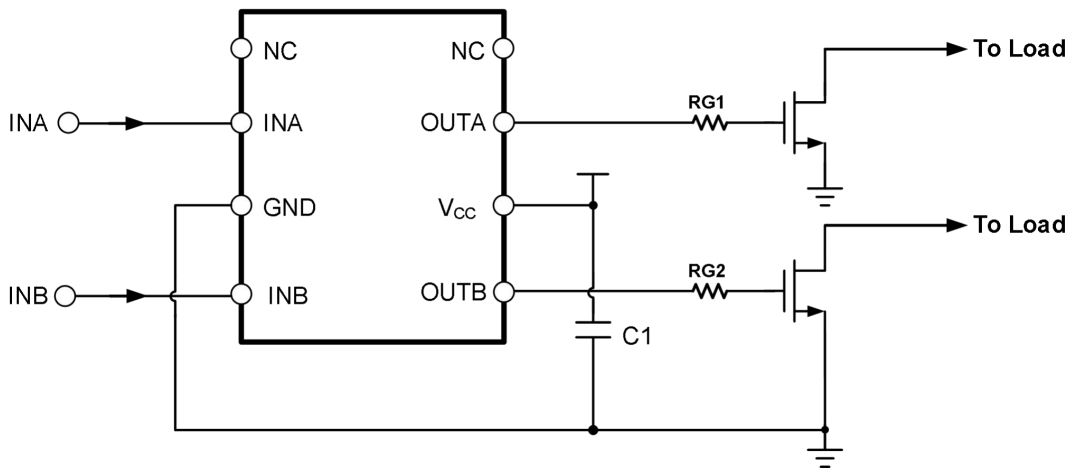
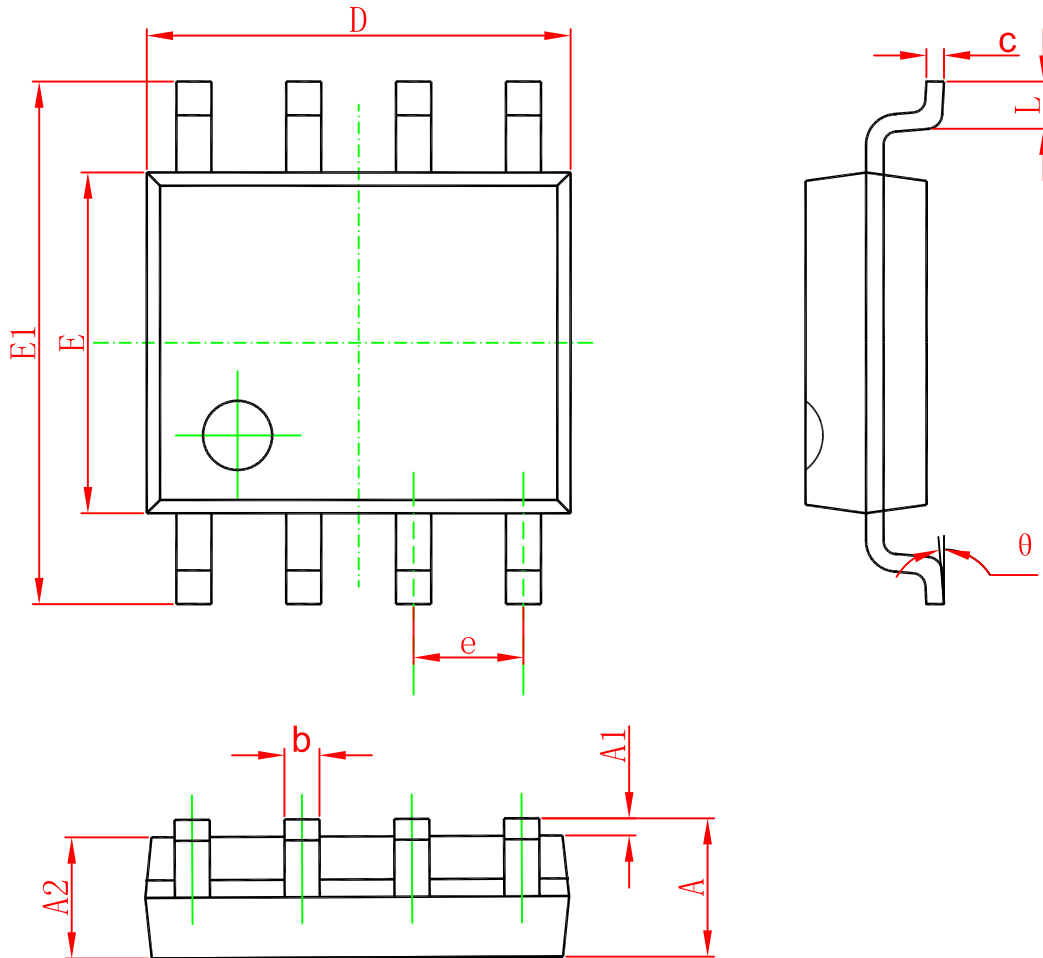

Figure 10-2 Typical Application Diagram of IR4427STR

**PACKAGING INFORMATION**  
**SOP-8**



Symbol	Dimensions In Millimeters		Dimensions In Inches	
	Min	Max	Min	Max
A	1.350	1.750	0.053	0.069
A1	0.100	0.250	0.004	0.010
A2	1.350	1.550	0.053	0.061
b	0.330	0.510	0.013	0.020
c	0.170	0.250	0.006	0.010
D	4.700	5.100	0.185	0.200
E	3.800	4.000	0.150	0.157
E1	5.800	6.200	0.228	0.244
e	1.270(BSC)		0.050(BSC)	
L	0.400	1.270	0.016	0.050
θ	0°	8°	0°	8°

**Marking**

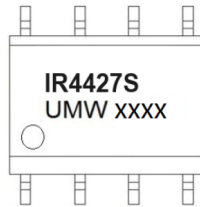

**Ordering information**

Order code	Package	Baseqty	Deliverymode
UMW IR4427STR	SOP-8	2500	Tape and reel