



Product Features

- Excellent Insertion Loss and Isolation performance
- High power handling P0.1dB 36dBm
- High Linearity /GPIO Control Interface
- Broadband frequency range: 0.1 to 3 GHz
- Small package: QFN-14 2.0mm x 2.0mm x 0.55mm
- No DC blocking capacitors required
- 1kV HBM ESD Protection on all pins

Product Applications

- 3G/4G multimode cellular tablets and Multi-Mode GSM, EDGE, WCDMA, LTE
- Diversity antenna switching and transmitting

Product Description

The LX3418H is a Silicon On Insulator (SOI) Single Pole, Eight Throw (SP8T) antenna switch which require very low insertion loss, high isolation and high linearity performance. The high linearity performance and low insertion loss for UMTS, CDMA2000, and LTE applications. The LX3418H is manufactured in a compact 2.0mm x 2.0mm x 0.55mm, 14-pin surface mount Quad Flat No-Lead (QFN) package.

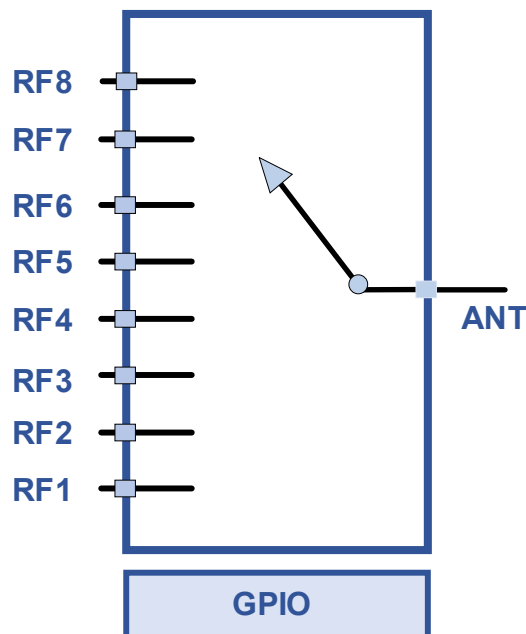

Figure 1 Functional Block Diagram

Absolute Maximum Conditions

Parameters	Symbol	Minimum	Maximum	Units
Supply voltage	V _{DD}	2.5	4.8	V
Control voltage	V _{CC}		3.1	V
RF input power	P _{in}		36	dBm
Storage temperature	T _{STG}	-55	+150	°C
Operating temperature	T _{OP}	-40	+90	°C
Human Body Model, Class 1C	ESD	1000		V

1: Test condition 50% duty cycle, VSWR=1:1, +25 ° C

Note: Exposure to maximum rating conditions for extended periods may reduce device reliability. There is no damage to device with only one parameter set at the limit and all other parameters set at or below their nominal value. Exceeding any of the limits listed here may result in permanent damage to the device.

General Electrical Specifications

Parameters	Symbol	Test Condition	Min.	Typ.	Max.	Units
Supply voltage	V _{DD}		2.5	2.85	4.2	V
Supply current, active mode	I _{DD}		30		50	μA
Control signal:						
High	V _{CTL}		1.35	1.8	2.70	V
Low					0.3	
Control current:	I _{CTL}				2.0	μA
Turn-on time (PIN = +27 dBm)	T _{ON}	Measured from 50% of final VDD supply voltage to 90% of RF power		1	2	μs
Switching time (PIN = +27 dBm)	T _{SW}	Measured from 50% of final VDD supply voltage to 90% of RF power		1	2	μs

(V_{DD} = 2.85 V, V_{CT} = 1.8 V, T_{OP} = +25 °C, Characteristic Impedance [Z₀] = 50 Ω, Unless Otherwise Noted)

RF Specifications

Parameters	Symbol	Test Condition	Min.	Typ.	Max.	Units
Operating frequency	f		0.1		3	GHz
Insertion loss	IL	Up to 1.0 GHz		0.40	0.50	dB
		Up to 2.0 GHz		0.50	0.60	
		Up to 2.7 GHz		0.60	0.70	
Isolation (ANT port to any receive port)	I _{so}	Up to 1.0 GHz	35	40		dB
		Up to 2.0 GHz	25	30		
		Up to 2.7 GHz	20	25		
2nd Order harmonics	2fo	Pin = +26 dBm,900MHz	-72	-75		dBm
3rd Order harmonics	3fo	Pin = +26 dBm,900MHz	-60	-68		dBm
0.1 dB Compression Point 50% duty cycle, VSWR=1:1	P0.1dB	900M, 50Ω		36		dBm

Truth Table

V1	V2	V3	ANT-RFX
0	0	0	ANT-RF1 on
0	0	1	ANT-RF2 on
0	1	0	ANT-RF3 on
0	1	1	ANT-RF4 on
1	0	0	ANT-RF5 on
1	0	1	ANT-RF6 on
1	1	0	ANT-RF7 on
1	1	1	ANT-RF8 on

LingChip Confidential

Pin-out Information

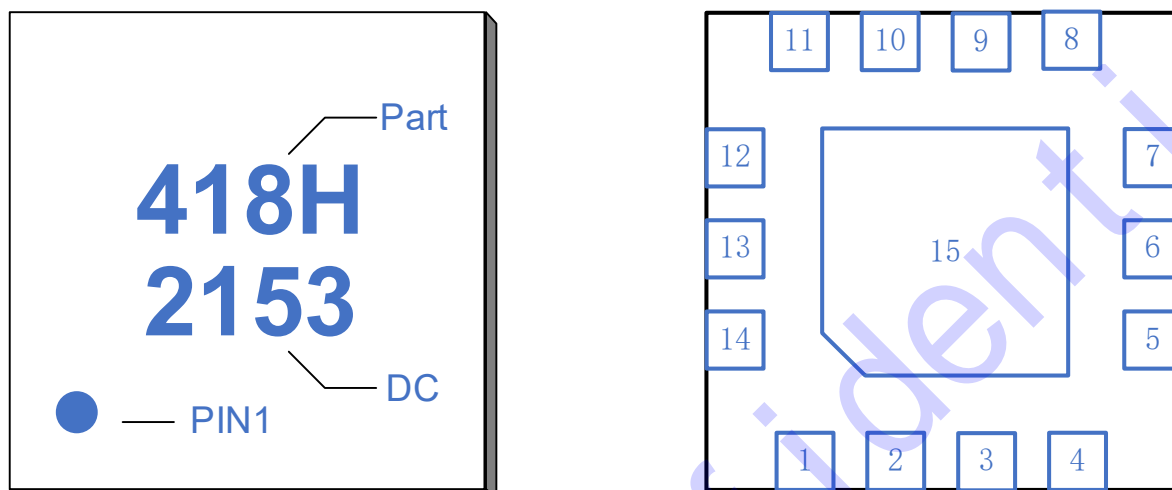

Figure 2 Pin-out Information

Table 1. Pin Description

Pin #	Name	Description	Pin #	Name	Description
1	RF5	RF Port 5	9	RF2	RF Port 2
2	RF3	RF Port 3	10	RF4	RF Port 4
3	RF1	RF Port 1	11	RF6	RF Port 6
4	VDD	Supply voltage	12	RF8	RF Port 8
5	V3	Control voltage	13	ANT	Antenna in
6	V2	Control voltage	14	RF7	RF Port 7
7	V1	Control voltage	15	GND	Ground
8	NC	Not Connect			

Application circuit

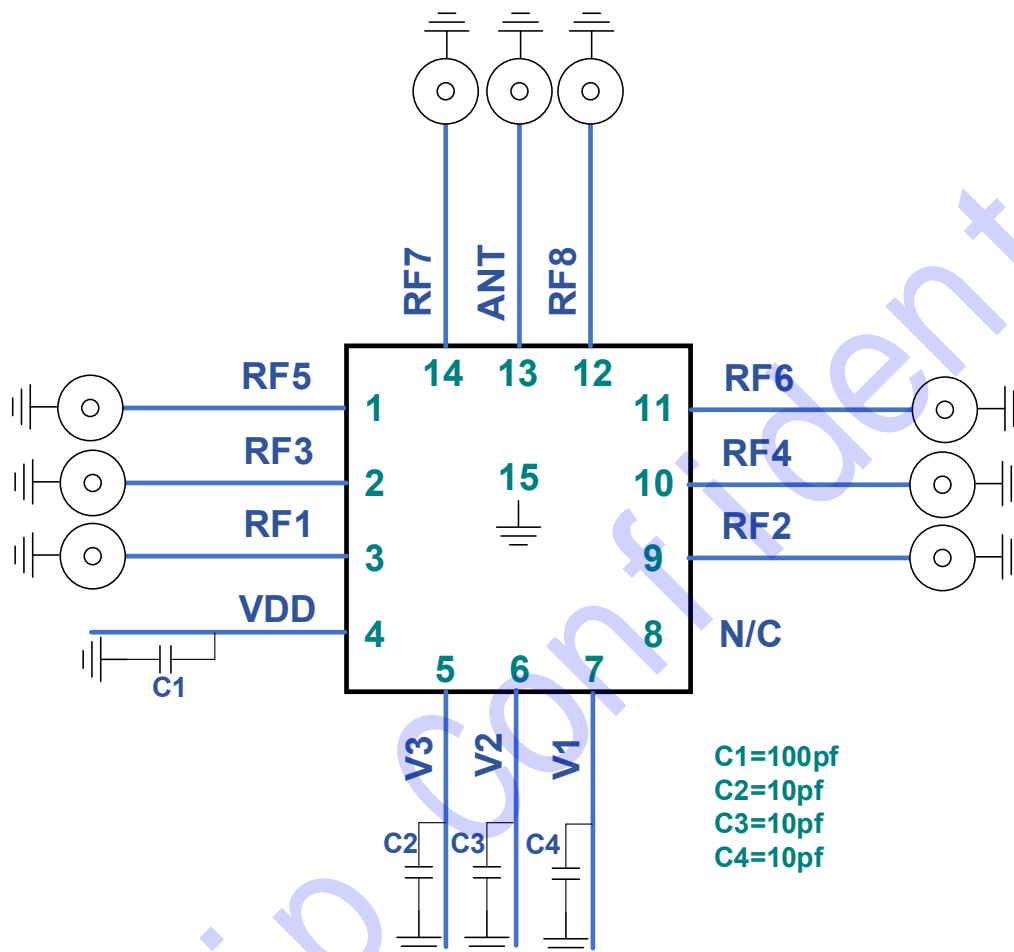

Figure 3 Application circuit

Evaluation Board

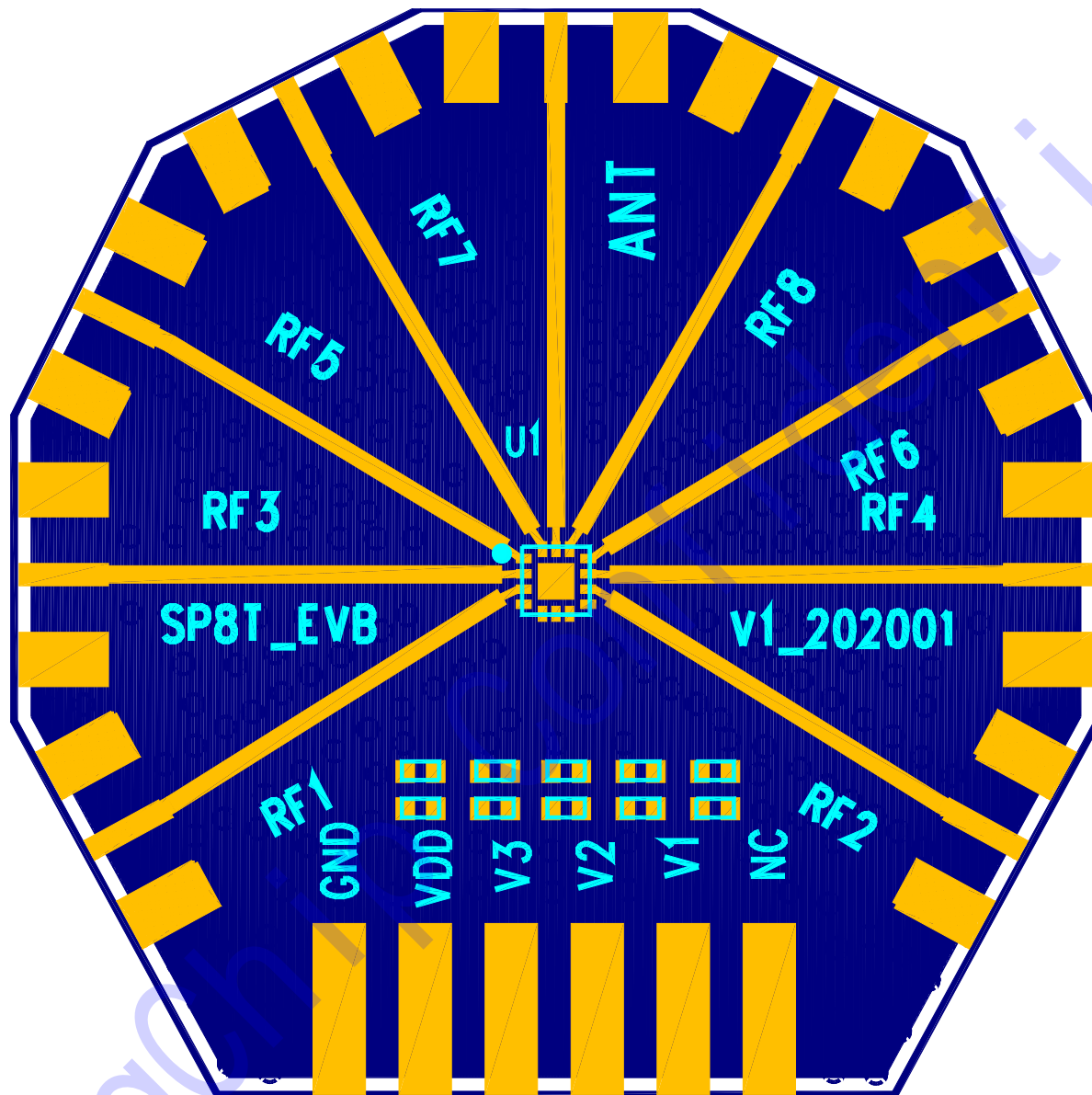
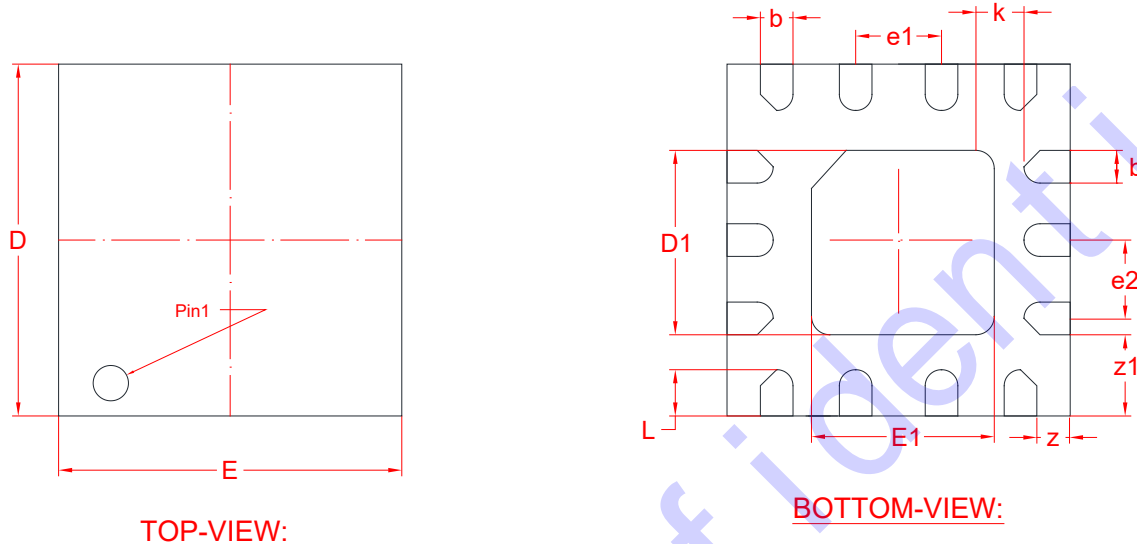

Figure 4 Evaluation Board Assembly Diagram

Package Outline Dimension



SYMBOL	MILLIMETER		
	MIN	NOM	MAX
A	0.50	0.55	0.60
A1	0.00	0.02	0.05
A2	0.127REF		
b	0.15	0.20	0.25
D	1.95	2.00	2.05
E	1.95	2.00	2.05
D1	0.95	1.00	1.05
E1	0.95	1.00	1.05
e1	0.40	0.45	0.50
e2	0.35	0.40	0.45
L	0.19	0.24	0.29
z	0.225REF		
z1	0.50REF		
K	0.26REF.		

Figure 5 Package Outline Dimension

Package Dimensions (5000pcs)

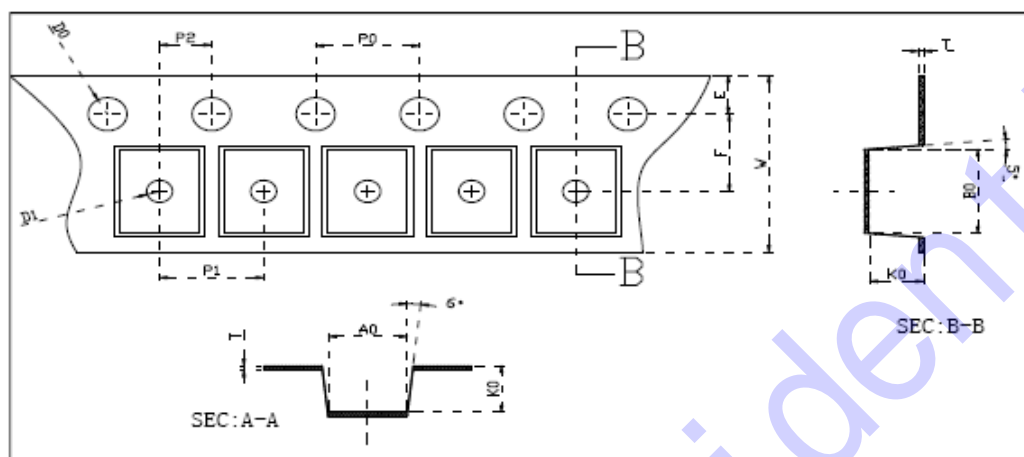

W	8.00±0.10	T	0.20±0.05	D1	1.00±0.10	单位	MM
E	1.75±0.10	F	3.50±0.10	D0	1.50±0.10	材质	PC+PS
P0	4.00±0.10	P1	4.00±0.10	P2	2.00±0.10		
A0	2.18±0.10	B0	2.20±0.10	K0	0.75±0.10		

Figure 6 Tape and Reel Dimensions

Declaration of No Harmful Substances

This part is compliant with 2005/20/EC packaging directive, 1907/2006/EC REACH directive and the 2011/65/EU RoHS directive (Restrictions on the Use of Certain Hazardous Substances in Electrical and Electronic Equipment), as amended by Directive 2015/863/EU.

This product also has the following attributes:

- Lead free
- Halogen Free (Chlorine, Bromine)
- SVHC Free

Reflow Chart

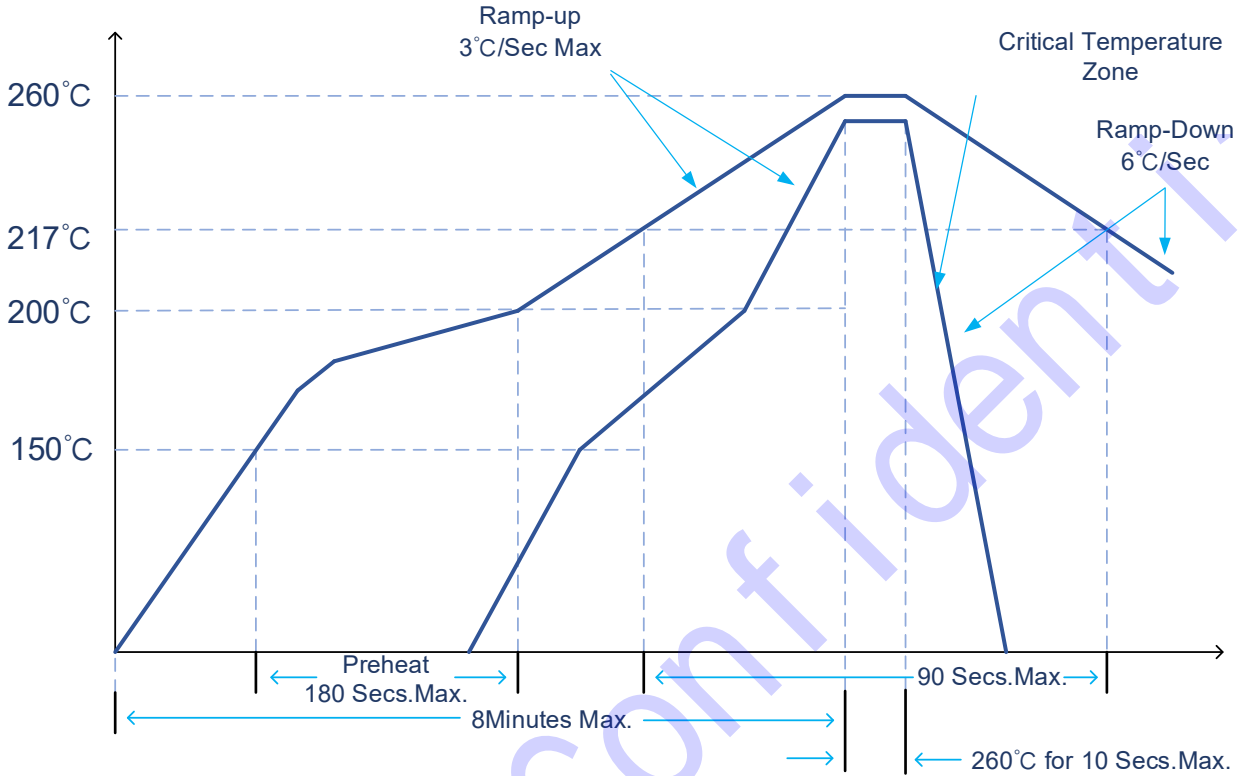

NOTE: Reflow Profile with 240°C peak also acceptable.