



User Guide

EVKT-MagAlpha-MagDiff



Table of Contents

Overview	3
Introduction	3
Kit Contents.....	4
Sensors Supported	4
Features and Benefits	4
Kit Specifications	5
Section 1. Hardware.....	6
PCB Overview	6
Schematic	7
Bill of Materials	8
Mechanical Drawing	8
Section 2. Software	9
Installation	9
Application Layout.....	11
Start-Up Page (Home Page)	12
Angle Page.....	12
Settings	13
Registers	15
Fields.....	16
Memory	17
Parameters.....	17
Measures	17
Common Errors.....	18
No EVKT Board Found.....	19
No Compatible Sensor Found	19
Updating the Firmware	20
Calibration and Correction Table Generation	20
Section 3. Ordering Information	23

Overview

Introduction

The EVKT-MagAlpha-MagDiff is a communication kit for the MagAlpha and MagDiff magnetic position sensor family (see Figure 1). The EVKT-MagAlpha-MagDiff offers a seamless connection and operation with all MagAlpha and MagDiff test boards (TBMA). The EVKT-MagAlpha-MagDiff kit contains a microcontroller (MCU) board, two flat ribbon cables, and a USB cable. It provides an easy and convenient way to read the sensor's angle and read/write to all configuration registers. Using this kit, it is also possible to compute and configure the angle correction table to further improve the sensor accuracy.

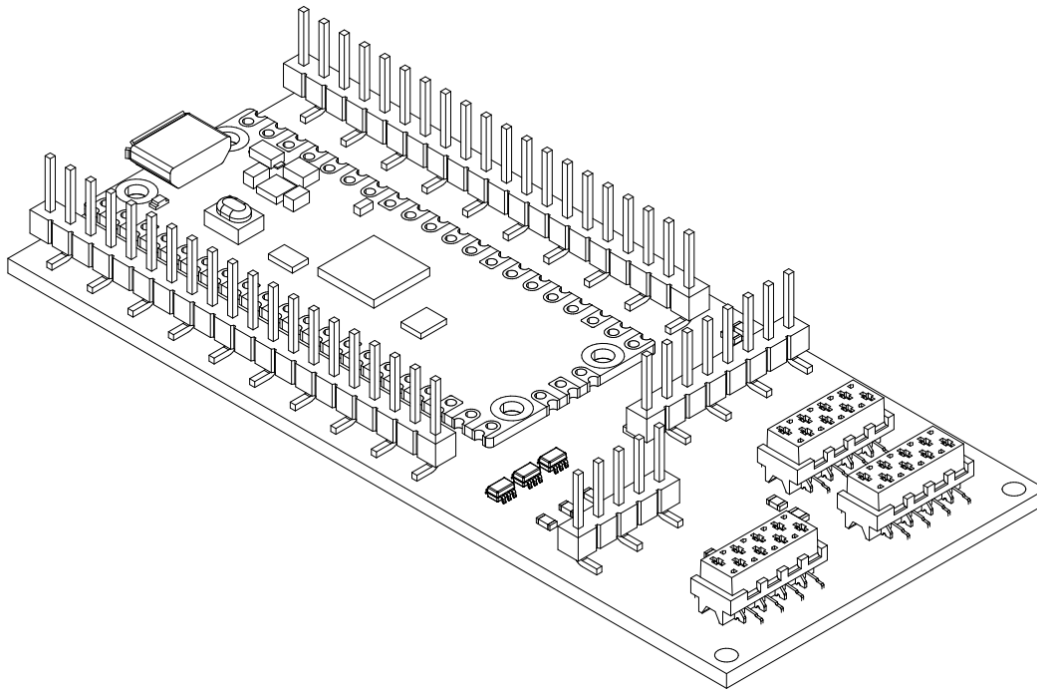

Figure 1: Overview of the EVKT Board

Figure 2 shows the EVKT-MagAlpha-MagDiff.

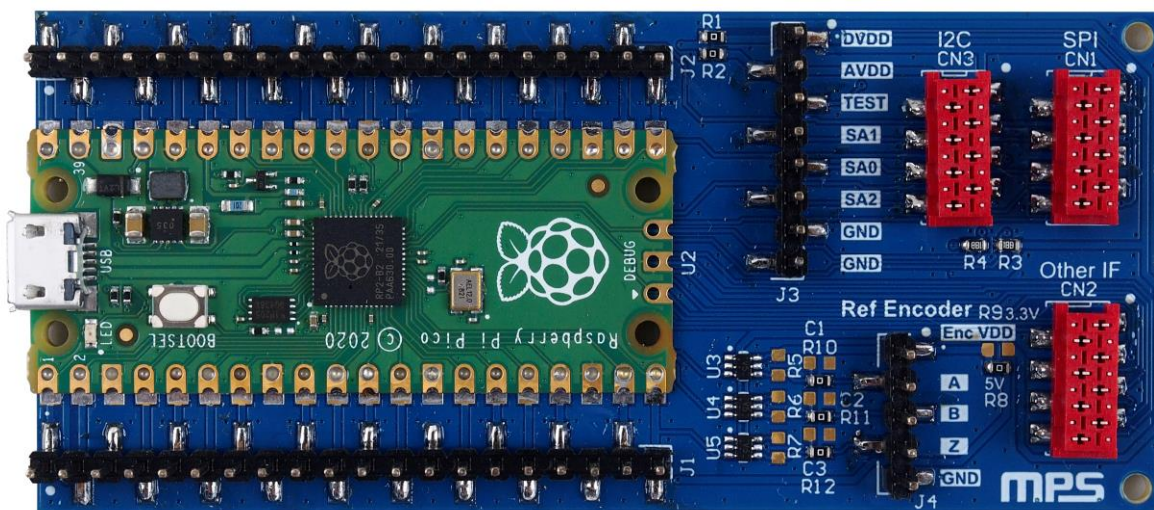

Figure 2: The EVKT-MagAlpha-MagDiff

Kit Contents

#	Part Number	Item	Quantity
1	EVKT-MA-RP-PICO-V2	MagAlpha and MagDiff evaluation board with MCU	1
2	Ribbon cable	8 conductors, flat ribbon cable	2
3	USB cable	USB cable, A Male to Micro B Male	1
4	Online resources	Include GUI, python library, and supplemental documents	-

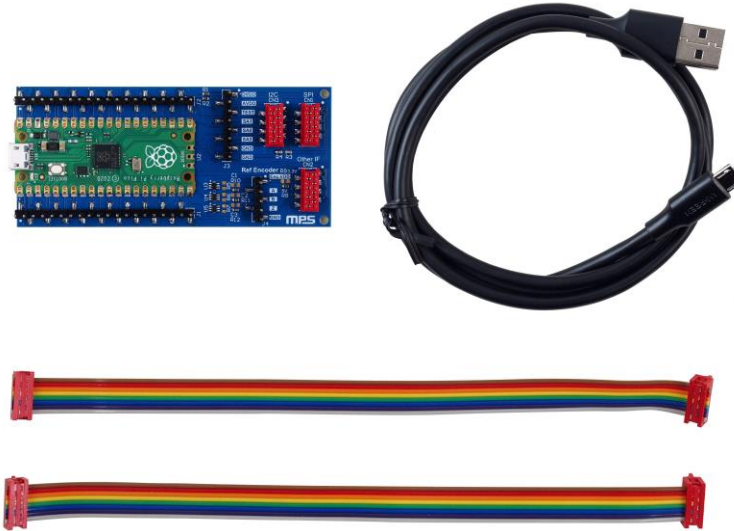

Figure 3: Kit Contents

Sensors Supported

Sensor Generation	Sensor Part Number
MA GEN 3	MA102, MA302, MA310, MA330, MA702, MA704, MA710, MA730, MA731, MA732, MA735, MA800, MA820, MA850, MAQ430, MAQ470, MAQ473, MAQ800, MAQ820, MAQ850, MAP790-xxxx, MAP791-xxxx, MP9961
MA GEN 4	MA780, MA781, MA782, MA734, MA736
MA GEN 6	MA600
MA GEN 7	MA900GQE-S (SPI), MA900GQE-C (I ² C), MAQ79010FSGQE-S (SPI), MAQ79010FSGQE-C (I ² C)

Features and Benefits

- USB Interface
- RP2040: 32-Bit Dual ARM Cortex-M0+ Microcontroller (MCU) from Raspberry Pi
- Connectors Compatible with MagAlpha and MagDiff Tests Boards (TBMA)
- Supports Serial Peripheral Interface (SPI) and I²C Interface
- Connection for a Reference Optical Encoder (Supports 5V or 3.3V) with Footprints to Add Pull-Up Resistors or RC Low-Pass Filters If Needed
- Correction Table Computation and Configuring when Used Alongside the GUI or Python Library

Figure 4 shows an overview of the kit. The components are listed below:

1. Sensor's SPI connector
2. Sensor's I²C connector
3. Sensor's ABZ/SSI/UVW/PWM connector
4. Reference encoder connector header
5. Reference encoder supply voltage selection (5V by default)
6. Reference encoder with optional pull-up resistors and low-pass filters
7. USB connector
8. Raspberry Pi Pico (SC0915 or SC0916)
9. RP2040 32-bit MCU

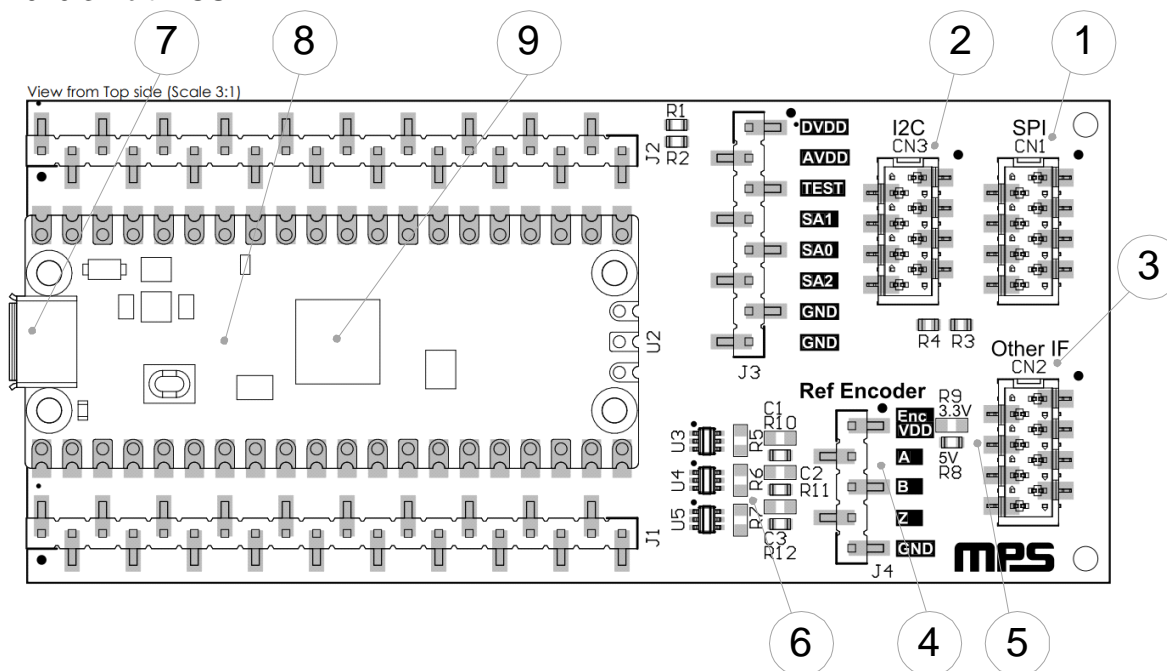

Figure 4: Kit Feature Overview

Kit Specifications

Features	Specifications
Supply for Test Board Board	3.3V
Operating Input Voltage	3.3V
Operating Systems Supported	Windows 10, or later
System Requirements	Minimum 351MB free
EVB Size (LxW)	9cmx4cm

Schematic

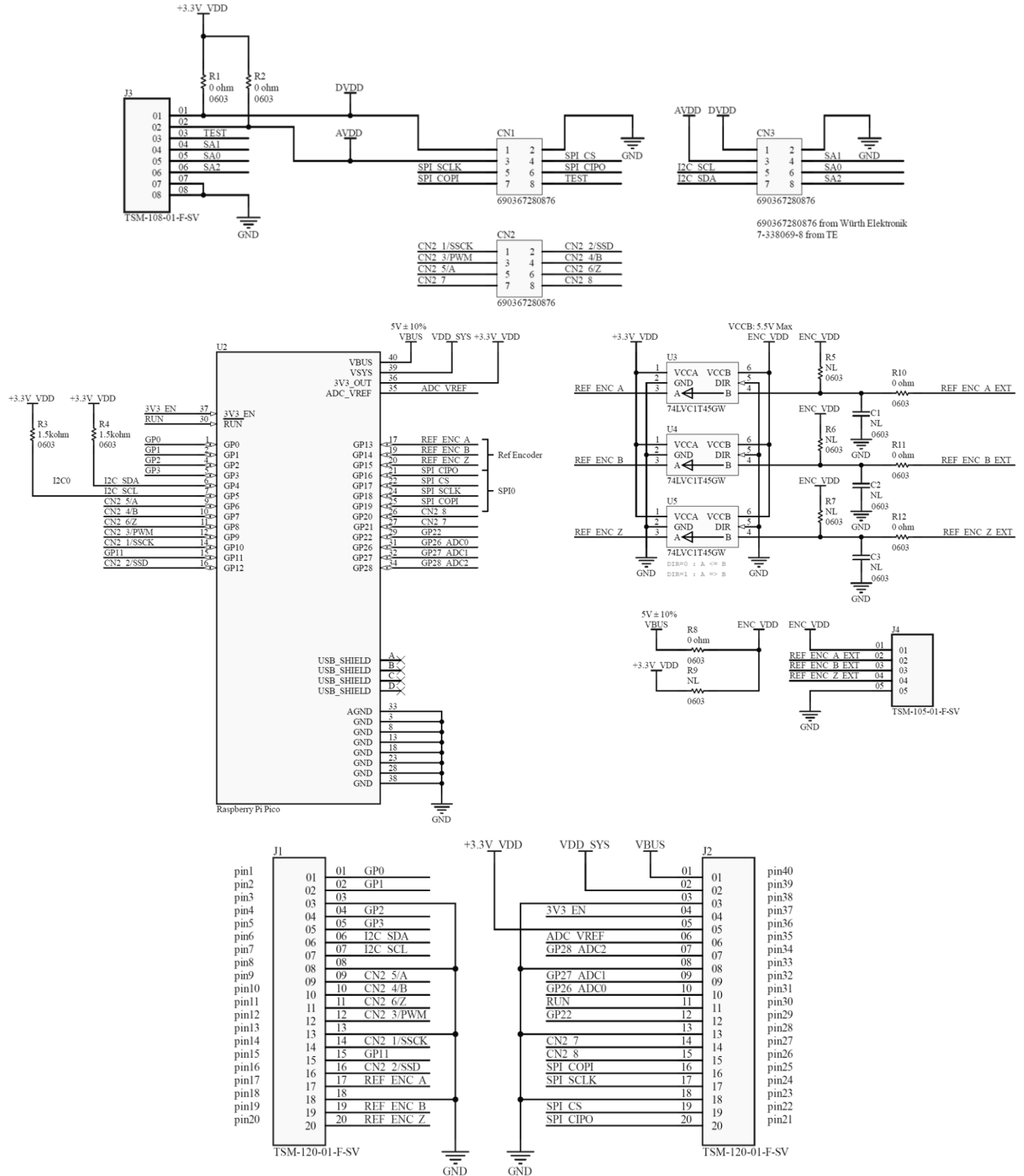

Figure 6: Schematic

Bill of Materials

Designator	Description	Manufacturer	Manufacturer PN
CN1, CN2, CN3	WR-MM female SMT connector	Würth	690367280876
J1, J2	2.54mm (100") pitch, 20-pin SMT header	Samtec	TSM-120-01-F-SV
J3	2.54mm (100") pitch, 8-pin SMT header	Samtec	TSM-108-01-F-SV
J4	2.54mm (100") pitch, 5-pin SMT header	Samtec	TSM-105-01-F-SV
R1, R2, R8, R10, R11, R12	0Ω resistor, 0603	Yageo	RC0603JR-070RL
R3, R4	1.5kΩ resistor, 0603	Vishay	CRCW06031K50FKTA
U2	Raspberry Pi Pico	Raspberry Pi	SC0915 or SC0916
U3, U4, U5	Dual supply translating transceiver	Nexperia	74LVC1T45GW

Mechanical Drawing

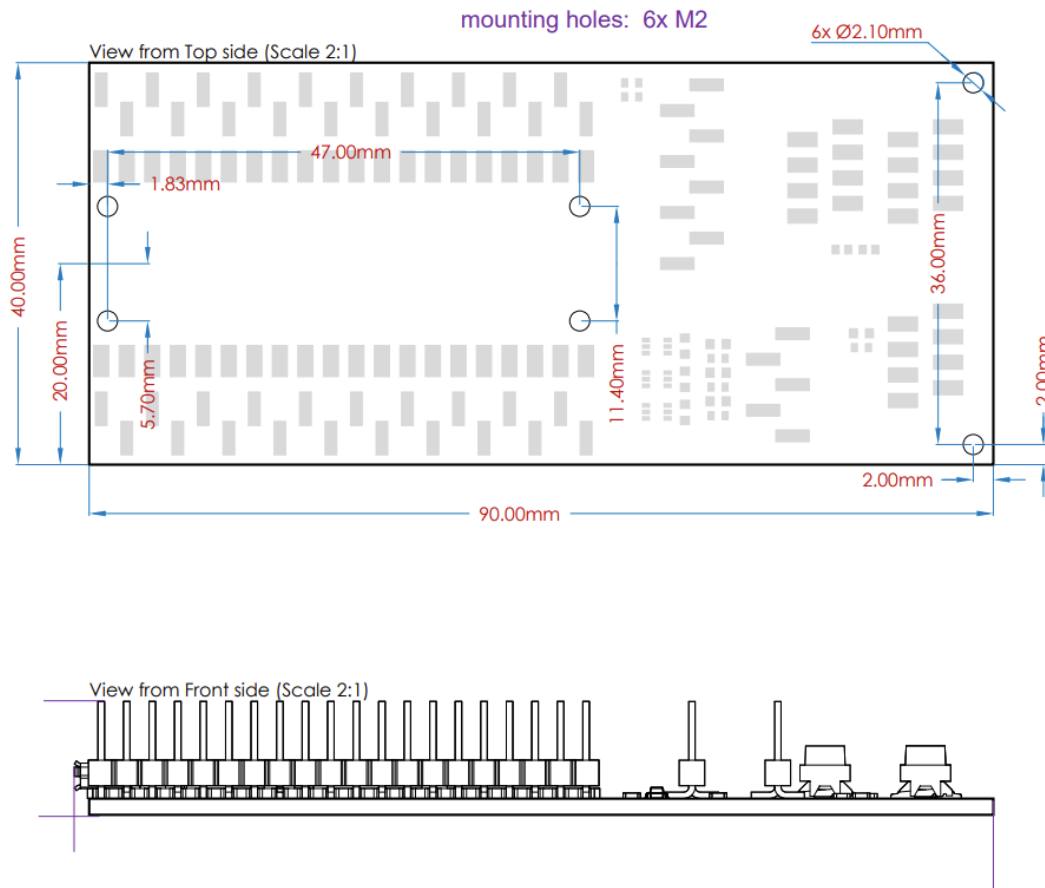

Figure 7: Mechanical Drawing

Section 2. Software

Installation

To install the software, follow the steps below.

1. Launch the app installer then click “Next” (see Figure 8).

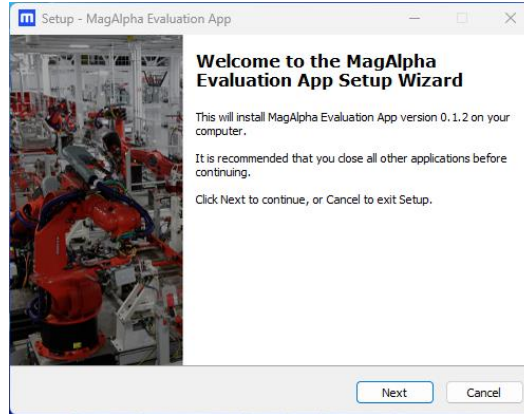

Figure 8: Start the Installation Wizard Application

2. Agree to the license agreement and click on “Next” (see Figure 9).

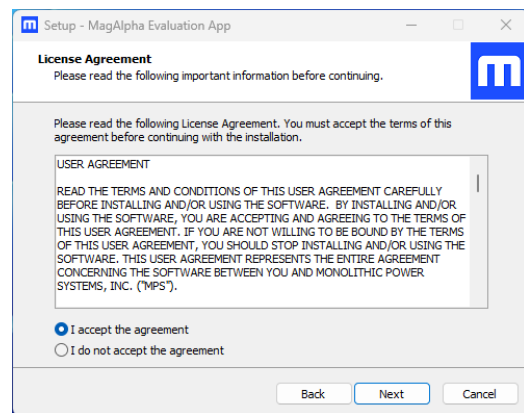

Figure 9: Installation Wizard (License Agreement)

3. Choose the destination folder and click “Next” (see Figure 10). Ensure that there is enough available storage for the installation.

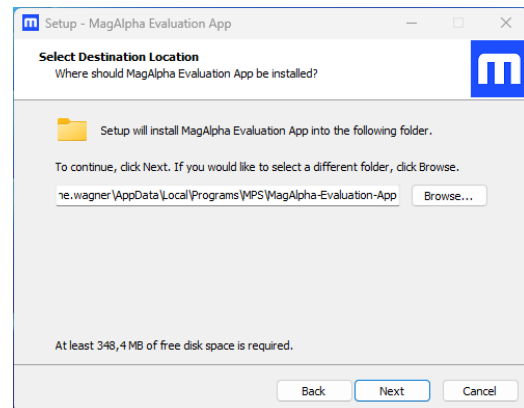

Figure 10: Installation Wizard (Destination Location)

4. Select whether to add a shortcut on your desktop (see Figure 11).

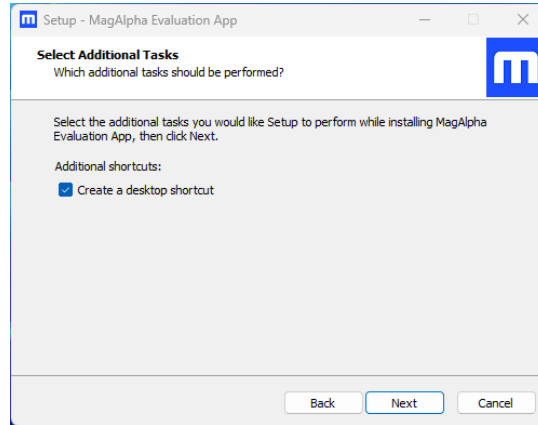

Figure 11: Installation Wizard (Additional Tasks)

5. Click “Install” (see Figure 12).

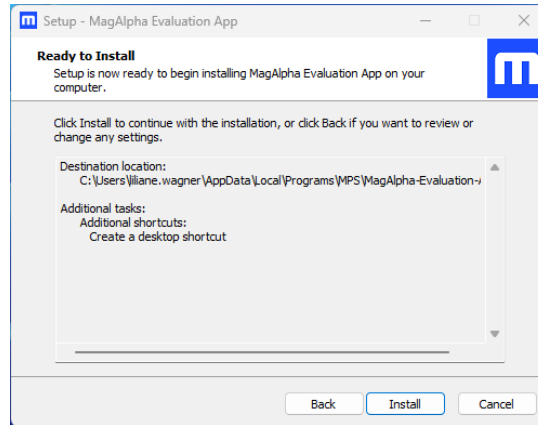

Figure 12: Installation Wizard (Installation Overview)

6. Wait for installation to be complete (see Figure 13).

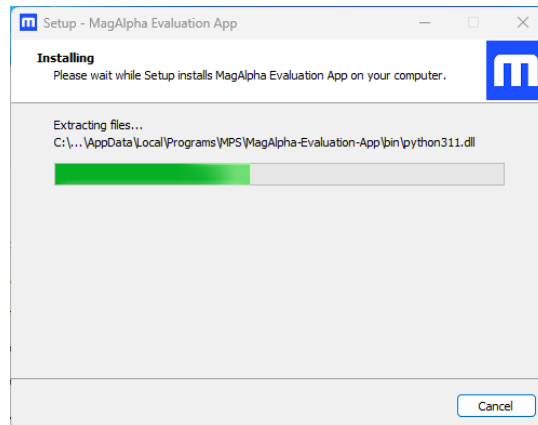

Figure 13: Installation Wizard (Installing)

7. Click “Finish” to end the installation and launch the application (see Figure 14).

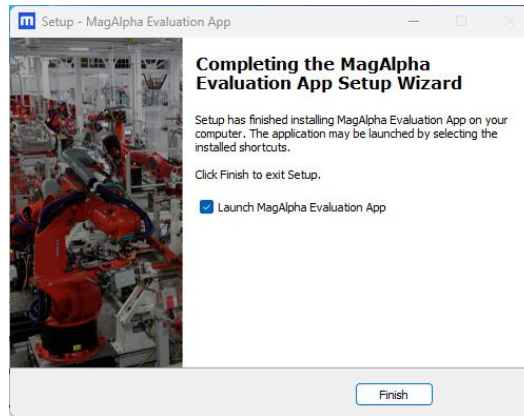

Figure 14: Installation Wizard (Complete)

Application Layout

The application window is divided into different sections (see Figure 15). The sections are explained below.

1. The center area shows charts and knob visualization.
2. The menu to switch between the different visualizations in the center area.
 - a. Home Page
 - b. Angle Page
3. The dock widgets can be moved, resized, pinned, and stacked on the right, left, top, and bottom side of the center area. These widgets can also be made floatable (separate dialog window).

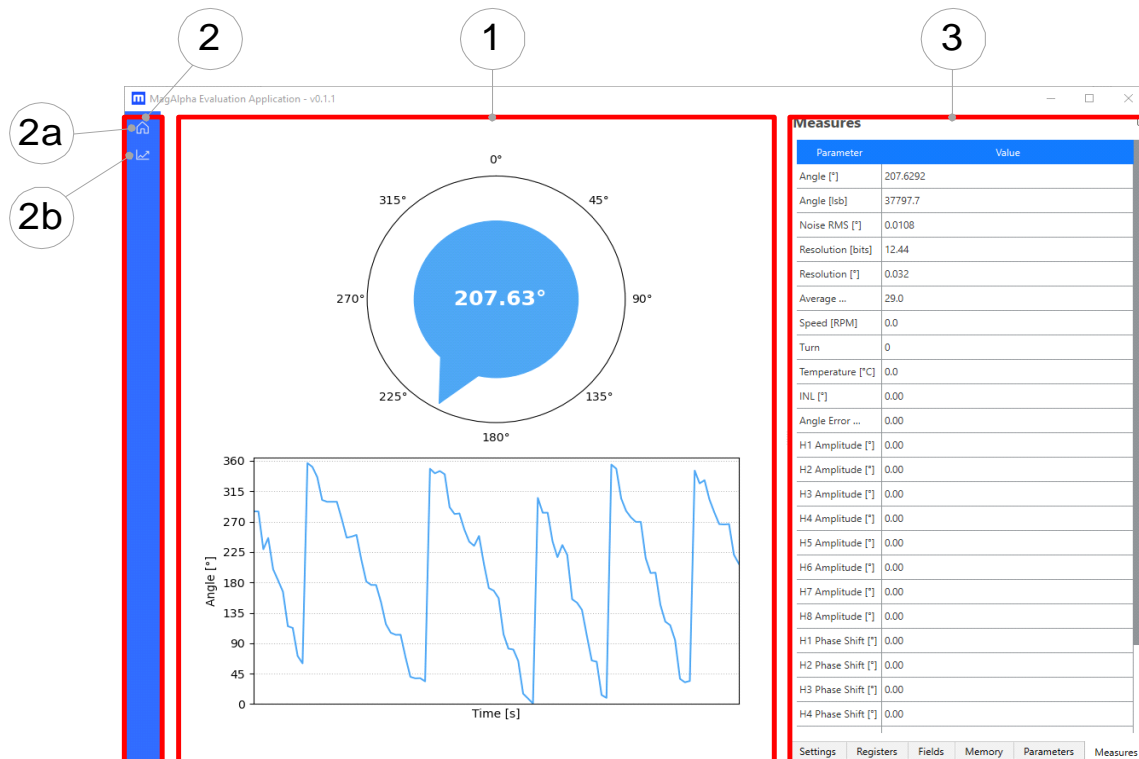

Figure 15: Application Layout

The application has the following dock widgets:

1. Measures
2. Settings
3. Registers
4. Fields
5. Memory
6. Parameters

Start-Up Page (Home Page)

At start-up, a screen appears (see Figure 16). The screen shows a knob and a rolling chart showing the current angle value in the center area of the window. This page is well-suited for human machine interface (HMI) applications with a slow rotation speed. It only shows the averaged angle value of the latest acquisition.

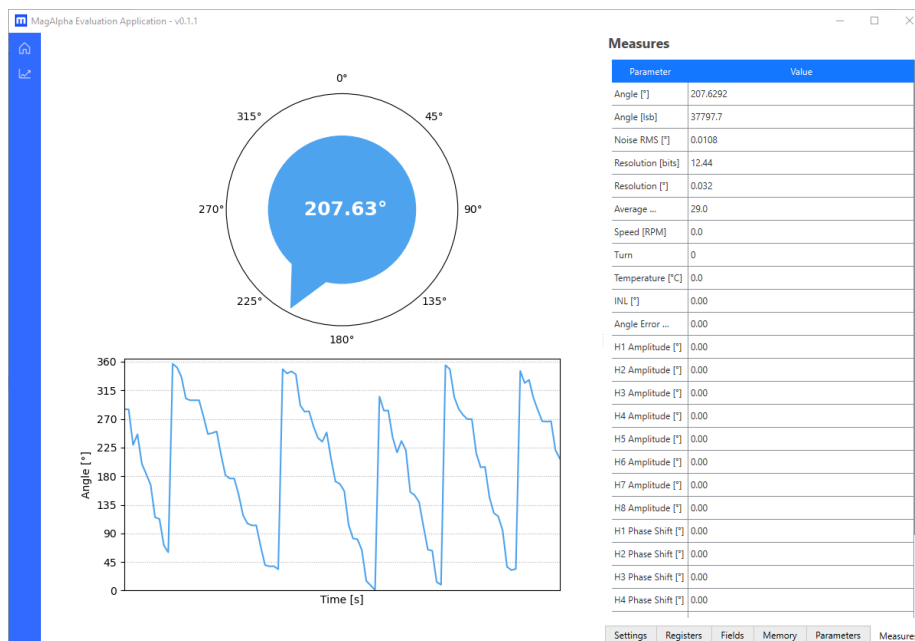

Figure 16: Home Page

Angle Page

Users can switch to the angle page by clicking on the “Angle” button on the menu in the top left corner of the window. This page is recommended for applications with a higher rotation speed or if the user would like to visualize each measured angle (see Figure 17 on page 13).

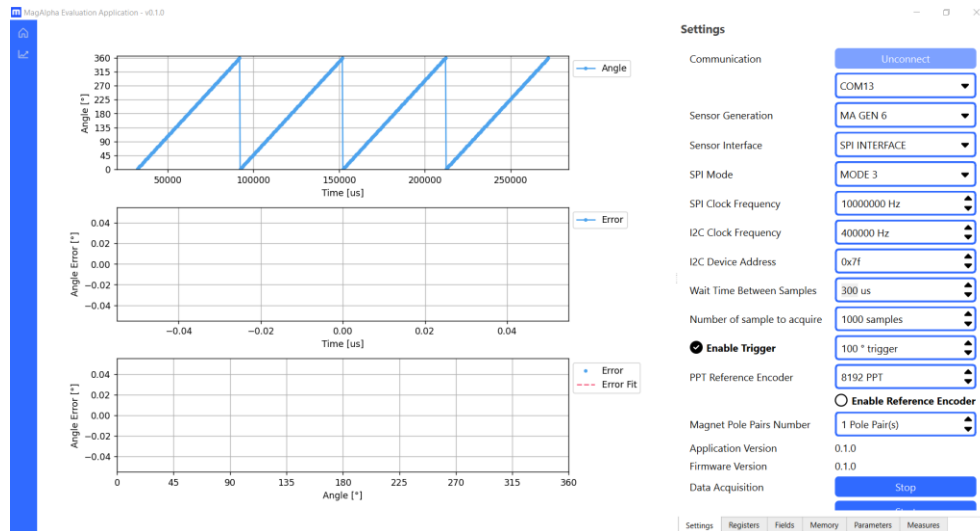

Figure 17: Angle Page

Settings

Figure 18 shows the settings. These settings are described in greater detail below.

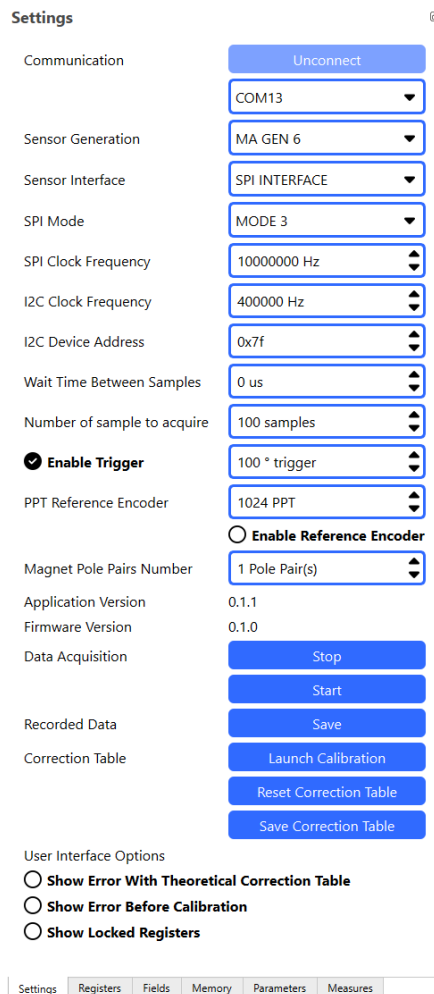

Figure 18: Settings

1. **Communication:** Defines the port used by the communication board and triggers a connection/disconnection to the computer. The correct COM port address is automatically detected by the application. If a board is already connected at the application's start-up, the connection is automatically triggered, and no action is required from the user to start reading the sensor. An error message is displayed if no compatible board is detected. See the No EVKT Board Found section on page x for more information.
2. **Sensor Generation:** Defines the sensor generation connected to the board through the CN1 or CN3 connector. Sensor generation is automatically detected by the application, and no user input is required. An error message is displayed if no compatible sensor is detected. See the No Compatible Sensor Found section on page x for more information.
3. **Sensor Interface:** Defines the serial communication interface to use with the connected sensor. The application and evaluation kit support both SPI and I²C interfaces (most sensors use SPI). The interface is automatically detected by the application at start-up. The test board's flat ribbon cable must be connected to the correct connector on the EVKT-MagAlpha-MagDiff. The test board using the SPI must be connected on CN1, while the board using the I²C interface must be connected on CN3. An error message is displayed if no compatible sensor or interface is detected. See the No Compatible Sensor Found section on page x for more information.
4. **SPI Mode:** Defines the clock polarity and clock phase to communicate with the sensor. Refer to the relevant sensor's datasheet for more information.
5. **SPI Clock Frequency:** Defines the SPI clock frequency used to communicate with the sensor. The input frequency might not be the actual frequency used by the MCU. The MCU firmware tries to use the closest frequency available by using the available system clocks and frequency dividers. Users are advised to measure the SPI SCLK clock frequency used by the system if a precise value is required.
6. **I²C Clock Frequency:** Defines the I²C clock frequency used to communicate with the sensor. The input frequency might not be the actual frequency used by the MCU. The MCU firmware tries to use the closest frequency available by using the available system clocks and frequency dividers. Users are advised to measure the I²C SCL clock frequency used by the system if a precise value is required.
7. **I²C Device Address:** Defines the I²C device address used by the MCU to communicate with the sensor. The I²C device address of each sensor can be defined by setting some sensor pins to a specific logic level at the sensor's start-up. Refer to the relevant sensor's datasheet for more information.
8. **Wait Time Between Samples:** Defines the duration of the additional waiting time inserted between each angle measurement. The evaluation kit board reads the sensor's angle output as fast as possible. The actual sensor's sampling rate is influenced by the selected serial interface and its clock frequency. This parameter allows users to reduce the angle's sampling rate. This is especially useful for measurements that require at least one full rotation to compute the results. The measurements include the angle error, INL, calibration, and harmonics extraction. The median sampling period can be read on the Measures dock widget (see Figure 15 on page 11).
9. **Number of samples to acquire:** Defines the number of angles to acquire from the sensor with each new measurement. This value also defines the number of data points that are used to compute the noise root mean square (RMS) and the angle's resolution. The maximum value of this parameter is 2048 samples. If this value is still too small to capture a full angle rotation, it is recommended to increase the wait time between samples.
10. **Enable Trigger:** Enables the zero-crossing condition to initiate a trigger on the angle output using the angle difference defined on the spinbox. When enabled, this feature only displays angular values between two zero-crossings. Zero-crossing is defined as the position at which the absolute difference



between two consecutive angle measurements is above or equal to the value defined in the angle trigger spinbox.

11. PPT Reference Encoder: Defines the number of pulses per turn (PPT) (per channel) used by the reference encoder. A PPT of 1024 means that the encoder has 2048 edges per channel and 4096 edges in total on the A and B signals. This parameter is only required when a reference encoder is connected and enabled.
12. Enable Reference Encoder: Enables the reference encoder input of the evaluation kit. Once this feature is enabled, the MCU reads the reference encoder angle before each sensor angle measurement. This allows the application to compute the angle error and perform the angle calibration.
13. Magnet Pole Pairs Number: Defines the number of pole pairs of the sensed magnet (also called the target magnet). Most set-ups use a single pole pair magnet. This means that a full mechanical rotation of the magnet will produce a single magnetic rotation (0° to 360°, measured by the sensor). A two pole pairs magnet produces two magnetic rotations for each single mechanical rotation. This parameter computes angular errors and performs calibration.
14. Data Acquisition Start, Stop: Allows users to stop and restart data acquisition. Data acquisition automatically starts at the application's start-up if a sensor is detected.
15. Recorded Data: Saves the acquired data into a file.
16. Correction Table:
 - a. Launch Calibration: Performs the sensor calibration to minimize angle errors. This feature requires a reference encoder to be connected and correctly configured. At least one full mechanical rotation of the magnet is required to compute the correction table. The calibration procedure starts by resetting any zero settings and correction table previously written into the sensor registers, then measures the sensor's angle output. The algorithm computes the correction table, writes it into the sensor registers, and stores these registers into the multiple-time programmable (MTP) memory. This feature is only available for the MA600.
 - b. Reset Correction Table: Resets the correction table that has been written into the sensor registers. This feature is only available on the MA600.
 - c. Save Correction Table: Saves the angle correction table into a file. This feature is available on all sensors.
17. Show Error With Theoretical Correction Table: Displays the preview of the angle error after calibration. This feature emulates the correction table. It does not write to any registers. This feature is available on all sensors.
18. Show Error Before Calibration: Displays the angle error measured before calibration. This information is only available after having performed a sensor calibration.
19. Show Locked Registers: Shows the locked registers and fields on the Registers and Fields dock widgets (see Figure 15 on page 11). By default, these registers are hidden.

Registers

Users can read and write to the register values in decimal, hexadecimal, or binary format. Once the register value editing is done, the user click "Enter" twice to finalize the write operation (once to finish the edition process and again to send the entered value to the sensor).

Click "Read Registers" to read all sensor registers (see Figure 19 on page 16).

Registers

Read Registers			
Register	Value [decimal]	Value [hex]	Value [binary]
Register 0	0	0X00	0000_0000
Register 1	0	0X00	0000_0000
Register 2	0	0X00	0000_0000
Register 3	0	0X00	0000_0000
Register 4	96	0X60	0110_0000
Register 5	255	0XFF	1111_1111
Register 6	248	0XF8	1111_1000
Register 7	0	0X00	0000_0000
Register 8	192	0XC0	1100_0000
Register 9	0	0X00	0000_0000
Register 10	0	0X00	0000_0000
Register 11	32	0X20	0010_0000
Register 12	16	0X10	0001_0000

Settings Registers Fields Memory Parameters Measures

Figure 19: Registers

Fields

Users can write field values by editing the value of the target field. Additional information about each field can be displayed by hovering the mouse cursor on top of the desired field.

Click “Read Fields” to read all the sensor fields (see Figure 20).

Read Fields								
Add Name	7	6	5	4	3	2	1	0
0 ZERO0	0 ZERO[7:0]							
1 ZERO1	0 ZERO[15:8]							
2 BCT0	0 BCT							
3 BCT1								<input type="radio"/> ETX
4 ABZ0	3 PPT[2:0]	0 ILIP					<input type="radio"/> PPT[11]	
5 ABZ1	255 PPT[10:3]							
7 UVW	0 NPP[2:0]							
8 PWM	<input checked="" type="checkbox"/> PWMM <input checked="" type="checkbox"/> PWMF							
9 DIR	<input type="radio"/> RD							
10 IO0	<input type="radio"/> DAISY							<input type="radio"/> RWM
11 IO1	<input type="radio"/> OD615 <input type="radio"/> OD243 <input checked="" type="checkbox"/> SPULLIN <input type="radio"/> TRISTATE							

Settings Registers Fields Memory Parameters Measures

Figure 20: Fields

Memory

The Memory panel allows users to control the sensor's non-volatile memory (NVM) storing and restoration operation (see Figure 21). The available features depend on the generation of the sensor (generation 1, generation 2, and so on) connected to the evaluation kit.

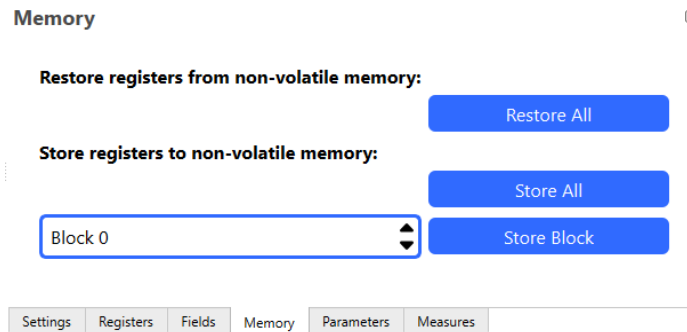

Figure 21: Memory

Parameters

This panel provides simple and convenient access to some of the sensor's parameters and serves as an alternative to the Registers and Fields panels. It allows users to modify the current angle value as the new zero, or to set the zero and BCT settings using sliders (refer to the related sensor datasheet for more information).

The available features depend upon the generation of the sensor connected to the evaluation kit.

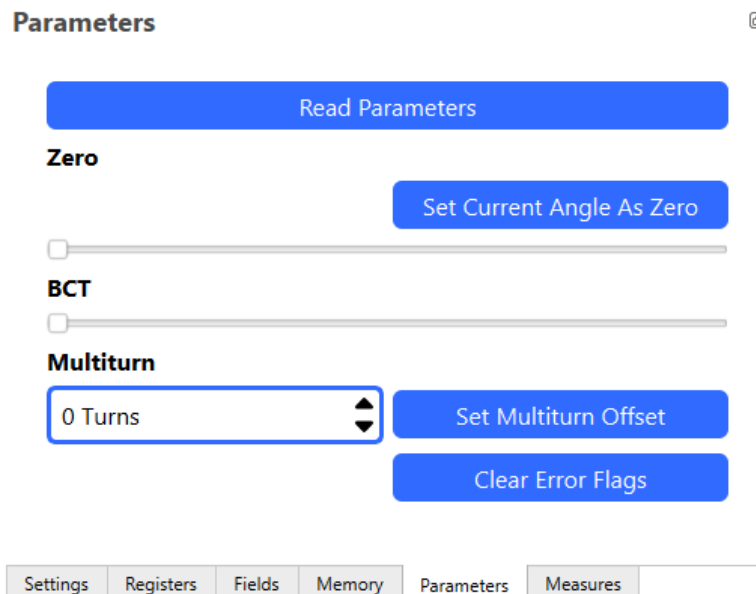

Figure 22: Parameters

Measures

This panel shows all measurements performed by the application. In addition to the angle value (in degrees) and the LSB, it also shows the noise RMS and resolution. If a reference encoder is connected to the evaluation kit board, this section can also display the angle error, its harmonics decomposition, offset, and INL (see Figure 23 on page 18).

Measures ⊞

Parameter	Value
Angle [°]	286.4540
Angle [lsb]	52147.4
Noise RMS [°]	0.0112
Resolution [bits]	12.38
Resolution [°]	0.034
Average ...	29.0
Speed [RPM]	0.0
Turn	0
Temperature [°C]	0.0
INL [°]	0.00
Angle Error ...	0.00
H1 Amplitude [°]	0.00
H2 Amplitude [°]	0.00
H3 Amplitude [°]	0.00
H4 Amplitude [°]	0.00
H5 Amplitude [°]	0.00
H6 Amplitude [°]	0.00
H7 Amplitude [°]	0.00
H8 Amplitude [°]	0.00
H1 Phase Shift [°]	0.00
H2 Phase Shift [°]	0.00
H3 Phase Shift [°]	0.00
H4 Phase Shift [°]	0.00
H5 Phase Shift [°]	0.00
H6 Phase Shift [°]	0.00
H7 Phase Shift [°]	0.00
H8 Phase Shift [°]	0.00

Settings Registers Fields Memory Parameters Measures

Figure 23: Measures

Common Errors

This section describes the most common issues that could be encountered by the users.

No EVKT Board Found

This error message is displayed if the application is not able to detect a compatible evaluation kit board (see Figure 24).

Usually, this error is caused by an incorrect USB connection or a defective USB port on the host computer. In some cases, this issue can be solved by using a shorter USB cable.

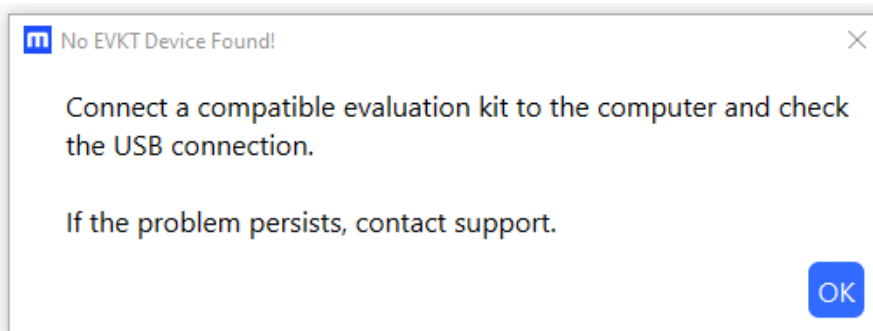

Figure 24: No EVKT Board Found Error

No Compatible Sensor Found

This error message is displayed if no compatible sensor is found or if no sensor is connected to the evaluation kit board.

This error is usually caused by an incorrect connection related to the flat ribbon cable connecting the evaluation kit to the sensor's test board. Check the cable connection to the CN1 (for the SPI sensor) or CN3 (for I²C sensor) connectors.

This error might also be caused by a newly released sensor that is not yet supported by the current evaluation kit firmware. It is recommended to download the latest version of the application and update the evaluation kit firmware with the latest available version within the application.

See the Updating the Firmware section on page 20 for more instructions.

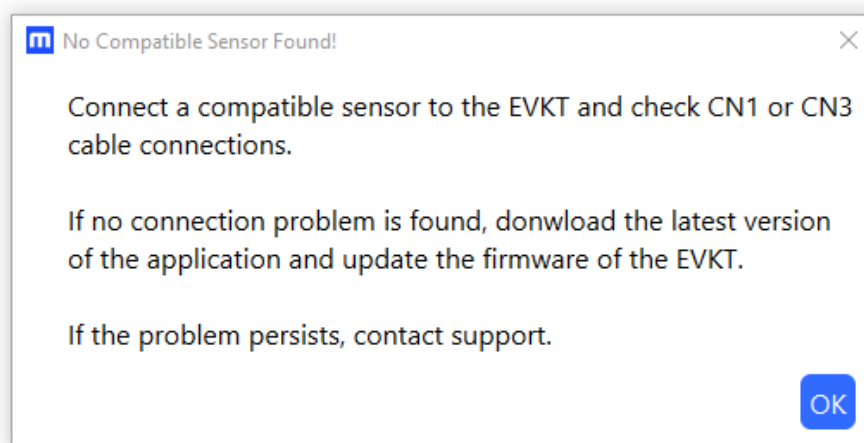

Figure 25: No Compatible Sensor Found Error

Updating the Firmware

To update the firmware on the Raspberry Pi Pico board, follow the step below:

1. Disconnect the USB cable from the Raspberry Pi Pico.
2. Press the BOOTSEL button and hold it while reconnecting the USB cable between the Raspberry Pi Pico and the host computer (see Figure 26).
3. The Raspberry Pi Pico should be recognized as a USB mass storage device by the host computer. The BOOTSEL button can be released.
4. Drag and drop the firmware to upload the firmware to the new USB mass storage device.
5. The firmware is automatically uploaded, and the device should restart in normal operating mode once the update is complete.

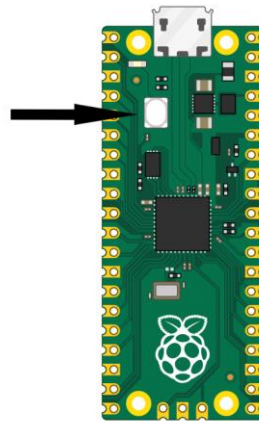

Figure 26: BOOTSEL Button on the Raspberry Pi Pico

The firmware can be found in the application installation folder. An example of the installation path is below.

```
C:\Users\username\AppData\Local\Programs\MPS\MagAlpha-Evaluation-App\bin\resources\firmware
```

Calibration and Correction Table Generation

To perform the sensor calibration and/or generate a correction table, the following items are required:

- A motor rotating the set-up to calibrate at a constant speed. At least one full rotation should be measured.
- A high-accuracy reference encoder (typically an optical encoder) connected to the evaluation kit. It is recommended to use an encoder with 1024 PPT or higher.

To access the calibration feature, follow the steps below:

1. Click on “Angle Page” on the menu.
2. Display the “Settings” panel.
3. Set the number of PPT used by the reference encoder in the settings panel.
4. Set the number of pole pairs of the magnet measured by the sensor.
 - a. If a multiple pole pairs magnet is used, the calibration algorithm computes the average error for a full mechanical turn. This may limit the accuracy of the calibrated system, especially if the pole pairs have a different angle error (asymmetrical).



5. Set the number of samples to acquire to have enough data points to be able to compute the angle error accurately. The maximum number of samples supported is 2048. It is recommended to start by using 2048 samples. It is possible to reduce the number of samples used to optimize the calibration time.
6. Enable the Trigger checkbox. The default trigger value of 100° is sufficient for most set-ups.
7. Set the wait time between samples to observe at least one full mechanical rotation. This value depends on the magnet's rotation speed and of the SPI or I²C clock speed. For example, a slower clock speed reduces the sampling rate.
8. Enable "Enable Reference Encoder".
9. Set the zero settings of the sensor to 0.
10. Click "Save Correction Table" to save the correction table into an Excel or CSV file.
 - a. On the MA600, which has an embedded correction table, it is also possible to click "Launch Calibration". This will reset the zero settings of the sensor to 0 and reset any previously written correction table. Then the calibration algorithm will acquire a new set of angle data, compute the error using the reference encoder, and generate the correction table. This correction table is written on the registers and finally stored in the sensor's MTP.

Other features are listed below:

- It is possible to compare the charts before and after calibration by enabling the "Show Error Before Calibration" checkbox.
- The correction table for the MA600 can be reset manually by clicking "Reset Correction Table". This does not reset the value stored in the MA600's MTP, and it only resets the register values.

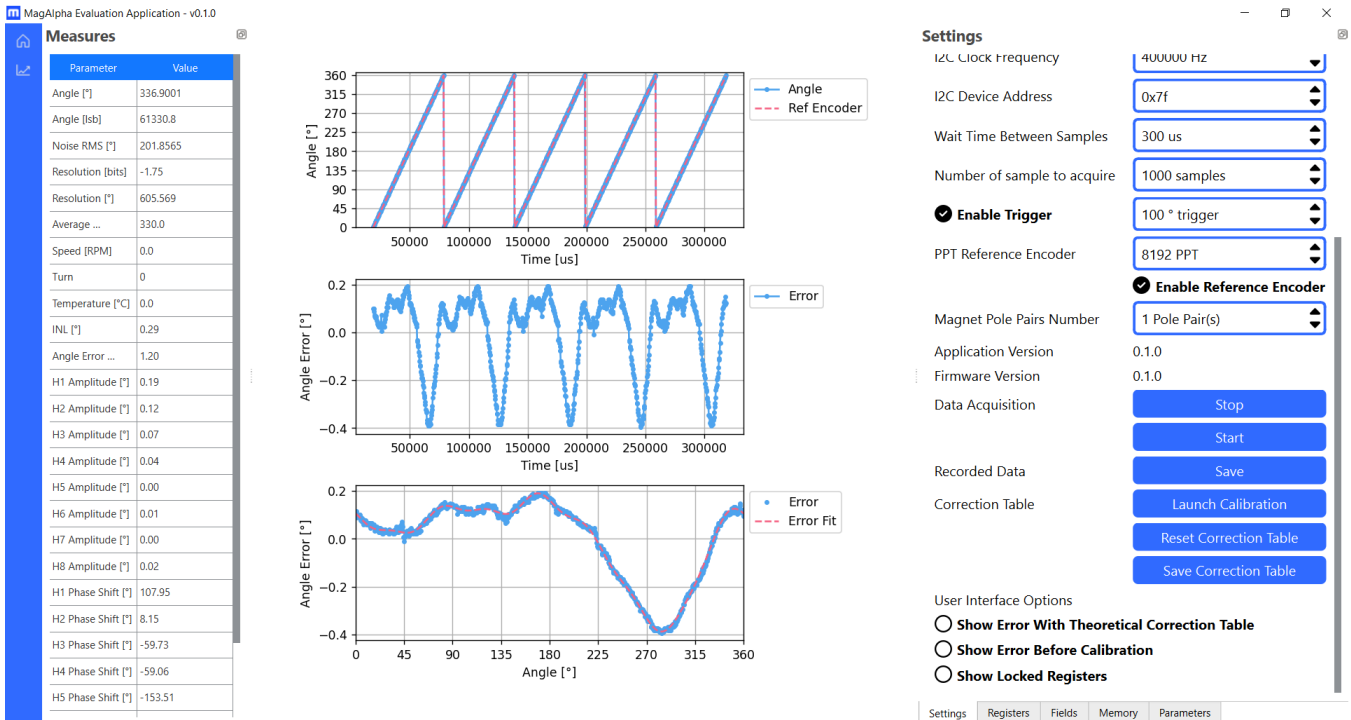

Figure 27: Before MA600 Calibration

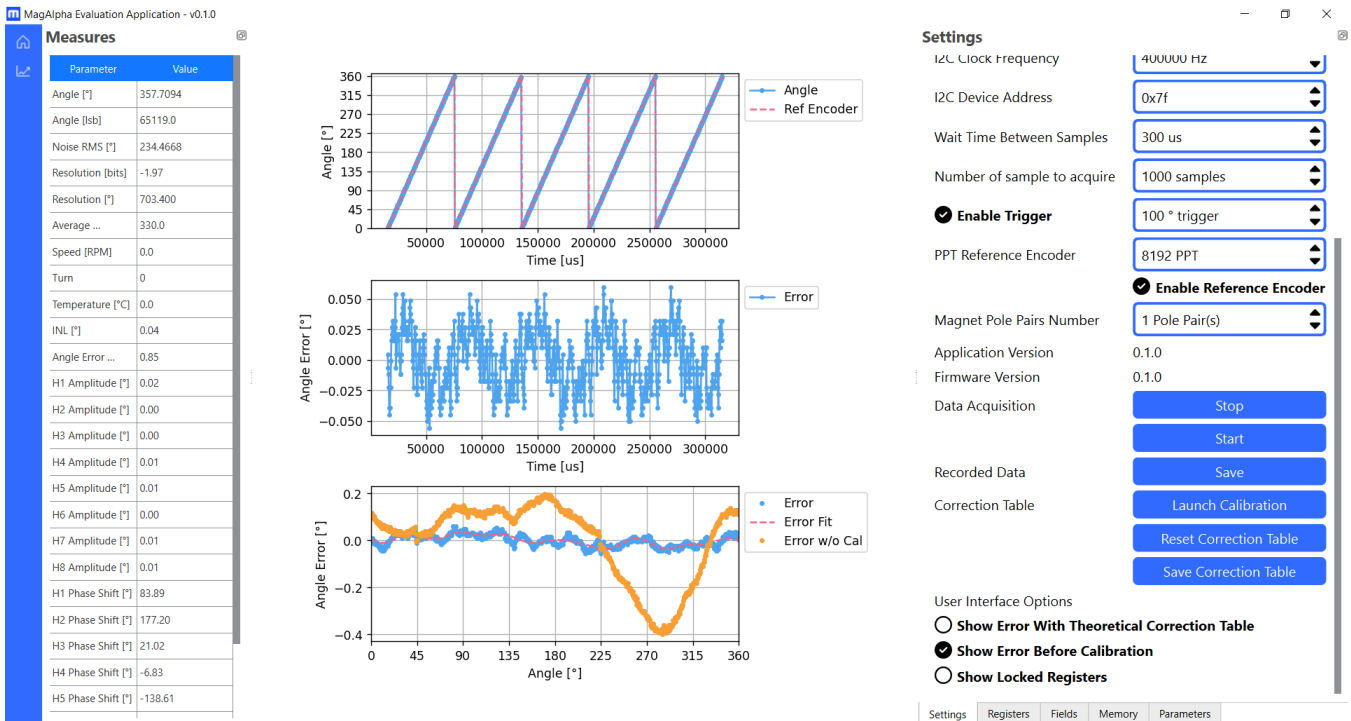

Figure 28: After MA600 Calibration



Section 3. Ordering Information

Part Number	Description
EVKT-MagAlpha-MagDiff	Complete evaluation kit
Boards Compatible with the Evaluation Kit	
TBMAxxx-Q-LT	All angle position sensor test boards
Online resources	Include GUI and supplemental documents

Order directly from MonolithicPower.com or our distributors.



REVISION HISTORY

Revision #	Revision Date	Description	Pages Updated
1.0	10/24/2023	Initial Release	-

Notice: The information in this document is subject to change without notice. Please contact MPS for current specifications. Users should warrant and guarantee that third-party Intellectual Property rights are not infringed upon when integrating MPS products into any application. MPS will not assume any legal responsibility for any said applications.