

20V N-Channel Enhancement-Mode MOSFET

RDS(ON), Vgs@2.5V, Ids@4.0A = 23mΩ

RDS(ON), Vgs@4.5V, Ids@4.0A = 19mΩ

Features

- High Power and current handling capability
- Lead free product is acquired
- Surface Mount Package

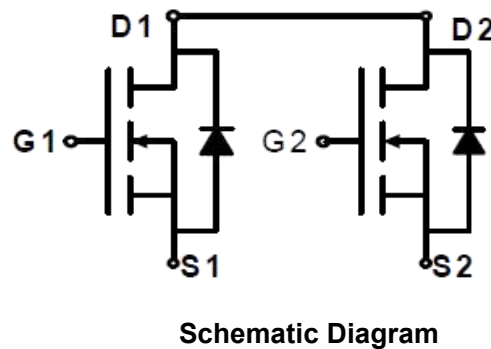
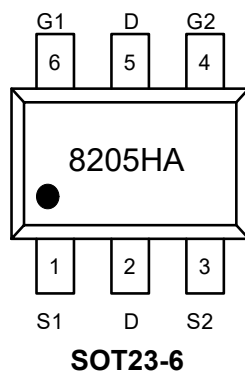

Absolute Max Ratings at Ta=25°C (Note1)

Parameter	Symbol	Maximum	Units
Drain to Source Voltage	VDSS	20	V
Gate to Source Voltage	VGSS	±12	V
Drain Current-Continuous	ID	6	A
Drain Current (Pulse)	IDM	20	A
Maximum Power Dissipation	PD	1.96	W
Operating Junction and Storage Temperature Range	Tj, Tstg	-55 to +150	°C
Lead Temperature for Soldering Purposes (1/8" from case for 10 s)	TL	260	°C

Note 1: Stresses exceeding those listed in the Maximum Ratings table may damage the device. If any of these limits are exceeded, device functionality should not be assumed, damage may occur and reliability may be affected.

Electrical Characteristics at Ta=25°C (Note 2)

Parameter	Symbol	Test Conditions	Min.	Typ.	Max.	Units
Drain to Source Breakdown Voltage	V(BR)DSS	ID = 250μA, VGS = 0V	19.5	20		V
Zero-Gate Voltage Drain Current	IDSS	VDS = 19V, VGS = 0V			1	μA
Gate-Body Leakage Current	IGSS	VGS = ±12V, VDS = 0V			±100	nA
Gate Threshold Voltage	VGS(th)	VDS=VGS, IDS=250μA	0.4	0.7	1.0	V
Drain to Source On-State Resistance	RDS(on)	ID = 4A, VGS = 4.5V	-	19	26	mΩ
		ID = 3A, VGS = 2.5V	-	23	30	mΩ
Input Capacitance	Ciss	VGS=0V,		375		pF
Output Capacitance	Coss	VDS=10V,		88		pF
Reverse Transfer Capacitance	Crss	Frequency=1.0MH		11		pF
Turn-ON Delay Time	td(on)	VDD = 10V, ID = 3A, VGS = 4.5V, RGEN = 10Ω		180		ns
Turn-ON Rise Time	tr			216		ns
Turn-OFF Delay Time	td(off)			35		ns
Turn-ON Fall Time	tf			164		ns
Total Gate Charge	Qg	VDS = 10V,		7.6		nC
Gate-Source Charge	Qgs	VGS = 4.5V,		3.0		nC
Gate-Drain Charge	Qgd	ID = 1A		1.5		nC
Diode Forward Voltage	VSD	IS = 4A, VGS = 0V	0.4	0.8	1.2	V

Note 2: Product parametric performance is indicated in the Electrical Characteristics for the listed test conditions, unless otherwise noted. Product performance may not be indicated by the Electrical Characteristics if operated under different conditions.

Typical electrical and thermal characteristics

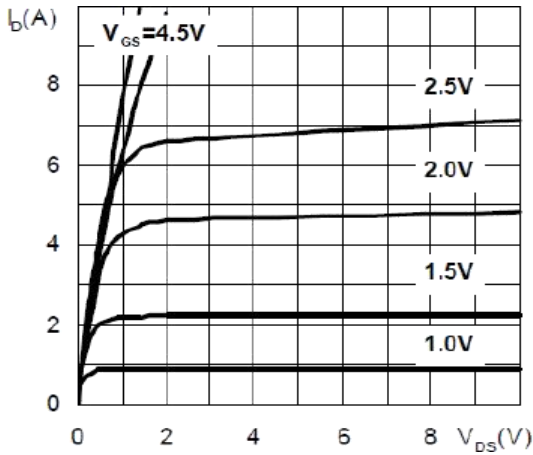

Figure 1 Output Characteristics

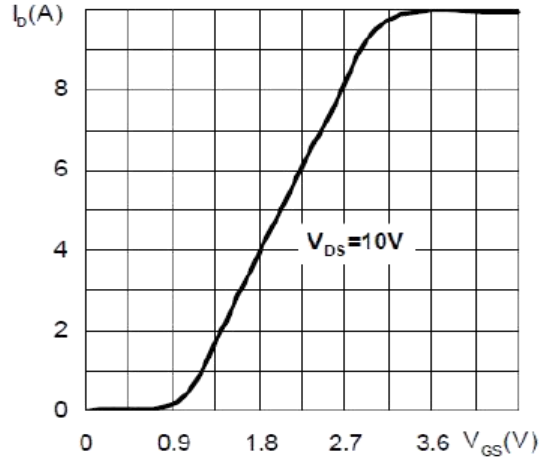

Figure 2 Transfer Characteristics

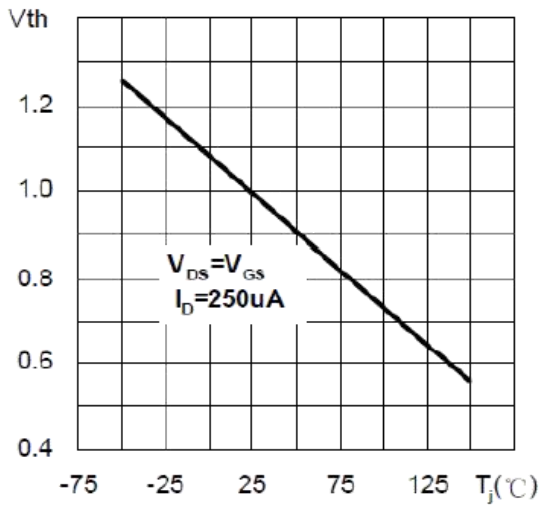

Figure 3 Thershold Voltage vs. Temperature

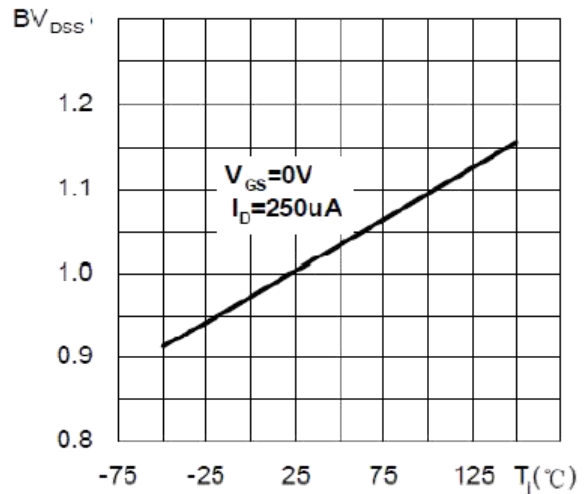

Figure 4 BVDSS vs. Temperature

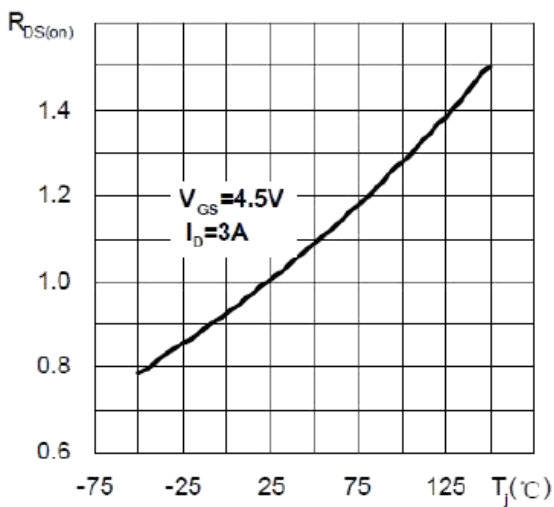

Figure 5 Rds(on) vs. Temperature

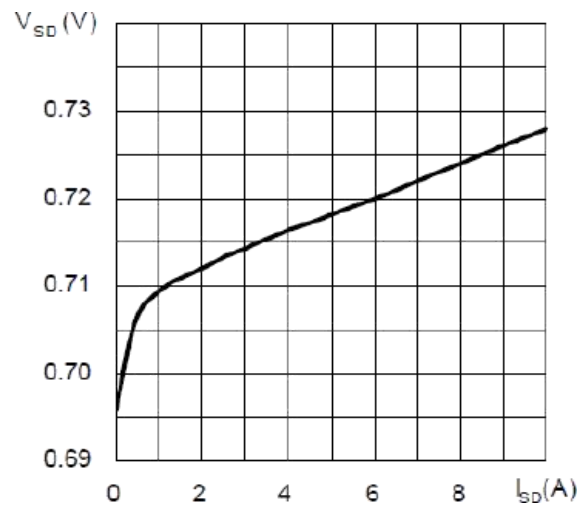

Figure 6 Source to Drain vs. Temperature

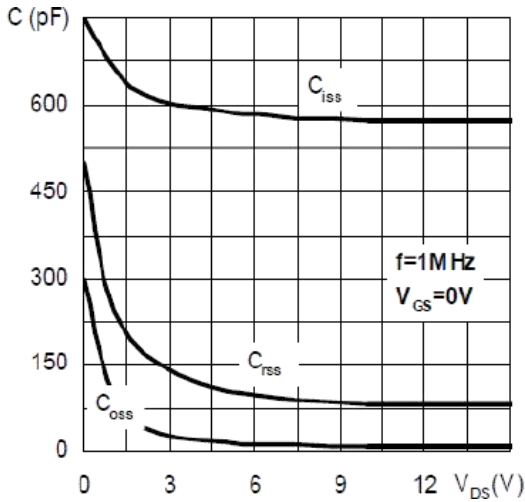

Figure 7 Capacitance

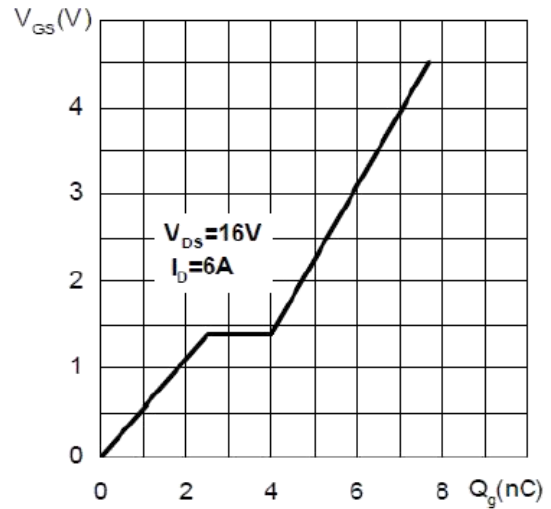

Figure 8 Gate Charge

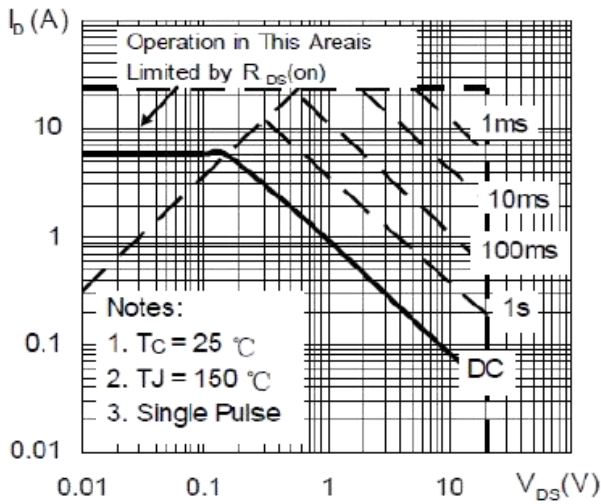

Figure 9 Safe Operating Area

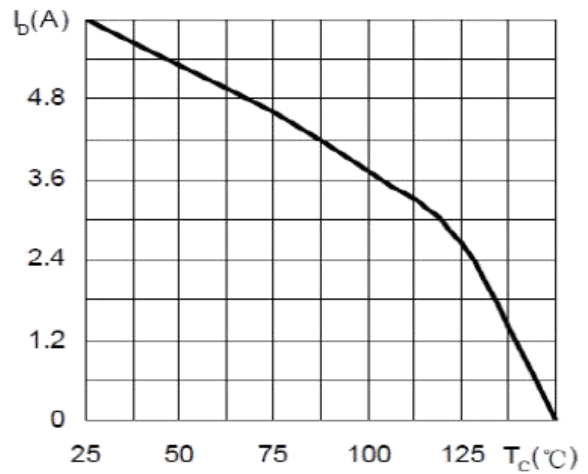

Figure 10 Maximum Drain Current vs. Case Temperature

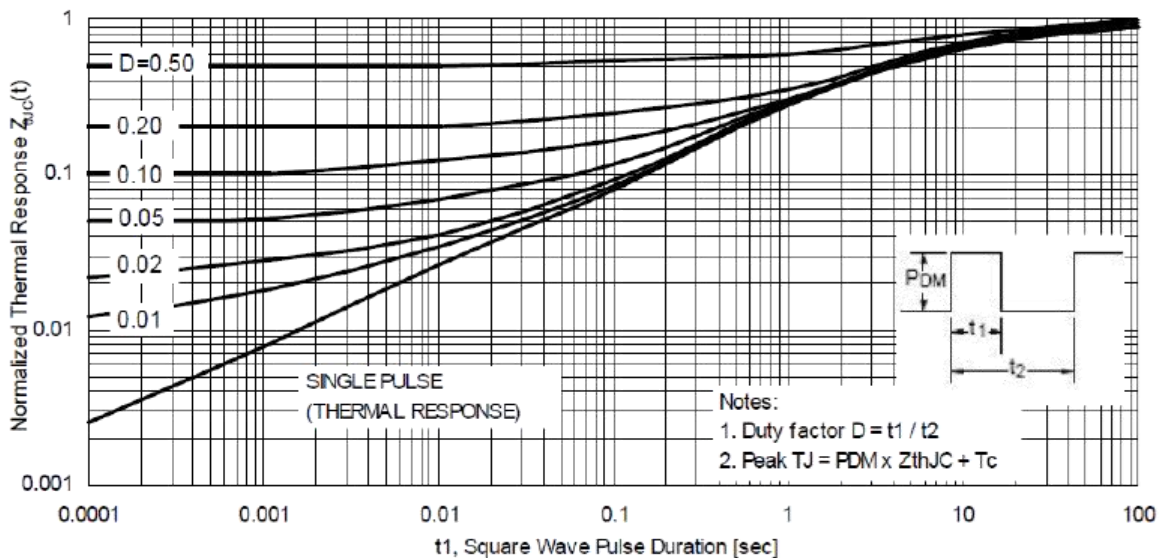
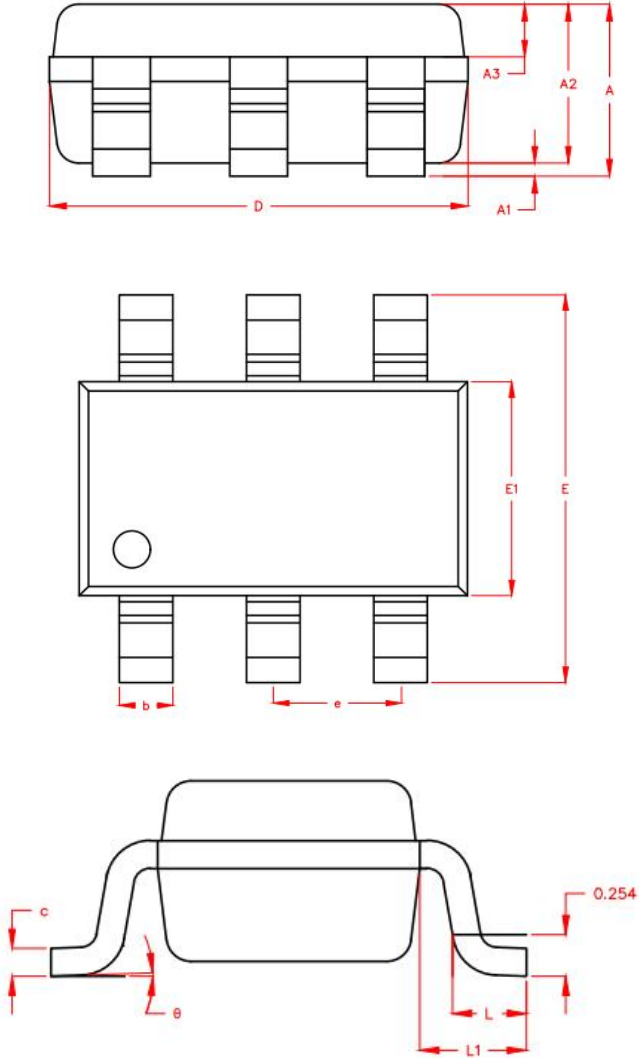

Figure 11 Maximum Transient Thermal Impedence

Package Dimensions

➤ SOT23-6



SYMBOL	MILLIMETER		
	MIN	NOM	MAX
A	1.14	1.19	1.24
A1	0	0.05	0.15
A2	1.05	1.10	1.15
A3	0.28	0.30	0.32
b	0.35	0.40	0.45
c	0.12	0.17	0.22
D	2.85	2.90	2.95
E	2.85	2.95	3.05
E1	1.55	1.60	1.65
e	0.95BSC		
L	0.30	0.45	0.60
L1	0.65BSC		
θ	0°	2°	8°