

N-Channel Enhancement Mode Power MOSFET

Description

The G80N03T uses advanced trench technology to provide excellent $R_{DS(ON)}$, low gate charge. It can be used in a wide variety of applications.

General Features

- V_{DS} 30V
- I_D (at $V_{GS} = 10V$) 90A
- $R_{DS(ON)}$ (at $V_{GS} = 10V$) < 4m Ω
- $R_{DS(ON)}$ (at $V_{GS} = 4.5V$) < 7m Ω
- 100% Avalanche Tested
- RoHS Compliant

Application

- Power switch
- DC/DC converters

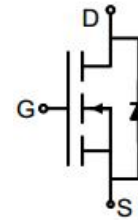

Schematic diagram



TO-220

Ordering Information

Device	Package	Marking	Packaging
G80N03T	TO-220	G80N03	50pcs/Tube

Absolute Maximum Ratings $T_C = 25^\circ\text{C}$, unless otherwise noted

Parameter	Symbol	Value	Unit
Drain-Source Voltage	V_{DS}	30	V
Continuous Drain Current	I_D	90	A
Pulsed Drain Current (note1)	I_{DM}	360	A
Gate-Source Voltage	V_{GS}	± 20	V
Power Dissipation	P_D	53.4	W
Single pulse avalanche energy (note2)	E_{AS}	81	mJ
Operating Junction and Storage Temperature Range	T_J, T_{stg}	-55 To 150	$^\circ\text{C}$

Thermal Resistance

Parameter	Symbol	Value	Unit
Thermal Resistance, Junction-to-Ambient	R_{thJA}	50	$^\circ\text{C/W}$
Maximum Junction-to-Case	R_{thJC}	2.34	$^\circ\text{C/W}$

Specifications $T_J = 25^\circ\text{C}$, unless otherwise noted						
Parameter	Symbol	Test Conditions	Value			Unit
			Min.	Typ.	Max.	
Static Parameters						
Drain-Source Breakdown Voltage	$V_{(BR)DSS}$	$V_{GS} = 0V, I_D = 250\mu A$	30	--	--	V
Zero Gate Voltage Drain Current	I_{DSS}	$V_{DS} = 30V, V_{GS} = 0V$	--	--	1	μA
Gate-Source Leakage	I_{GSS}	$V_{GS} = \pm 20V$	--	--	± 100	nA
Gate-Source Threshold Voltage	$V_{GS(th)}$	$V_{DS} = V_{GS}, I_D = 250\mu A$	1.0	1.5	2.0	V
Drain-Source On-Resistance	$R_{DS(on)}$	$V_{GS} = 10V, I_D = 25A$	--	3.6	4	m Ω
		$V_{GS} = 4.5V, I_D = 25A$	--	5.3	7	
Forward Transconductance	g_{FS}	$V_{GS} = 5V, I_D = 25A$	--	28	--	S
Dynamic Parameters						
Input Capacitance	C_{iss}	$V_{GS} = 0V,$ $V_{DS} = 15V,$ $f = 1.0\text{MHz}$	--	2150	--	pF
Output Capacitance	C_{oss}		--	335	--	
Reverse Transfer Capacitance	C_{rss}		--	312	--	
Total Gate Charge	Q_g	$V_{DD} = 15V,$ $I_D = 25A,$ $V_{GS} = 10V$	--	36	--	nC
Gate-Source Charge	Q_{gs}		--	6	--	
Gate-Drain Charge	Q_{gd}		--	8	--	
Turn-on Delay Time	$t_{d(on)}$	$V_{DD} = 15V,$ $I_D = 25A,$ $R_G = 6\Omega$	--	7	--	ns
Turn-on Rise Time	t_r		--	6	--	
Turn-off Delay Time	$t_{d(off)}$		--	29	--	
Turn-off Fall Time	t_f		--	8	--	
Drain-Source Body Diode Characteristics						
Continuous Body Diode Current	I_S	$T_C = 25^\circ\text{C}$	--	--	90	A
Body Diode Voltage	V_{SD}	$T_J = 25^\circ\text{C}, I_{SD} = 25A, V_{GS} = 0V$	--	--	1.2	V
Reverse Recovery Charge	Q_{rr}	$I_F = 25A, V_{GS} = 0V$ $di/dt=100A/us$	--	24	--	nC
Reverse Recovery Time	T_{rr}		--	45	--	ns

Notes

1. Repetitive Rating: Pulse width limited by maximum junction temperature
2. EAS condition : $T_J=25^\circ\text{C}$, $V_{DD}=30V, V_{GS}=10V, L=0.5\text{mH}, R_g=25\Omega$
The table shows the minimum avalanche energy, which is 225mJ when the device is tested until failure
3. Identical low side and high side switch with identical R_G

Gate Charge Test Circuit



Switch Time Test Circuit



EAS Test Circuit



Typical Characteristics $T_J = 25^\circ\text{C}$, unless otherwise noted

Figure 1. Output Characteristics

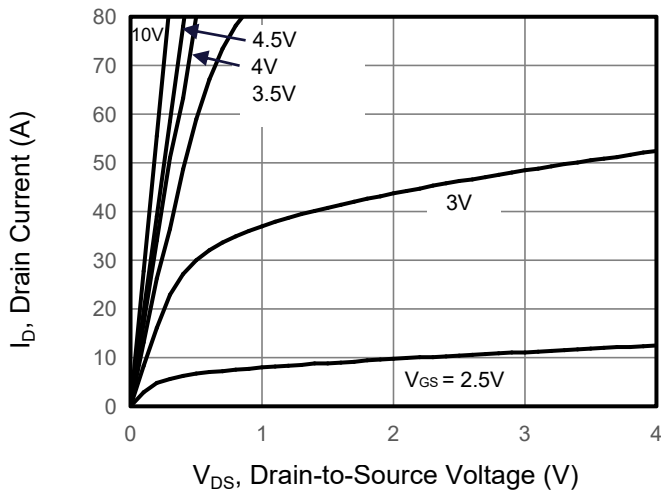

Figure 2. Transfer Characteristics

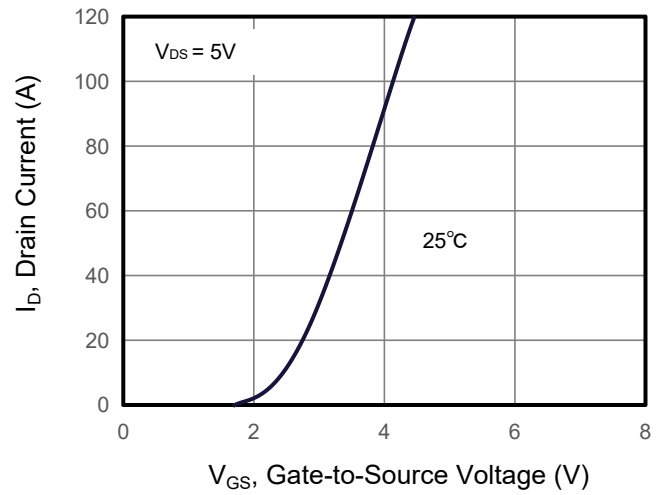

Figure 3. Drain Source On Resistance

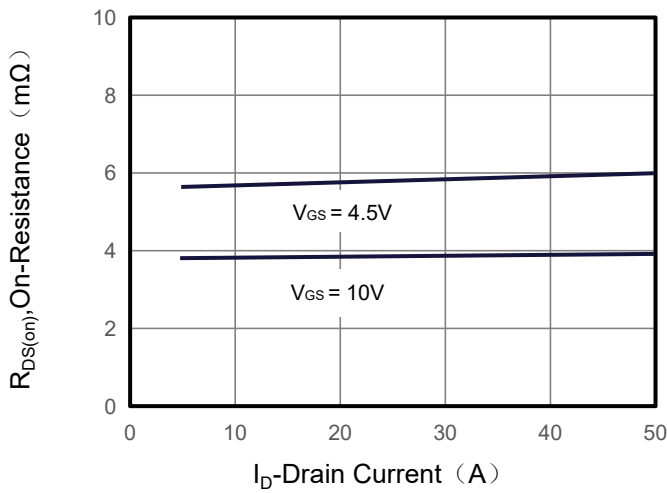

Figure 4. Gate Charge

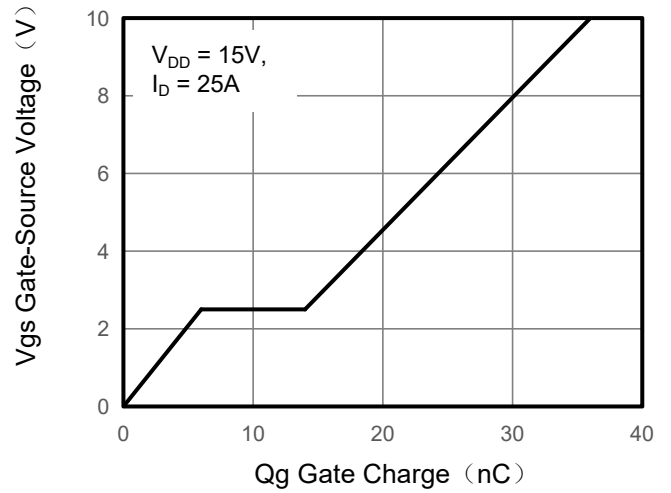

Figure 5. Capacitance

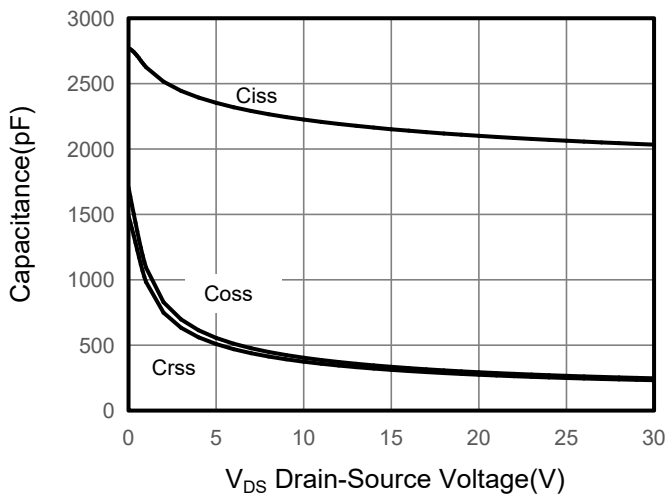
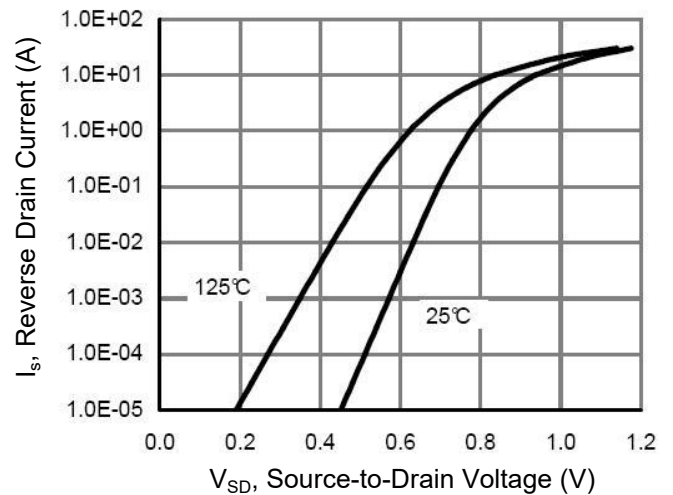

Figure 6. Source-Drain Diode Forward



Typical Characteristics $T_J = 25^\circ\text{C}$, unless otherwise noted

Figure 7. Drain-Source On-Resistance

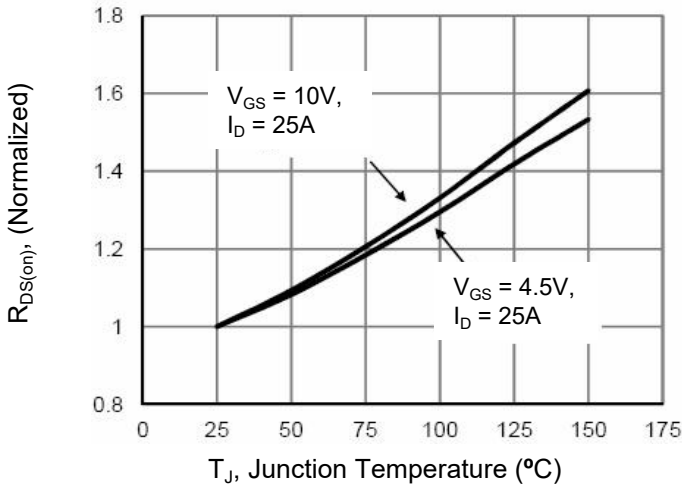

Figure 8. Safe Operation Area

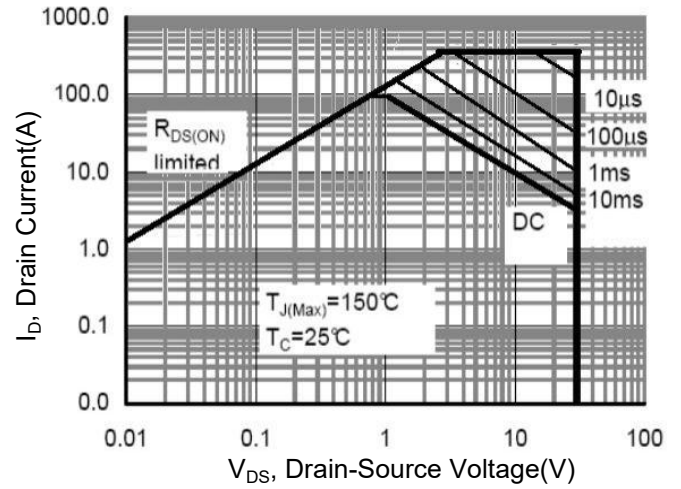
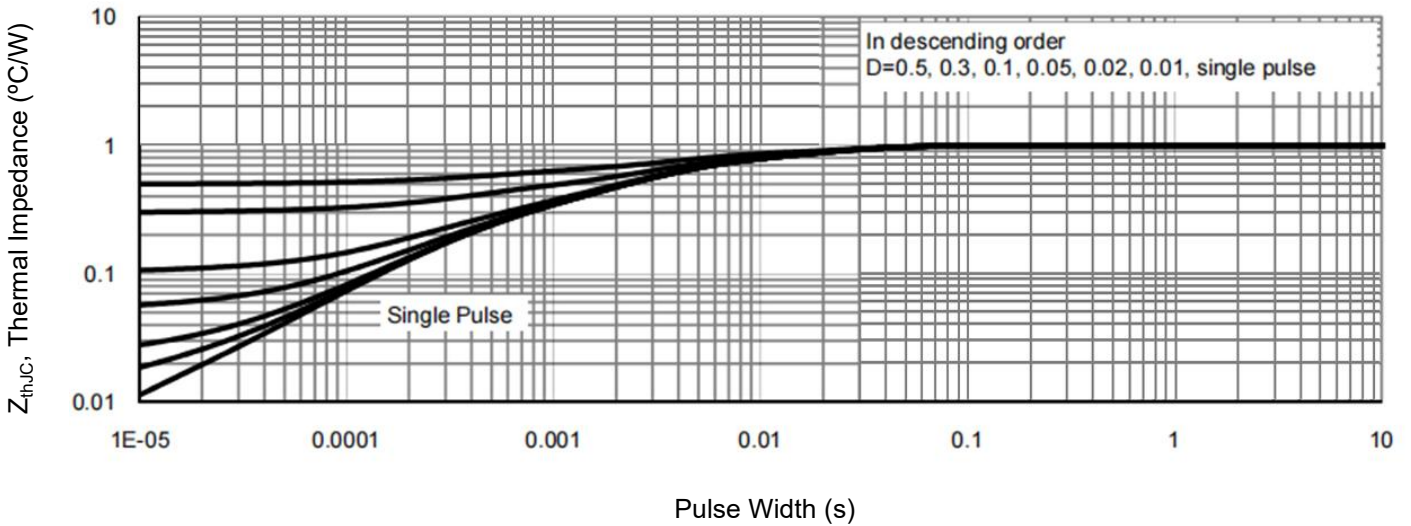
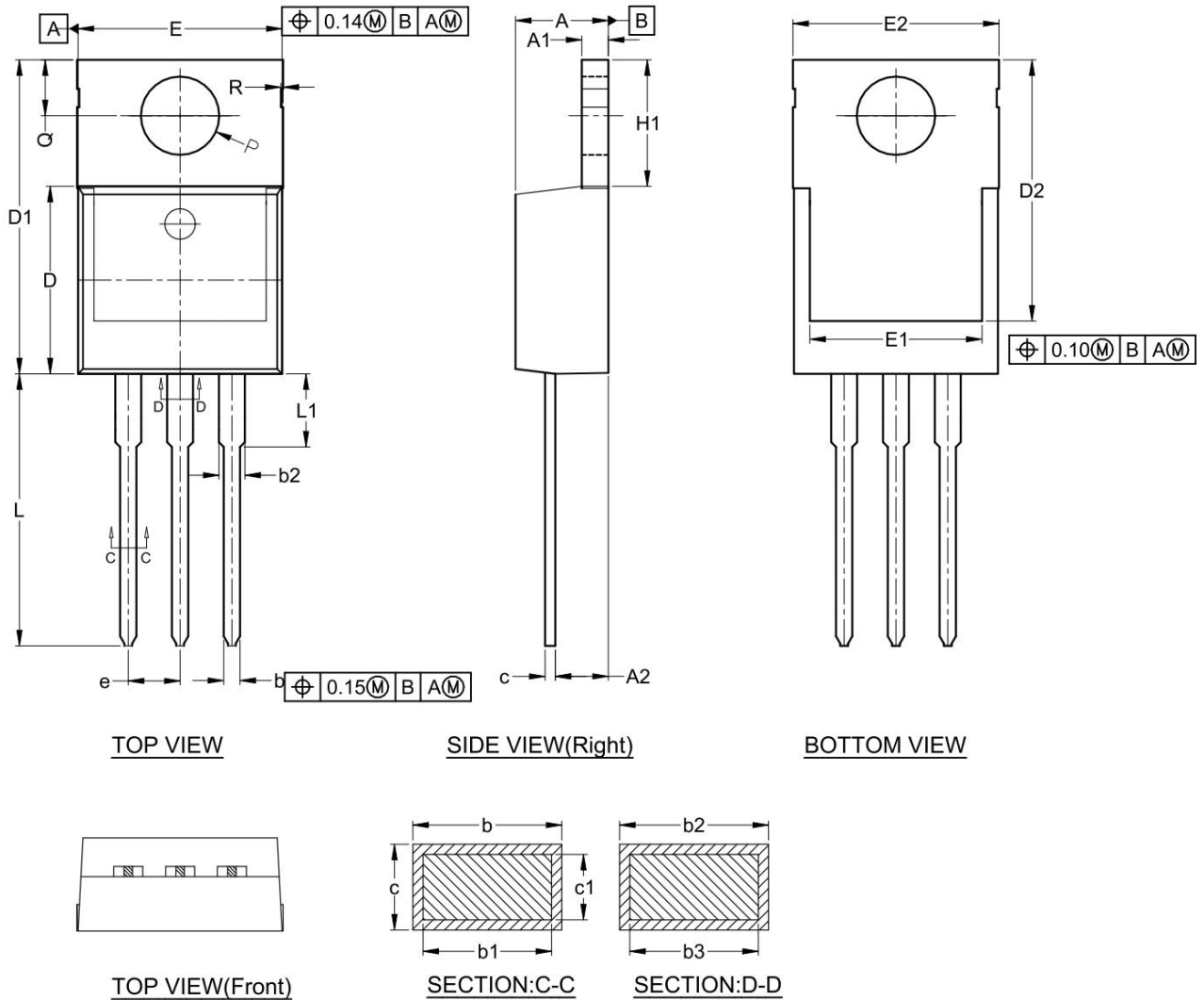

Figure 9. Normalized Maximum Transient Thermal Impedance



TO-220 Package Information



DIM SYMBOL	MIN.	NOM.	MAX.	DIM SYMBOL	MIN.	NOM.	MAX.
A	4.450	4.550	4.650	D2	12.610	12.810	13.010
A1	1.240	1.340	1.440	E	9.900	10.000	10.100
A2	2.500	2.600	2.700	E1	8.240	8.440	8.640
b	0.740	0.840	0.940	E2	9.900	10.100	10.300
b1	0.700	0.800	0.900	e	2.540 BSC.		
b2	1.210	1.310	1.410	H1	6.000	6.200	6.400
b3	1.170	1.270	1.370	L	13.140	13.340	13.540
c	0.440	0.540	0.640	L1	3.385	3.585	3.785
c1	0.400	0.500	0.600	ØP	3.740	3.840	3.940
D	9.100	9.200	9.300	Q	2.600	2.740	2.940
D1	15.200	15.400	15.600	R	0.108 REF.		