

74LVC1G08 Single 2-Input Positive-AND Gate

1. General Description

1.1 Description

This single 2-input positive-AND gate is designed for 1.65-V to 5.5-V VCC operation.

The 74LVC1G08 device performs the Boolean function or $Y = A \bullet B$ or $Y = \overline{A+B}$ in positive logic.

The CMOS device has high output drive while maintaining low static power dissipation over a broad VCC operating range.

1.2 Features

- Supports 5-V VCC Operation
- Inputs Accept Voltages to 5.5 V
- Provides Down Translation to VCC

- Low Power Consumption, 10 μ A Max ICC
- ± 24 mA Output Drive at 3.3V
- I_{off} Supports Live Insertion, Partial-Power-Down Mode, and Back Drive Protection

1.3 Device Information

PART NUMBER	PACKAGE
74LVC1G08	SOT23
	SC70
	SOT5X3
	DFN
	DSBGA

2. Connection Diagrams and Pin Description

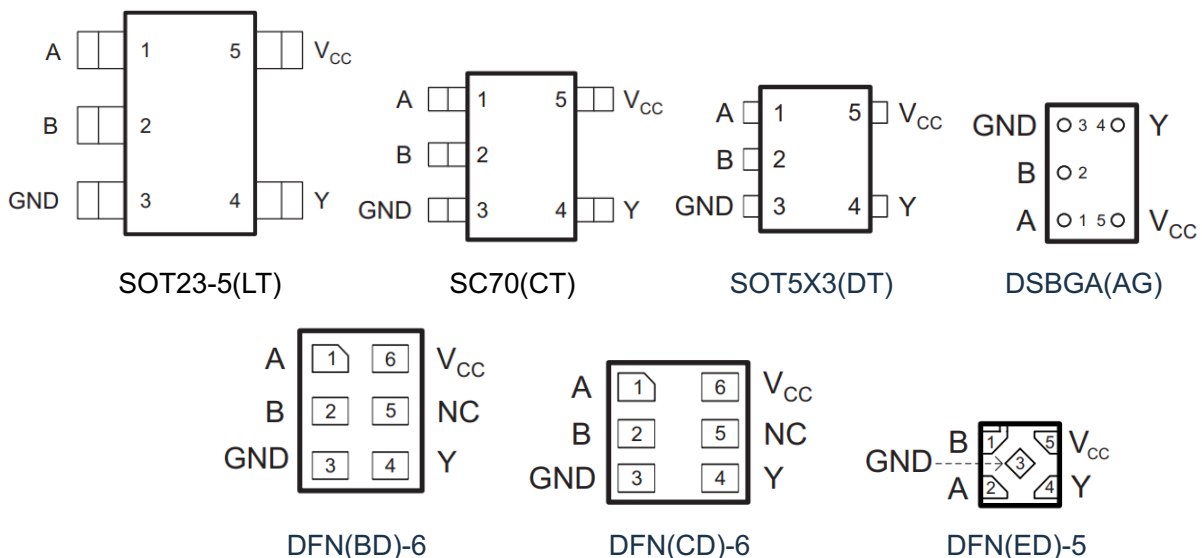

Figure 2.1: Top View

PIN No.			NAME	I/O	FUNCTION
LT/CT/DT/AG	BD/CD	ED			
1	1	2	A	I	Input
2	2	1	B	I	Input
3	3	3	GND		Ground
4	4	4	Y	O	Output
5	6	5	VCC		Supply Voltage
--	5	--	NC		No Connected

3. System Diagram

3.1 Logic Diagram



Figure 3.1: 74LVC1G08 Logic Diagram

3.2 Function Table

Input		Output
A	B	Y
1	1	1
0	X	0
X	0	0

X = don't care, 1=High State, 0=Low State,Z=High Impedance



4. Specifications

4.1 Absolute Maximum Ratings

Symbol	Parameter	MIN	MAX	Unit
V _{CC}	Supply Voltage	-0.5	6.5	V
V _I	Input Voltage Range	-0.5	6.5	V
V _O	Voltage Range(applied to any output in the high-impedance or power-off state) ⁽¹⁾	-0.5	6.5	V
	Voltage Range(applied to any output in the high or low state)	-0.5	V _{CC} + 0.5	V
I _O	Continuous Output Current		±50	mA
T _J	Junction Temperature		125	°C
T _{OP}	Operating Temperature	0	70	°C

Absolute maximum ratings are those values beyond which the device could be permanently damaged, These are stress ratings only, which do not imply functional operation of the device at these or any other conditions beyond those indicated under normal operating conditions.

- (1) The input and output negative-voltage ratings may be exceeded if the input and output current ratings are observed.

4.2 Electrical Characteristics

4.2.1 DC Specifications

(T_a=25°C, voltages are referenced to GND (ground=0V), All typical values are at V_{CC}=3.3V, unless otherwise specified)

Symbol	Parameter	Test Condition	MIN	TYP	MAX	Unit
V _{IH}	High Level Input Voltage	V _{CC} =1.65V to 1.95V	0.65V _{CC}	--	--	V
		V _{CC} =2.3V to 2.7V	1.7	--	--	V
		V _{CC} =3V to 3.6V	2.1	--	--	V
		V _{CC} =4.5V to 5.5V	0.7V _{CC}	--	--	V
V _{IL}	Low Level Input Voltage	V _{CC} =1.65V to 1.95V	--	--	0.35V _{CC}	V
		V _{CC} =2.3V to 2.7V	--	--	0.7	V
		V _{CC} =3V to 3.6V	--	--	0.8	V
		V _{CC} =4.5V to 5.5V	--	--	0.3V _{CC}	V
I _{OH}	High Level Output Current	V _{CC} =1.65V	--	--	-4	mA
		V _{CC} =2.3V	--	--	-8	mA
		V _{CC} =3V	--	--	-16	mA
		V _{CC} =4.5V	--	--	-32	mA
I _{OL}	Low Level Output Current	V _{CC} =1.65V	--	--	4	mA
		V _{CC} =2.3V	--	--	8	mA
		V _{CC} =3V	--	--	16	mA
		V _{CC} =4.5V	--	--	24	mA
		V _{CC} =4.5V	--	--	32	mA



Symbol	Parameter	Test Condition	MIN	TYP	MAX	Unit
V_{OH}	High Level Output Voltage	$V_{CC}=1.65V$ to $5.5V, I_{OH}=-100\mu A$	$V_{CC}-0.1$	--	--	V
		$V_{CC}=1.65V, I_o=-4mA$	1.2	--	--	V
		$V_{CC}=2.3V, I_o=-8mA$	1.9	--	--	V
		$V_{CC}=3V, I_o=-16mA$	2.4	--	--	V
		$V_{CC}=3V, I_o=-24mA$	2.3	--	--	V
		$V_{CC}=4.5V, I_o=-32mA$	3.8	--	--	V
V_{OL}	Low Level Output Voltage	$V_{CC}=1.65V$ to $5.5V, I_{OH}=100\mu A$	--	--	0.1	V
		$V_{CC}=1.65V, I_o=4mA$	--	--	0.45	V
		$V_{CC}=2.3V, I_o=8mA$	--	--	0.3	V
		$V_{CC}=3V, I_o=16mA$	--	--	0.4	V
		$V_{CC}=3V, I_o=24mA$	--	--	0.55	V
		$V_{CC}=4.5V, I_o=32mA$	--	--	0.55	V
I_i	A or B Inputs Leakage Current	$V_{CC}=0$ to $5.5V, V_i=V_{CC}$ or GND	--	0	± 5	μA
I_{off}	Power Off Leakage Current	$V_{CC}=0V, V_i$ or $V_o=5.5V$	--	0	± 10	μA
I_{CC}	Quiescent Supply Current	$V_{CC}=1.65V$ to $5.5V, V_i=V_{CC}$ or GND, $I_o=0$	--	0	10	μA
ΔI_{CC}	Additional Quiescent Supply Current Per Input Pin	$V_{CC}=3V$ to $5.5V$, one input at $V_{CC}-0.6V$, Other inputs at V_{CC} or GND	--	--	500	μA

5. Application Information

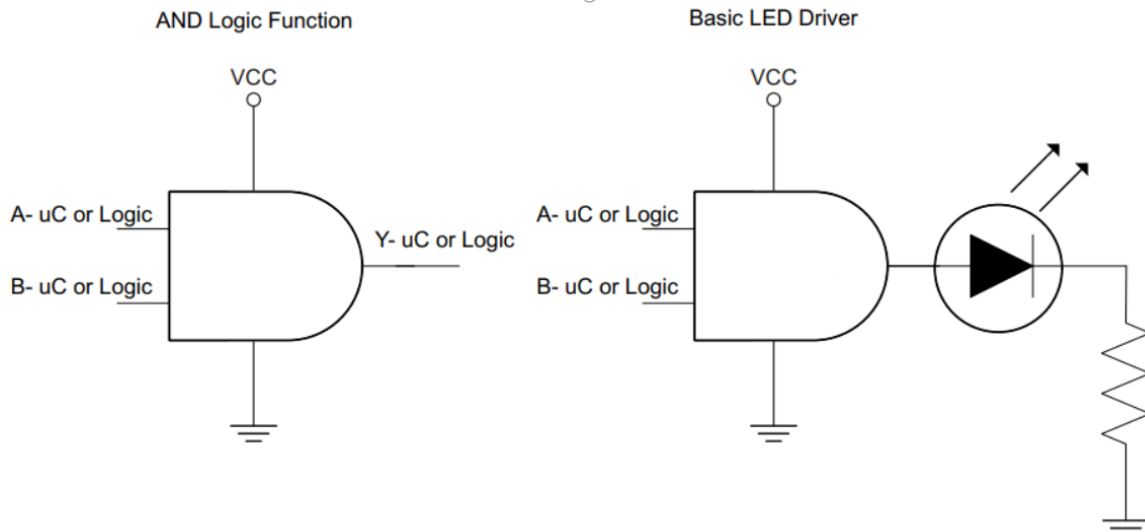

Figure 5.1: Application Schematic



6. Ordering Information

Orderable Device	Package Type	Pins	Packing	Package Qty
74LVC1G08LT05ARCQ	SOT23	5	Tape & Reel	3000
74LVC1G08CT05ARCQ	SC70	5	Tape & Reel	3000
74LVC1G08DT05ARDQ	SOT5x3	5	Tape & Reel	4000
74LVC1G08BD06AREQ	DFN(BD)	6	Tape & Reel	5000
74LVC1G08CD06AREQ	DFN(CD)	6	Tape & Reel	5000
74LVC1G08ED05ARCQ	DFN	5	Tape & Reel	3000
74LVC1G08AG05ARCQ	DSBGA	5	Tape & Reel	3000

7. Package Information

7.1 SOT23-5

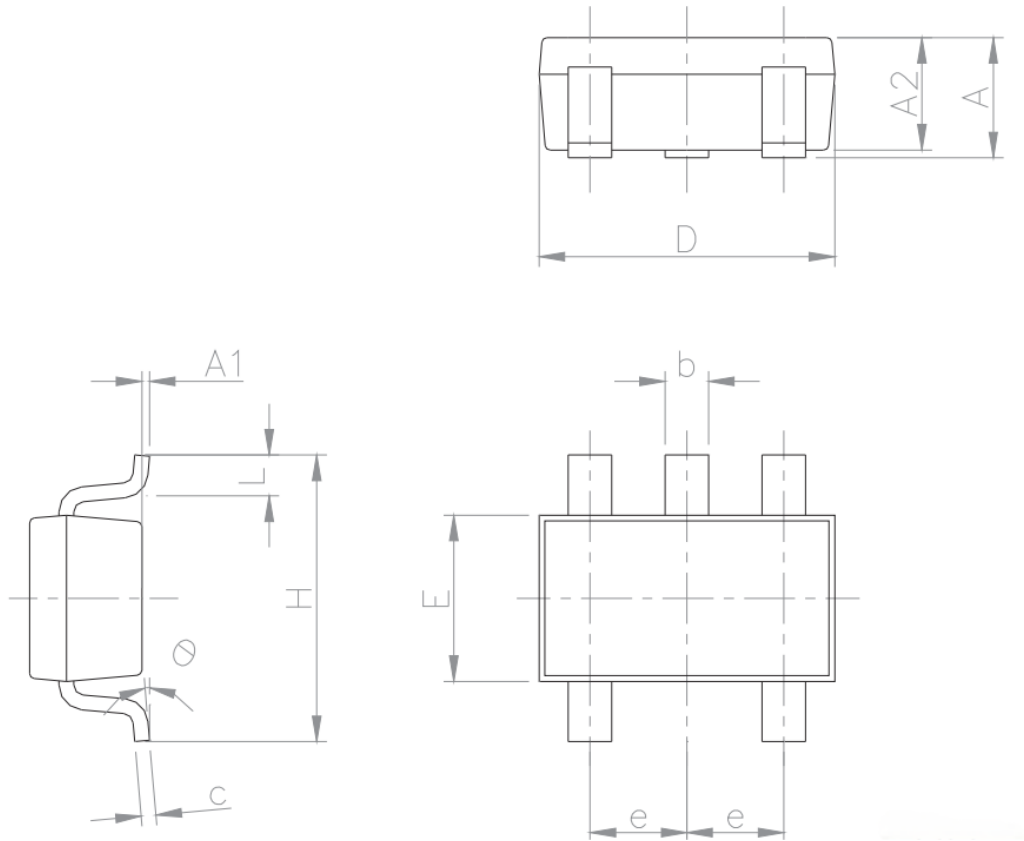

Symbol	Dimensions					
	Millimeters			Inches		
	Min.	Typ.	Max.	Min.	Typ.	Max.
A	0.90	-	1.45	0.035	-	0.057
A1	-	-	0.15	-	-	0.006
A2	0.90	-	1.30	0.035	-	0.051
b	0.35	-	0.50	0.014	-	0.020
c	0.09	-	0.20	0.004	-	0.008
D	2.80	-	3.05	0.110	-	0.120
E	1.50	-	1.75	0.059	-	0.069
e	-	0.95	-	-	0.037	-
H	2.60	-	3.00	0.102	-	0.118
L	0.10	-	0.60	0.004	-	0.024
θ	0 degrees	-	10 degrees	-	-	-



7.2 SC70

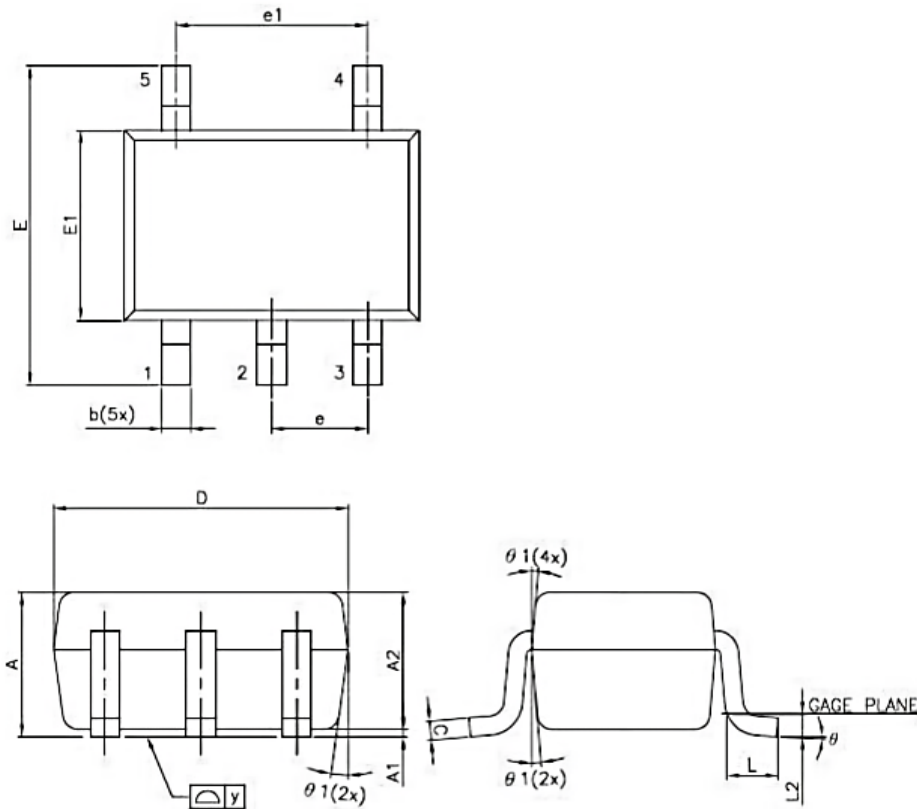

Symbol	Dim in mm		
	MIN	TYP	MAX
A	0.90	1.00	1.10
A1	0.00	0.05	0.10
A2	0.90	0.95	1.00
b	0.15	0.25	0.35
C	0.10	0.12	0.15
D	1.80	2.00	2.20
E	2.15	2.25	2.35
E1	1.15	1.25	1.35
e	0.650TYP.		
el	1.20	1.30	1.40
L	0.25	0.30	0.40
L2	0.15TYP.		
Y	0.00	0.05	0.10
theta	4°	8°	12°

7.3 SOT5X3

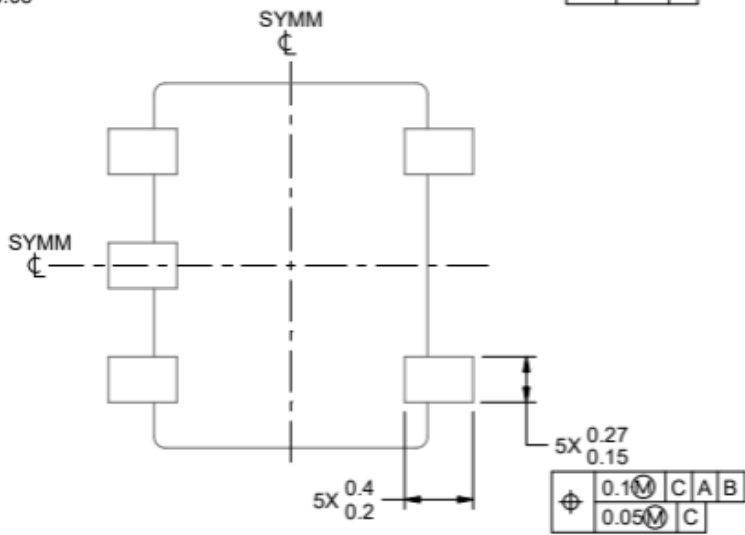
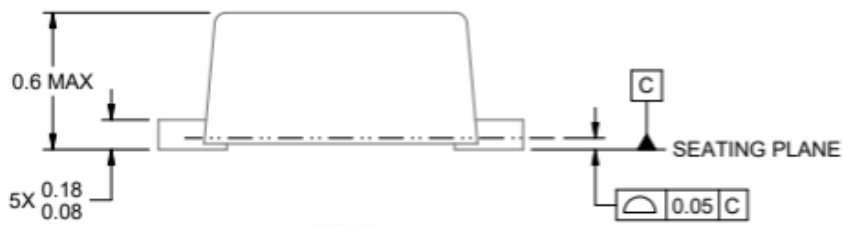
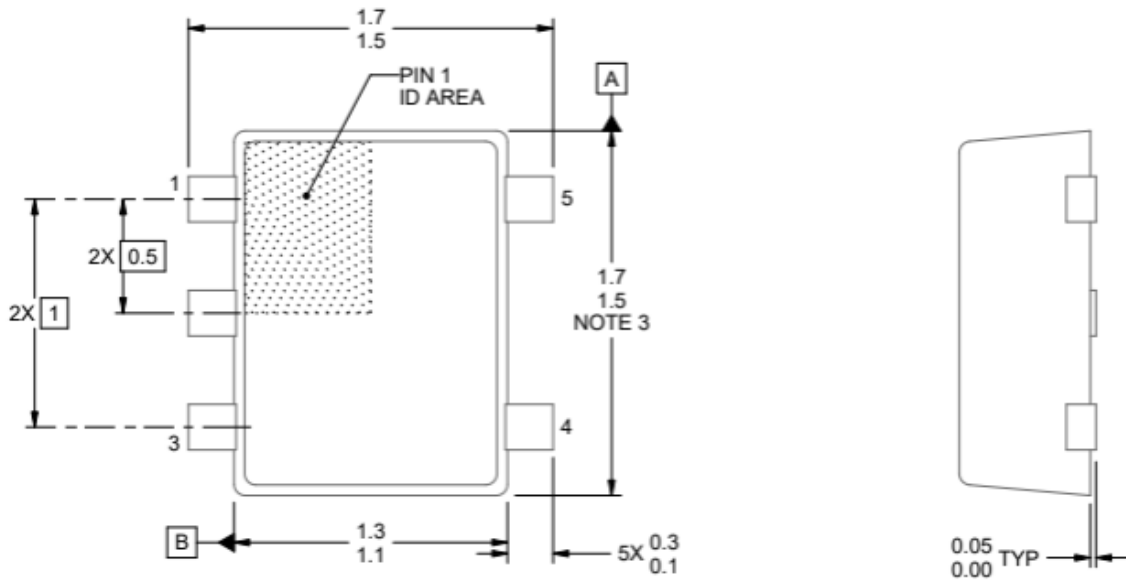

7.4 DFN(BD)-6

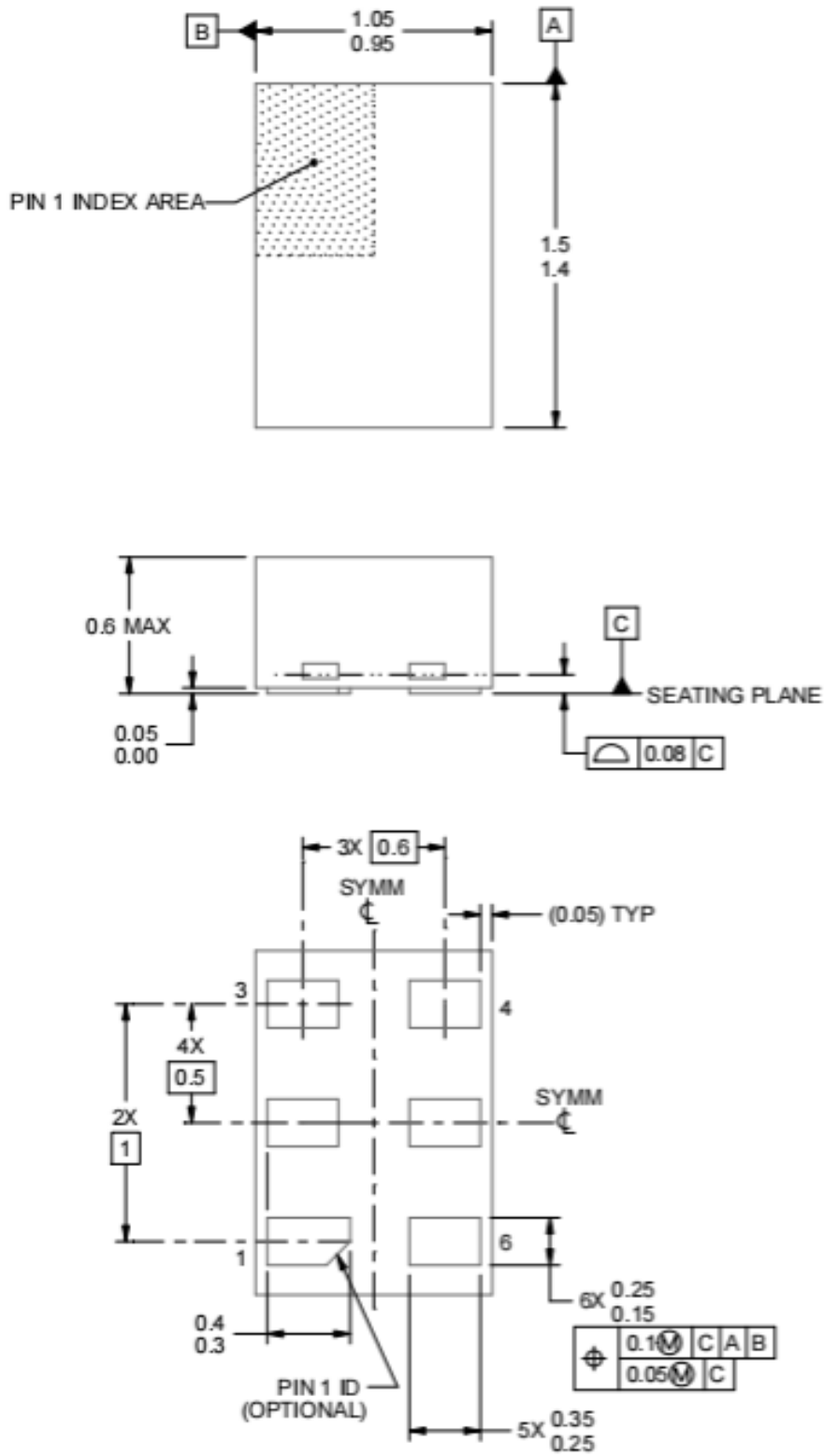

7.5 DFN(CD)-6

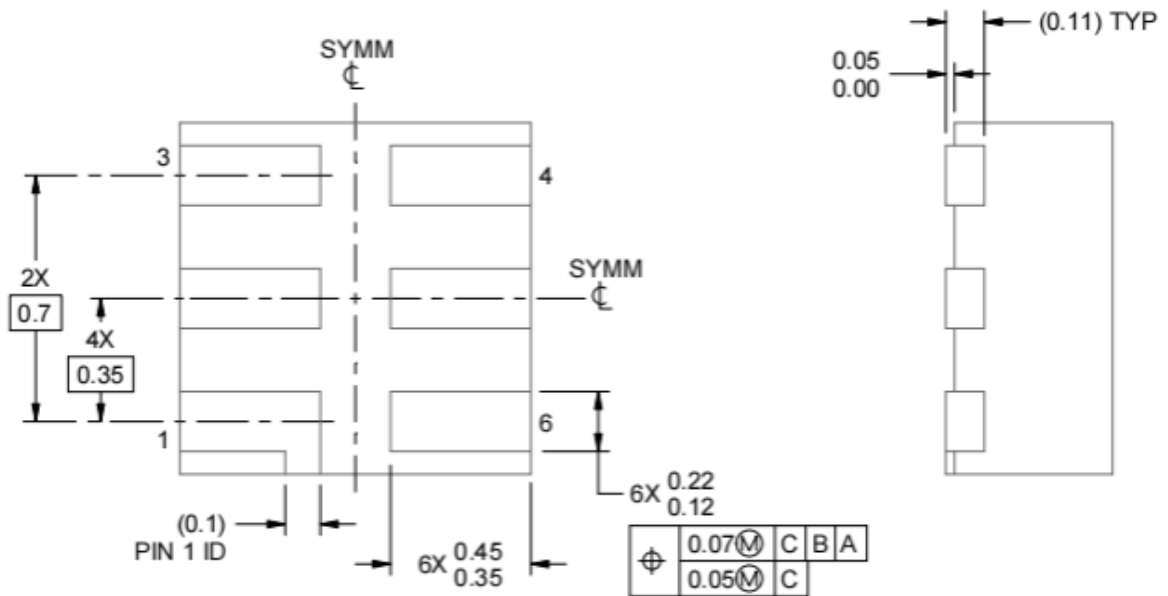
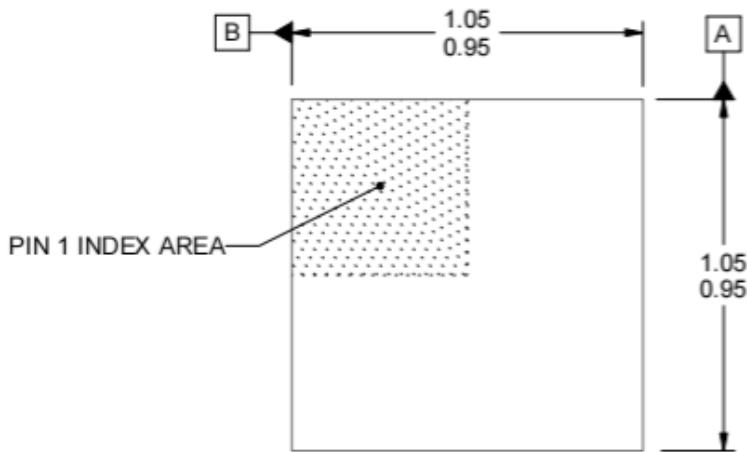

7.6 DFN5

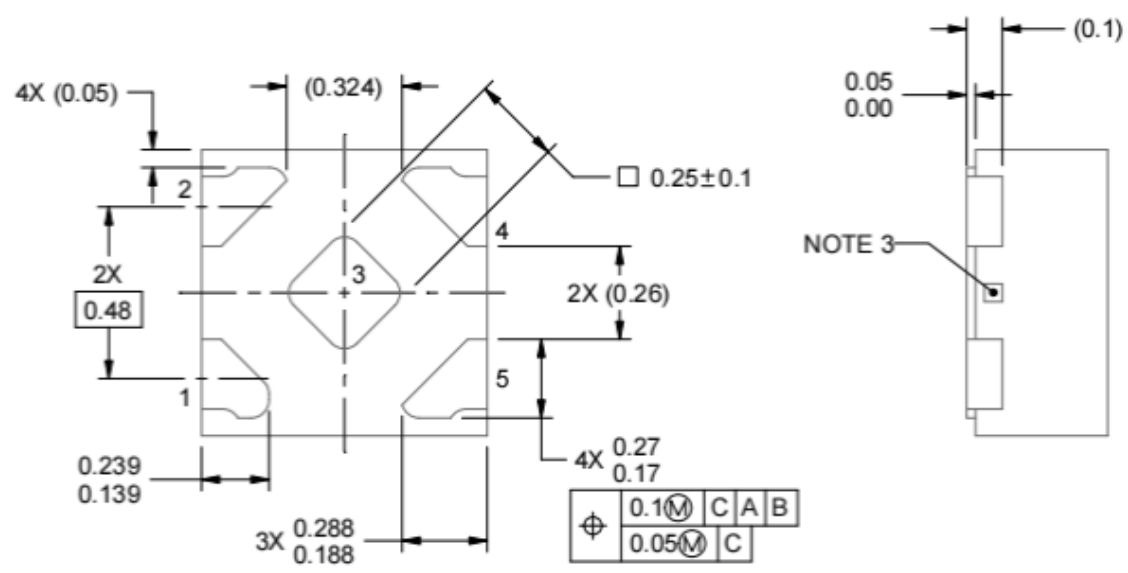
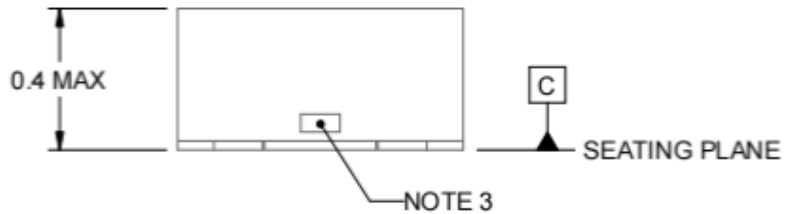
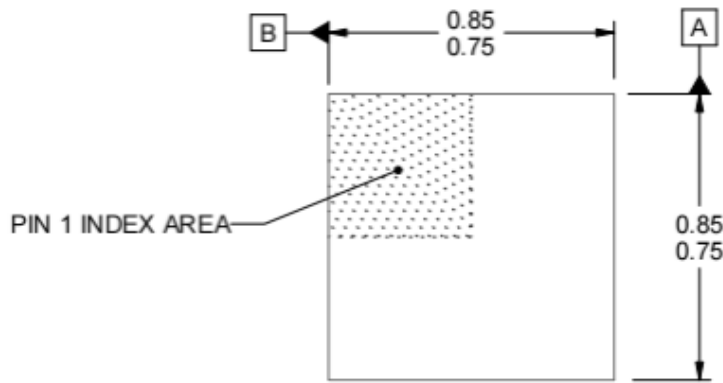

7.7 DSBGA

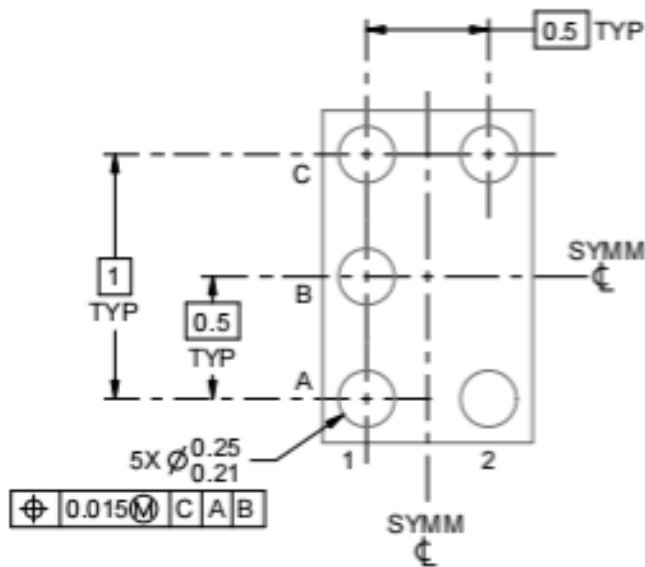
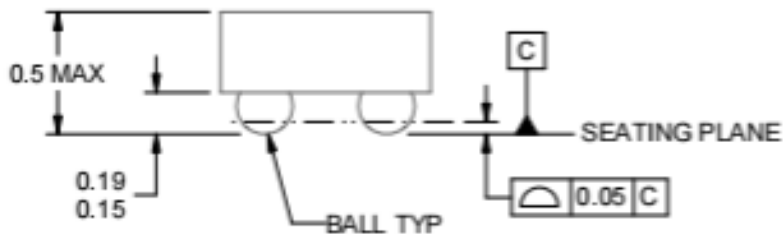
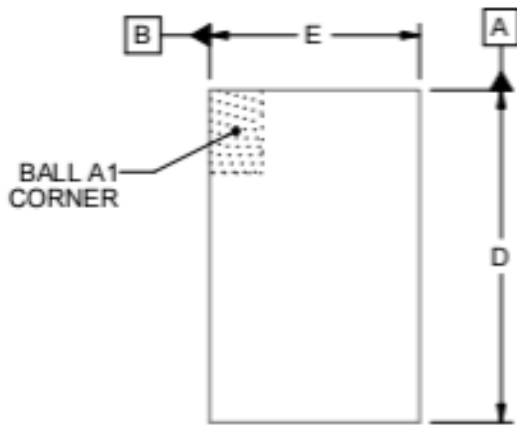

D: Max = 1.418 mm, Min = 1.358 mm
 E: Max = 0.918 mm, Min = 0.858 mm