

规格承认书

APPROVAL SHEET

客户名称/ Customer _____

客户料号/ USER P/N _____

品名/DESCRIPTION DC 风扇 _____

产品型号/MODEL No. JC6025B24UC2 _____

产品编号/NOT NUMBER. JC6025B24UC2-24052203 _____

制做日期/ISSUE DATE 2024.05.22 _____

制表 DRAWN	检查 CHECKED	审核 APPROVED	版本 REVISION
孙泽程	李继炳	刘其浩	A1.0

客户承认/ CUSTOMER APPROVAL

深圳市健策电子有限公司

SHENZHEN JENTECH ELECTRONIC CO., LTD

深圳市龙华区桂月路 306 号仪表世界工业区 6 栋 4 楼

TEL: 0755-23706799 FAT: 0755-23707879

www.jentech.cn

1. 版本记录 (Revised Record)

序号 No.	版本 REV	修改描述 Devision Description	日期 Date	备注 Note
1	A1.0	初版	240522	

2. 一般规格 (General Specification)

项目 Item		规格/条件 Specification/Condition		
1	型号 Model No.	JC6025B24UC2		
2	外型尺寸 Outline. Dimension	60*60*25mm		
3	工作电压 Operating Voltage	DC21.6~26.4V		
4	额定电压 Rated .voltage	DC24V		
5	启动电压 Starting Voltage	DC ≤12V on/off		
6	额定电流 Rated current	0.57A ±10%	a. 额定电压 Rated .voltage b.25°C 65% RH c.After testing for 5 minutes	
7	消耗功率 Power consumption	13.68W ±10%		
8	转速 Speed	12000RPM ±10%		
9	风量 Airflow AT ZERO STATIC PRESSURE	54.4	CFM	a. 额定电压 Rated .voltage b. AMCA 标准 Standard C. 额定电流 Rated current
	静压 Air .Static Pressure AT ZERO AIRFLOW	1.54	m³/min	
		1.428	inch-H ₂ O	
		355.57	Pa	
10	噪音标准 Noise Level	55.2dB-A		a. 额定电压 Rated Voltage b. 18dB无响室 18dB Non-Echo Chamber c. 标准 Standard: CNS 8753 / ISO 3744 d. Test Condition :ISO 7779 e. 距离 Distance: 1.0 M
11	期望寿命 Life expectancy	70000 hrs at temp40°C Humidity5% ~ 95%		MTTF Mean Time To Failure Conf. Level 90%
12	扇叶数 No.of.Blade	9 叶		
13	极数 No.of.Pole	4 极/Poles		
14	运转方向 Rotating Direction	顺时针/Clockwise (从标签面看/From Label side)		

3. 电气规格 (Electrical Specification)

1	锁住保护 Lock Roteor Protection	<input checked="" type="checkbox"/>	风扇停转后,风扇会在2至6秒自动尝试启动 After auto power off, circuit attempt to restart in 2 to 6 sec.		
		<input checked="" type="checkbox"/>	额定电压下堵转2~3秒,风扇自动断电,停止运转,降低内部温升 Auto power off after locked at rated voltage for 2~3 sec. Reduce internal temperature rise		
2	极性保护 Polarity Protection	<input checked="" type="checkbox"/>	VCC与GND反接时 不导通 pen circuit when Vcc & GND are exchanged		
3	过压保护 Over voltage protelt	<input type="checkbox"/>	无/NO	<input type="checkbox"/>	是/YES
4	过流保护 Over current protection	<input type="checkbox"/>	无/NO	<input type="checkbox"/>	是/YES
5	RD 信号 Receive delay	<input type="checkbox"/>	无/NO	<input type="checkbox"/>	是/YES
6	FG 信号 First Grade	<input type="checkbox"/>	无/NO	<input checked="" type="checkbox"/>	是/YES
7	恒速功能 fixed constant speed Function	<input type="checkbox"/>	无/NO	<input type="checkbox"/>	是/YES
8	软启动 Soft Starting	<input type="checkbox"/>	无/NO	<input checked="" type="checkbox"/>	是/YES
9	PWM 功能 PWM function	<input type="checkbox"/>	无/NO	<input checked="" type="checkbox"/>	是/YES
10	绝缘阻抗 Insulation Resistance	10MΩ/裸线 与外框间测量, 500VDC/min 10MΩ/between unshackled wire and frame at 500VDC/min			
11	绝缘耐压 Dielectric Strength	5Ma Max./导线 与外框间测量, 500VAC/min 5Ma Max./Measured between lead wire(+)and frame at 500VAC/min			
12	防水等级 Waterproof level	无/NO		IPXX protection verification is focused on motor and PCB, not for power connector and pin hosing	

4. 主要材料/零件规格 (Main Materials/parts Specification)

1	轴承/Bearng	<input checked="" type="checkbox"/>	双滚珠轴承 (Dual Ball Bearing)	<input type="checkbox"/>	含油轴承 (Sleeve Bearing)	<input type="checkbox"/>	液压轴承 (Hydraulic Bearing)	
2	外框材质/Frame	<input checked="" type="checkbox"/>	PBT of UL94V-0.			<input type="checkbox"/>	Die-cast Aluminum alloy	
3	扇叶材质 /Impeller	<input checked="" type="checkbox"/>	PBT of UL94V-0.			<input type="checkbox"/>	Steel	
4	绝缘套/Bobbin	<input checked="" type="checkbox"/>	PBT of UL94V-0.					
5	导线/Lead Wire	<input checked="" type="checkbox"/>	Red (+)	<input checked="" type="checkbox"/>	Black (-)	<input checked="" type="checkbox"/>	Blue (PWM)	UL1007 26#
		<input checked="" type="checkbox"/>	Yellow (FG)	<input type="checkbox"/>	White (RD)		4 wires 300±10mm	
6	端子/Connector	无/NO						
7	套管/Tube	无/NO						

5. 环境测试 (Environmental Specification)

1	运转温/湿度范围 Operating Temp .Range	温度/Temperature:-20°C ~ +75°C 湿度/Humidity:5% ~ 95%RH
2	保存温/湿度范围 Storage Temperature	温度/Temperature:-40°C ~ +85°C 湿度/Humidity:5% ~ 95%RH

6. 噪音测试 (Noise is measured at rated voltage in anechoic)

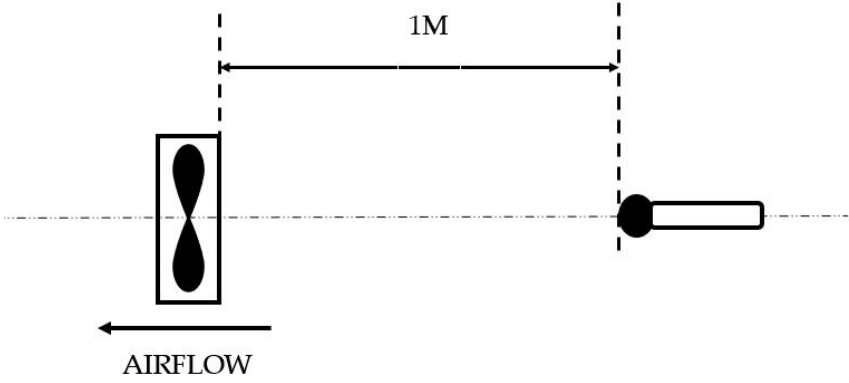

在背景噪音不超过 18dB (A) 的无响室内，将待测风扇通入额定的工作电压，悬掉入空中，将麦克风放于风扇同一平面且离待测风扇进风口一米处进行测试其 B&K 值

Noise is measured rated voltage in free air in anechoic chamber with B&K sound level meter with microphone at a distance of one meter from the fan intake.The background noise is 18Db(A) max.

7. 商标 (Label Marking)



8. 外形尺寸 (Outline Dimenson)

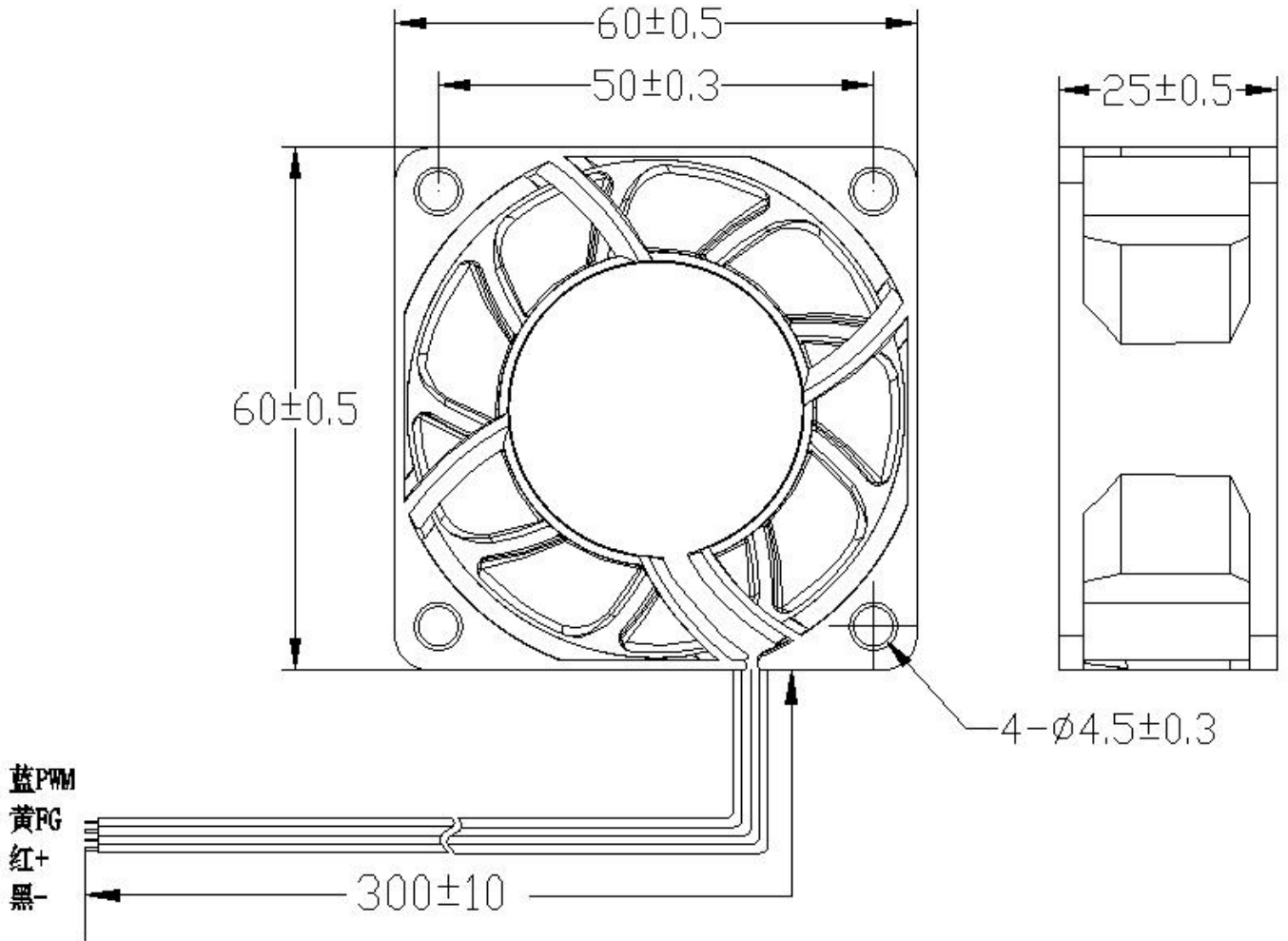

9. 转速检测 (Frequency Generator)

- (1) 三极管 “导通” 状态/Transistor at “ON” position
 - 集电极电流/Collector Current $I_c = 10\text{mA max}$
 - 饱和导通电压/Saturation Voultage $V_{ol} = 1\text{V max}$
- (2) 三极管 “截止” 状态/Transistor at “OFF” position
 - 开路电压/Release Voultage $V_{oH} \leq V_{cc}$

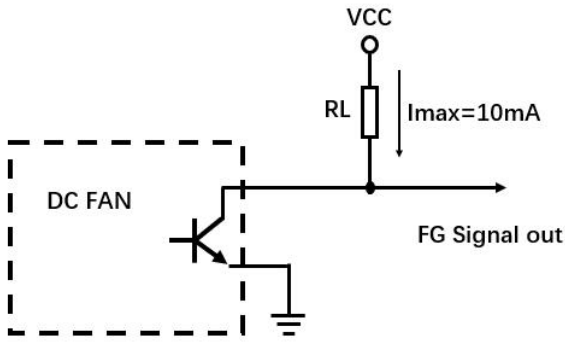

原理图

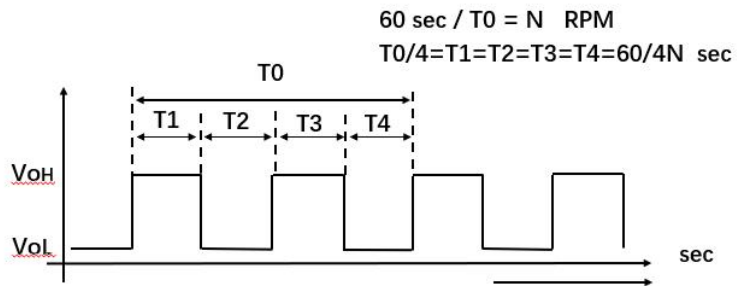

FG信号波形

例：1 秒钟中内检测到高电平的个数除以 2 乘以 60 得到每分钟的转速。 $N/2 * 60$

10. 脉冲占空比调速 (PWM -Curve Graph)

- (1) 三极管“导通”状态/Transistor at “ON” position
 - 集电极电流/Collector Current ----- $I_c=10\text{mA max}$
 - 饱和导通电压/Saturation Voultage ----- $V_{OL}=1\text{V max}$
- (2) 三极管“截止”状态/Transistor at “OFF” position
 - 开路电压/Release Voultage ----- $V_{OH} \leq V_{cc}$
- (3) PWM 数字信号调速/Digital PWM speed control position
 - PWM 输入高电平/PWM Input Voltage High ----- $V_{IH} = 5.5\text{V max}$
 - PWM 输入低电平/PWM Input Voltage Low ----- $V_{IL} \leq 0.6\text{V max}$
 - PWM 脉冲频率/PWM Input Frequency ----- $F_{pwm}:21\text{KHz} - 28\text{KHz}$

CUSTOMER'S CIRCUIT

FAN

CUSTOMER'S CIRCUIT

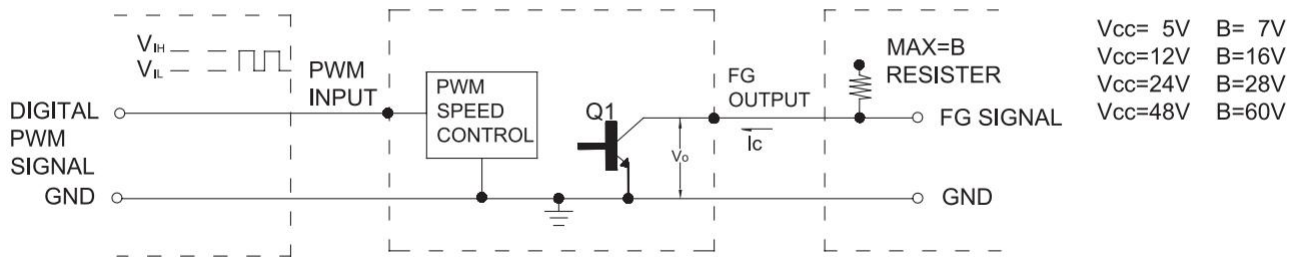

ROTATION

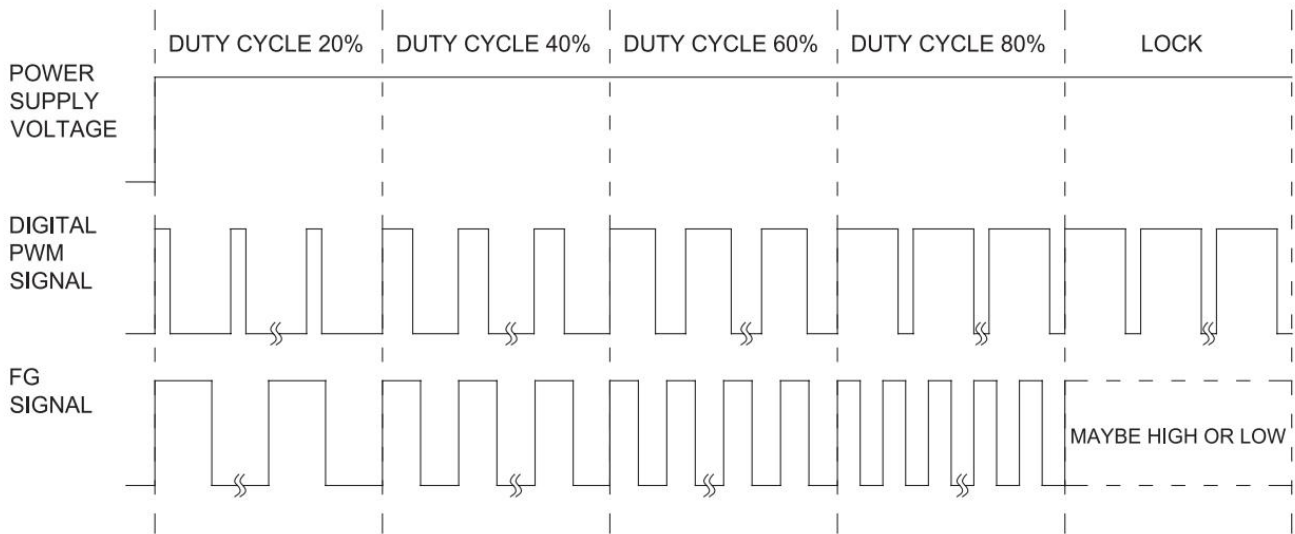

11. PQ 曲线图 (PQ -Curve)

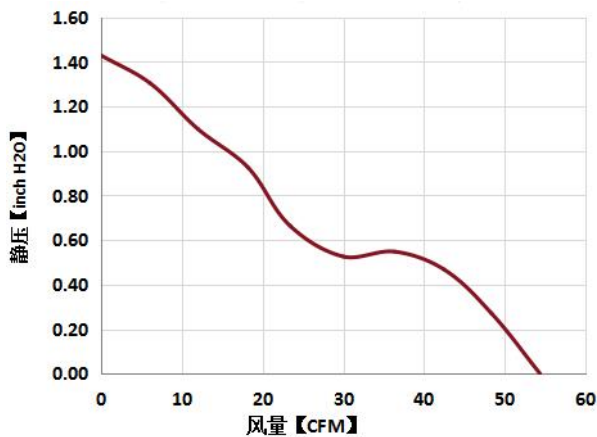

12. 注意事项 (Note)

- a. 我们提供的产品应在规格书指定的条件内使用，如果您的应用超出规格极限，我们对此不保证产品质量。Our products should be used within the specification appointed condition, so we will not guarantee this product quality if your application exceeds the limitations outlined in this specification.
- b. 除非事先通知我们所需求参数，否则出货产品与此份规格书一致，未在此份规格书中指定的参数与贵公司终承认的样品相同。Product will be shipped in accordance with this specification unless we has been previously notified of parameters requiring exception, if parameters which are not specified in this.
- c. 不适当的按装可能产生刺耳的共振，振动和噪音，安装时，请不要在安装点用力过度或用力不均以免造成振动或噪音，在安装点装置减振器，可有效降低噪音及振动。Improper mounting may cause harsh resonance, vibration and noise. Please mount this fan motor properly without applying excessive or uneven force at the mounting points to avoid vibration and noise. Dampers at mounting points can reduce noise and vibrations greatly.
- d. 建议安装风扇保护罩，以免对人员造成意外伤害。Please use fan guards to avoid personal accidental injuries.
- e. 除非 IP 等级中有特殊说明，否则该风扇只能在正常环境下操作。Unless this fan motor is specified for use in abnormal environments designated by IP rating level, this fan is designed to operate under normal environmental conditions.
- f. 请避免将 M-FAN 系列产品接触有毒物质 如:(有机物氰/福尔马林/苯酚等). 以及在腐蚀性气体环境中使用 如:(硫化氢/二氧化硫/二氧化氮等)。Please avoid operating M-FAN' s products in poisonous materinal (organic, cyanogens formal
- g. 当风扇在灰尘环境中使用时，请在风扇进风口处安装过滤装置以延长风扇使用寿命。Please use filters to clean the air-intake in very dusty air environments for ectended fan life.
- h. 在保证产品性能及寿命不变，或者得以提升的条件下。除非事先约定，我们保留使用同等规格多种来源零件的权力，原材料和结构的变更不做预先通知。Unless prior agreement, We reserve the right to use compinents with equivalent specifications from multiple sources, so material and construction are subject to change without advance notice.
- i. 请确保风扇在规定的温湿度储存环境中，如果风扇存储 6 个月以上，我们建议客户测试风扇功能后再使用。Always ensure that fans are stored according to the storage temperatures specified. Do not store in a high humidity environment. If the fans are stored for more than 6 months, we recommend functional testing before using.
- j. 确定在连接和断开连接器之前关掉电源，避免产生电子零件短路。Make sure to turn off the power before connection or disconnecting the connectors. This may ceuse short of electronic parts.