

规格承认书

APPROVAL SHEET

客户名称/ Customer _____

客户料号/ USER P/N _____

品名/DESCRIPTION DC 风扇

产品型号/MODEL No. JC8025B12UC3

产品编号/NOT NUMBER. JC8025B12UC3-24101905

制做日期/ISSUE DATE 2025.01.17

制表 DRAWN	检查 CHECKED	审核 APPROVED	版本 REVISION
刘林艳	孙泽程	刘其浩	A1.0

客户承认/ CUSTOMER APPROVAL

深圳市健策电子有限公司

SHENZHEN JENTECH ELECTRONIC CO., LTD

深圳市龙华区桂月路 306 号仪表世界工业区 6 栋 4 楼

TEL: 0755-23706799 FAT: 0755-23707879

www.jentech.cn

1. 版本记录 (Revised Record)

序号 No.	版本 REV	修改描述 Revision Description	日期 Date	备注 Note
1	A1.0	初版	20250117	

2. 一般规格 (General Specification)

(AT Ta=25°C)

项目 Item		规格/条件 Specification/Condition		
1	型号 Model No.	JC8025B12UC3		
2	外型尺寸 Outline. Dimension	80*80*25mm		
3	工作电压 Operating Voltage	DC8~13.2V		
4	额定电压 Rated voltage	DC12V		
5	额定电流 Rated current (IN FREE AIR)	0.65A (MAX:0.72A)	a. 额定电压 Rated .voltage b.25°C 65% RH c.After testing for 5 minutes	
6	标签电流 Current on label	0.65A		
7	消耗功率 Power consumption (IN FREE AIR)	7.8W (MAX:8.64W)		
8	转速 Speed (IN FREE AIR)	7800RPM ±10%		
9	风量 Airflow AT ZERO STATIC PRESSURE	79.3 (MIN:71.37)	CFM	a. 额定电压 Rated .voltage b. AMCA 标准 Standard C. 额定电流 Rated current
		2.25 (MIN:2.02)	m³/min	
	静压 Air .Static Pressure AT ZERO AIRFLOW	0.744 (MIN:0.603)	inch-H ₂ O	
		185.26 (MIN:150.06)	Pa	
10	噪音标准 Noise Level	48.6 (MAX:50.7)dB-A		a. 额定电压 Rated Voltage b. 18dB无响室 18dB Non-Echo Chamber c. 标准 Standard: CNS 8753 / ISO 3744 d. Test Condition :ISO 7779 e. 距离 Distance: 1.0 M
11	期望寿命 Life expectancy	70000 hrs at temp40°C Humidity5% ~ 95%		MTTF Mean Time To Failure Conf Level 90%
12	极数 No.of.Pole	4 极/Poles		
13	运转方向 Rotating Direction	顺时针/Clockwise (从标签面看/From Label side)		

3. 电气规格 (Electrical Specification)

1	锁住保护 Lock Protection	<input checked="" type="checkbox"/>	风扇停转后,风扇会在2至6秒自动尝试启动 After auto power off, circuit attempt to restart in 2 to 6 sec.		
		<input checked="" type="checkbox"/>	额定电压下堵住2~3秒,风扇自动断电,停止运转,降低内部温升 Auto power off after locked at rated voltage for 2~3 sec. Reduce internal temperature rise		
2	极性保护 Polarity Protection	<input checked="" type="checkbox"/>	VCC与GND反接时 不导通 open circuit when Vcc & GND are exchanged		
3	过压保护 Over voltage Protection	<input type="checkbox"/>	无/NO	<input type="checkbox"/>	是/YES
4	过流保护 Over current Protection	<input type="checkbox"/>	无/NO	<input type="checkbox"/>	是/YES
5	RD 信号 Receive delay	<input type="checkbox"/>	无/NO	<input type="checkbox"/>	是/YES
6	FG 信号 First Grade	<input type="checkbox"/>	无/NO	<input checked="" type="checkbox"/>	是/YES
7	恒速功能 fixed constant speed Function	<input type="checkbox"/>	无/NO	<input type="checkbox"/>	是/YES
8	软启动 Soft Starting	<input type="checkbox"/>	无/NO	<input checked="" type="checkbox"/>	是/YES
9	PWM 功能 PWM function	<input type="checkbox"/>	无/NO	<input checked="" type="checkbox"/>	是/YES
10	绝缘阻抗 Insulation Resistance	10MΩ/裸线与外框间测量, 500VDC/min 10MΩ/between unshackled wire and frame at 500VDC/min			
11	绝缘耐压 Dielectric Strength	5Ma Max./导线与外框间测量, 500VAC/min 5Ma Max./Measured between lead wire(+)and frame at 500VAC/min			
12	防水等级 Waterproof level	无/NO		IPXX protection verification is focused on motor and PCB, not for power connector and pin hosing	

4. 主要材料/零件规格 (Main Materials/parts Specification)

1	轴承/Bearing	<input checked="" type="checkbox"/>	双滚珠轴承 (Dual Ball Bearing)	<input type="checkbox"/>	含油轴承 (Sleeve Bearing)	<input type="checkbox"/>	液压轴承 (Hydraulic Bearing)	
2	外框材质/Frame	<input checked="" type="checkbox"/>	PBT of UL94V-0.			<input type="checkbox"/>	Die-cast Aluminum alloy	
3	扇叶材质 /Impeller	<input checked="" type="checkbox"/>	PBT of UL94V-0.			<input type="checkbox"/>	Steel	
4	绝缘套/Bobbin	<input checked="" type="checkbox"/>	PBT of UL94V-0.					
5	导线/Lead Wire	<input checked="" type="checkbox"/>	Red (+)	<input checked="" type="checkbox"/>	Black (-)	<input checked="" type="checkbox"/>	Blue (PWM)	UL1007 24#
		<input checked="" type="checkbox"/>	Yellow (FG)	<input type="checkbox"/>	White (RD)		4 wires 300±10mm	
6	端子/Connector	无/NO						
7	套管/Tube	无/NO						

5. 环境测试 (Environmental Specification)

1	运转温/湿度范围 Operating Temp .Range	温度/Temperature:-20°C ~ +70°C 湿度/Humidity:5% ~ 95%RH
2	保存温/湿度范围 Storage Temperature	温度/Temperature:-40°C ~ +85°C 湿度/Humidity:5% ~ 95%RH

6. 噪音测试 (Noise is measured at rated voltage in anechoic)

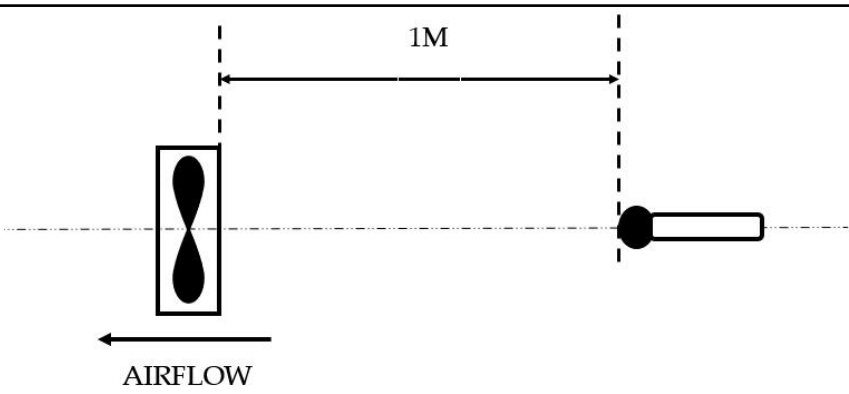

在背景噪音不超过 18dB (A) 的无响室内，将待测风扇通入额定的工作电压，悬掉入空中，将麦克风放于风扇同一平面且离待测风扇进风口一米处进行测试其 B&K 值

Noise is measured rated voltage in free air in anechoic chamber with B&K sound level meter with microphone at a distance of one meter from the fan intake.The background noise is 18Db(A) max.

7. 商标 (Label Marking)



8. 外形尺寸 (Outline Dimension)

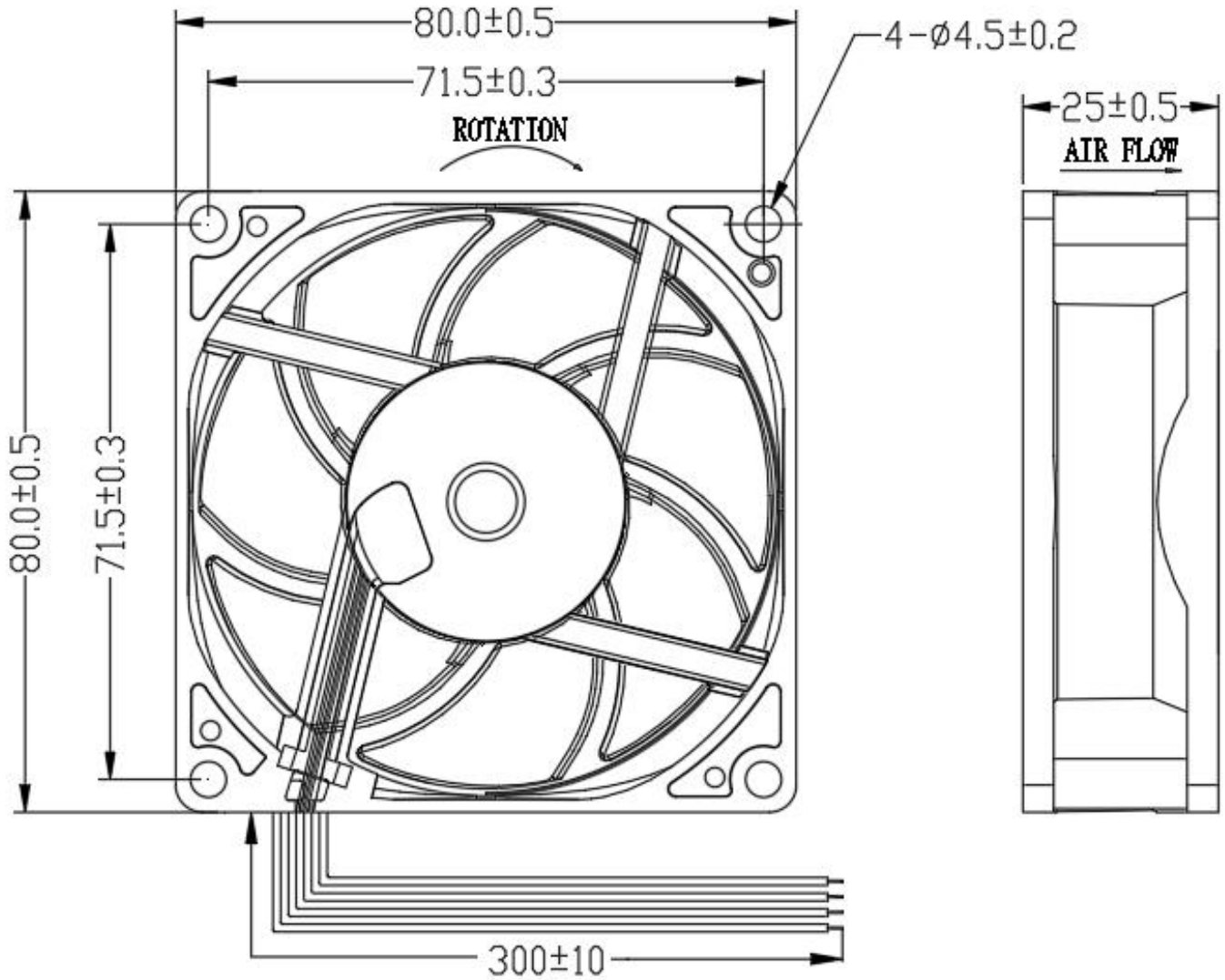

9. 转速检测 (Frequency Generator)

(1) 三极管“导通”状态/Transistor at “ON” position

集电极电流/Collector Current ----- $I_c = 5\text{mA max}$

饱和导通电压/Saturation Voltage ----- $V_{ol} = 1\text{V max}$

(2) 三极管“截止”状态/Transistor at “OFF” position

开路电压/Release Voltage ----- $V_{oh} \leq V_{cc}$

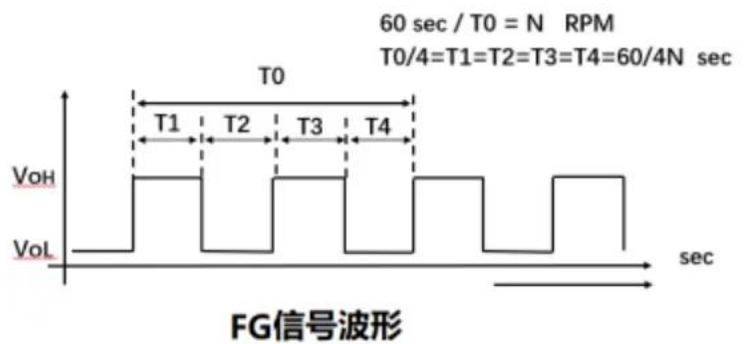
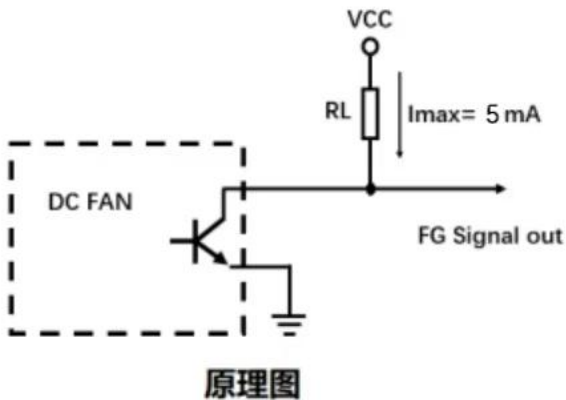

10. 脉冲占空比调速 (PWM -Curve Graph)

- (1) 三极管 “导通” 状态/Transistor at “ON” position
 - 集电极电流/Collector Current ----- $I_c=5mA \text{ max}$
 - 饱和导通电压/Saturation Voltage ----- $V_{OL}=1V \text{ max}$
- (2) 三极管 “截止” 状态/Transistor at “OFF” position
 - 开路电压/Release Voltage ----- $V_{OH} \leq V_{CC}$
- (3) PWM 数字信号调速/Digital PWM speed control position
 - PWM 输入高电平/PWM Input Voltage High ----- $V_{IH} = 4.75-5.25V \text{ max}$
 - PWM 输入低电平/PWM Input Voltage Low ----- $V_{IL} \leq 0.6V \text{ max}$
 - PWM 脉冲频率测试条件/PWM Input Frequency Test conditions ----- $F_{pwm}:AT \ 25KHz$

CUSTOMER'S CIRCUIT

FAN

CUSTOMER'S CIRCUIT

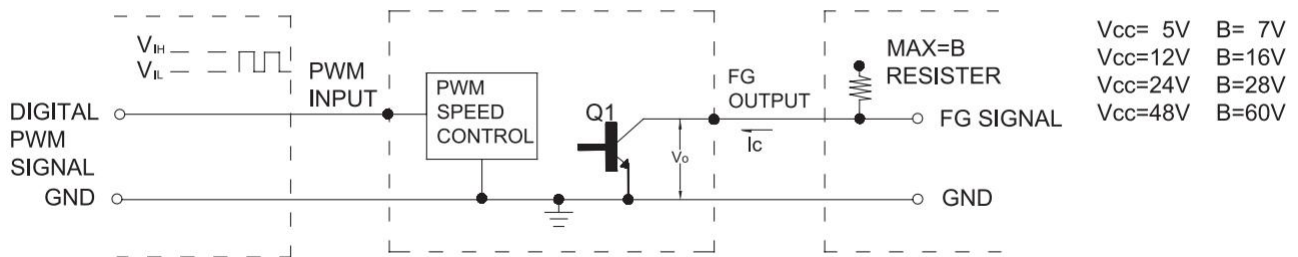

ROTATION

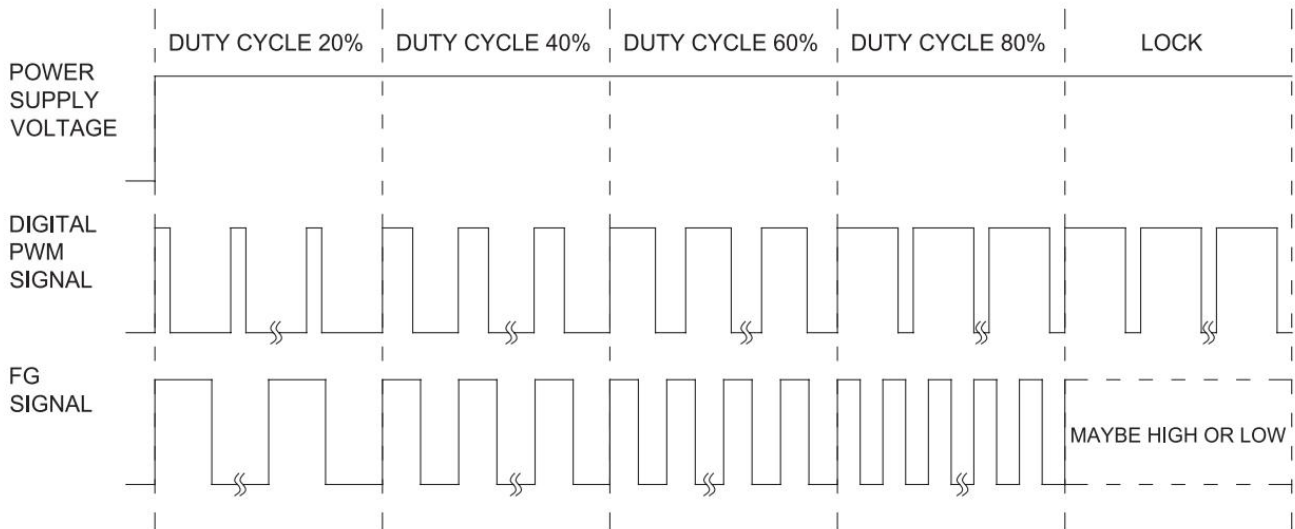

PWM DUTY CYCLE VS.RPM

(AT $T_a=25^\circ C$, IN FREE AIR, PWM: $V_{IH}=5V$, $F_{PWM}=25KHZ$)

DUTY CYCLE	SPEED R.P.M (AVERAGE)	TYPICAL CURRENT(A)
0%	0	0
50%	4500	0.19
100%	7800	0.65

11. PQ 曲线图 (PQ -Curve)

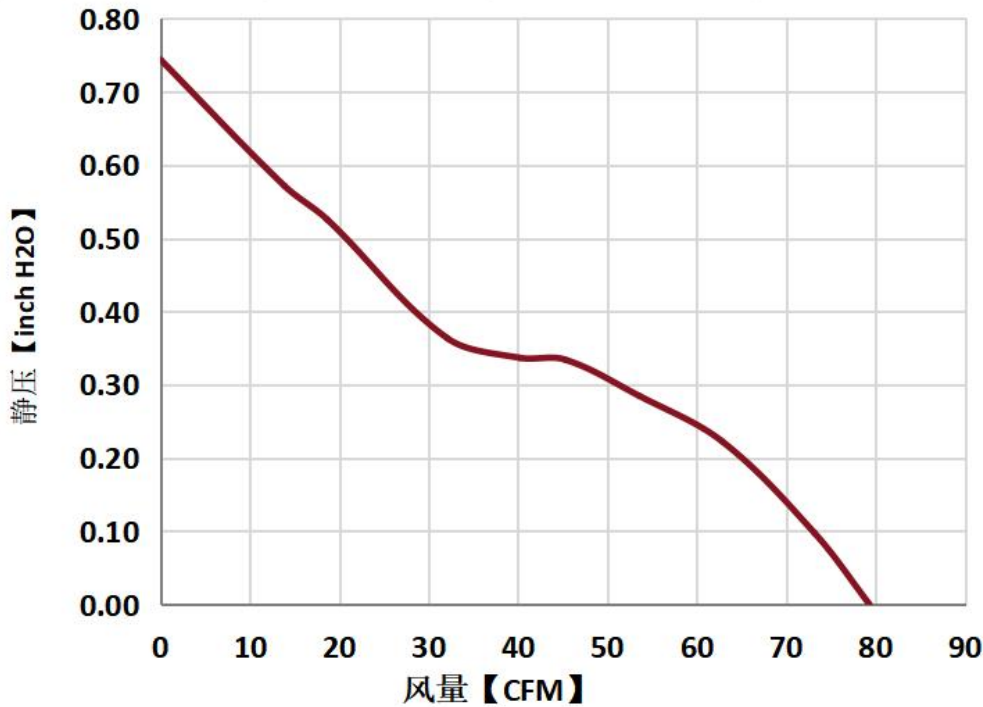

12. 注意事项 (Note)

- 我们提供的产品应在规格书指定的条件内使用，如果您的应用超出规格极限，我们对此不保证产品质量。
Our products should be used within the specification appointed condition, so we will not guarantee this product quality if your application exceeds the limitations outlined in this specification.
- 除非事先通知我们所需求参数，否则出货产品与此份规格书一致，未在此份规格书中指定的参数与贵公司终承认的样品相同。
Product will be shipped in accordance with this specification unless we has been previously notified of parameters requiring exception, if parameters which are not specified in this.
- 不适当的按装可能产生刺耳的共振，振动和噪音，安装时，请不要在安装点用力过度或用力不均以免造成振动或噪音，在安装点装置减振器，可有效降低噪音及振动。
Improper mounting may cause harsh resonance, vibration and noise. Please mount this fan motor properly without applying excessive or uneven force at the mounting points to avoid vibration and noise. Dampers at mounting points can reduce noise and vibrations greatly.
- 建议安装风扇保护罩，以免对人员造成意外伤害。
Please use fan guards to avoid personal accidental injuries.
- 除非 IP 等级中有特殊说明，否则该风扇只能在正常环境下操作。
Unless this fan motor is specified for use in abnormal environments designated by IP rating level, this fan is designed to operate under normal environmental conditions.
- 请避免将 M-FAN 系列产品接触有毒物质 如：(有机物氰/福尔马林/苯酚等). 以及在腐蚀性气体环境中使用 如：(硫化氢/二氧化硫/二氧化氮等)。

Please avoid exposing the M-FAN series products to toxic substances such as (organic cyanide, formaldehyde, phenol, etc.), and using in environments with corrosive gases such as (hydrogen sulfide, sulfur dioxide, nitrogen dioxide, etc.).

- g. 当风扇在灰尘环境中使用时，请在风扇进风口处安装过滤装置以延长风扇使用寿命。

Please use filters to clean the air-intake in very dusty air environments for extended fan life.

- h. 在保证产品性能及寿命不变，或者得以提升的条件下。除非事先约定，我们保留使用同等规格多种来源零件的权力，原材料和结构的变更不做预先通知。

Under the condition of ensuring that product performance and lifespan remain unchanged or can be improved. Unless agreed in advance, we reserve the right to use parts from multiple sources of the same specifications, without prior notice of changes in raw materials and structure.

- i. 请确保风扇在规定的温湿度储存环境中，如果风扇存储 6 个月以上，我们建议客户测试风扇功能后再使用。

Always ensure that fans are stored according to the storage temperatures specified. Do not store in a high humidity environment. If the fans are stored for more than 6 months, we recommend functional testing before using.

- j. 确定在连接和断开连接器之前关掉电源，避免产生电子零件短路。

Make sure to turn off the power before connection or disconnecting the connectors. This may cause short of electronic parts.

13. 风扇安装说明(FAN INSTALLATION INSTRUCTIONS)

- a. 在使用螺栓螺母紧固件的情况下，底盘配合面的平整度应保持在 0.1mm 以下。

In case of using bolt-nut fasteners, the flatness of chassis mating surfaces should be kept below 0.1mm.

- b. 如何固定不同类型的框架

How to fasten the frames of different types

- (a) . 法兰类型：将螺栓和螺母从入口或出口拧在一起。

扭矩不应超过 4.5 kgf-cm [图 (a)]

Flange type:Screw the bolt and nut together from the inlet or outlet.

The torque should not exceed 4.5 kgf-cm [figure(a)]

- (b) . 肋型：将螺栓拧过肋。

扭矩不应超过 7.5kgf-cm [图 (b)]

Rib type:Screw the bolt through the rib.

The torque should not exceed 7.5kgf-cm [figure(b)]

- c. 使用自攻螺钉时，应使用符合 JIS B1122 类型 2 的适当螺钉。推荐的自攻螺钉的尺寸详细信息如表 (a) 所示。每个紧固件孔只能拧紧一次，否则可能会发生打滑。此外，施加在自攻螺钉上的扭矩不得超过表 (a) 中规定的值。

In case of using self-tapping screws, appropriate screws according to JIS B1122 Type 2 should be used. The dimensional details of the self-tapping screws recommended are shown in Table(a). Each fastener hole should only be tightened once or slippage may occur. In addition, the torque to be applied to the self-tapping screws must not exceed the values stated in Table(a).

d. 紧固件头的沉头垫不应干扰框架，否则会有破损的危险 [图 (e)]。建议使用内表面平坦的紧固件头，即无沉头孔。

The countersunk part of fastener head should not interfere with the frame or there would be a risk of breakage [figure(e)]. Fastener head with flat inner surface, i. e. no countersunk, is recommended.

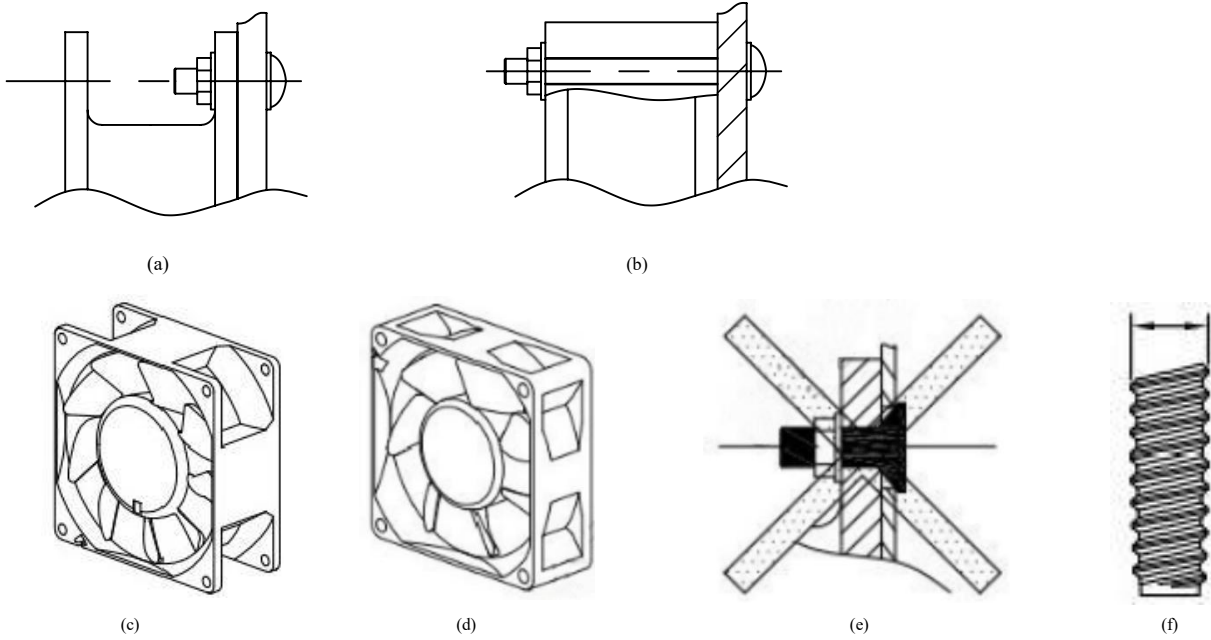

MOUNTING HOLE DIAMETER	SCREW SPEC	MAJOR DIAMETER [Fig. (f)]		**RECOMMENDED MAX. TORQUE (kgf-cm)	
		MAXIMUM	MINIMUM	FLANGE TYPE FRAME	RIB TYP EFRAME
Φ3.5	M4 X1.41	4.0	3.85	4.5	7.5
*Φ4.3	M4.8 X1.59	4.8	4.65	5.5	7.5
Φ4.5	M5 X1.59	5.0	4.85	5.5	7.5

*Non JIS B1122spec.

**A lower torque than the recommended value should be used if slippage is observe.

*非 JIS B1122 规格

**如果发现滑移，应使用低于重新估算值的扭矩。

TABLE (a)