

客 户 :

Customer

客 户 料 号 :

Customer P/N

物 料 名 称 : 一体成型电感

Item Name

瑞 申 型 号 : RS1770系列

Ruishen P/N

承 认 书 编 号 : S2310101

Spec No.

版 本 号 : A0

Version No.

制 造 商 Manufacture	
拟 制 Prepared	刘昊
审 核 Checked	王文俊
批 准 Approved	张子怡
日 期 Date	2023/10/10

客 户 承 认 Approved by Customer	
批 准 Approved	
日 期 Date	

备 注:

Remark

1. 在使用产品前, 用户必须确认此产品是否适用于自身设计, 瑞申仅保证产品符合此份承认书的规格。
Before use, customer should confirm whether this product is suitable for their design, Ruishen only ensure products meet this specification.
2. 本承认书的数据更改, 必须经双方确认, 任何一方单独修改无效。
This specification data change must be confirmed by both parties, any individual modification is invalid.
3. 如客户未回签承认书即下订单, 则视为承认此份承认书。
If customer placed orders without signing back this specification, it is regarded as recognition.



1 型号定义

Type No. definition

RS	1770	-	100	M	S
①	②		③	④	⑤

- ① 产品代码 Product Code 一体成型电感
- ② 产品尺寸 Dimension 17X18X7.0mm
- ③ 电感值 Inductance 例Example: R47=0.47uH 1R0=1.0uH 220=22uH
- ④ 公差范围 Tolerance J = ±5% K = ±10% L = ±10% M = ±20% N = ±30%
- ⑤ 表面颜色 Over coating S:本色喷码印字Iron grey and marking.

2 外形尺寸(mm)

Appearance and dimensions

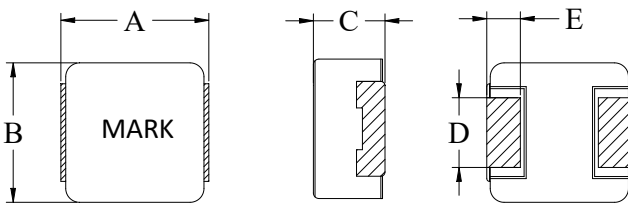

A	B	C	D	E
18.25±0.5	17.0± 0.5	7.0MAX	12.0±0.5	3.2±0.5

3 原理图

Schematic

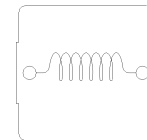

4 印字标识

Marking



※ MARK:感值

5 参考基板尺寸(mm)

Reference PCB pattern

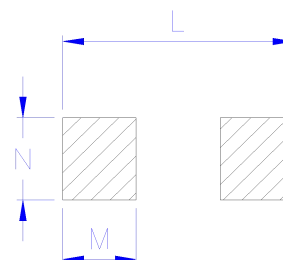

L	19.7	Ref.
M	4	Ref.
N	13	Ref.



6 电气特性

Electrical characteristics

型号 Type No.	电感值 Inductance μH	直流电阻 DC Resistance $\text{m}\Omega$	温升电流 Heat Rating Current A	饱和电流 Saturation Current A
	$\pm 20\%$	Max.	Max.	Max.
RS1770-R68MS	0.68	2.0	45.0	55.0
RS1770-1R5MS	1.5	2.5	40.0	45.0
RS1770-2R2MS	2.2	3.0	34.0	37.0
RS1770-3R3MS	3.3	3.5	26.0	30.0
RS1770-4R7MS	4.7	5.0	22.0	27.0
RS1770-6R8MS	6.8	7.0	20.0	26.0
RS1770-100MS	10	12.0	17.0	23.0
RS1770-150MS	15	16.5	11.0	16.0
RS1770-220MS	22	24.0	10.0	15.0
RS1770-330MS	33	35.0	9.0	12.0
RS1770-470MS	47	50.0	8.0	9.5
RS1770-680MS	68	87.0	6.0	8.0
RS1770-101MS	100	122.0	5.0	7.0

※1 电感值测试条件为100KHZ 0.1V.

Inductance is tested at 100KHZ 0.1V.

※2 温升电流：使产品温度上升到 $\Delta T 40^{\circ}\text{C}$ 时所加载的直流电流值($T_a=25^{\circ}\text{C}$)。

Heat rating current: The value of DC current when product temperature rise is $\Delta T 40^{\circ}\text{C}$ ($T_a=25^{\circ}\text{C}$).

※3 饱和电流：电感值下降其初始值的30%时所加载的直流电流值。

Saturation current: The value of DC current when the inductance decreases 30% of its initial value.

※4 特别提示:线路设计,组件布局,使用频率,散热系统等均会影响产品温度,请务必验证产品实际发热状况。

Special remind: Circuit design, component placement, frequency, cooling system and etc. all will affect the product temperature. Please verify the actual product temperature in the final application.

※5 所有数据基于环境温度 25°C 条件下测试。

All data is tested on 25°C ambient temperature.

※6 工作温度范围： $-40^{\circ}\text{C} \sim +125^{\circ}\text{C}$ （包含产品发热）

Operating temperature range : $-40^{\circ}\text{C} \sim +125^{\circ}\text{C}$ (Including self-temperature rise)



7 包装规格 (Dimensions in mm) Packaging specification

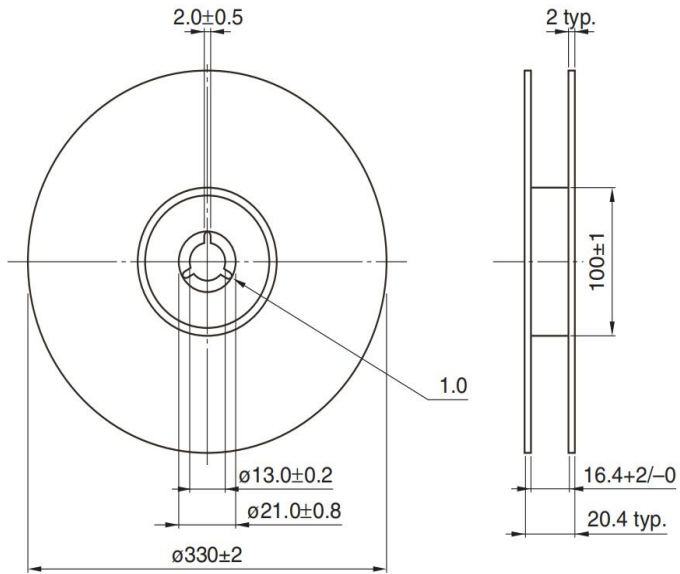

300 pcs/reel



8 回流焊接规范

Reflow soldering specification

8.1 SMT回流焊温度曲线

Reflow profile for SMT components

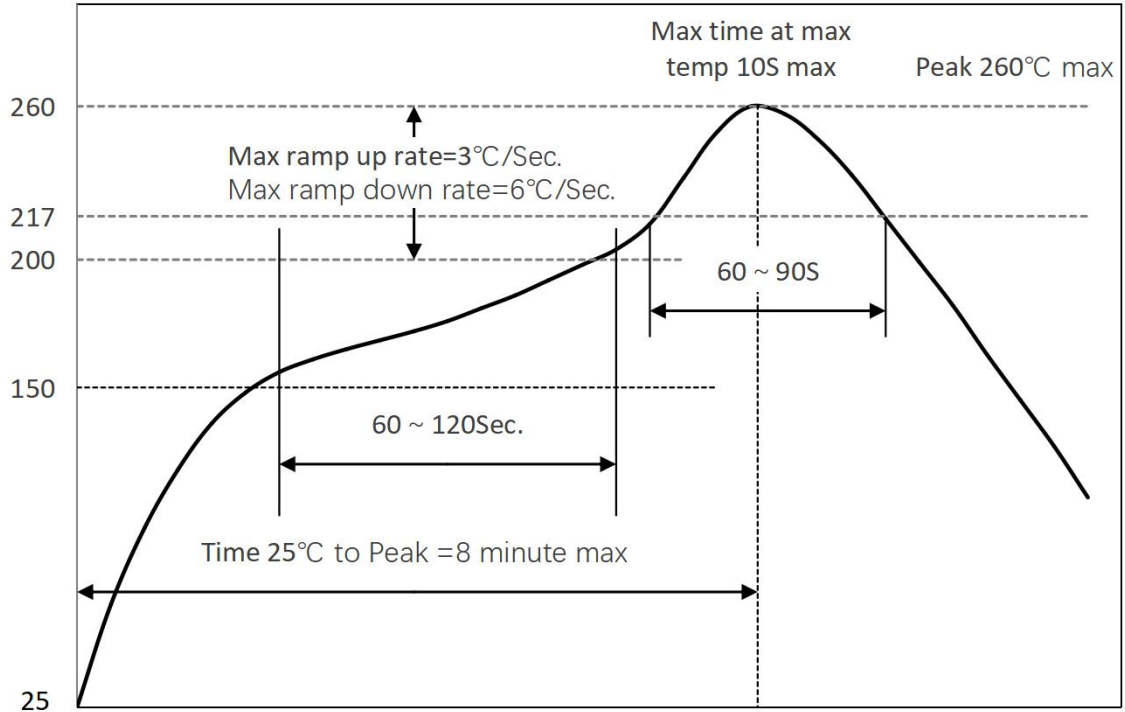

8.2 封装体积与峰值温度(TP)关系分类

Classification of peak package body temperature (TP)

无铅装配 PB-Free Assembly	封装厚度 Package Thickness	封装体积 Package Volume		
		<350 mm ³	350~2000 mm ³	>2000 mm ³
	<1.6mm	260°C	260°C	260°C
	1.6~2.5mm	260°C	250°C	245°C
	≥2.5mm	250°C	245°C	245°C

※回流焊参照标准IPC/JEDEC J-STD-020D。

Reflow is referred to standard IPC/JEDEC J-STD-020D.

8.3 烙铁焊接：温度350°C± 10°C，焊接时间3S以内。

Iron soldering: temperature 350°C± 10°C, dwell time shall be less than 3S.

