

規格承認書

PECIFICATION FOR APPROVAL

客戶

CUSTOMER :

項目

ITEM : 塑壳内磁侧音喇叭

型號

TYPE : GSPK3520037RBOX-8R1W-L100 线长端子可订制

描述

DESCRIPTION : L35*W20*H3.7mm 焊线 L100mm 8ohm 1W S.P.L: 82dB+/- 3dB

客戶料號

CUSTOMER NO. :

規格書號

SPECIFICATION NO.:

版本

EDITION NO. : V1.1

日期

DATE : 20

客戶承認

CUSTOMER CONFIRM AND SIGN

檢查 TESTED BY	審核 CHECKED BY	承認 APPROVED BY

東莞市贏海電子有限公司

DONGUAN INGHAIELECTRONICS CO.,LTD

製作 ISSUED BY	審查 CHECKED BY	確認 APPROVED BY
周明	刘承成	

地址：廣東省東莞市長安鎮新崗路華茂大廈 15 樓

電話 / TEL: 18028992498

網址: [HTTP://WWW.INGHAI.COM](http://www.inghai.com)

Model No.	GSPK3520037RBOX-8R1W-L100	Date	2023-09-06	Page No.	1 / 6
產品規格內容 (SPECIFICATION)					
1.使用範圍 (Scope)					
<p>此份規格書是針對多媒體產品內，所使用的微型揚聲器單體所提出的報告。</p> <p>This specification covers our product of miniature speaker unit for multimedia product.</p>					
2.标准测试条件(Test condition)					
<p>一般规格试验状态（特殊要求除外）：常温 5~35℃，常湿 45%~85%，气压 860~1060hPa。</p> <p>判定上有疑问时，试验状态为：温度 20±2℃，相对湿度 60%~70%，气压 860~1060 hPa。</p> <p>The test conditions unless otherwise specified should be normal temperature 5 to 35 ℃,Normal humidity 45 to 85% and normal atmospheric pressure 860 to 1060 hPa,However,if there arises a doubt in judgment,the test conditions shall beas follows:</p>					
<p>Temperature 20±2℃</p> <p>Humidity 60%~70%</p> <p>Atmosphere 860~1060 hPa</p>					
3.電聲特性 (ELECTRO-ACOUSTIC CHARACTERISTICS)					
<p>3.1 額定阻抗(Rated Impedance):</p> <p>8.0Ω ± 15% (AT 1.6K Hz ,1.0 Vrms)</p>					
<p>3.2 額定輸入功率(Rated Input Power)</p> <p>1.0 Watt (At 2.83 Vrms white noise 24 Hours)</p>					
<p>3.3 最大輸入功率(Max. Input Power)</p> <p>1.2Watt</p>					
<p>3.4 最低共振頻率(Resonant Frequency)</p> <p>900 Hz ± 20%</p>					
<p>3.5 輸出音壓(Output S.P.L)</p> <p>82 ± 3dB (1.0 Watt , 0.1 Meter. Average at 1.5K,2.0K,2.5K,3.0K Hz)</p>					
<p>3.6 實效頻率範圍(Frequency Range)</p> <p>Fo ~ 20KHz (By Output S.P.L. -10dB)</p>					
<p>3.7 失真率(Distortion)</p> <p>Less than 5% (At 1.6KHz , 2.83 Vrms)</p>					
<p>3.8 工作溫度(Operating Temperature)</p> <p>-25℃ ~ +50℃</p>					
<p>3.9 儲存溫度(Storage temperature)</p> <p>-25℃ ~ +55℃</p>					
制 定	审 核	核 准	文 件 编 号		
Xuan xing xian					

產品規格內容 (SPECIFICATION)

Model No.	GSPK3520037RBOX-8R1W-L100	Date	2023-09-06	Page No.	2 / 6
------------------	---------------------------	-------------	------------	-----------------	-------

4. 可靠性測試 (Reliability Test)

4.1 高低溫差循環測試(Temperature Cycling Test)

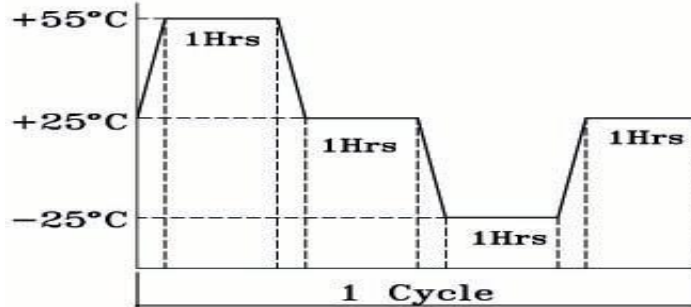

A	Low Temperature (-25°C±3°C)
B	High Temperature (+55°C±3°C)
C	Number of Cycle (3 Cycles)
D	Duration of Exposure 1 Hours, at Each Temperature Extremes
E	Duration of Recovery 1 Hours

4.2 抗濕度試驗(Humidity Test)

A	相對濕度(Relative Humidity)	90-95% at + 40°C ± 3°C
B	測試時間(Durations)	96 Hours
C	恢覆時間(Durations of recovery)	6 Hours

4.3 連續負載測試(Load Test)

White Noise Without Weighted Filter 2.83 Volts.(RMS) 24 Hrs.

4.4 跌落試驗(Drop Test)

75 cm Free Falling On Concrete Floor, 10 Times.

4.5 異常音測試(Buzzes & Rattles)

Sine wave between at 2.83 Vrms / 50~5000Hz

4.6 極性測試(Polarity test)

Diaphragm Shall Move Forward When Apply a Positive DC. Current to the “+” or “Marked” Terminal.

產品規格內容 (SPECIFICATION)

Model No.	GSPK3520037RBOX-8R1W-L100	Date	2023-09-06	Page No.	3 / 6
-----------	---------------------------	------	------------	----------	-------

5.測量方式 (Measurement Method)

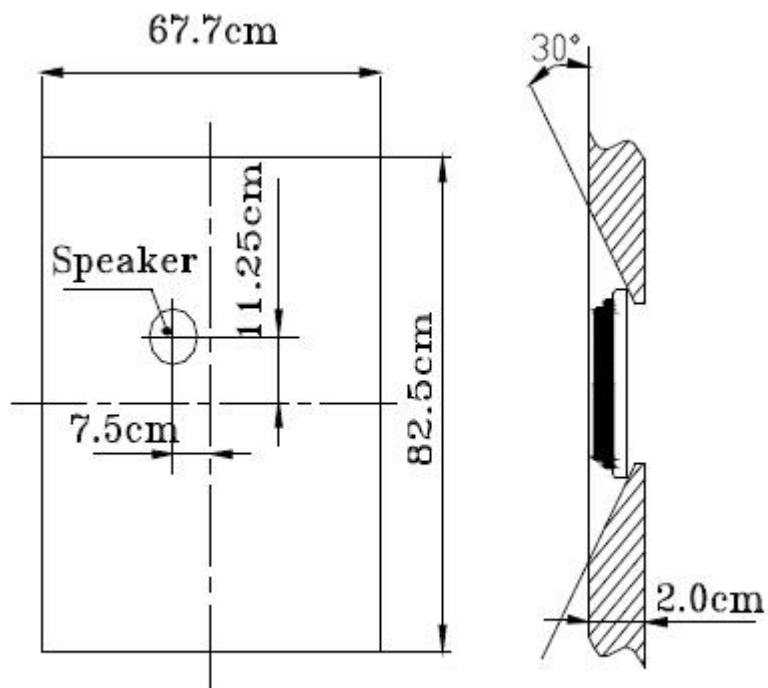
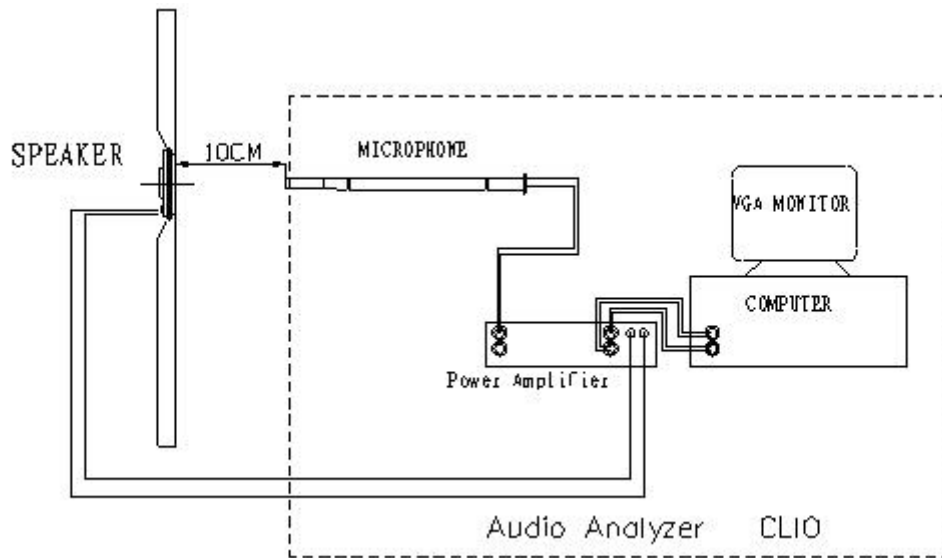

產品規格內容 (SPECIFICATION)

Model No.	GSPK3520037RBOX-8R1W-L100	Date	2023-09-06	Page No.	4/6
-----------	---------------------------	------	------------	----------	-----

6. 頻率響應曲線圖(Frequency Response Curve)

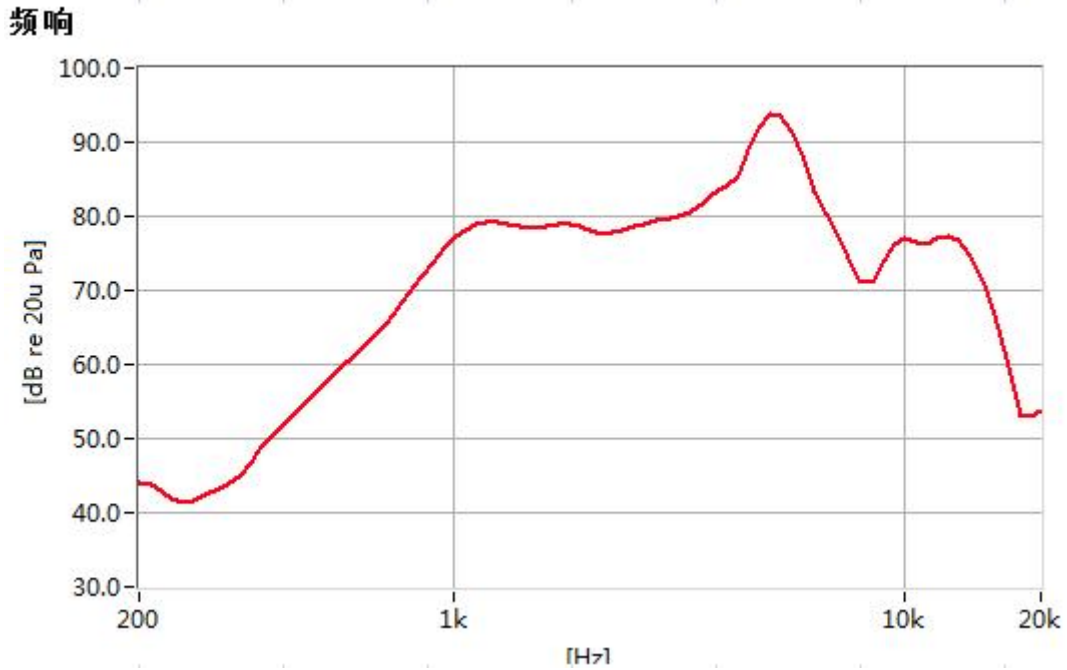

7. 阻抗曲線圖(Impedance Curve)

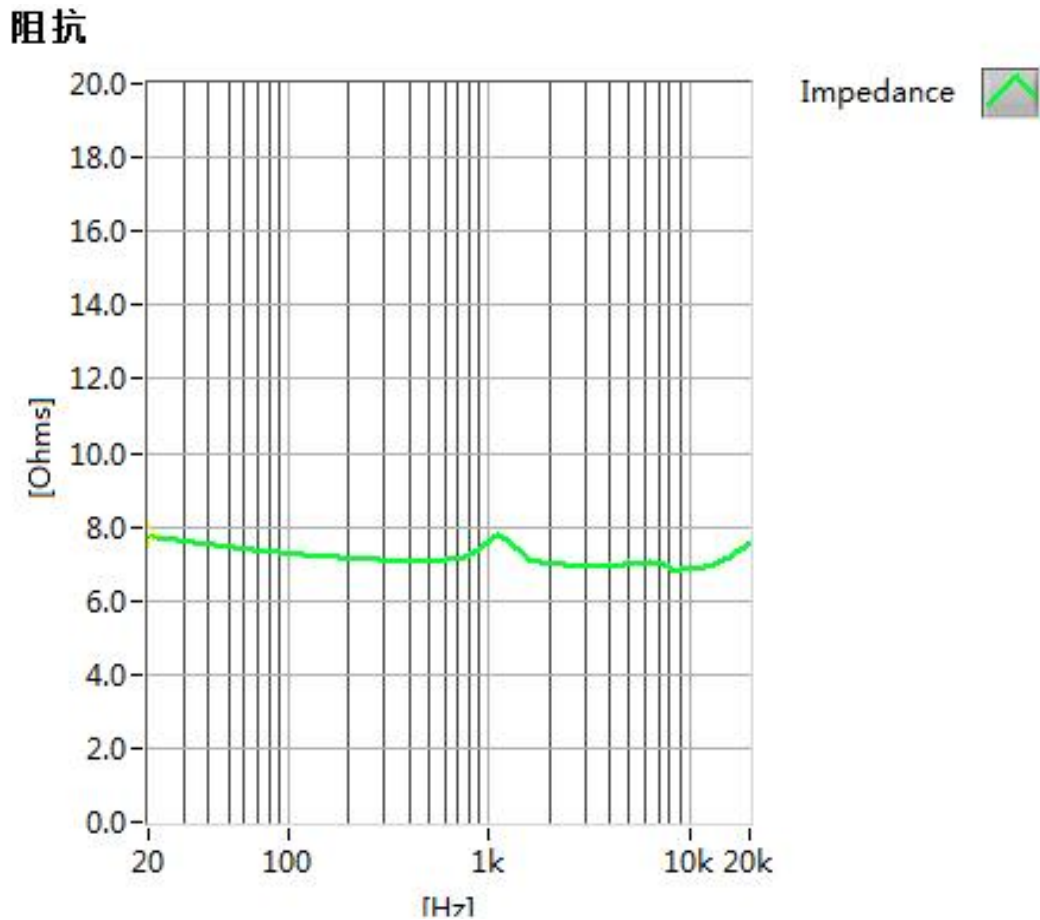

產品規格內容 (SPECIFICATION)

Model No.	GSPK3520037RBOX-8R1W-L100	Date	2023-09-06	Page No.	5 / 6
-----------	---------------------------	------	------------	----------	-------

8. 喇叭外觀描述

(Unit:mm tolerance:±0.3) 立创出货安排焊线 L100mm 线长端子可找原厂订制

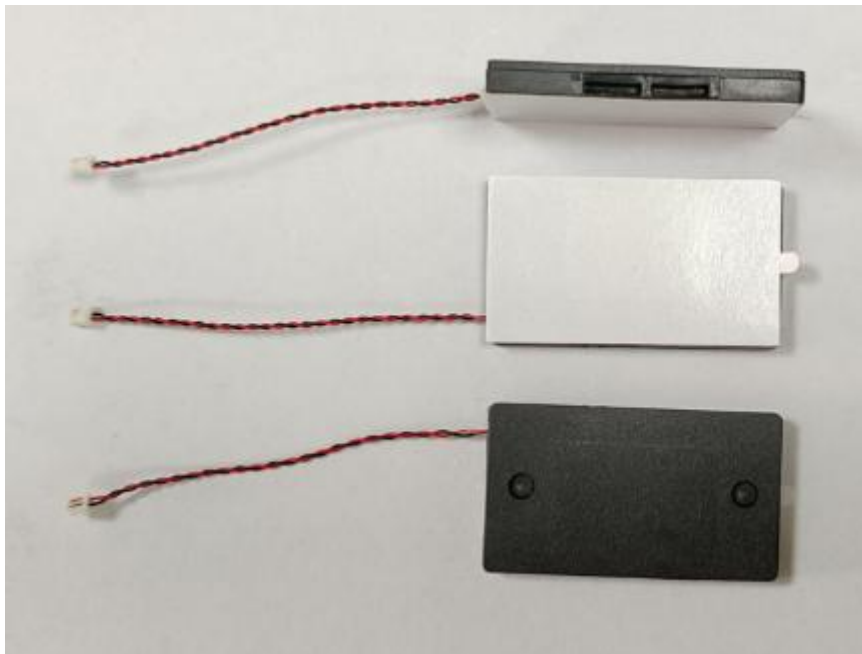
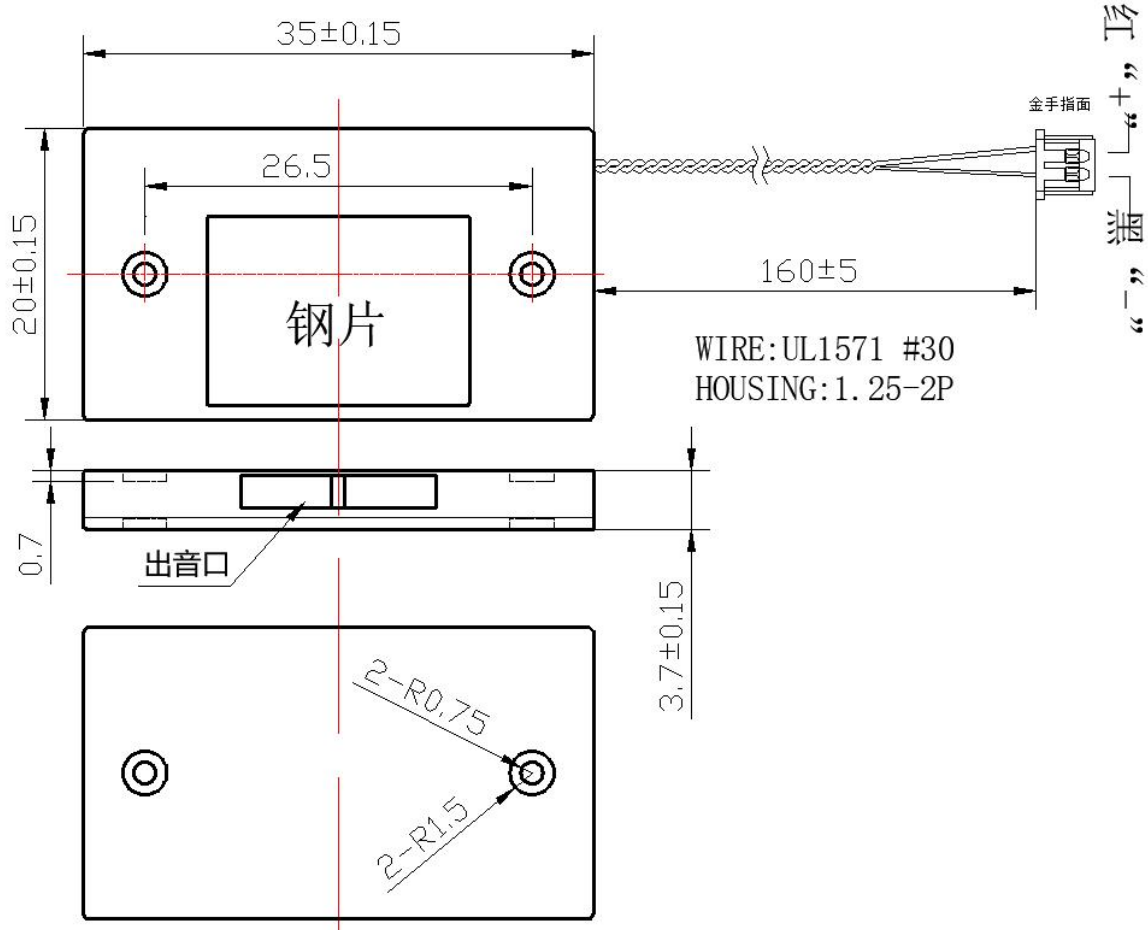

產品規格內容 (SPECIFICATION)

Model No.	GSPK3520037RBOX-8R1W-L100	Date	2023-09-06	Page No.	6/6
------------------	---------------------------	-------------	------------	-----------------	-----

10. 包裝示意圖(Packing Standard):

(Unit:cm tolerance:±3)

按客户要求包装

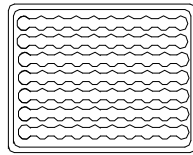

PVC
Q`TY=70PCS

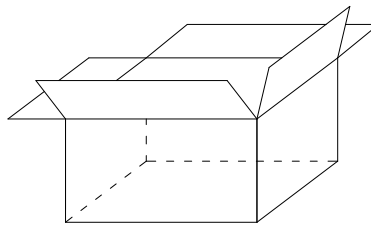
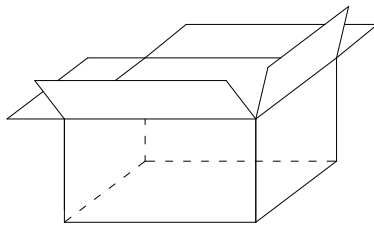
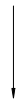
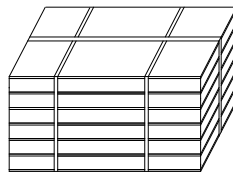
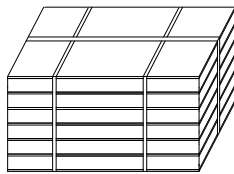

INNER BOX
Q`TY:100*10=1000PCS

INNER BOX
Q`TY:100*10=1000PCS

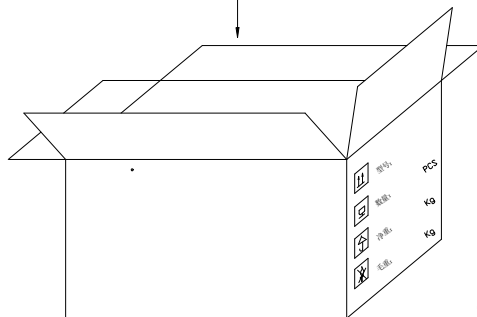
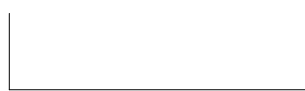

BOX
Q`TY:1000*2=2000PCS